

## 100mA Current、30V Input Voltage、Low Power LDO

### 78LXX

#### General Description

78LXX is three-terminal positive regulators. One of these regulators can deliver up to 100mA of output current. The internal limiting and thermal-shutdown features of the regulator make them essentially immune to overload. When used as are placement for a zener diode-resistor Combination, an effective improvement in output impedance can be obtained, together with lower quiescent current.

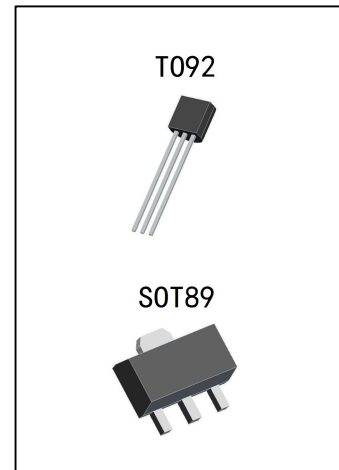

#### Features

- Output Current of 100mA
- Thermal Overload Protection
- Short Circuit Protection
- Output transistor safe area protection
- No external components
- Package: SOT89 and TO92
- Output voltage accuracy: tolerance  $\pm 5\%$

#### Order Information

Part No	Output Voltage	Output Voltage Accuracy
78L05	5.0V	$\pm 5\%$
78L06	6.0V	$\pm 5\%$
78L08	8.0V	$\pm 5\%$
78L09	9.0V	$\pm 5\%$
78L12	12.0V	$\pm 5\%$

Package	Manner of Packing	Devices per bag/reel
TO92	Bag	1000PCS/bag
SOT89	Reel	1000PCS/reel

## Block Diagram and Pin Arrangement Diagram

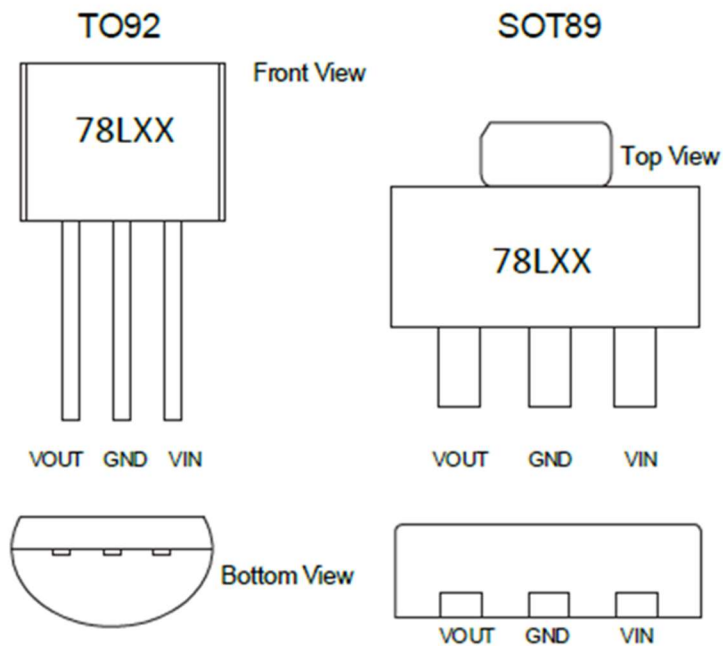
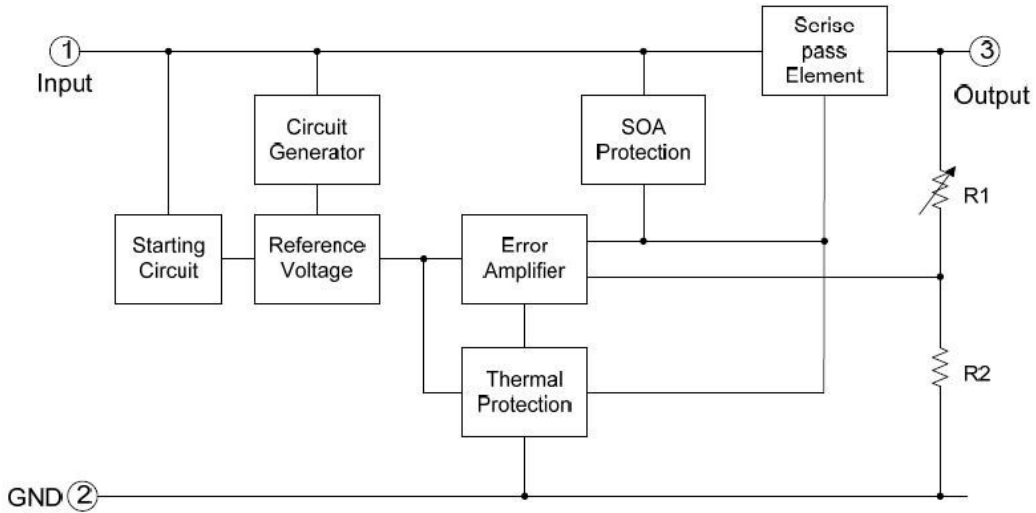

## Pin Assignment

Pin No.	Pin Name	Description
1	VOUT	Output.
2	GND	Ground connection.
3	VIN	Supply Voltage Input.

## Functional Description

78LXX is three-terminal positive regulators. One of these regulators can deliver up to 100mA of output current. The internal limiting and thermal-shutdown features of the regulator make them essentially immune to overload. The output voltage can be 5.0V, 6.0V, 8.0V, 9.0V or 12.0V.

## Absolute Maximum Ratings

Parameter	Symbol	Value	Unit
Supply Voltage Input	V <sub>IN</sub>	30	V
MAX. Output current	I <sub>OUT</sub>	100	mA
MAX. Power SOT-89	P <sub>MAX</sub>	0.5	W
MAX. Power TO-92	P <sub>MAX</sub>	0.625	W
Maximum junction temperature	T <sub>j</sub>	-25~125	°C
Storage Temperature	T <sub>str</sub>	-55~125	°C
Soldering temperature and time	T <sub>st</sub>	+260(Recommended 10S)	°C

Note: The absolute maximum ratings are rated values exceeding which the product could suffer physical damage. These values must therefore not be exceeded under any conditions.

## Electrical Characteristics

$C_{IN}=0.33\mu F, C_O=0.1\mu F, 0 \leq T_j \leq 125^\circ C$ , unless otherwise noted.

Parameter	Symbol	Test Conditions	Min.	Typ.	Max.	Unit
Output Voltage	$V_{OUT}$	$I_O=40mA, V_{IN}=10V$	$0.964 \cdot V_{OUT}$	$V_{OUT}$	$1.036 \cdot V_{OUT}$	V
		$I_O=1mA \sim 40mA$ $V_{IN}=7V \sim 18V$	$0.96 \cdot V_{OUT}$	$V_{OUT}$	$1.04 \cdot V_{OUT}$	V
		$I_O=1mA \sim 10mA$ $V_{IN}=10V$	$0.95 \cdot V_{OUT}$	$V_{OUT}$	$1.05 \cdot V_{OUT}$	V
Line Regulation	LNR	$V_{IN}=7V \sim 18V,$ $I_O=20mA$	-150	-	150	mV
		$V_{IN}=8V \sim 18V,$ $I_O=20mA$	-100	-	100	mV
Load Regulation	LDR	$V_{IN}=10V,$ $I_O=1mA \sim 100mA$	-100	-	100	mV
		$V_{IN}=10V,$ $I_O=1mA \sim 40mA$	-30	-	30	mV
Output noise Voltage	$V_N$	$F=10Hz$ to 100KHz	-	40	-	$\mu V/V_o$
Ripple Rejection	PSRR	$T_j=25^\circ C, f=120Hz,$ $I_O=40mA,$ $V_{IN}=8V \sim 20V$	-	80	-	dB
Quiescent Current	$I_Q$	$V_{IN}=10V,$ $I_{OUT}=40mA$	-	-	5.5	mA
Quiescent Current Change	$\Delta I_Q$	$V_{IN}=8V \sim 18V,$ $I_O=20mA$	-1.5	-	1.5	mA
		$V_{IN}=10V,$ $I_{OUT}=1mA \sim 40mA,$	-0.1	-	0.1	mA

LNR: Line Regulation. The change in output voltage for a change in the input voltage. The measurement is made under conditions of low dissipation or by using pulse techniques such that the average chip temperature is not significantly affected.

LDR: Load Regulation. The change in output voltage for a change in load current at constant chip temperature.

## Typical Performance Characteristics

Output Voltage vs. Input voltage

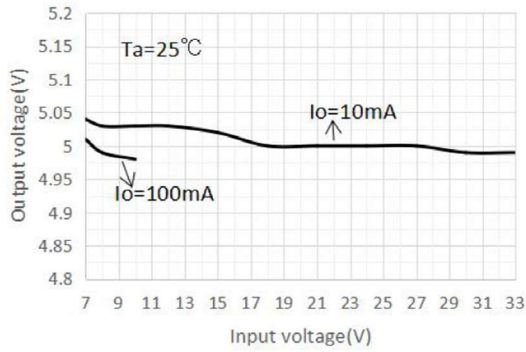

Output Voltage vs. Load

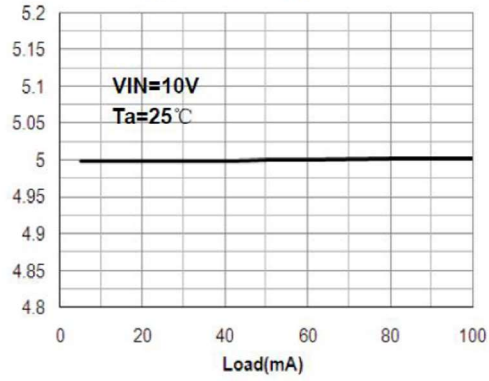

Output voltage vs. Temperature

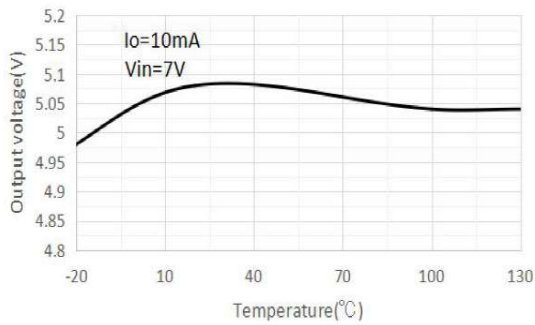

Dropout Voltage vs. Load

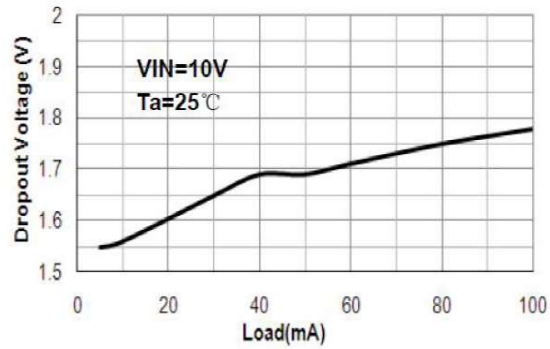

Quiescent current vs. Input voltage

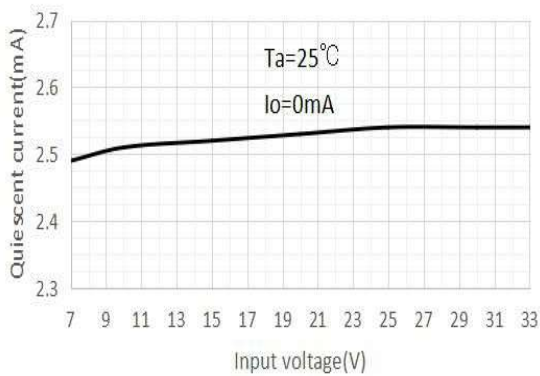

Quiescent Current vs. Load

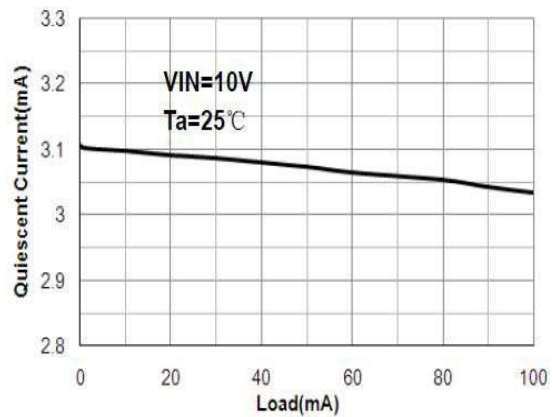

## Application Circuits

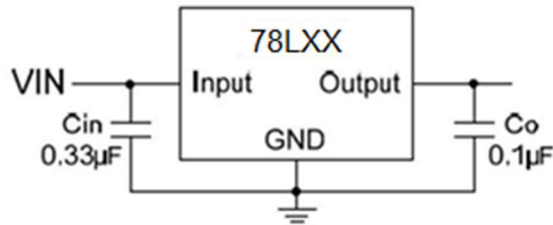

Fig.1 Fixed Output Regulator

A common ground is required between the input and the output voltages. The input voltage must remain typically 2.0V above the output voltage even during the low point on the input ripple voltage.

- $C_{in}$  is required if regulator is located an appreciable distance from power supply filter.
- $C_o$  is not needed for stability; however, it does improve transient response.

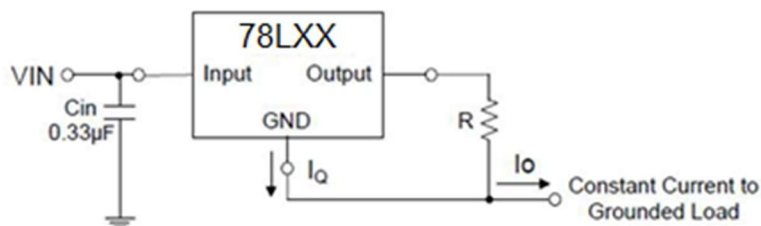

Fig.2 Constant Current Regulator

The 78LXX regulator can also be used as a current source when connected as Fig.2. In order to minimize dissipation the 78LXX is chosen in this application. Resistor R determines the current as follows:

$$I_o = \frac{5V}{R} + I_q$$

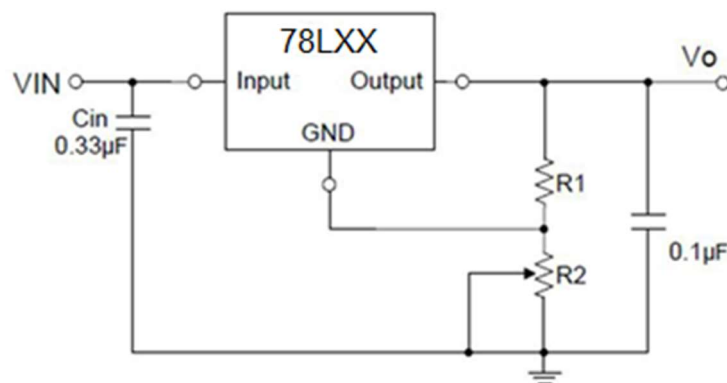

Fig.3 Adjustable Output Regulator

$$V_o = 5V + (5V/R_1 + I_q) \cdot R_2$$

$$5V/R_1 > 3 \cdot I_q$$

## Operation Description

78LXX is designed with Thermal Overload Protection that shuts down the circuit when subjected to an excessive power overload condition, Internal Short Circuit Protection that limits the maximum current the circuit will pass, and Output Transistor Safe-Area Compensation that reduces the output short circuit current as the voltage across the pass transistor is increased.

In many low current applications, compensation capacitors are not required. However, it is recommended that the regulator input be bypassed with a capacitor if the regulator is connected to the power supply filter with long wire lengths, or if the output load capacitance is large. An input bypass capacitor should be selected to provide good high frequency characteristics to insure stable operation under all load conditions. A 0.33  $\mu$  For larger tantalum, mylar, or other capacitor having low internal impedance at high frequencies should be chosen. The bypass capacitor should be mounted with the shortest possible leads directly across the regulator's input terminals. Normally good construction techniques should be used to minimize ground loops and lead resistance drops since the regulator has no external sense lead.

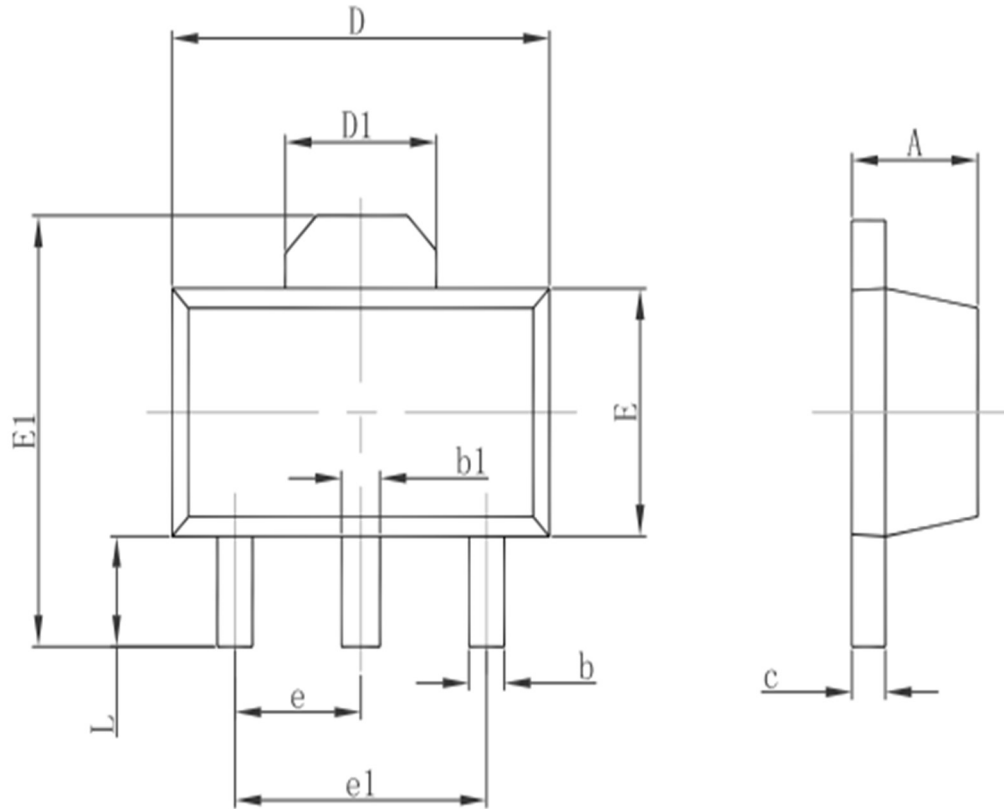
**Package Information (SOT89)**

Symbol	Dimensions In Millimeters		Dimensions In Inches	
	Min.	Max.	Min.	Max.
<b>A</b>	1.400	1.600	0.055	0.063
<b>b</b>	0.320	0.520	0.013	0.020
<b>b1</b>	0.400	0.580	0.016	0.023
<b>c</b>	0.350	0.440	0.014	0.017
<b>D</b>	4.400	4.600	0.173	0.181
<b>D1</b>	1.550REF.		0.061REF.	
<b>E</b>	2.300	2.600	0.091	0.102
<b>E1</b>	3.940	4.250	0.155	0.167
<b>e</b>	1.500TYP.		0.060TYP.	
<b>e1</b>	3.000TYP.		0.118TYP.	
<b>L</b>	0.900	1.200	0.035	0.047

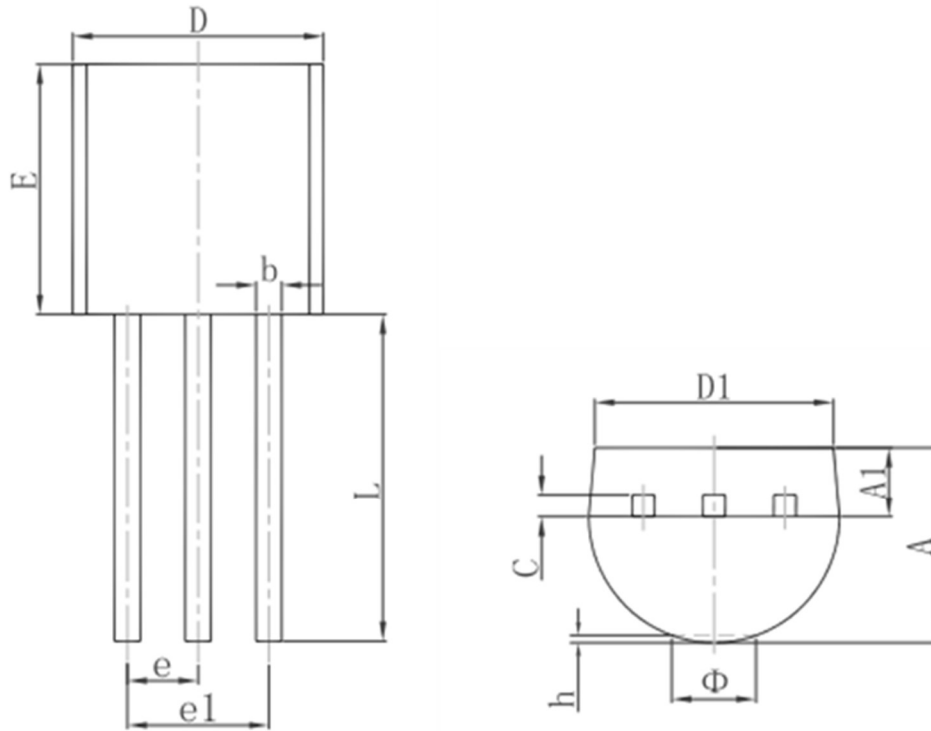

**Package Information (T092)**

Symbol	Dimensions In Millimeters		Dimensions In Inches	
	Min.	Max.	Min.	Max.
<b>A</b>	3.300	3.700	0.130	0.146
<b>A1</b>	1.100	1.400	0.043	0.055
<b>b</b>	0.380	0.550	0.015	0.022
<b>c</b>	0.360	0.510	0.014	0.020
<b>D</b>	4.300	4.700	0.169	0.185
<b>D1</b>	3.430		0.135	
<b>E</b>	4.300	4.700	0.169	0.185
<b>e</b>	1.270TYP.		0.050TYP.	
<b>e1</b>	2.440	2.640	0.096	0.104
<b>L</b>	14.100	14.500	0.555	0.571
<b>Φ</b>		1.600		0.063
<b>h</b>	0.000	0.380	0.000	0.015

## Special Instructions

The company reserves the right of final interpretation of this specification.

## Version Change Description

---

Version: V1.8

Author: Yangyang

Time:

2021.11.9

Modify the record:

1. Re-typesetting the manual and checking some data
-

## X-ON Electronics

Largest Supplier of Electrical and Electronic Components

*Click to view similar products for [Linear Voltage Regulators](#) category:*

*Click to view products by [Siproin](#) manufacturer:*

Other Similar products are found below :

[LV5684PVD-XH](#) [MCDTSA6-2R](#) [L7815ACV-DG](#) [LV56801P-E](#) [UA7805CKC](#) [714954EB](#) [ZMR500QFTA](#) [BA033LBSG2-TR](#)  
[NCV78M05ABDTRKG](#) [LV5680P-E](#) [L79M05T-E](#) [L78LR05D-MA-E](#) [NCV317MBTG](#) [NTE7227](#) [MP2018GZD-33-P](#) [MP2018GZD-5-P](#)  
[LV5680NPVC-XH](#) [ZTS6538SE](#) [UA78L09CLP](#) [UA78L09CLPR](#) [CAT6221-PPTD-GT3](#) [MC78M09CDTRK](#) [NCV51190MNTAG](#)  
[BL1118CS8TR1833](#) [BL8077CKETR33](#) [BL9153-33CC3TR](#) [BL9161G-28BADRN](#) [BRCO7530MMC](#) [CJ7815B-TFN-ARG](#) [LM317C](#)  
[GM7333K](#) [GM7350K](#) [XC6206P332MR](#) [HT7533](#) [LM7912S/TR](#) [LT1764S/TR](#) [LM7805T](#) [LM338T](#) [LM1117IMP-3.3/TR](#) [HT1117AM-3.3](#)  
[HT7550S](#) [AMS1117-3.3](#) [HT7150S](#) [78L12](#) [HT7550](#) [HT7533-1](#) [HXY6206I-2.5](#) [HT7133](#) [HT7533S](#) [662K](#)