

Features

- Low power consumption
- Low temperature coefficient
- Built-in hysteresis characteristic
- High input voltage (up to 15V)
- Output voltage accuracy: tolerance $\pm 1\%$ or $\pm 2\%$
- TO92, SOT89, SOT23 and SOT23-3 package

Applications

- Battery checkers
- Level selectors
- Power failure detectors
- Microcomputer reset
- Battery memory backup
- Non-volatile RAM signal storage protectors

General Description

The H70XXA-1 series devices are a set of three terminal low power voltage detectors implemented in CMOS technology. Each voltage detector in the series detects a particular fixed voltage ranging from 2.2V to 7.0V. The voltage detectors consist of a high-precision and low power consumption standard voltage source as well as a comparator,

hysteresis circuit, and an output driver. CMOS technology ensures low power consumption.

Although designed primarily as fixed voltage detectors, these devices can be used with external components to detect user specified threshold voltages.

Selection Table

Part No.	Detectable Voltage	Hysteresis Width	Tolerance	Package	Marking
H7022A-1	2.2V	0.11V	$\pm 2\%$	TO92 SOT89	70XXA-1 (for TO92) 70XXA-1 (for SOT89)
H7024A-1	2.4V	0.12V	$\pm 2\%$		
H7027A-1	2.7V	0.135V	$\pm 2\%$		
H7030A-1	3.0V	0.15V	$\pm 2\%$		
H7033A-1	3.3V	0.165V	$\pm 2\%$		
H7036A-1	3.6V	0.18V	$\pm 2\%$		
H7039A-1	3.9V	0.195V	$\pm 2\%$		
H7040A-1	4.0V	0.2V	$\pm 2\%$		
H7044A-1	4.4V	0.22V	$\pm 2\%$		
H7050A-1	5.0V	0.25V	$\pm 2\%$		
H7070A-1	7.0V	0.35V	$\pm 2\%$		

Note: For lead free devices, TO92 package will add a “#” mark at the end of the date code, whereas SOT89 packages will add a “#” mark at the end of the marking.

Typical Application Circuits

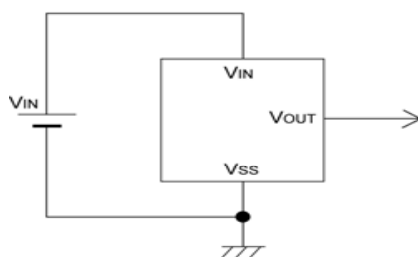

CMOS Output

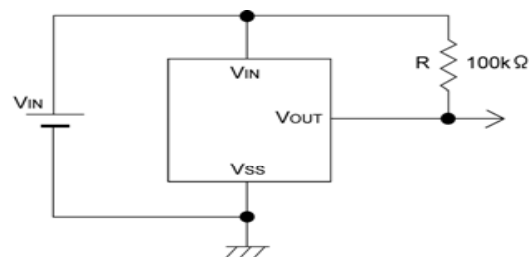

N-ch Open Drain Output

Order Information

H70①②A-1③④⑤

Designator	Symbol	Description
① ②	Integer	Output Voltage(2.2~7.0V)
③	N	NMOS
	C	CMOS
④	T	Package:TO-92
	P	Package:SOT89
	M	Package:SOT23-3
	N	Package:SOT23
⑤	R	RoHS / Pb Free
	G	Halogen Free

Block Diagram

(1) CMOS Output

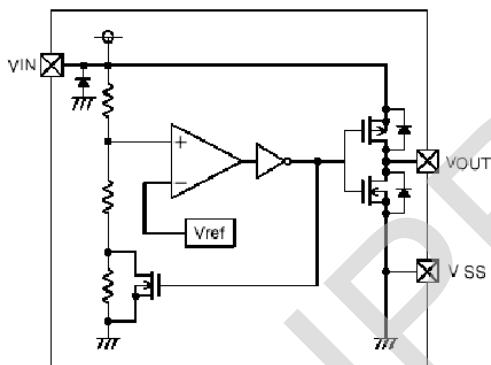

(2) N-ch Open Drain Output

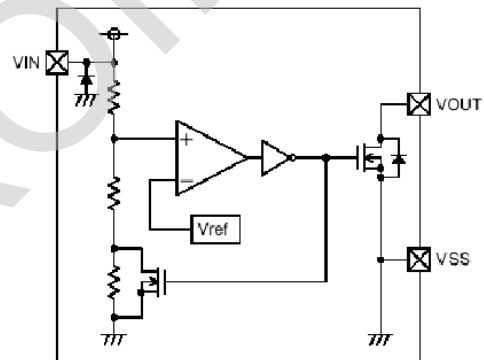

Output Table & Curve

V_{DD}	$V_{DD} > V_{DET}(+)$	$V_{DD} \leq V_{DET}(-)$
V_{OUT}	Hi-Z	V_{SS}

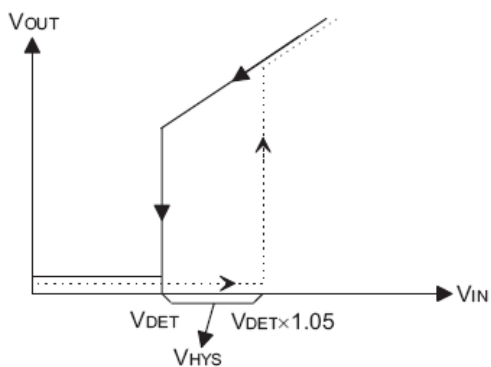

Dash line ... V_{IN} from Lo \rightarrow Hi
Solid line ... V_{IN} from Hi \rightarrow Lo

Pin Assignment

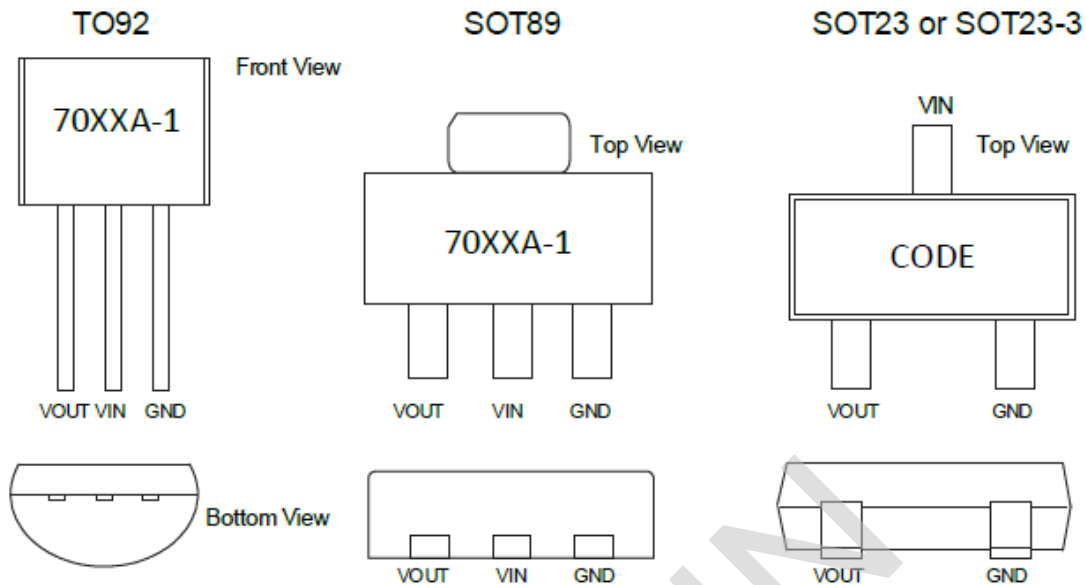

Absolute Maximum Ratings

Supply Voltage	-0.3V to 16V	Storage Temperature	-50°C to 125°C
Operating Temperature	-40°C to 85°C		

Note: These are stress ratings only. Stresses exceeding the range specified under “Absolute Maximum Ratings” may cause substantial damage to the device. Functional operation of this device at other conditions beyond those listed in the specification is not implied and prolonged exposure to extreme conditions may affect device reliability.

Thermal Information

Symbol	Parameter	Package	Max.	Unit
θ_{JA}	Thermal Resistance (Junction to Ambient) (Assume no ambient airflow, no heat sink)	SOT23	500	°C/W
		SOT89	200	°C/W
		TO92	200	°C/W
P_D	Power Dissipation	SOT23	0.20	W
		SOT89	0.50	W
		TO92	0.50	W

Note: P_D is measured at $T_a = 25^\circ\text{C}$

Electrical Characteristics

H7022A-1XXX
Ta=25°C

Symbol	Parameter	Test Conditions		Min.	Typ.	Max.	Unit
		V _{DD}	Conditions				
V _{DET}	Detection Voltage	-	-	2.156	2.200	2.244	V
V _{HYS}	Hysteresis Width	-	-	0.02 V _{DET}	0.05 V _{DET}	0.1 V _{DET}	V
I _{DD}	Operating Current	8V	No Load	-	2	3	μA
V _{DD}	Operating Voltage	-	-	1.5	-	16	V
I _{OL}	Output Sink Current	2V	V _{OUT} =0.2V	0.5	1	-	mA
$\frac{\Delta V_{DET}}{\Delta T_a}$	Temperature Coefficient	-	0°C < Ta < 70°C	-	±0.9	-	mV/°C

H7024A-1XXX
Ta=25°C

Symbol	Parameter	Test Conditions		Min.	Typ.	Max.	Unit
		V _{DD}	Conditions				
V _{DET}	Detection Voltage	-	-	2.352	2.400	2.448	V
V _{HYS}	Hysteresis Width	-	-	0.02 V _{DET}	0.05 V _{DET}	0.1 V _{DET}	V
I _{DD}	Operating Current	8V	No Load	-	2	3	μA
V _{DD}	Operating Voltage	-	-	1.5	-	16	V
I _{OL}	Output Sink Current	2V	V _{OUT} =0.2V	0.5	1	-	mA
$\frac{\Delta V_{DET}}{\Delta T_a}$	Temperature Coefficient	-	0°C < Ta < 70°C	-	±0.9	-	mV/°C

H7027A-1XXX
Ta=25°C

Symbol	Parameter	Test Conditions		Min.	Typ.	Max.	Unit
		V _{DD}	Conditions				
V _{DET}	Detection Voltage	-	-	2.646	2.700	2.754	V
V _{HYS}	Hysteresis Width	-	-	0.02 V _{DET}	0.05 V _{DET}	0.1 V _{DET}	V
I _{DD}	Operating Current	8V	No Load	-	2	3	μA
V _{DD}	Operating Voltage	-	-	1.5	-	16	V
I _{OL}	Output Sink Current	2V	V _{OUT} =0.2V	0.5	1	-	mA
$\frac{\Delta V_{DET}}{\Delta T_a}$	Temperature Coefficient	-	0°C<Ta<70°C	-	±0.9	-	mV/°C

H7030A-1XXX
Ta=25°C

Symbol	Parameter	Test Conditions		Min.	Typ.	Max.	Unit
		V _{DD}	Conditions				
V _{DET}	Detection Voltage	-	-	2.940	3.000	3.060	V
V _{HYS}	Hysteresis Width	-	-	0.02 V _{DET}	0.05 V _{DET}	0.1 V _{DET}	V
I _{DD}	Operating Current	8V	No Load	-	2	3	μA
V _{DD}	Operating Voltage	-	-	1.5	-	16	V
I _{OL}	Output Sink Current	2V	V _{OUT} =0.2V	1.2	2.5	-	mA
$\frac{\Delta V_{DET}}{\Delta T_a}$	Temperature Coefficient	-	0°C<Ta<70°C	-	±0.9	-	mV/°C

H7033A-1XXX
Ta=25°C

Symbol	Parameter	Test Conditions		Min.	Typ.	Max.	Unit
		V _{DD}	Conditions				
V _{DET}	Detection Voltage	-	-	3.234	3.300	3.366	V
V _{HYS}	Hysteresis Width	-	-	0.02 V _{DET}	0.05 V _{DET}	0.1 V _{DET}	V
I _{DD}	Operating Current	8V	No Load	-	2	3	μA
V _{DD}	Operating Voltage	-	-	1.5	-	16	V
I _{OL}	Output Sink Current	2V	V _{OUT} =0.2V	1.2	2.5	-	mA
$\frac{\Delta V_{DET}}{\Delta T_a}$	Temperature Coefficient	-	0°C<Ta<70°C	-	±0.9	-	mV/°C

H7036A-1XXX
Ta=25°C

Symbol	Parameter	Test Conditions		Min.	Typ.	Max.	Unit
		V _{DD}	Conditions				
V _{DET}	Detection Voltage	-	-	3.528	3.600	3.672	V
V _{HYS}	Hysteresis Width	-	-	0.02 V _{DET}	0.05 V _{DET}	0.1 V _{DET}	V
I _{DD}	Operating Current	8V	No Load	-	2	3	μA
V _{DD}	Operating Voltage	-	-	1.5	-	16	V
I _{OL}	Output Sink Current	2V	V _{OUT} =0.2V	1.2	2.5	-	mA
$\frac{\Delta V_{DET}}{\Delta T_a}$	Temperature Coefficient	-	0°C<Ta<70°C	-	±0.9	-	mV/°C

H7039A-1XXX
Ta=25°C

Symbol	Parameter	Test Conditions		Min.	Typ.	Max.	Unit
		V _{DD}	Conditions				
V _{DET}	Detection Voltage	-	-	3.822	3.900	3.978	V
V _{HYS}	Hysteresis Width	-	-	0.02 V _{DET}	0.05 V _{DET}	0.1 V _{DET}	V
I _{DD}	Operating Current	8V	No Load	-	2	3	μA
V _{DD}	Operating Voltage	-	-	1.5	-	16	V
I _{OL}	Output Sink Current	2V	V _{OUT} =0.2V	1.2	2.5	-	mA
$\frac{\Delta V_{DET}}{\Delta T_a}$	Temperature Coefficient	-	0°C < Ta < 70°C	-	±0.9	-	mV/°C

H7040A-1XXX
Ta=25°C

Symbol	Parameter	Test Conditions		Min.	Typ.	Max.	Unit
		V _{DD}	Conditions				
V _{DET}	Detection Voltage	-	-	3.920	4.000	4.080	V
V _{HYS}	Hysteresis Width	-	-	0.02 V _{DET}	0.05 V _{DET}	0.1 V _{DET}	V
I _{DD}	Operating Current	8V	No Load	-	2	3	μA
V _{DD}	Operating Voltage	-	-	1.5	-	16	V
I _{OL}	Output Sink Current	2V	V _{OUT} =0.2V	1.2	2.5	-	mA
$\frac{\Delta V_{DET}}{\Delta T_a}$	Temperature Coefficient	-	0°C < Ta < 70°C	-	±0.9	-	mV/°C

H7044A-1XXX
Ta=25°C

Symbol	Parameter	Test Conditions		Min.	Typ.	Max.	Unit
		V _{DD}	Conditions				
V _{DET}	Detection Voltage	-	-	4.312	4.400	4.488	V
V _{HYS}	Hysteresis Width	-	-	0.02 V _{DET}	0.05 V _{DET}	0.1 V _{DET}	V
I _{DD}	Operating Current	8V	No Load	-	2	3	μA
V _{DD}	Operating Voltage	-	-	1.5	-	16	V
I _{OL}	Output Sink Current	2V	V _{OUT} =0.2V	3	6	-	mA
$\frac{\Delta V_{DET}}{\Delta T_a}$	Temperature Coefficient	-	0°C < Ta < 70°C	-	±0.9	-	mV/°C

H7050A-1XXX
Ta=25°C

Symbol	Parameter	Test Conditions		Min.	Typ.	Max.	Unit
		V _{DD}	Conditions				
V _{DET}	Detection Voltage	-	-	4.900	5.000	5.100	V
V _{HYS}	Hysteresis Width	-	-	0.02 V _{DET}	0.05 V _{DET}	0.1 V _{DET}	V
I _{DD}	Operating Current	8V	No Load	-	2	3	μA
V _{DD}	Operating Voltage	-	-	1.5	-	16	V
I _{OL}	Output Sink Current	2V	V _{OUT} =0.2V	3	6	-	mA
$\frac{\Delta V_{DET}}{\Delta T_a}$	Temperature Coefficient	-	0°C < Ta < 70°C	-	±0.9	-	mV/°C

H7070A-1XXX

Ta=25°C

Symbol	Parameter	Test Conditions		Min.	Typ.	Max.	Unit
		V _{DD}	Conditions				
V _{DET}	Detection Voltage	-	-	6.860	7.000	7.140	V
V _{HYS}	Hysteresis Width	-	-	0.02 V _{DET}	0.05 V _{DET}	0.1 V _{DET}	V
I _{DD}	Operating Current	8V	No Load	-	2	3	μA
V _{DD}	Operating Voltage	-	-	1.5	-	16	V
I _{OL}	Output Sink Current	2V	V _{OUT} =0.2V	3	6	-	mA
$\frac{\Delta V_{DET}}{\Delta T_a}$	Temperature Coefficient	-	0°C < Ta < 70°C	-	±0.9	-	mV/°C

Application Circuits

Microcomputer Reset Circuit

Normally a reset circuit is required to protect the microcomputer system from malfunctions due to power line interruptions. The following examples show how different output Configurations perform a reset function in various systems.

NMOS open drain output application for separate power supply

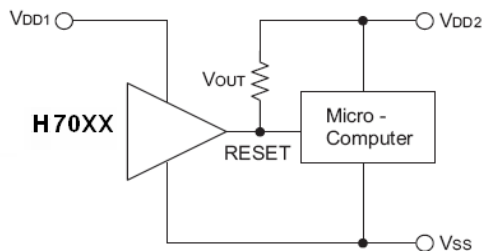

NMOS open drain output application with R-C delay

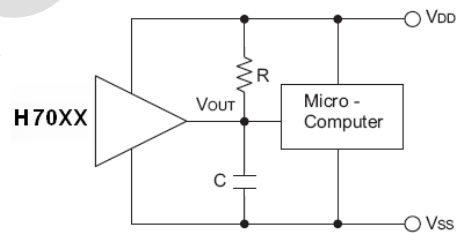

Power-on Reset Circuit

With several external components, the NMOS open drain type of the H70XXA-1 series can be used to perform a power-on reset function as shown:

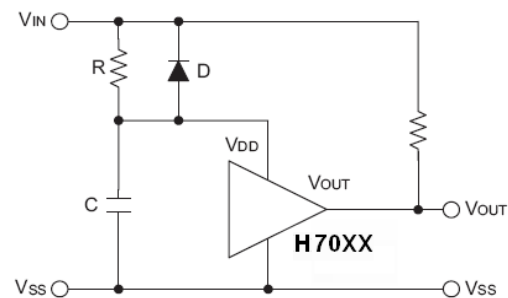

Low Power Voltage Detector

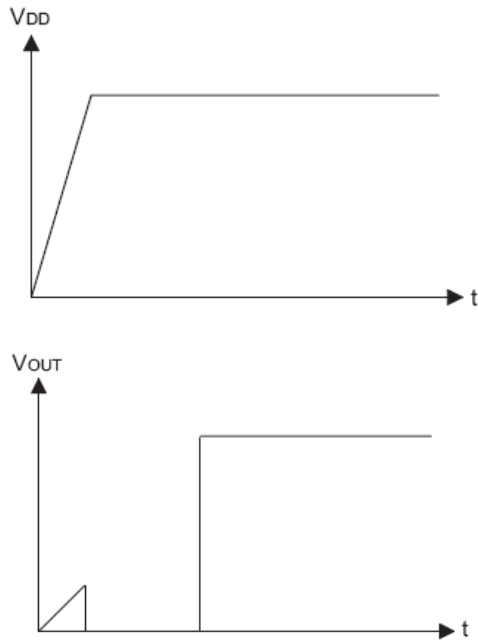

5V Power Line Monitoring Circuit

Generally, a minimum operating voltage of 4.5V is guaranteed in a 5V power line system. The H7044A-1YTR is recommended for use as 5V power line monitoring circuit.

5V power line monitor with power-on reset

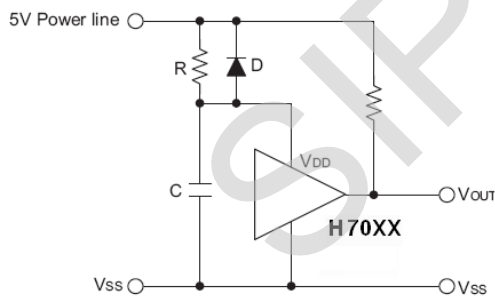

With 5V voltage regulator

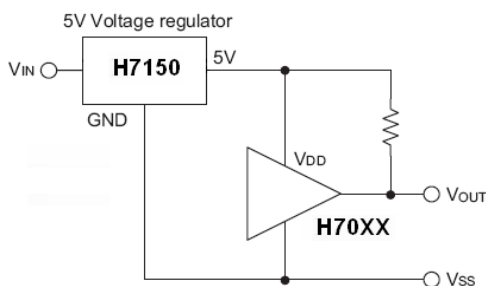

Change of Detectable Voltage

If the required voltage is not found in the standard product selection table, it

is possible to change it by using external resistance dividers or diodes. Varying the detectable voltage with a resistance divider

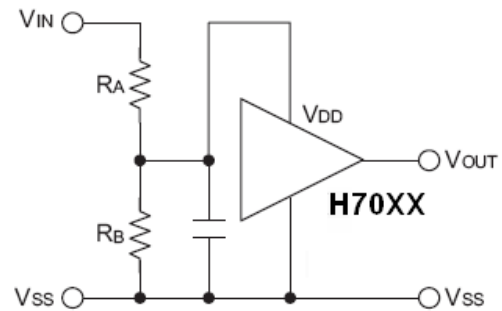

$$\text{Detectable voltage} = \frac{R_A + R_B}{R_B} \times V_{DET}$$

$$\text{Hysteresis width} = \frac{R_A + R_B}{R_B} \times V_{HYS}$$

Varying the detectable voltage with a diode

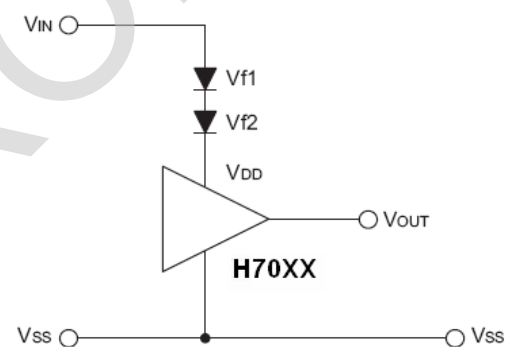

$$\text{Detectable Voltage} = V_{f1} + V_{f2} + V_{DET}$$

Malfunction Analysis

The following circuit demonstrates the way a circuit analyzes malfunctions by monitoring the variation or spike noise of power supply voltage.

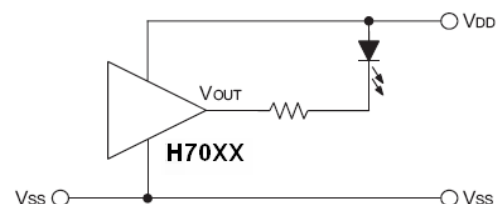

Charge Monitoring Circuit

The following circuit shows a charged monitor for protection against battery

deterioration by overcharging. When the voltage of the battery is higher than the set detectable voltage, the transistor turns onto bypass the charge current, protecting the battery from overcharging.

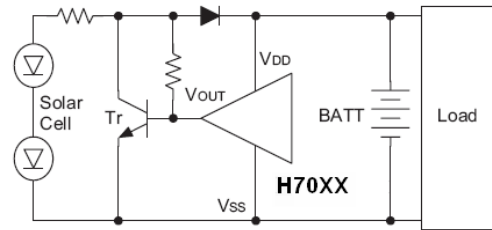

Level Selector

The following diagram illustrates a logic level selector.

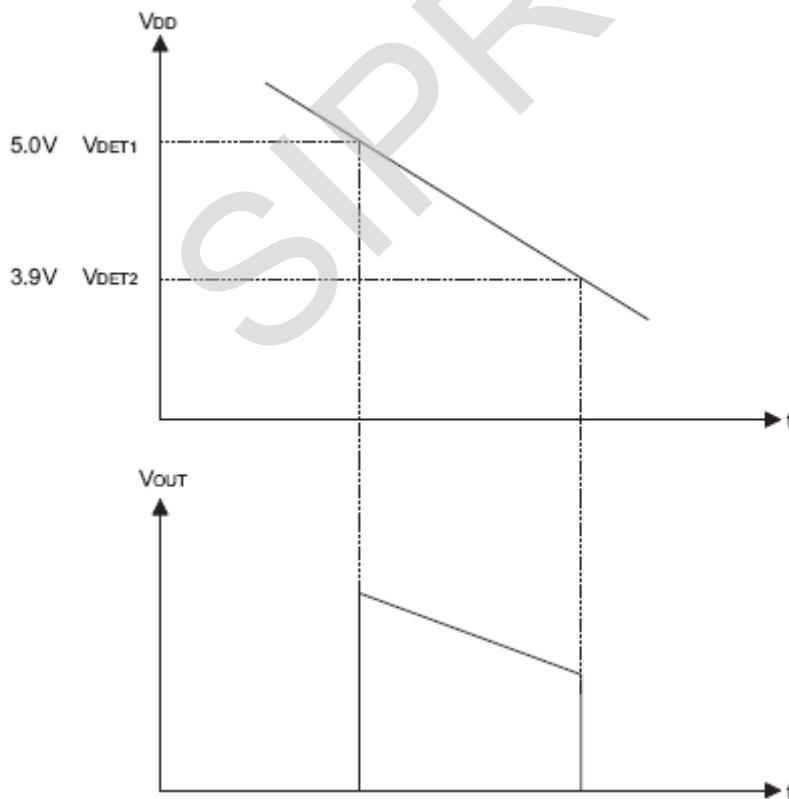
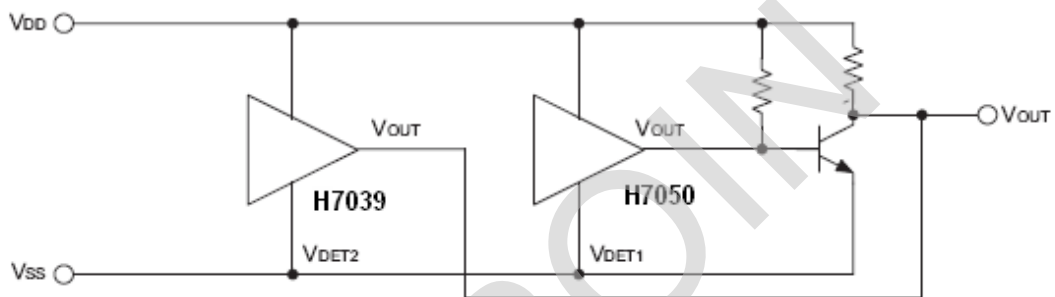

Package Information

3-pin TO92 Outline Dimensions

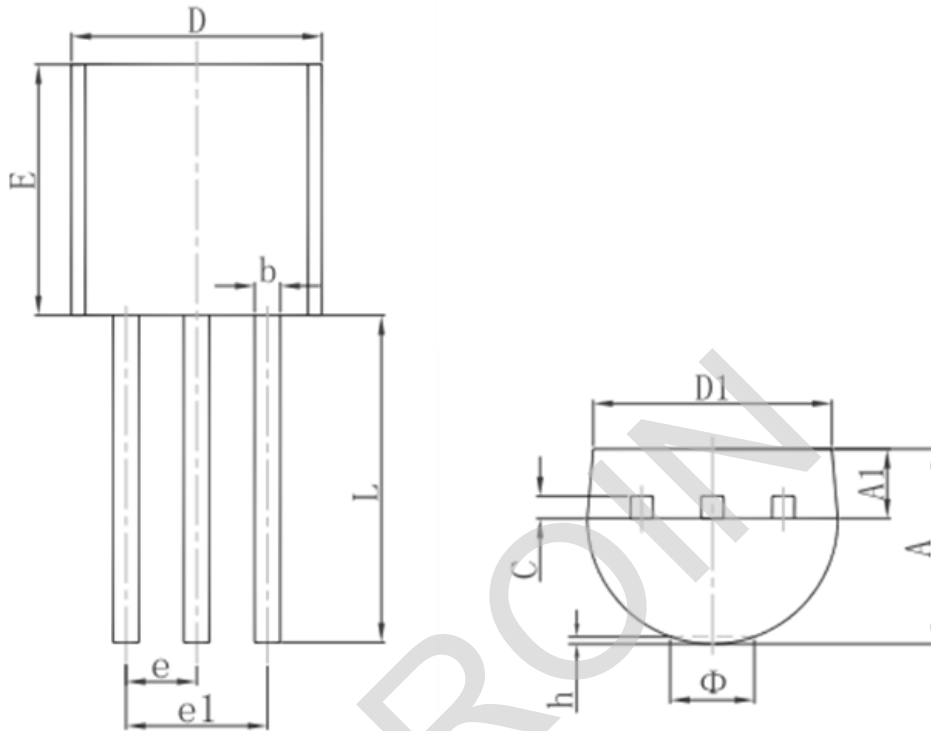

Symbol	Dimensions In Millimeters		Dimensions In Inches	
	Min.	Max.	Min.	Max.
A	3.300	3.700	0.130	0.146
A1	1.100	1.400	0.043	0.055
b	0.380	0.550	0.015	0.022
c	0.360	0.510	0.014	0.020
D	4.300	4.700	0.169	0.185
D1	3.430		0.135	
E	4.300	4.700	0.169	0.185
e	1.270 TYP.		0.050 TYP.	
e1	2.440	2.640	0.096	0.104
L	14.100	14.500	0.555	0.571
Φ		1.600		0.063
h	0.000	0.380	0.000	0.015

3-pin SOT89 Outline Dimensions

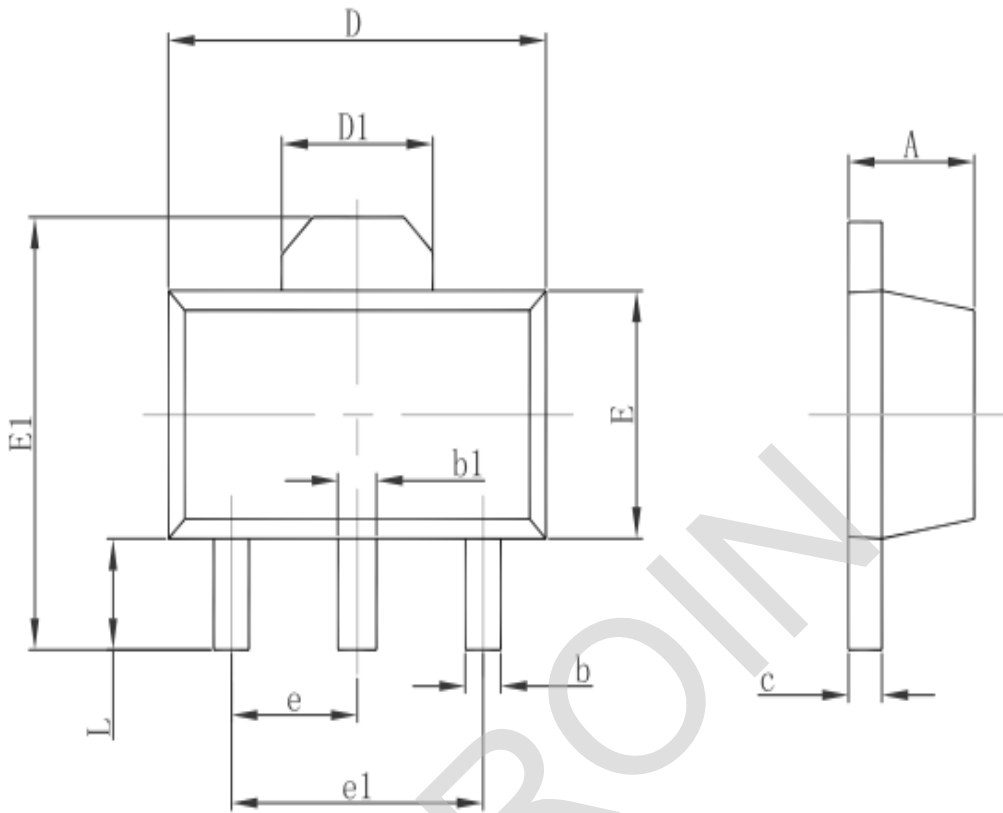

Symbol	Dimensions In Millimeters		Dimensions In Inches	
	Min.	Max.	Min.	Max.
A	1.400	1.600	0.055	0.063
b	0.320	0.520	0.013	0.020
b1	0.400	0.580	0.016	0.023
c	0.350	0.440	0.014	0.017
D	4.400	4.600	0.173	0.181
D1	1.550 REF.		0.061 REF.	
E	2.300	2.600	0.091	0.102
E1	3.940	4.250	0.155	0.167
e	1.500 TYP.		0.060 TYP.	
e1	3.000 TYP.		0.118 TYP.	
L	0.900	1.200	0.035	0.047

3-pin SOT23-3 Outline Dimensions

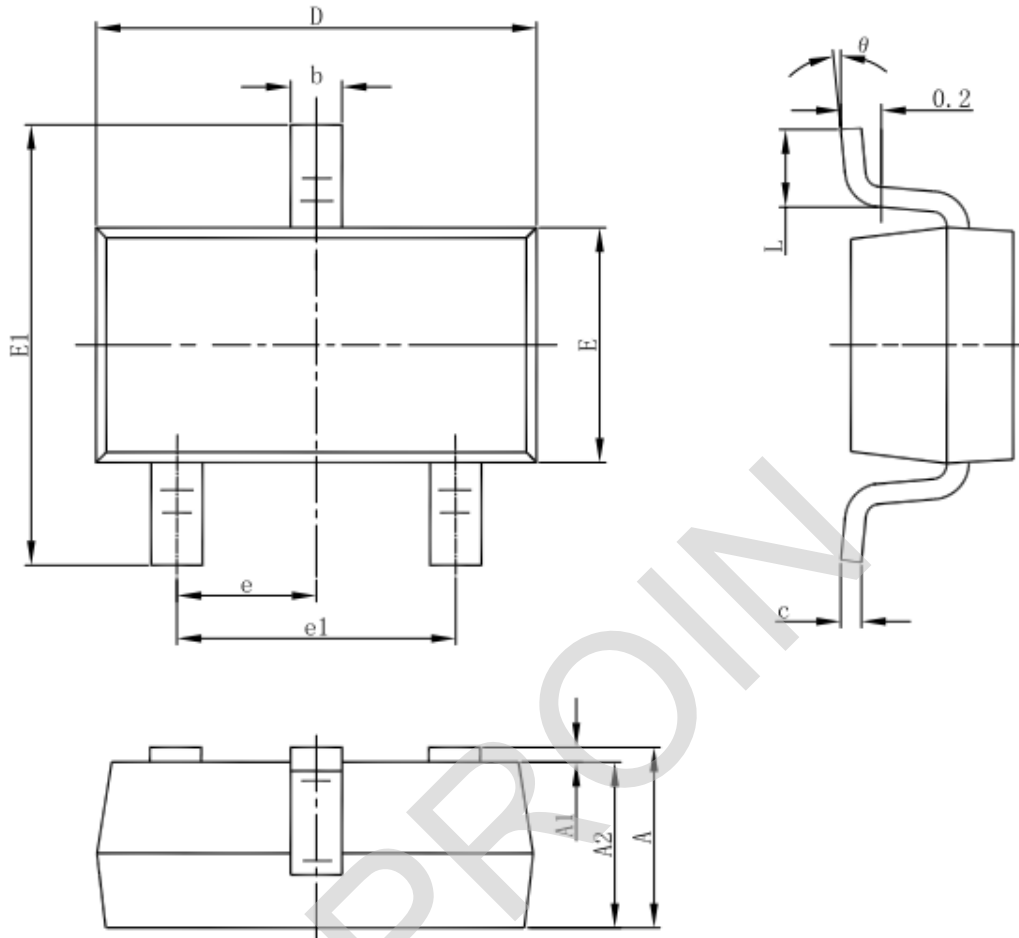

Symbol	Dimensions In Millimeters		Dimensions In Inches	
	Min	Max	Min	Max
A	1.050	1.250	0.041	0.049
A1	0.000	0.100	0.000	0.004
A2	1.050	1.150	0.041	0.045
b	0.300	0.500	0.012	0.020
c	0.100	0.200	0.004	0.008
D	2.820	3.020	0.111	0.119
E	1.500	1.700	0.059	0.067
E1	2.650	2.950	0.104	0.116
e	0.950(BSC)		0.037(BSC)	
e1	1.800	2.000	0.071	0.079
L	0.300	0.600	0.012	0.024
theta	0°	8°	0°	8°

3-pin SOT23 Outline Dimensions

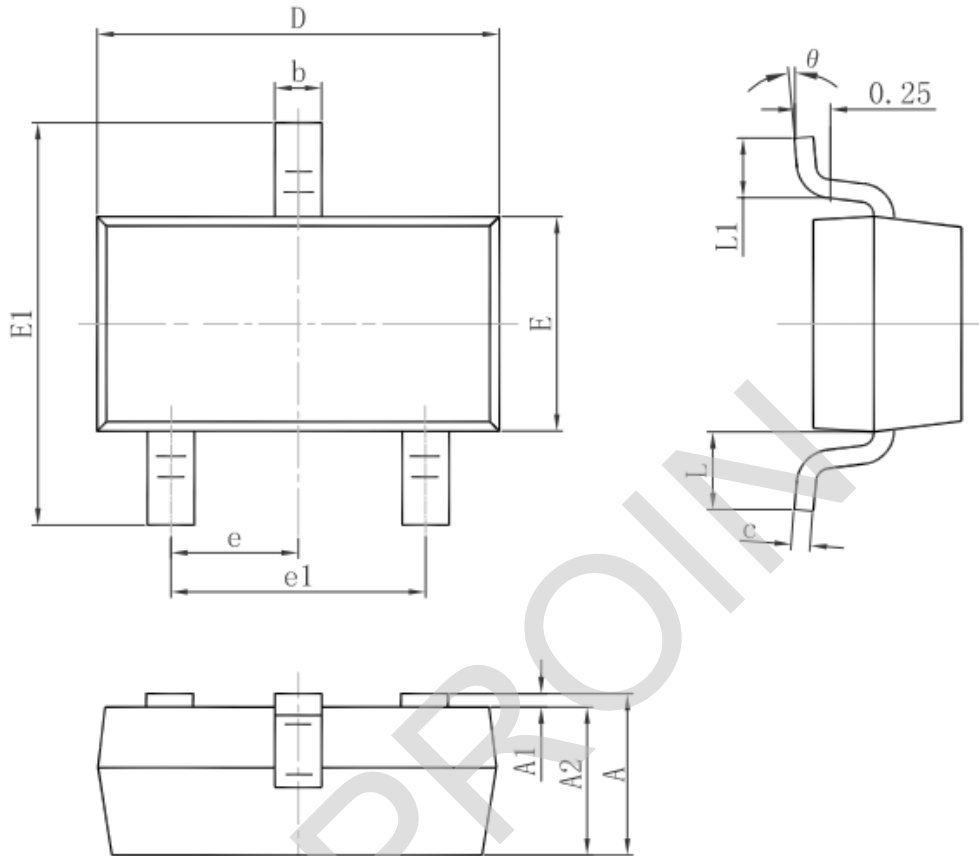

Symbol	Dimensions In Millimeters		Dimensions In Inches	
	Min.	Max.	Min.	Max.
A	0.900	1.150	0.035	0.045
A1	0.000	0.100	0.000	0.004
A2	0.900	1.050	0.035	0.041
b	0.300	0.500	0.012	0.020
c	0.080	0.150	0.003	0.006
D	2.800	3.000	0.110	0.118
E	1.200	1.400	0.047	0.055
E1	2.250	2.550	0.089	0.100
e	0.950 TYP.		0.037 TYP.	
e1	1.800	2.000	0.071	0.079
L	0.550 REF.		0.022 REF.	
L1	0.300	0.500	0.012	0.020
θ	0°	8°	0°	8°

X-ON Electronics

Largest Supplier of Electrical and Electronic Components

Click to view similar products for [Microprocessors - MPU category](#):

Click to view products by [Siproin manufacturer](#):

Other Similar products are found below :

[MCIMX6D5EYM12AD](#) [A2C00010998 A](#) [ALXD800EEXJCVD C3](#) [LS1020ASE7KQB](#) [LS1020AXE7KQB](#) [A2C00010729 A](#)
[T1022NSE7MQB](#) [T1024NXE7PQA](#) [T1042NSN7WQB](#) [MPC8313EVRADDC](#) [BOXSTCK1A8LFCL](#) [LS1021ASE7KQB](#) [LS1021ASN7KQB](#)
[T1024NXN7MQA](#) [T2080NXE8MQB](#) [T2080NXN8PTB](#) [MCIMX6L3EVN10AB](#) [T2080NXE8PTB](#) [T1024NXE7MQA](#) [CM8063501521600S](#)
[R19L](#) [LS1043AXE7MQB](#) [T1024NXN7PQA](#) [LS1043ASE7QQB](#) [LS1012AXE7HKA](#) [T4240NSN7PQB](#) [MVF30NN152CKU26](#)
[FH8067303534005S](#) [R3ZM](#) [R9A07G044L24GBG#AC0](#) [SVF311R3K2CKU2](#) [HW8076502640002S](#) [R38F](#) [R7S721030VLFP#AA0](#)
[M0516LBN](#) [MCF5208CVM166](#) [MCIMX6S6AVM08AC](#) [MCIMX6U5DVM10AC](#) [TEN54LSDV23GME](#) [MC68302AG33C](#) [MC68302EH16C](#)
[MCF5233CVM150](#) [MCIMX6D6AVT10AD](#) [MCIMX6G1CVM05AB](#) [MPC8314ECVRAGDA](#) [MPC8314VRAGDA](#) [MPC8315VRAGDA](#)
[MPC8541VTAPF](#) [PIC16F1828-I/SS](#) [PIC16F690T-I/SS](#) [PIC16F877-20/PQ](#) [PIC16F727-I/PT](#) [PIC16F1823-I/SL](#)