

Features

- Standby Mode: 0.1uA
- Low voltage drop:
0.12V@100mA@VOUT=3.3V(Typ.)
- Low temperature coefficient
- High input voltage (up to 8V)
- Output voltage accuracy: tolerance $\pm 2\%$
- SOT23-5 package

Applications

- Battery-powered equipment
- Communication equipment
- Mobile phones
- Portable games
- Cameras, Video cameras
- Reference voltage sources

General Description

The H7210 series are highly accurate, low noise, CMOS LDO Voltage Regulators. Offering low output noise, high ripple rejection ratio, low dropout and very fast turn-on times, the H7210 series is ideal for today's cutting edge mobile phone. Internally the H7210 includes a reference voltage source, error amplifiers, driver transistors, current limiters and phase compensators.

The output voltage is set by current trimming. Voltages are selectable in 100mV steps within a range of 1.2V to 5.0V.

When the CE input pin is low, the fast discharge channel can pass, a built-in pull-down resistor pulls the output voltage low. Fast

discharge function optional.

The H7210 series is also fully compatible with low ESR ceramic capacitors, reducing cost and improving output stability. This high level of output stability is maintained even during frequent load fluctuations, due to the excellent transient response performance and high PSRR achieved across a broad range of frequencies. The CE function allows the output of regulator to be turned off, resulting in greatly reduced power consumption.

Order Information

H7210-①②③④

Designator	Symbol	Description
①② (Stand for output voltage:1.2V~5V)	12	1.2V
	15	1.5V
	18	1.8V
	25	2.5V
	28	2.8V
	30	3.0V
	33	3.3V
③ (Stand for package)	M5	SOT23-5
④	R	RoHS / Pb Free

Note: "①②" stands for output voltages. Other voltages can be specially customized

Typical Application Circuit

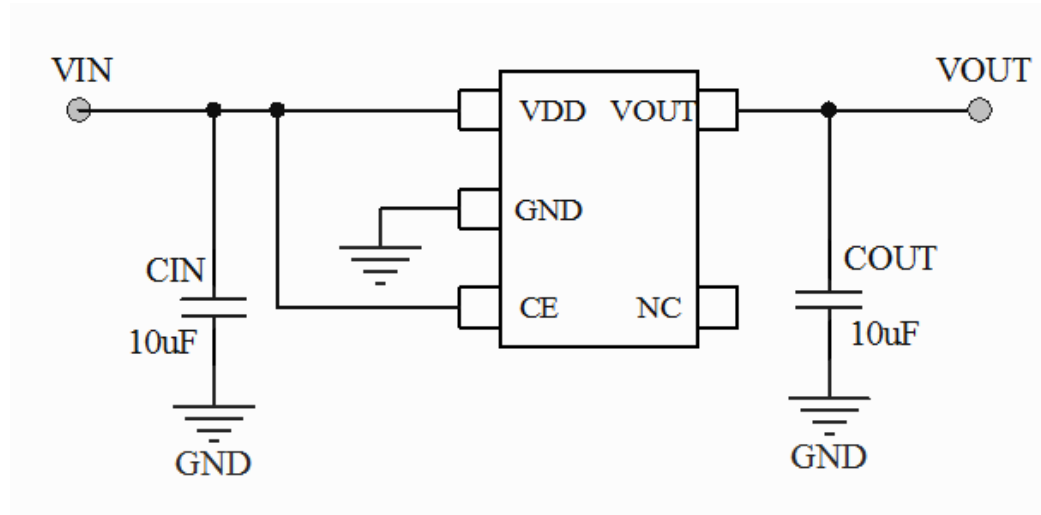

Package and Pin assignment

SOT23-5 (Top View)

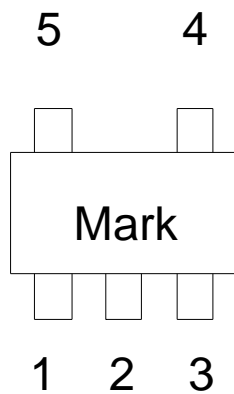

H7210-XXM5R series (SOT23-5 PKG)

PIN NUMBER	SYMBOL	FUNCTION
1	V_{IN}	Power Input Pin
2	GND	Ground
3	CE	Chip Enable Pin
4	NC	No Connection
5	V_{OUT}	Output Pin

Marking Rule

MARKING	
VOLTAGE(V)	Package
	SOT23-5
1.2	BB=H3Y
1.5	BS=JHT
1.8	BC=E2H
2.5	BH=M6C
2.8	BJ=G6U
3.0	BK=C0Z
3.3	BE=A1D

Absolute Maximum Ratings

Supply Voltage-0.3V to 8V Storage Temperature-50°C to 125°C
 Operating Temperature-40°C to 85°C

Note: These are stress ratings only. Stresses exceeding the range specified under “Absolute Maximum Ratings” may cause substantial damage to the device. Functional operation of this device at other conditions beyond those listed in the specification is not implied and prolonged exposure to extreme conditions may affect device reliability.

Thermal Information

Note: P_D is measured at T_a= 25°C

Symbol	Parameter	Package	Max.	Unit
θ_{JA}	Thermal Resistance (Junction to Ambient) (Assume no ambient airflow, no heat sink)	SOT23-5	500	°C/W
P _D	Power Dissipation	SOT23-5	0.25	W

Block Diagram

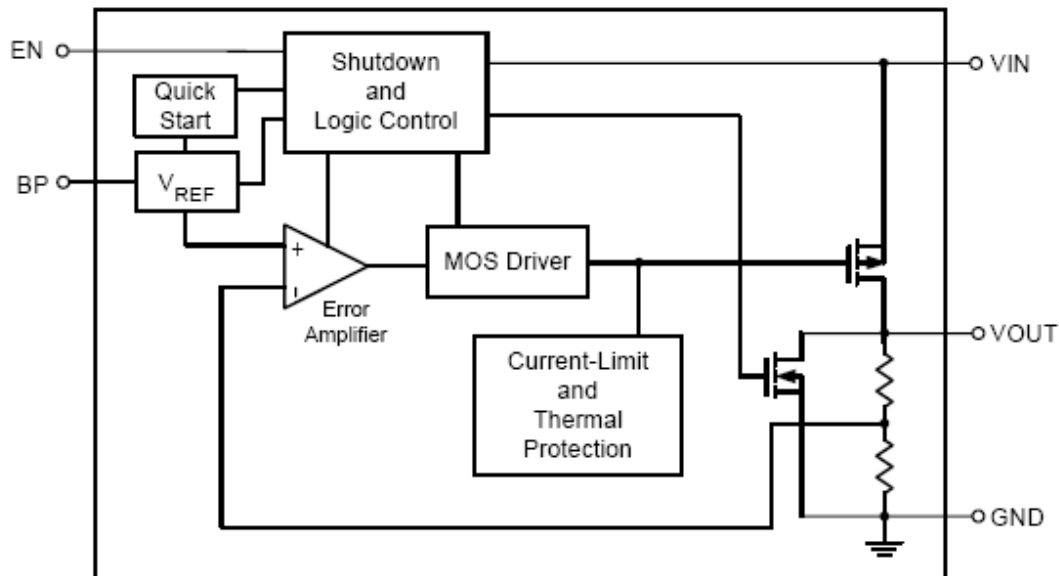

Recommended operating conditions (unless otherwise indicated, T_A = 25 ° C.)

Supply input voltage.....2.5V to 5.5V Junction temperature range.....-40°C to 125°C
 En input voltage..... 0V to 5.5V Ambient temperature range.....-40°C to 85°C

Electrical Characteristics

H7210 for any output voltage

($T_a=25^{\circ}\text{C}$)

Parameter	Symbol	Conditions	Min.	Typ.	Max.	Unit
Output Voltage	Vout	$V_{in}=V_{out}+1V$ $1.0\text{mA}\leq I_{out}\leq 30\text{mA}$	$V_{out}\times 0.98$	--	$V_{out}\times 1.02$	V
Output Current*1	Iout	$V_{in}-V_{out}=1V$	--	500	--	mA
Line Regulation	$\frac{\Delta V_{out}}{\Delta V_{in}}$	$4.3V\leq V_{in}\leq 8V$ $I_{out}=10\text{mA}$	--	0.05	0.2	%/V
Load Regulation	ΔV_{out}	$V_{in}=4.3V$ $1.0\text{mA}\leq I_{out}\leq 100\text{mA}$	--	10	30	mV
Output voltage Temperature Coefficiency	$\frac{\Delta V_{out}}{T_a-V_{out}}$	$I_{out}=30\text{mA}$ $0^{\circ}\text{C}\leq T_a\leq 70^{\circ}\text{C}$	--	± 100	--	Ppm/ $^{\circ}\text{C}$
Supply Current	I _{ss}	--	5	--	30	uA
Input Voltage	V _{in}	--	--	--	6	V
PSRR	PSRR	$F=100\text{Hz}$, $V_{in}=4.3V_{dc}+1V_{pp}$	--	60	--	dB

Operational Explanation

<Output Voltage Control>

The P-channel MOSFET is connected to the VOUT pin, driven by the subsequent output signal. The output voltage at the VOUT pin is controlled and stabilized by a system of negative feedback. The IC's internal circuitry can shut-down by the CE pin's signal

<Low ESR Capacitors>

With the H7210 series, a stable output voltage is achievable even if used with low ESR capacitors as a phase compensation circuit is built-in. In order to ensure the effectiveness of the phase compensation, we suggest that an output capacitor (C_L) is connected as close as possible to the output pin (VOUT) and the GND pin.

Please use an output capacitor with a capacitance value of at least 10uF. Also, please connect an input

capacitor (C_{IN}) of 10uF between the V_{IN} pin and the GND pin in order to ensure a stable power input. Stable phase compensation may not be ensured if the capacitor runs out capacitance when depending on bias and temperature. In case the capacitor depends on the bias and temperature, please make sure the capacitor can ensure the actual capacitance.

<CE Pin>

The IC's internal circuitry can be shutdown via the signal from the CE pin with the H7210 series. The operational logic of the IC's CE pin is selectable (please refer to the selection guide). Although the CE pin is equal to an inverter input with CMOS hysteresis, with either the pull-up or pull-down options, the CE pin input current will increase when the IC is in operation. We suggest that you use this IC with either a V_{IN} voltage or a V_{SS} voltage input at the CE pin. If this IC is used with the correct specifications for the CE pin, the operational logic is fixed and the IC will operate normally. However, supply current may increase as a result of through current in the IC's internal circuitry.

H7210-33M5R with fast discharge function

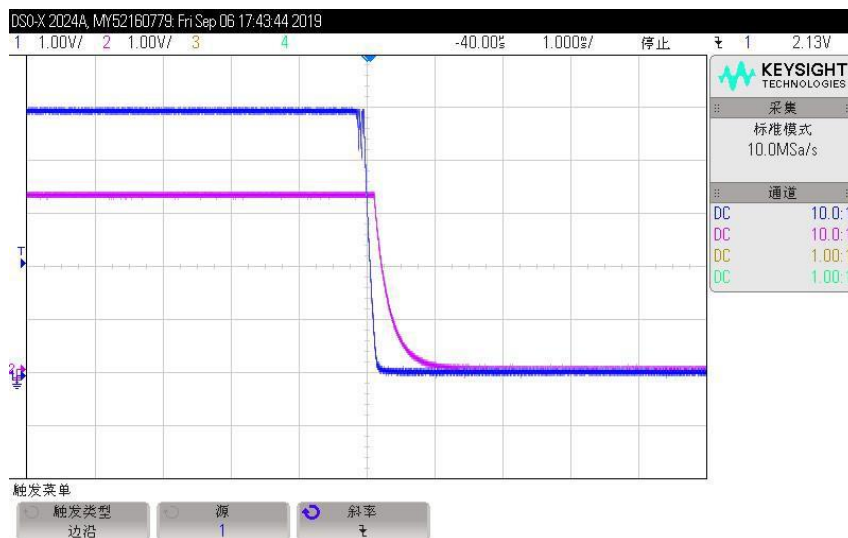

Notes on Use

1. Please use this IC within the stated absolute maximum ratings. The IC is liable to malfunction should the ratings be exceeded.
2. Where wiring impedance is high, operations may become unstable due to noise and/or phase lag depending on output current. Please keep the resistance low between V_{IN} and V_{SS} wiring in particular.
3. Please wire the input capacitor (C_{IN}) and the output capacitor (C_L) as close to the IC as possible.

Packaging Information

SOT23-5 Outline Dimensions

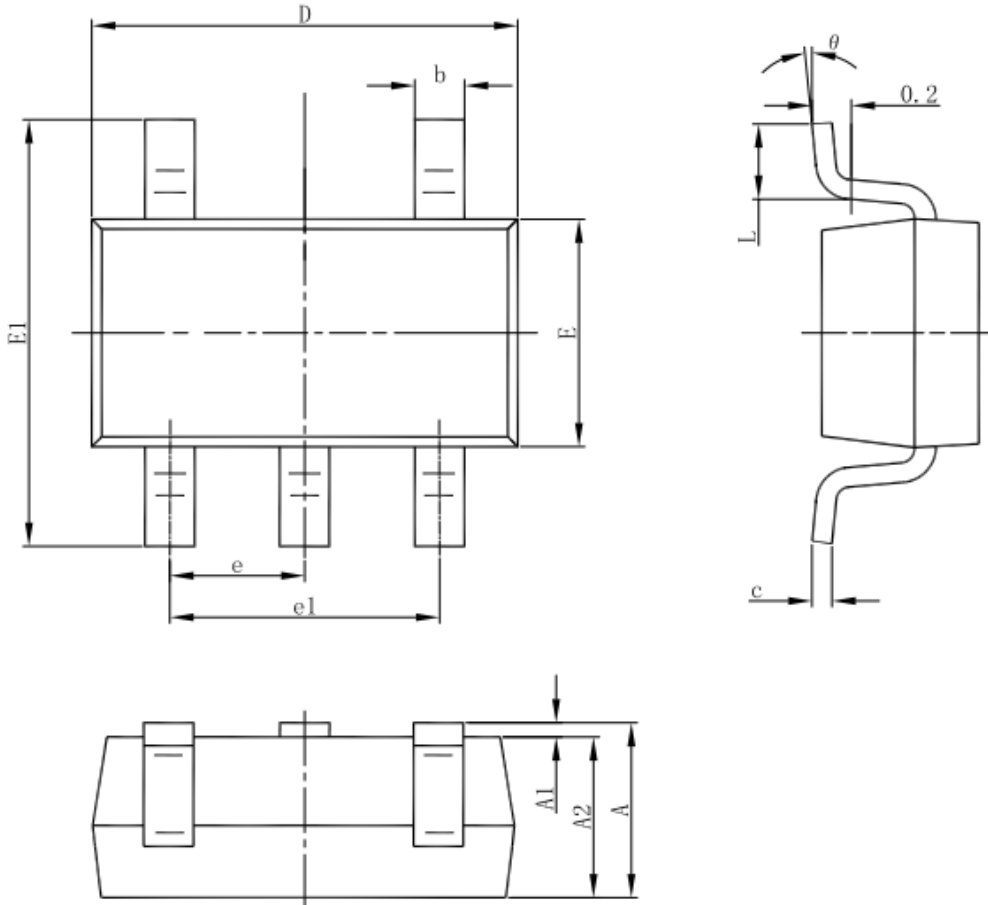

Symbol	Dimensions In Millimeters		Dimensions In Inches	
	Min	Max	Min	Max
A	1.050	1.250	0.041	0.049
A1	0.000	0.100	0.000	0.004
A2	1.050	1.150	0.041	0.045
b	0.300	0.500	0.012	0.020
c	0.100	0.200	0.004	0.008
D	2.820	3.020	0.111	0.119
E	1.500	1.700	0.059	0.067
E1	2.650	2.950	0.104	0.116
e	0.950(BSC)		0.037(BSC)	
e1	1.800	2.000	0.071	0.079
L	0.300	0.600	0.012	0.024
θ	0°	8°	0°	8°

X-ON Electronics

Largest Supplier of Electrical and Electronic Components

Click to view similar products for [Linear Voltage Regulators](#) category:

Click to view products by [Siproin](#) manufacturer:

Other Similar products are found below :

[LV5684PVD-XH](#) [MCDTSA6-2R](#) [L7815ACV-DG](#) [714954EB](#) [ZMR500QFTA](#) [BA033LBSG2-TR](#) [LV5680P-E](#) [L79M05T-E](#) [L78LR05D-MA-E](#) [NCV317MBTG](#) [NTE7227](#) [MP2018GZD-33-P](#) [MP2018GZD-5-P](#) [LV5680NPVC-XH](#) [LT1054CN8](#) [ZTS6538SE](#) [UA78L09CLP](#) [UA78L09CLPR](#) [CAT6221-PPTD-GT3](#) [MC78M09CDTRK](#) [NCV51190MNTAG](#) [78M05](#) [HT7150-1](#) [UM1540DB-18](#) [XC6234H281VR-G](#) [WL2834CA-6/TR](#) [TPL730F33-5TR](#) [TLS850F1TA](#) [V50](#) [TPS549B22RVFR](#) [UM1540DB-33](#) [WL9200P3-50B](#) [WL9100P3-33B](#) [WL9005D4-33](#) [XC6219B152MR](#) [WL2855K33-3/TR](#) [PJ54BM33SE](#) [PJ9500M25SA](#) [MD7218E33PC1](#) [H7533-2PR](#) [SK7812AU](#) [SD1A30](#) [78L33](#) [TP78L33T3](#) [L78L33ACUTR](#) [SK6513ST3A-50](#) [SK6054D4-09](#) [SK6054D4-18](#) [SK6054D4-11](#) [SK6054D4-10](#) [LM79L12F](#)