

## 400mA Current、15V Input Voltage LDO

### H72XX-1

#### General Description

The H72XX-1 series is a group of positive voltage output, three-pin regulators, that provide a high current even when the input/output voltage differential is small. Low power consumption and high accuracy is achieved through CMOS and laser trimming technologies.

The H72XX-1 consists of a high-precision voltage reference, an error amplification circuit, and a current limited output driver. Transient response to load variations have improved in comparison to the existing series. SOT89-3, SOT23-3 and SOT23-5 packages are

available.

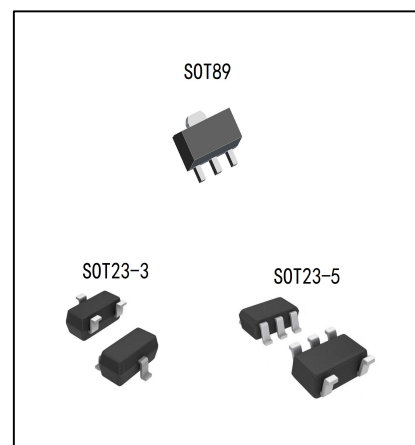

#### Features

- Low voltage drop: 0.17V@100mA
- Low Quiescent Current: 1.0uA
- High input voltage: 15V
- Low temperature coefficient
- Large Output Current: >0.40A
- Output voltage accuracy: tolerance  $\pm 2\%$
- Built-in current limiter
- SOT89, SOT23-3 and SOT23-5 packages

#### Applications

- Battery-powered equipment
- Hand-Hold Equipment
- GRS Receivers
- Wireless LAN

### Order specification

Part No	Package	Manner of Packing	Devices per bag/reel
H72XX-1PX	SOT89	Reel	1000PCS/reel
H72XX-1MX	SOT23-3	Reel	3000PCS/reel
H72XX-1M5X	SOT23-5	Reel	3000PCS/reel

### Description of selection

Part No	Output Voltage	Output Voltage Accuracy
H7215-1XX	1.5V	±2%
H7218-1XX	1.8V	±2%
H7225-1XX	2.5V	±2%
H7226-1XX	2.6V	±2%
H7227-1XX	2.7V	±2%
H7228-1XX	2.8V	±2%
H7230-1XX	3.0V	±2%
H7233-1XX	3.3V	±2%
H7236-1XX	3.6V	±2%
H7240-1XX	4.0V	±2%
H7245-1XX	4.5V	±2%
H7250-1XX	5.0V	±2%

### Type selection guide

H72①②-1③④

Designator	Symbol	Description
①②	Integer	Output Voltage(1.5V~5.0V)
③	P	Package:SOT89-3
	M	Package:SOT23-3
	M5	Package:SOT23-5
④	R	RoHS / Pb Free
	G	Halogen Free

Note:“①②” stands for output voltages. Other voltages can be specially customized.

## Block Diagram and Pin Arrangement Diagram

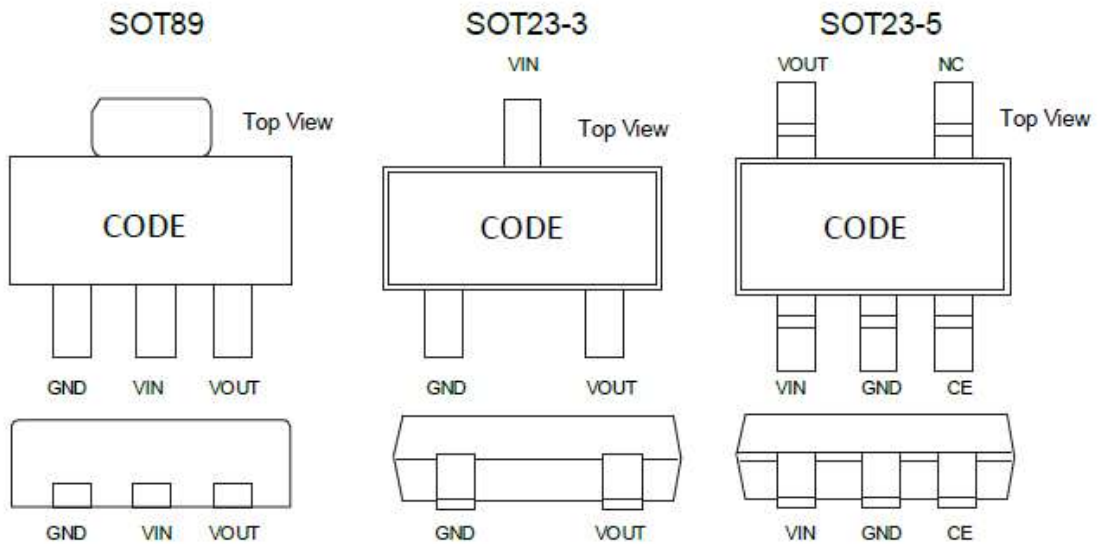
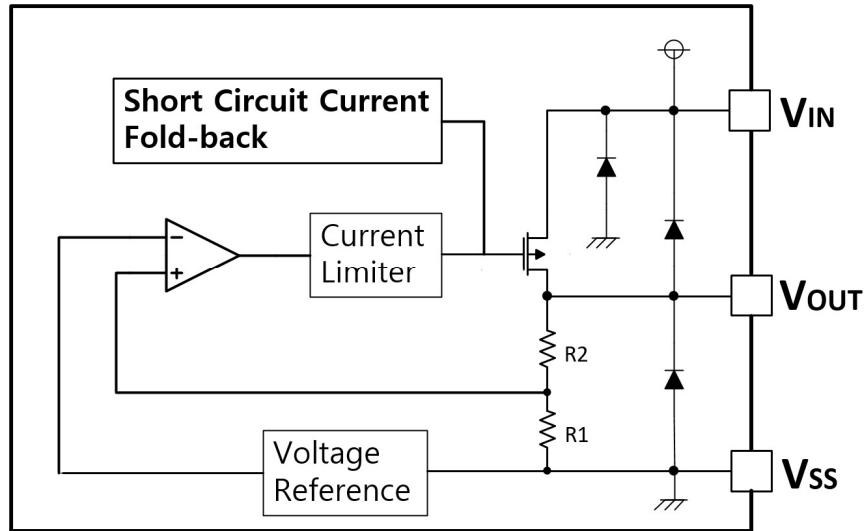

## Pin Assignment

Pin Name	Description
GND	Ground connection.
VIN	Supply Voltage Input.
VOUT	Output.
CE	Enable pin, active at high level.(SOT23-5)

## Functional Description

The H72XX-1 series is a group of positive voltage output, three-pin regulators, that provide a high current even when the input/output voltage differential is small. The H72XX-1 consists of a high-precision voltage reference, an error amplification circuit, and a current limited output driver.

## Absolute Maximum Ratings

Parameter	Symbol	Value	Unit
Supply Voltage Input	V <sub>IN</sub>	-0.3~18	V
Operating Temperature	T <sub>amb</sub>	-40~85	°C
Storage Temperature	T <sub>stg</sub>	-40~125	°C

Note: These are stress ratings only. Stresses exceeding the range specified under “Absolute Maximum Ratings” may cause substantial damage to the device. Functional operation of this device at other conditions beyond those listed in the specification is not implied and prolonged exposure to extreme conditions may affect device reliability.

## Electrical Characteristics

H72XX-1 for any output type (T<sub>a</sub>=25°C)

Parameter	Symbol	Test Conditions	Min.	Typ.	Max.	Unit
Output Voltage	V <sub>OUT</sub>	V <sub>IN</sub> =V <sub>OUT</sub> +1V 1.0mA ≤ I <sub>OUT</sub> ≤ 30mA	V <sub>OUT</sub> × 0.98	-	V <sub>OUT</sub> × 1.02	V
Output Current	I <sub>OUT</sub>	V <sub>IN</sub> - V <sub>OUT</sub> =1V	-	400	-	mA
Low dropout	V <sub>drop</sub>	Refer to the next table				
Line Regulation	$\frac{\Delta V_{OUT1}}{V_{IN} \times V_{OUT}}$	1.6V ≤ V <sub>IN</sub> ≤ 8V I <sub>OUT</sub> =100mA	-	0.05	0.2	%/V
Load Regulation	ΔV <sub>OUT</sub>	V <sub>IN</sub> =V <sub>OUT</sub> +1V 1.0mA ≤ I <sub>OUT</sub> ≤ 100mA	-	12	30	mV
Output Voltage Temperature Coefficiency	$\frac{\Delta V_{OUT}}{T_a \times V_{OUT}}$	I <sub>OUT</sub> =30mA 0°C ≤ T <sub>a</sub> ≤ 70°C	-	±100	-	ppm/°C
PSRR	PSRR	F=1KHz V <sub>IN</sub> =V <sub>OUT</sub> +1V	-	40	-	dB
Supply Current	I <sub>ss1</sub>	-	-	1	2	uA
Input Voltage	V <sub>IN</sub>		3.5	-	15	V

Electrical Characteristics by Output Voltage:

Output Voltage $V_{OUT}(V)$	Dropout Voltage $V_{dif}$ (V)		
	Conditions	Typ.	Max.
$V_{OUT} \leq 2.0V$	$I_{OUT}=60mA$	0.1	0.12
$2.0 < V_{OUT} \leq 3.0$	$I_{OUT}=80mA$	0.12	0.14
$3.0 < V_{OUT} \leq 4.0$	$I_{OUT}=100mA$	0.16	0.18
$4.0 < V_{OUT} \leq 5.0$		0.17	0.18
$3.0 < V_{OUT} \leq 4.0$	$I_{OUT}=200mA$	0.21	0.24
$4.0 < V_{OUT} \leq 6.0$		0.20	0.22
$3.0 < V_{OUT} \leq 4.0$	$I_{OUT}=500mA$	0.8	0.85
$4.0 < V_{OUT} \leq 6.0$		0.75	0.80

## Typical Performance Characteristics

(1) Output Voltage vs Input voltage

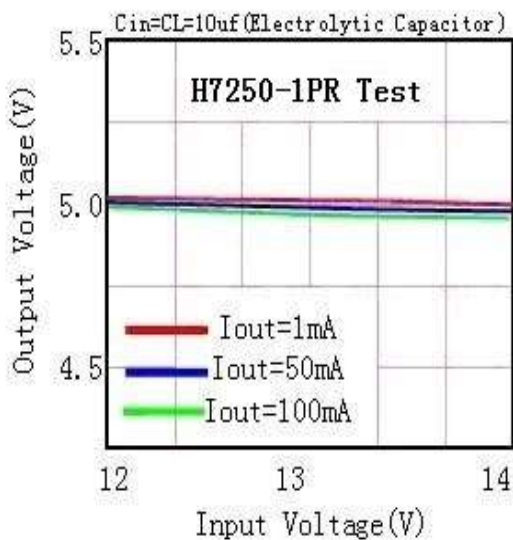
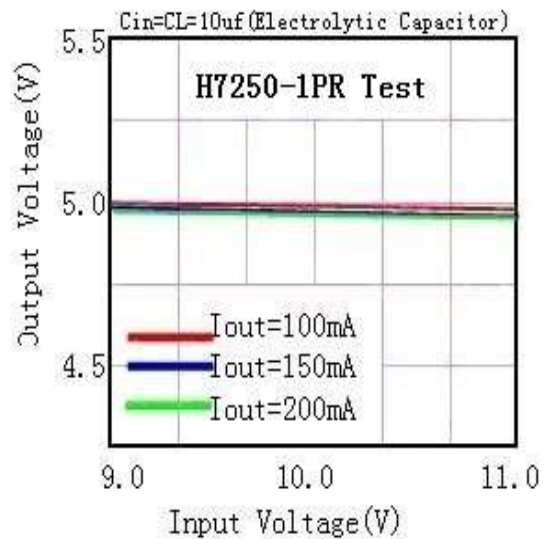
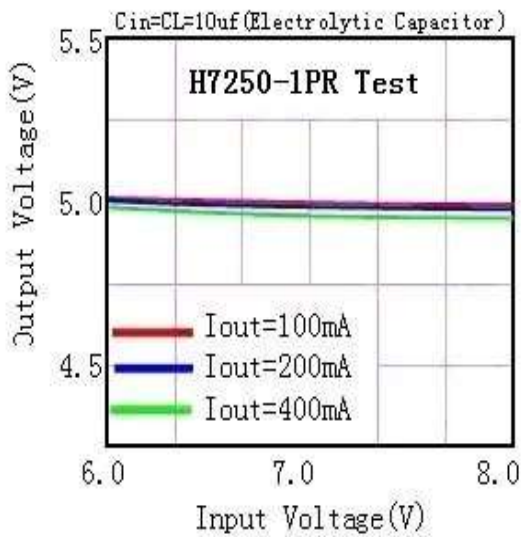

(2) Output Voltage vs. Output Current

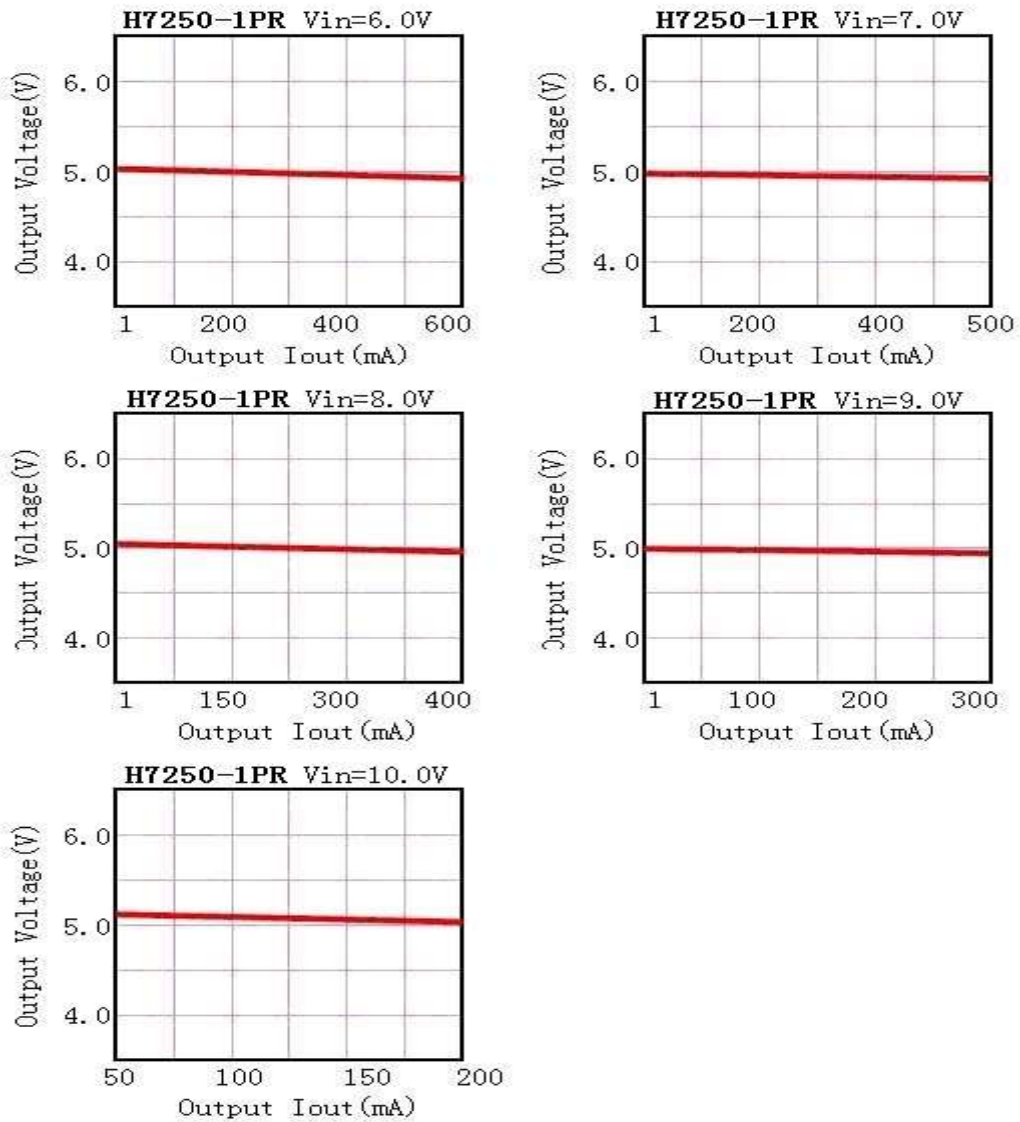

(3) Output Voltage vs. Ambient Temperature

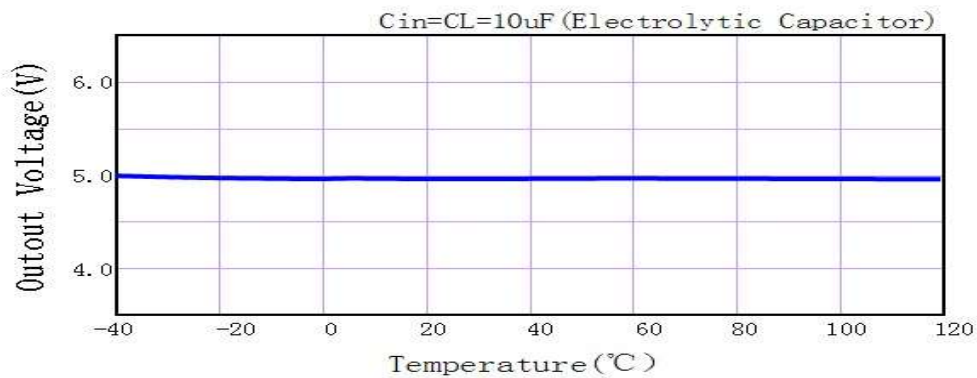

## Application Circuits

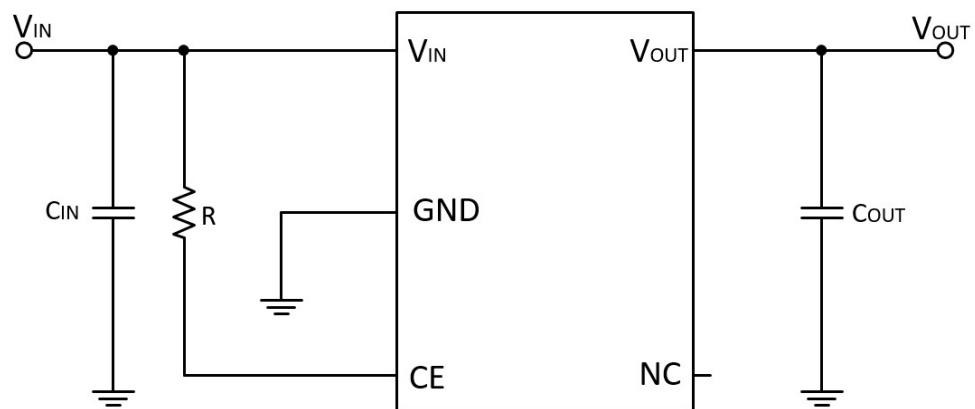
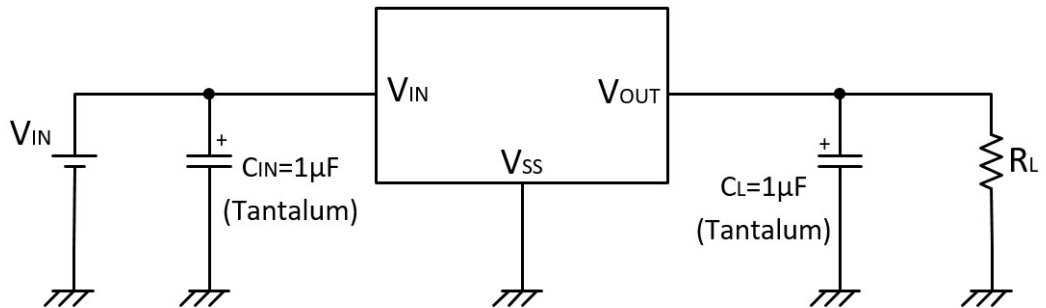

Note1: Input capacitor  $C_{IN}=1\mu F$ .

Note2: Output capacitor  $C_{OUT}=1\mu F$ .

Note3:  $R=10K\Omega$ .

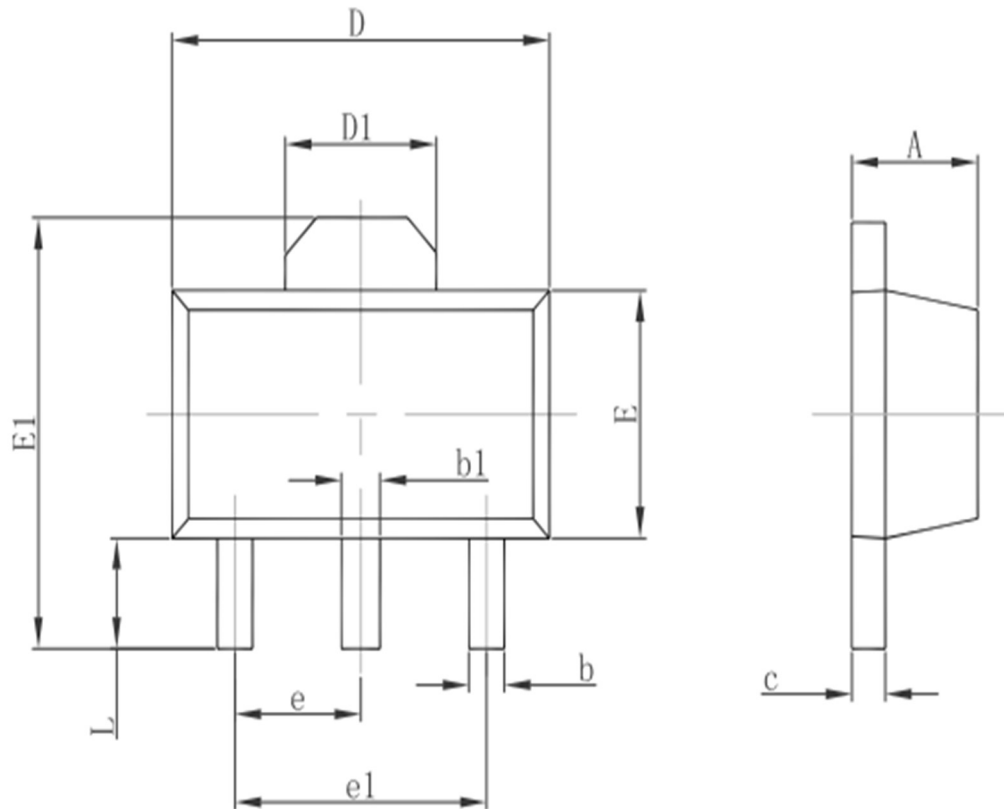
**Package Information (SOT89)**

Symbol	Dimensions In Millimeters		Dimensions In Inches	
	Min.	Max.	Min.	Max.
<b>A</b>	1.400	1.600	0.055	0.063
<b>b</b>	0.320	0.520	0.013	0.020
<b>b1</b>	0.400	0.580	0.016	0.023
<b>c</b>	0.350	0.440	0.014	0.017
<b>D</b>	4.400	4.600	0.173	0.181
<b>D1</b>	1.550REF.		0.061REF.	
<b>E</b>	2.300	2.600	0.091	0.102
<b>E1</b>	3.940	4.250	0.155	0.167
<b>e</b>	1.500TYP.		0.060TYP.	
<b>e1</b>	3.000TYP.		0.118TYP.	
<b>L</b>	0.900	1.200	0.035	0.047

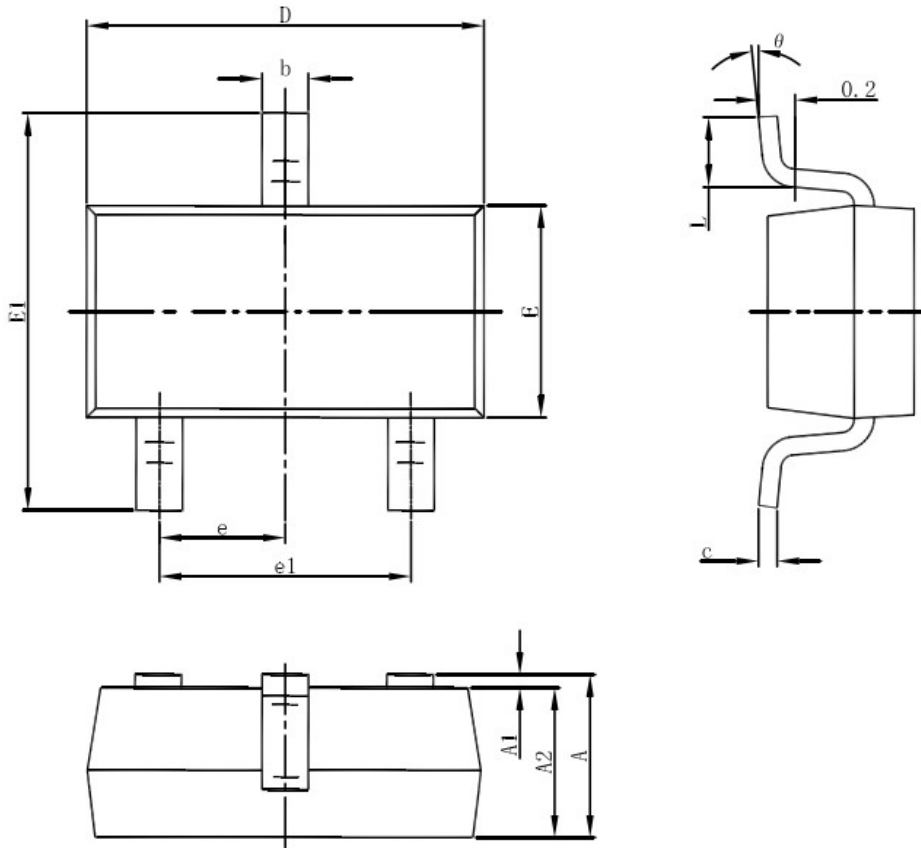

**Package Information (SOT23-3)**

Symbol	Dimensions In Millimeters		Dimensions In Inches	
	Min.	Max.	Min.	Max.
<b>A</b>	1.050	1.250	0.041	0.049
<b>A1</b>	0.000	0.100	0.000	0.004
<b>A2</b>	1.050	1.150	0.041	0.045
<b>b</b>	0.300	0.500	0.012	0.020
<b>c</b>	0.100	0.200	0.004	0.008
<b>D</b>	2.820	3.020	0.111	0.119
<b>E</b>	1.500	1.700	0.059	0.067
<b>E1</b>	2.650	2.950	0.104	0.116
<b>e</b>	0.950(BSC)		0.037(BSC)	
<b>e1</b>	1.800	2.000	0.071	0.079
<b>L</b>	0.300	0.600	0.012	0.024
<b><math>\theta</math></b>	0°	8°	0°	8°

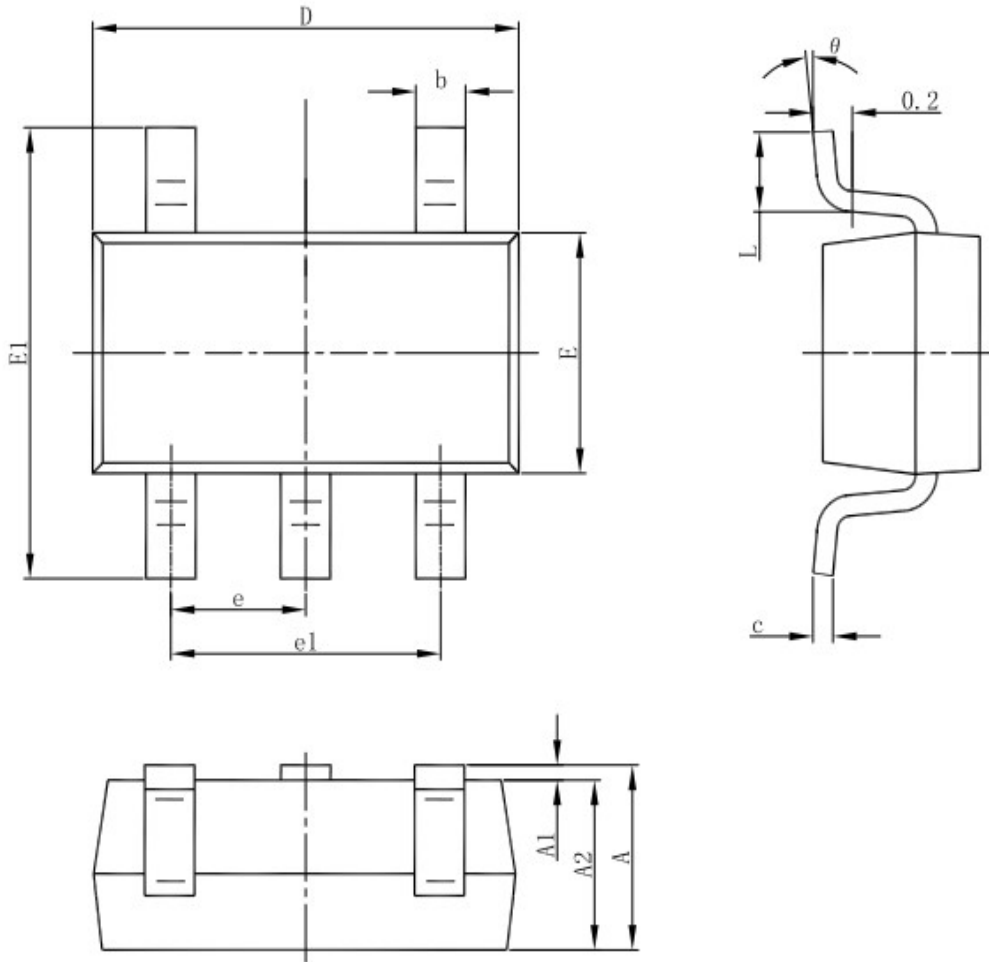
**Package Information (SOT23-5)**

Symbol	Dimensions In Millimeters		Dimensions In Inches	
	Min.	Max.	Min.	Max.
<b>A</b>	1.050	1.250	0.041	0.049
<b>A1</b>	0.000	0.100	0.000	0.004
<b>A2</b>	1.050	1.150	0.041	0.045
<b>b</b>	0.300	0.500	0.012	0.020
<b>c</b>	0.100	0.200	0.004	0.008
<b>D</b>	2.820	3.020	0.111	0.119
<b>E</b>	1.500	1.700	0.059	0.067
<b>E1</b>	2.650	2.950	0.104	0.116
<b>e</b>	0.950(BSC)		0.037(BSC)	
<b>e1</b>	1.800	2.000	0.071	0.079
<b>L</b>	0.300	0.600	0.012	0.024
<b>θ</b>	0°	8°	0°	8°

## Special Instructions

The company reserves the right of final interpretation of this specification.

## Version Change Description

---

Version: V2.0

Author: Yangyang

Time:

2021.10.11

Modify the record:

1. Re-typesetting the manual and checking some data
-

## X-ON Electronics

Largest Supplier of Electrical and Electronic Components

*Click to view similar products for [Linear Voltage Regulators](#) category:*

*Click to view products by [Siproin](#) manufacturer:*

Other Similar products are found below :

[LV5684PVD-XH](#) [MCDTSA6-2R](#) [L7815ACV-DG](#) [LV56801P-E](#) [UA7805CKC](#) [714954EB](#) [ZMR500QFTA](#) [BA033LBSG2-TR](#)  
[NCV78M05ABDTRKG](#) [LV5680P-E](#) [L79M05T-E](#) [L78LR05D-MA-E](#) [NCV317MBTG](#) [NTE7227](#) [MP2018GZD-33-P](#) [MP2018GZD-5-P](#)  
[LV5680NPVC-XH](#) [ZTS6538SE](#) [UA78L09CLP](#) [UA78L09CLPR](#) [CAT6221-PPTD-GT3](#) [MC78M09CDTRK](#) [NCV51190MNTAG](#)  
[BL1118CS8TR1833](#) [BL8563CKETR18](#) [BL8077CKETR33](#) [BL9153-33CC3TR](#) [BL9161G-15BADRN](#) [BL9161G-28BADRN](#)  
[BRCO7530MMC](#) [CJ7815B-TFN-ARG](#) [LM317C](#) [GM7333K](#) [GM7350K](#) [XC6206P332MR](#) [HT7533](#) [LM7912S/TR](#) [LT1764S/TR](#) [LM7805T](#)  
[LM338T](#) [LM1117IMP-3.3/TR](#) [HT1117AM-3.3](#) [HT7550S](#) [AMS1117-3.3](#) [HT7150S](#) [78L12](#) [HT7550](#) [HT7533-1](#) [HXY6206I-2.5](#) [HT7133](#)