

### Features

- Low power consumption
- Low voltage drop
- Low temperature coefficient
- Ultra low quiescent current: 2 $\mu$ A(typ.)
- High input voltage (up to 15V)
- Maximum output current: 250mA
- Output voltage accuracy: tolerance  $\pm 2\%$
- TO92, SOT89, SOT23 and SOT23-3 package

### Applications

- Battery-powered equipment
- Communication equipment
- Audio/Video equipment

### General Description

The H73XX-A series is a set of three-terminal low power high voltage regulators implemented in CMOS technology. They allow input voltages as high as 18V. The series features extremely low quiescent current which is typically 2 $\mu$ A. They are available with several fixed output voltages ranging from 2.5V to 5.0V. CMOS technology ensures low voltage drop and low quiescent current. Although designed primarily as fixed voltage regulators, these devices can be used with external components to obtain variable voltages and currents.

### Selection Table

Part No.	Output Voltage	Package	Marking
H7325-A	2.5V	TO92 SOT89 SOT23-3 SOT23	73XX-A(for TO92) 73XX-A(for SOT89) 3XX(for SOT23-3) 3XX(for SOT23)
H7328-A	2.8V		
H7330-A	3.0V		
H7333-A	3.3V		
H7336-A	3.6V		
H7340-A	4.0V		
H7344-A	4.4V		
H7350-A	5.0V		

Note: "XX" stands for output voltages. Other voltages can be specially customized.

### Order Information

H73①②-A③④

Designator	Symbol	Description
① ②	Integer	Output Voltage(2.5~5.0V)
③	T	Package:TO-92
	P	Package:SOT89-3
	N	Package:SOT23
	M	Package:SOT23-3
④	R	RoHS / Pb Free
	G	Halogen Free

Block Diagram

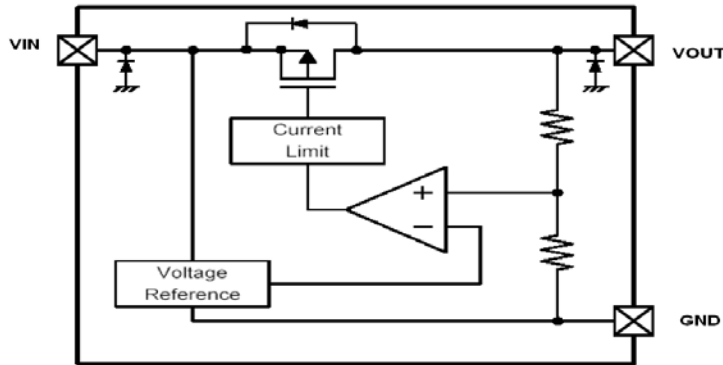

\*Diodes inside the circuit are an ESD protection diode and a parasitic diode.

Pin Assignment

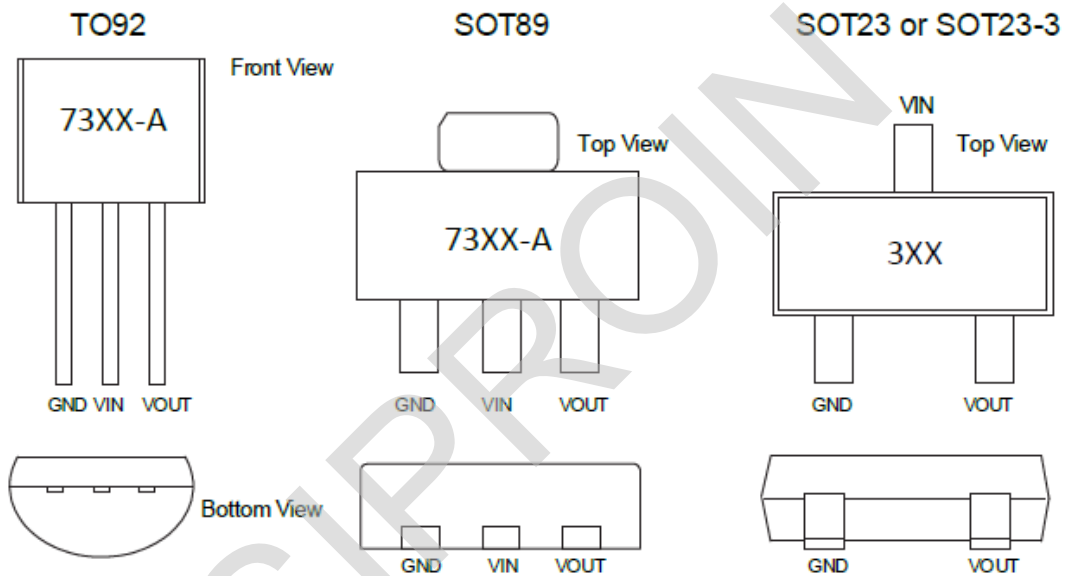

Absolute Maximum Ratings

Supply Voltage .....-0.3V to 18V      Storage Temperature .....-50°C to 125°C  
Operating Temperature .....-30°C to 85°C

Note: These are stress ratings only. Stresses exceeding the range specified under “Absolute Maximum Ratings” may cause substantial damage to the device. Functional operation of this device at other conditions beyond those listed in the specification is not implied and prolonged exposure to extreme conditions may affect device reliability.

Thermal Information

Symbol	Parameter	Package	Max.	Unit
$\theta_{JA}$	Thermal Resistance (Junction to Ambient) (Assume no ambient airflow, no heat sink)	SOT23	500	°C/W
		SOT89	200	°C/W
		TO92	200	°C/W
$P_D$	Power Dissipation	SOT23	0.20	W
		SOT89	0.50	W
		TO92	0.50	W

Note:  $P_D$  is measured at  $T_a = 25^\circ\text{C}$

### Electrical Characteristics

#### H7325-A, +2.5V Output Type

Symbol	Parameter	Test Conditions		Min.	Typ.	Max.	Unit
		V <sub>IN</sub>	Conditions				
V <sub>OUT</sub>	Output Voltage	4.5V	I <sub>OUT</sub> =40mA	2.450	2.500	2.550	V
I <sub>OUT</sub>	Output Current	4.5V	-	-	250	-	mA
ΔV <sub>OUT</sub>	Load Regulation	4.5V	1mA ≤ I <sub>OUT</sub> ≤ 60mA	-	45	90	mV
V <sub>DIF</sub>	Voltage Drop(Note)	-	I <sub>OUT</sub> =40mA, ΔV <sub>OUT</sub> =2%	-	100	-	mV
ISS	Current Consumption	4.5V	No load	-	2.0	3.0	μA
$\frac{\Delta V_{OUT}}{\Delta V_{IN} \times V_{OUT}}$	Line Regulation	-	3.5V ≤ V <sub>IN</sub> ≤ 12V I <sub>OUT</sub> =40mA	-	0.2	-	%/V
V <sub>IN</sub>	Input Voltage	-	-	-	-	15	V
$\frac{\Delta V_{OUT}}{\Delta T_a}$	Temperature Coefficient	4.5V	I <sub>OUT</sub> =40mA -40°C < T <sub>a</sub> < 85°C	-	±0.5	-	mV/°C

Note: Dropout voltage is defined as the input voltage minus the output voltage that produces a 2% change in the output voltage from the value at V<sub>IN</sub> = V<sub>OUT</sub>+1V with a fixed load.

#### H7328-A, +2.8V Output Type

Symbol	Parameter	Test Conditions		Min.	Typ.	Max.	Unit
		V <sub>IN</sub>	Conditions				
V <sub>OUT</sub>	Output Voltage	4.8V	I <sub>OUT</sub> =10mA	2.744	2.800	2.856	V
I <sub>OUT</sub>	Output Current	4.8V	-	-	250	-	mA
ΔV <sub>OUT</sub>	Load Regulation	4.8V	1mA ≤ I <sub>OUT</sub> ≤ 60mA	-	45	90	mV
V <sub>DIF</sub>	Voltage Drop(Note)	-	I <sub>OUT</sub> =40mA, ΔV <sub>OUT</sub> =2%	-	100	-	mV
ISS	Current Consumption	4.8V	No load	-	2.0	3.0	μA
$\frac{\Delta V_{OUT}}{\Delta V_{IN} \times V_{OUT}}$	Line Regulation	-	3.8V ≤ V <sub>IN</sub> ≤ 12V I <sub>OUT</sub> =40mA	-	0.2	-	%/V
V <sub>IN</sub>	Input Voltage	-	-	-	-	15	V
$\frac{\Delta V_{OUT}}{\Delta T_a}$	Temperature Coefficient	4.8V	I <sub>OUT</sub> =10mA -40°C < T <sub>a</sub> < 85°C	-	±0.5	-	mV/°C

Note: Dropout voltage is defined as the input voltage minus the output voltage that produces a 2% change in the output voltage from the value at V<sub>IN</sub> = V<sub>OUT</sub>+1V with a fixed load.

### H7330-A, +3.0V Output Type

Symbol	Parameter	Test Conditions		Min.	Typ.	Max.	Unit
		V <sub>IN</sub>	Conditions				
V <sub>OUT</sub>	Output Voltage	5V	I <sub>OUT</sub> =40mA	2.940	3.000	3.060	V
I <sub>OUT</sub>	Output Current	5V	-	-	250	-	mA
ΔV <sub>OUT</sub>	Load Regulation	5V	1mA ≤ I <sub>OUT</sub> ≤ 80mA	-	45	90	mV
V <sub>DIF</sub>	Voltage Drop(Note)	-	I <sub>OUT</sub> =40mA, ΔV <sub>OUT</sub> =2%	-	100	-	mV
ISS	Current Consumption	5V	No load	-	2.0	3.0	μA
$\frac{\Delta V_{OUT}}{\Delta V_{IN} \times V_{OUT}}$	Line Regulation	-	4V ≤ V <sub>IN</sub> ≤ 12V I <sub>OUT</sub> =40mA	-	0.2	-	%/V
V <sub>IN</sub>	Input Voltage	-	-	-	-	15	V
$\frac{\Delta V_{OUT}}{\Delta T_a}$	Temperature Coefficient	5V	I <sub>OUT</sub> =40mA -40°C < T <sub>a</sub> < 85°C	-	±0.5	-	mV/°C

Note: Dropout voltage is defined as the input voltage minus the output voltage that produces a 2% change in the output voltage from the value at V<sub>IN</sub> = V<sub>OUT</sub>+1V with a fixed load.

### H7333-A, +3.3V Output Type

Symbol	Parameter	Test Conditions		Min.	Typ.	Max.	Unit
		V <sub>IN</sub>	Conditions				
V <sub>OUT</sub>	Output Voltage	5.3V	I <sub>OUT</sub> =40mA	3.234	3.300	3.366	V
I <sub>OUT</sub>	Output Current	5.3V	-	-	250	-	mA
ΔV <sub>OUT</sub>	Load Regulation	5.3V	1mA ≤ I <sub>OUT</sub> ≤ 80mA	-	45	90	mV
V <sub>DIF</sub>	Voltage Drop(Note)	-	I <sub>OUT</sub> =40mA, ΔV <sub>OUT</sub> =2%	-	100	-	mV
ISS	Current Consumption	5.3V	No load	-	2.0	3	μA
$\frac{\Delta V_{OUT}}{\Delta V_{IN} \times V_{OUT}}$	Line Regulation	-	4.3V ≤ V <sub>IN</sub> ≤ 12V I <sub>OUT</sub> =40mA	-	0.2	-	%/V
V <sub>IN</sub>	Input Voltage	-	-	-	-	15	V
$\frac{\Delta V_{OUT}}{\Delta T_a}$	Temperature Coefficient	5.3V	I <sub>OUT</sub> =40mA -40°C < T <sub>a</sub> < 85°C	-	±0.5	-	mV/°C

Note: Dropout voltage is defined as the input voltage minus the output voltage that produces a 2% change in the output voltage from the value at V<sub>IN</sub> = V<sub>OUT</sub>+1V with a fixed load.

### H7336-A, +3.6V Output Type

Symbol	Parameter	Test Conditions		Min.	Typ.	Max.	Unit
		V <sub>IN</sub>	Conditions				
V <sub>OUT</sub>	Output Voltage	5.6V	I <sub>OUT</sub> =40mA	3.528	3.600	3.672	V
I <sub>OUT</sub>	Output Current	5.6V	-	-	250	-	mA
ΔV <sub>OUT</sub>	Load Regulation	5.6V	1mA ≤ I <sub>OUT</sub> ≤ 80mA	-	45	90	mV
V <sub>DIF</sub>	Voltage Drop(Note)	-	I <sub>OUT</sub> =40mA, ΔV <sub>OUT</sub> =2%	-	80	-	mV
ISS	Current Consumption	5.6V	No load	-	2.0	3.0	μA
$\frac{\Delta V_{OUT}}{\Delta V_{IN} \times V_{OUT}}$	Line Regulation	-	4.6V ≤ V <sub>IN</sub> ≤ 12V I <sub>OUT</sub> =40mA	-	0.2	-	%/V
V <sub>IN</sub>	Input Voltage	-	-	-	-	15	V
$\frac{\Delta V_{OUT}}{\Delta T_a}$	Temperature Coefficient	5.6V	I <sub>OUT</sub> =40mA -40°C < T <sub>a</sub> < 85°C	-	±0.5	-	mV/°C

Note: Dropout voltage is defined as the input voltage minus the output voltage that produces a 2% change in the output voltage from the value at V<sub>IN</sub> = V<sub>OUT</sub>+1V with a fixed load.

### H7340-A, +4.0V Output Type

Symbol	Parameter	Test Conditions		Min.	Typ.	Max.	Unit
		V <sub>IN</sub>	Conditions				
V <sub>OUT</sub>	Output Voltage	6.0V	I <sub>OUT</sub> =40mA	3.920	4.000	4.080	V
I <sub>OUT</sub>	Output Current	6.0V	-	-	250	-	mA
ΔV <sub>OUT</sub>	Load Regulation	6.0V	1mA ≤ I <sub>OUT</sub> ≤ 80mA	-	45	90	mV
V <sub>DIF</sub>	Voltage Drop(Note)	-	I <sub>OUT</sub> =40mA, ΔV <sub>OUT</sub> =2%	-	80	-	mV
ISS	Current Consumption	6.0V	No load	-	2.0	3.0	μA
$\frac{\Delta V_{OUT}}{\Delta V_{IN} \times V_{OUT}}$	Line Regulation	-	5V ≤ V <sub>IN</sub> ≤ 12V I <sub>OUT</sub> =40mA	-	0.2	-	%/V
V <sub>IN</sub>	Input Voltage	-	-	-	-	15	V
$\frac{\Delta V_{OUT}}{\Delta T_a}$	Temperature Coefficient	6.0V	I <sub>OUT</sub> =40mA -40°C < T <sub>a</sub> < 85°C	-	±0.5	-	mV/°C

Note: Dropout voltage is defined as the input voltage minus the output voltage that produces a 2% change in the output voltage from the value at V<sub>IN</sub> = V<sub>OUT</sub>+1V with a fixed load.

### H7344-A, +4.4V Output Type

Symbol	Parameter	Test Conditions		Min.	Typ.	Max.	Unit
		V <sub>IN</sub>	Conditions				
V <sub>OUT</sub>	Output Voltage	6.4V	I <sub>OUT</sub> =40mA	4.312	4.400	4.488	V
I <sub>OUT</sub>	Output Current	6.4V	-	-	250	-	mA
ΔV <sub>OUT</sub>	Load Regulation	6.4V	1mA ≤ I <sub>OUT</sub> ≤ 80mA	-	45	90	mV
V <sub>DIF</sub>	Voltage Drop(Note)	-	I <sub>OUT</sub> =40mA, ΔV <sub>OUT</sub> =2%	-	80	-	mV
ISS	Current Consumption	6.4V	No load	-	2.0	3.0	μA
$\frac{\Delta V_{OUT}}{\Delta V_{IN} \times V_{OUT}}$	Line Regulation	-	5.4V ≤ V <sub>IN</sub> ≤ 12V I <sub>OUT</sub> =40mA	-	0.2	-	%V
V <sub>IN</sub>	Input Voltage	-	-	-	-	15	V
$\frac{\Delta V_{OUT}}{\Delta T_a}$	Temperature Coefficient	6.4V	I <sub>OUT</sub> =40mA -40°C < T <sub>a</sub> < 85°C	-	±0.5	-	mV/°C

Note: Dropout voltage is defined as the input voltage minus the output voltage that produces a 2% change in the output voltage from the value at V<sub>IN</sub> = V<sub>OUT</sub>+1V with a fixed load.

### H7350-A, +5.0V Output Type

Symbol	Parameter	Test Conditions		Min.	Typ.	Max.	Unit
		V <sub>IN</sub>	Conditions				
V <sub>OUT</sub>	Output Voltage	7V	I <sub>OUT</sub> =40mA	4.900	5.000	5.100	V
I <sub>OUT</sub>	Output Current	7V	-	-	250	-	mA
ΔV <sub>OUT</sub>	Load Regulation	7V	1mA ≤ I <sub>OUT</sub> ≤ 80mA	-	45	90	mV
V <sub>DIF</sub>	Voltage Drop(Note)	-	I <sub>OUT</sub> =40mA, ΔV <sub>OUT</sub> =2%	-	80	-	mV
ISS	Current Consumption	7V	No load	-	2.0	3.0	μA
$\frac{\Delta V_{OUT}}{\Delta V_{IN} \times V_{OUT}}$	Line Regulation	-	6V ≤ V <sub>IN</sub> ≤ 12V I <sub>OUT</sub> =40mA	-	0.2	-	%V
V <sub>IN</sub>	Input Voltage	-	-	-	-	15	V
$\frac{\Delta V_{OUT}}{\Delta T_a}$	Temperature Coefficient	7V	I <sub>OUT</sub> =40mA -40°C < T <sub>a</sub> < 85°C	-	±0.5	-	mV/°C

Note: Dropout voltage is defined as the input voltage minus the output voltage that produces a 2% change in the output voltage from the value at V<sub>IN</sub> = V<sub>OUT</sub>+1V with a fixed load.

### Typical Performance Characteristics

#### (1) Output Voltage vs Input voltage

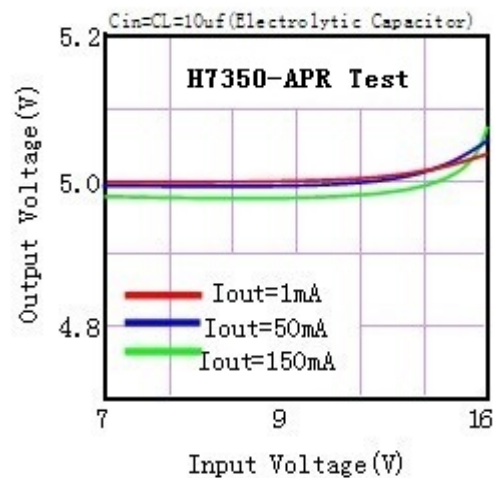
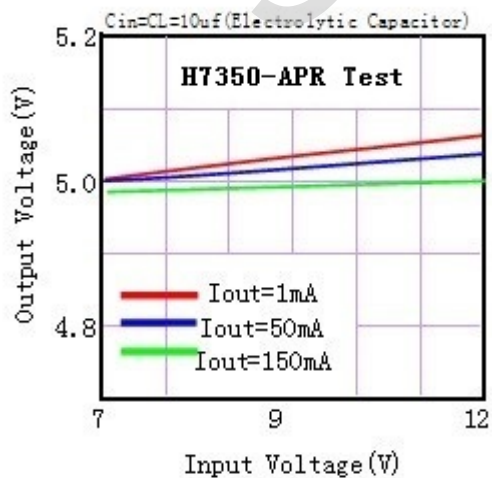
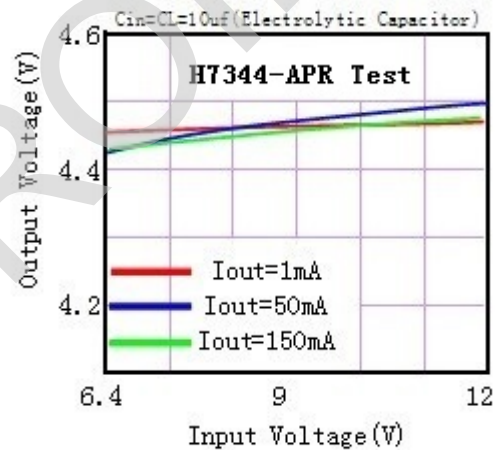
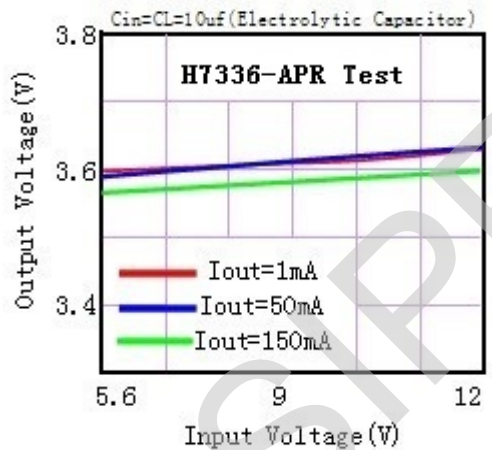
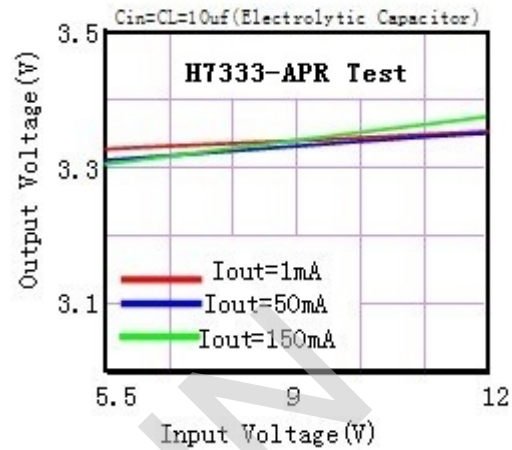
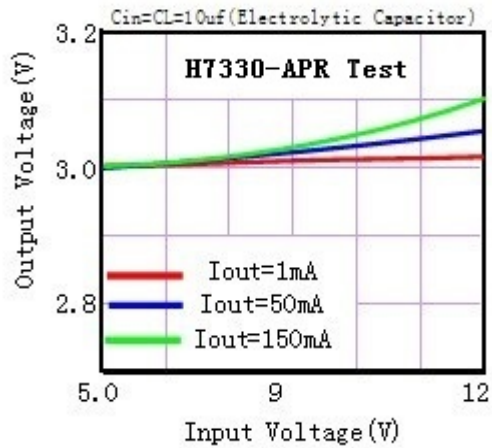

(2) Output Voltage vs. Output Current

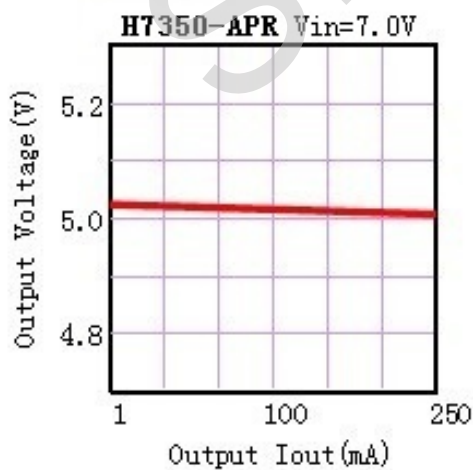
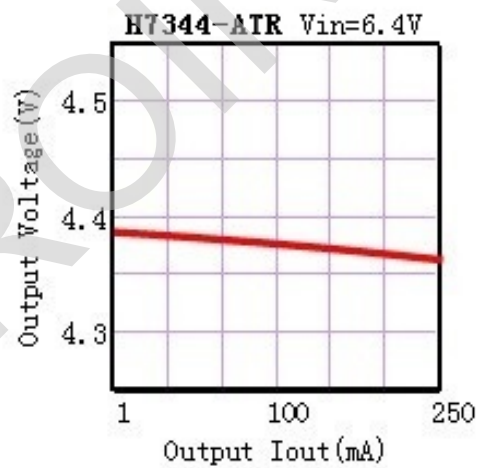
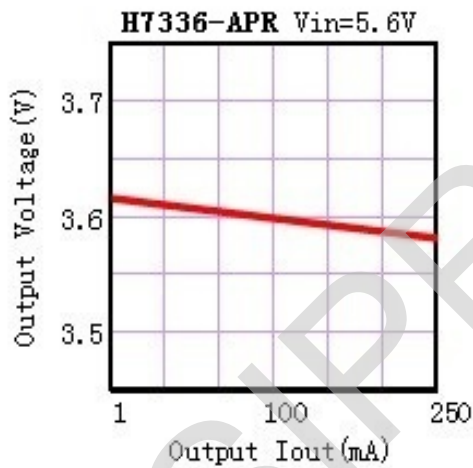
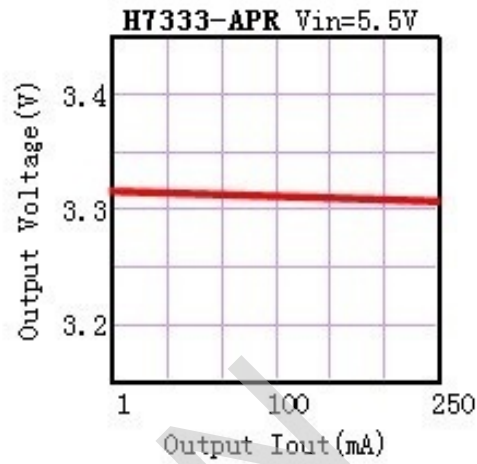
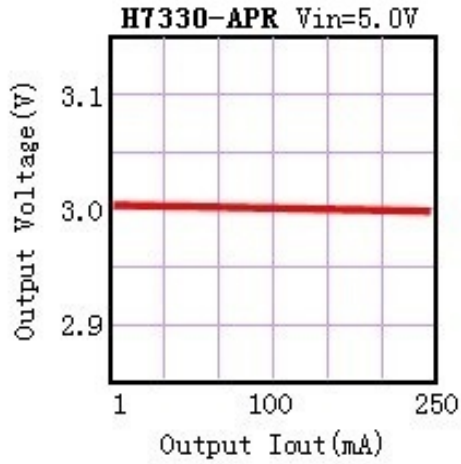



(3) Input Transient Response

H7330-ATR Iout=10mA CL=10uF

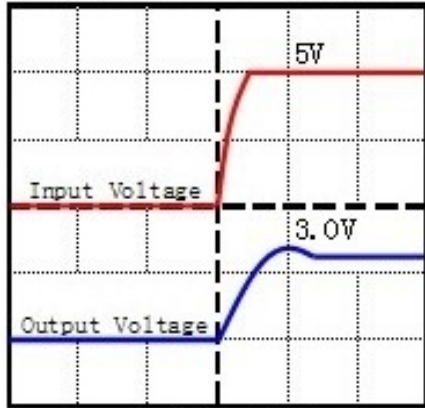

Time (5ms/div)

H7333-ATR Iout=10mA CL=10uF

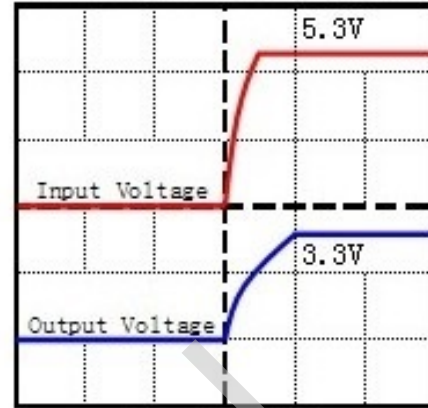

Time (5ms/div)

H7344-ATR Iout=10mA CL=10uF

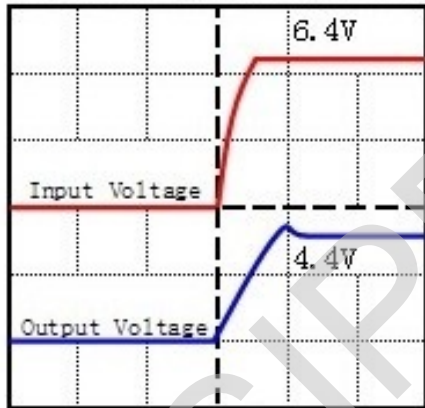

Time (5ms/div)

H7350-APR Iout=10mA CL=10uF

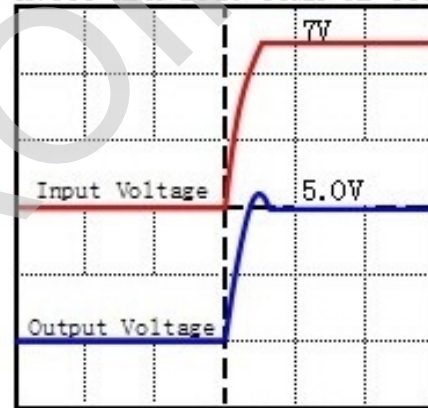

Time (5ms/div)

(4) Output Voltage vs. Ambient Temperature

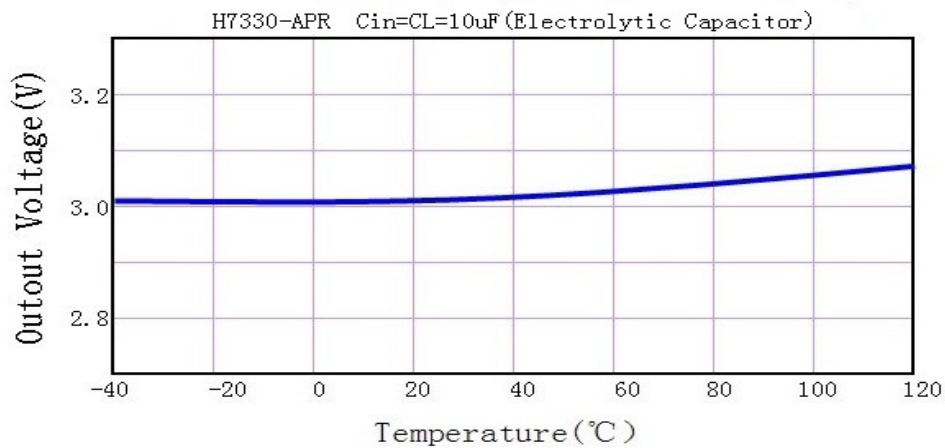

(5) MAX Output Current Vs. Input Voltage

H7330-APR

Input Voltage	Max Output Current
5V	250mA
9V	200mA
12V	150mA
15V	100mA

H7333-APR

Input Voltage	Max Output Current
5.3V	250mA
9V	200mA
12V	150mA
15V	100mA

H7350-APR

Input Voltage	Max Output Current
7V	250mA
9V	200mA
12V	150mA
15V	100mA

### Application Circuits

#### Basic Circuits

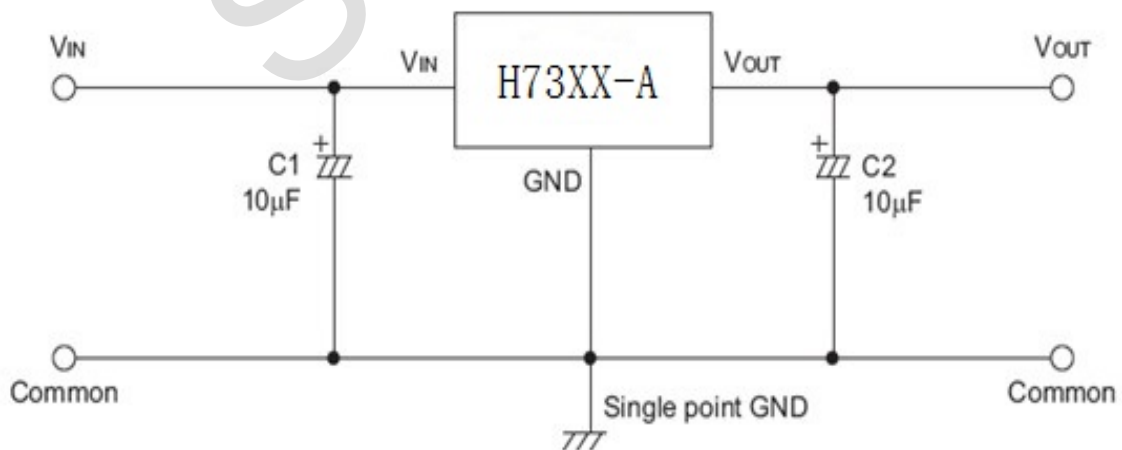

Package Information  
3-pin TO92 Outline Dimensions

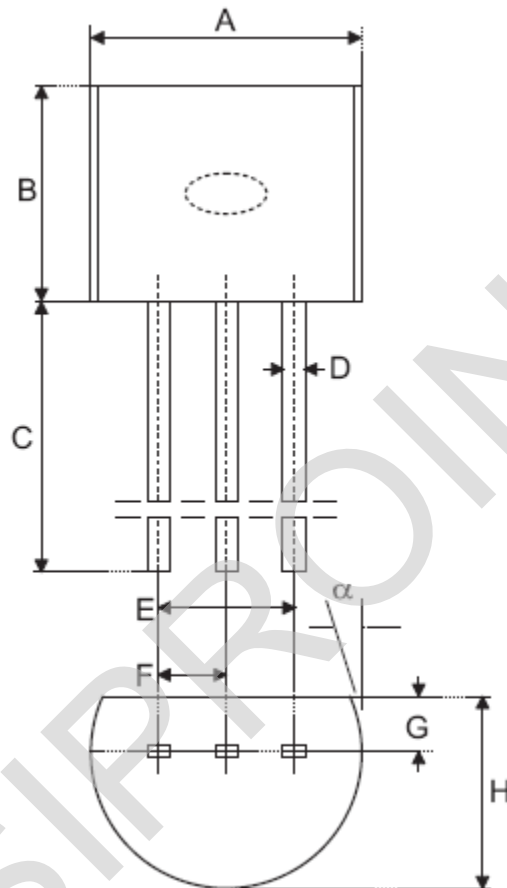

Symbol	Dimensions in mil		
	Min.	Nom.	Max.
A	170	—	200
B	170	—	200
C	500	—	—
D	11	—	20
E	90	—	110
F	45	—	55
G	45	—	65
H	130	—	160
I	8	—	18
$\alpha$	4°	—	6°

3-pin SOT89 Outline Dimensions

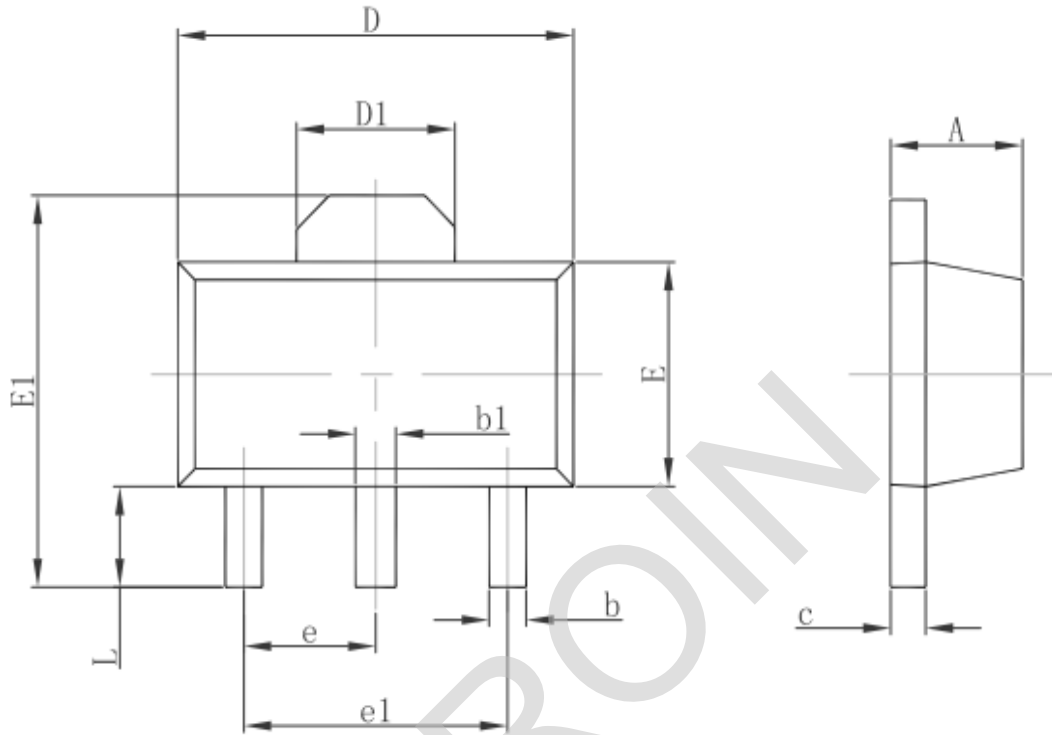

Symbol	Dimensions In Millimeters		Dimensions In Inches	
	Min.	Max.	Min.	Max.
A	1.400	1.600	0.055	0.063
b	0.320	0.520	0.013	0.020
b1	0.400	0.580	0.016	0.023
c	0.350	0.440	0.014	0.017
D	4.400	4.600	0.173	0.181
D1	1.550 REF.		0.061 REF.	
E	2.300	2.600	0.091	0.102
E1	3.940	4.250	0.155	0.167
e	1.500 TYP.		0.060 TYP.	
e1	3.000 TYP.		0.118 TYP.	
L	0.900	1.200	0.035	0.047

3-pin SOT23 Outline Dimensions

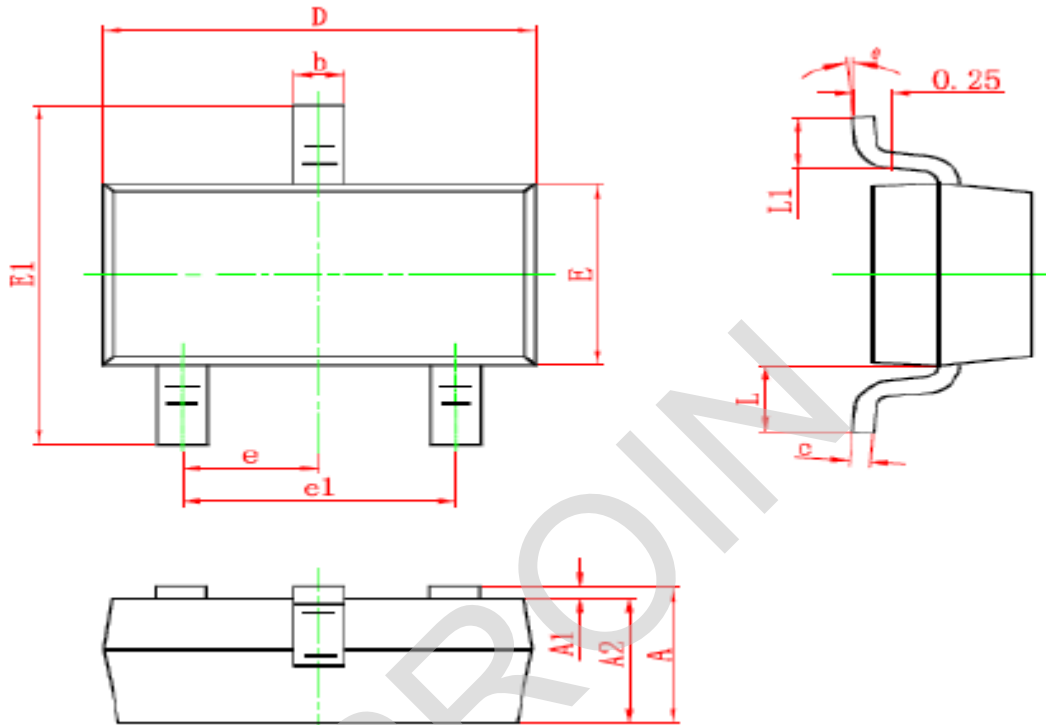

Symbol	Dimensions in Millimeters		Dimensions in Inches	
	Min	Max	Min	Max
A	0.900	1.150	0.035	0.045
A1	0.000	0.100	0.000	0.004
A2	0.900	1.050	0.035	0.041
b	0.300	0.500	0.012	0.020
c	0.080	0.150	0.003	0.006
D	2.800	3.000	0.110	0.118
E	1.200	1.400	0.047	0.055
E1	2.250	2.550	0.089	0.100
e	0.950 TYP		0.037 TYP	
e1	1.800	2.000	0.071	0.079
L	0.550 REF		0.022 REF	
L1	0.300	0.500	0.012	0.020
$\theta$	0°	8°	0°	6°

3-pin SOT23-3 Outline Dimensions

SOT-23-3L PACKAGE OUTLINE DIMENSIONS

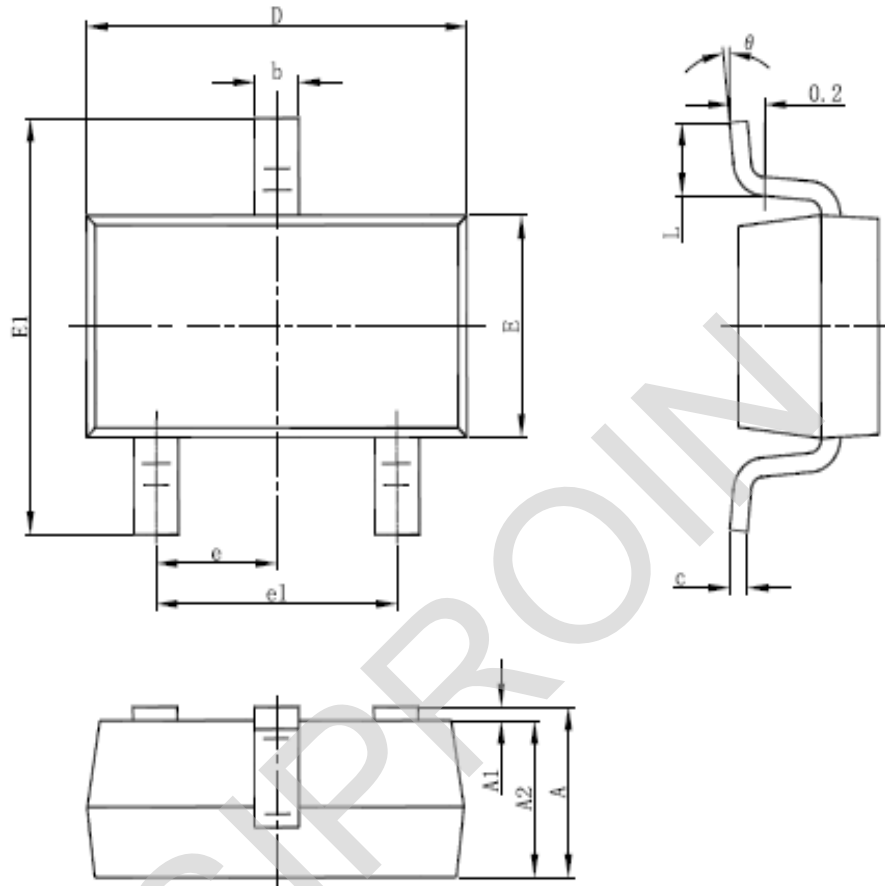

Symbol	Dimensions In Millimeters		Dimensions In Inches	
	Min	Max	Min	Max
A	1.050	1.250	0.041	0.049
A1	0.000	0.100	0.000	0.004
A2	1.050	1.150	0.041	0.045
b	0.300	0.500	0.012	0.020
c	0.100	0.200	0.004	0.008
D	2.820	3.020	0.111	0.119
E	1.500	1.700	0.059	0.067
E1	2.650	2.950	0.104	0.116
e	0.950(BSC)		0.037(BSC)	
e1	1.800	2.000	0.071	0.079
L	0.300	0.600	0.012	0.024
θ	0°	8°	0°	8°

## X-ON Electronics

Largest Supplier of Electrical and Electronic Components

*Click to view similar products for [LDO Voltage Regulators](#) category:*

*Click to view products by [Siproin](#) manufacturer:*

Other Similar products are found below :

[AP7363-SP-13](#) [L79M05TL-E](#) [AP7362-HA-7](#) [PT7M8202B12TA5EX](#) [TCR3DF185,LM\(CT](#) [TCR3DF45,LM\(CT](#) [TLE4473G V52](#) [059985X](#)  
[NCP4687DH15T1G](#) [701326R](#) [NCV8170AXV250T2G](#) [AP7315-25W5-7](#) [AP2111H-1.2TRG1](#) [ZLDO1117QK50TC](#) [AZ1117ID-ADJTRG1](#)  
[TCR3DG12,LF](#) [MIC5514-3.3YMT-T5](#) [SCD7912BTG](#) [NCP154MX180270TAG](#) [SCD33269T-5.0G](#) [NCV8170BXV330T2G](#)  
[NCV8170BMX330TCG](#) [NCV8170AMX120TCG](#) [NCP706ABMX300TAG](#) [NCP153MX330180TCG](#) [NCP114BMX075TCG](#) [MC33269T-3.5G](#)  
[CAT6243-ADJCMT5T](#) [TCR3DG33,LF](#) [TCR4DG35,LF](#) [TAR5S15U\(TE85L,F\)](#) [TAR5S18U\(TE85L,F\)](#) [TCR3UG19A,LF](#) [TCR4DG105,LF](#)  
[MPQ2013AGG-5-P](#) [NCV8170AMX360TCG](#) [TLE4268GSXUMA2](#) [NCP715SQ15T2G](#) [MIC5317-3.0YD5-T5](#) [NCV563SQ18T1G](#)  
[NCP715MX30TBG](#) [NCV8702MX25TCG](#) [NCV8170BXV120T2G](#) [MIC5317-1.2YD5-T5](#) [NCV8170AMX150TCG](#) [NCV8170BMX150TCG](#)  
[AP2213D-3.3TRG1](#) [NCV8170BMX120TCG](#) [NCV8170BMX310TCG](#) [NCV8170BMX360TCG](#)