

Features

- Low voltage drop: 0.06V@100mA
- High input voltage: 8V
- Low temperature coefficient
- Low Quiescent Current: 25uA at 5.0V
- Output voltage accuracy: tolerance $\pm 2\%$
- SOT89 ,SOT223 and SOT23-5 package

Applications

- Battery-powered equipment
- Hand-Hold Equipment
- GRS Receivers
- Wireless LAN

General Description

The H7650 series is a group of positive voltage output, three-pin regulators, that provide a high current even when the input/output voltage differential is small. Low power consumption and high accuracy is achieved through CMOS and laser trimming technologies.

The H7650 consists of a high-precision voltage reference, an error amplification circuit, and a current limited output driver. Transient response to load variations have improved in comparison to the existing series.

Order Information

H7650-①②③④

Designator	Symbol	Description
① ②	Integer	Output Voltage(1.2~5.0V)
③	P	Package:SOT89
	G	Package:SOT223
	M5	Package:SOT23-5
④	R	RoHS / Pb Free
	G	Halogen Free

Block Diagram

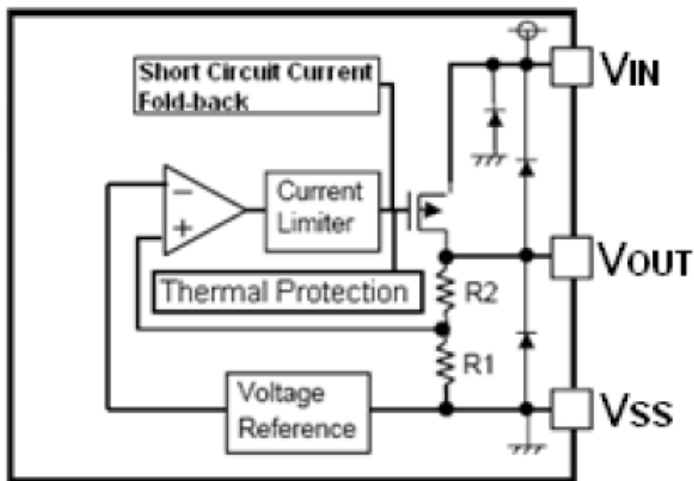

Pin Assignment

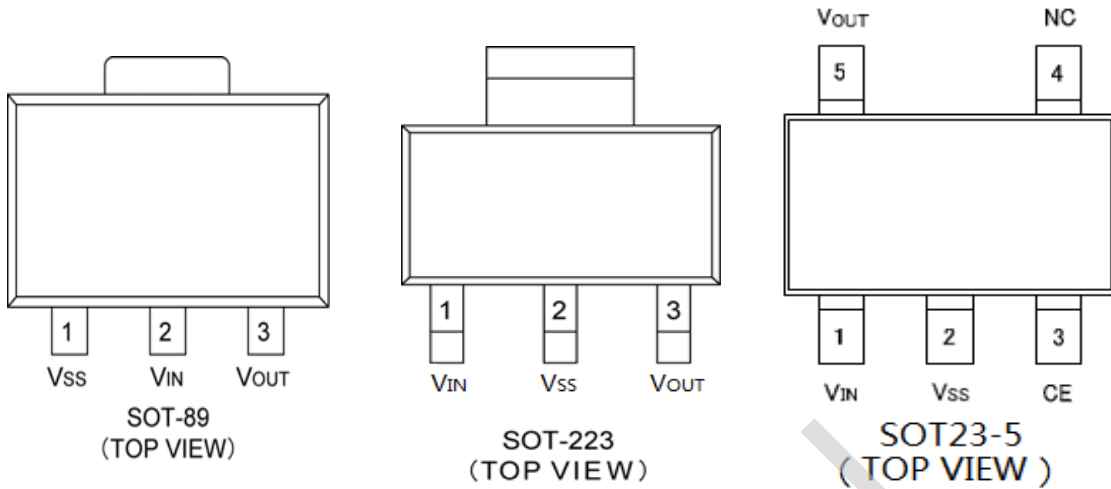

Absolute Maximum Ratings

Supply Voltage	-0.3V to 9V	Operating Temperature	-40°C to 85°C
Output Current.....	1.1A	Storage Temperature	-40°C to 125°C

Note: These are stress ratings only. Stresses exceeding the range specified under “Absolute Maximum Ratings” may cause substantial damage to the device. Functional operation of this device at other conditions beyond those listed in the specification is not implied and prolonged exposure to extreme conditions may affect device reliability.

Electrical Characteristics

H7650 for any output voltage

(Ta=25°C)

Symbol	Parameter	Conditions	Min.	Typ.	Max.	Unit
V _{OUT}	Output Voltage	V _{in} =V _{out} +1V 1.0mA≤I _{out} ≤30mA	V _{out} ×0.98	--	V _{out} ×1.02	V
I _{OUT}	Output Current*1	V _{in} -V _{out} =1V	--	750	--	mA
V _{DROP}	Low dropout*2	Refer to the next table				
$\frac{\Delta V_{OUT}}{\Delta V_{IN} \times V_{OUT}}$	Line Regulation	1.6V≤V _{in} ≤8V I _{out} =100mA	--	0.05	0.2	%/V
$\Delta V_{OUT} / \Delta I_{OUT}$	$\Delta V_{out} / \Delta I_{out}$	V _{in} = V _{out} +1V 1.0mA≤I _{out} ≤100mA	--	12	30	mV
Output voltage Temperature Coefficiency	$\Delta V_{out} / (T_a - V_{out})$	I _{out} =30mA 0°C≤T _a ≤70°C	--	±100	--	Ppm/°C
PSRR	PSRR	F=1KHz V _{in} =V _{out} +1V	--	70	--	dB
Supply Current	I _{ss1}	--	--	25	35	uA
Input Voltage	V _{in}	--	--	--	10	V
Thermal shutdown detection temperature	T _{SD}	Junction temperature	-	160	-	°C
Thermal shutdown release temperature	T _{SR}	Junction temperature	-	140	-	°C

Electrical Characteristics by Output Voltage:

Output Voltage V _{out} (V)	Dropout Voltage V _{dif} (V)		
	Conditions	Typ.	Max.
V _{out} ≤ 2.0V	I _{out} =60 mA	0.05	0.08
2.0 < V _{out} ≤ 3.0	I _{out} =80 mA	0.05	0.08
3.0 < V _{out} ≤ 4.0	I _{out} =100 mA	0.06	0.08
4.0 < V _{out} ≤ 5.0		0.05	0.08
3.0 < V _{out} ≤ 4.0	I _{out} =200 mA	0.13	0.16
4.0 < V _{out} ≤ 5.0		0.12	0.16
3.0 < V _{out} ≤ 4.0	I _{out} =1000 mA	0.65	0.8
4.0 < V _{out} ≤ 5.0		0.6	0.8

Application Circuits

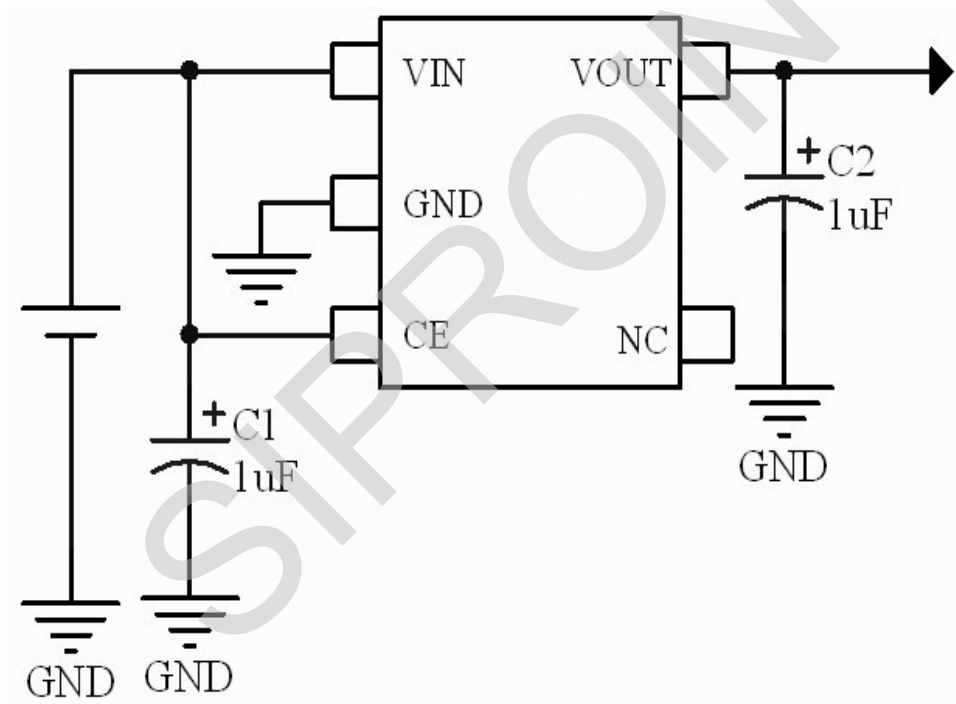
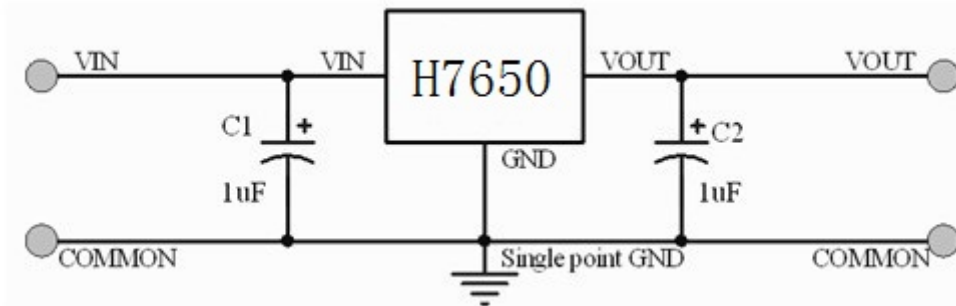

Note1: Input capacitor $C_{IN}=1\mu F$.

Note2: Output capacitor $C_{OUT}=1\mu F/6.8\mu F$ (1uF Tantalum capacitor or 6.8uF ceramic capacitor is recommended).

Package Information

SOT-89-3L PACKAGE OUTLINE DIMENSIONS

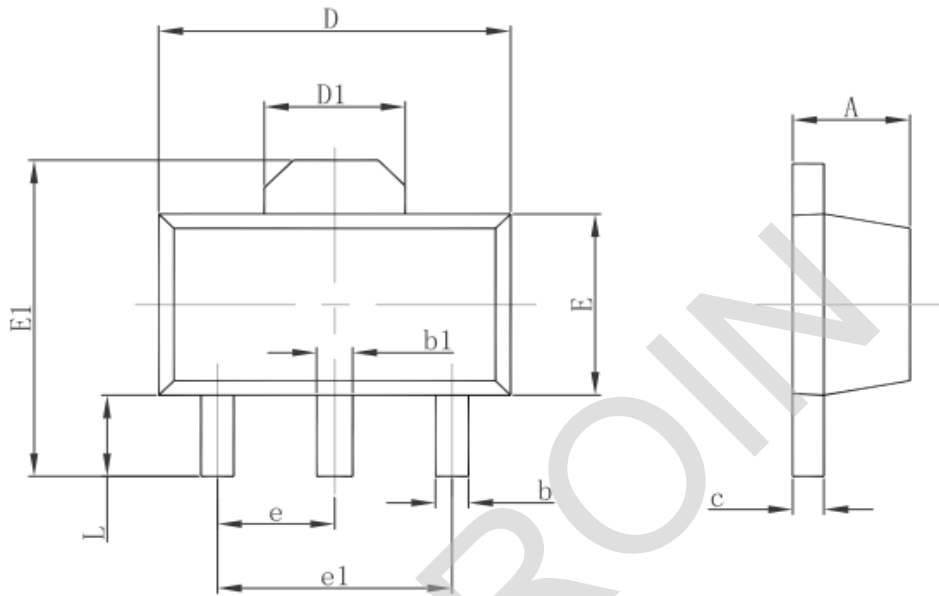

Symbol	Dimensions In Millimeters		Dimensions In Inches	
	Min.	Max.	Min.	Max.
A	1.400	1.600	0.055	0.063
b	0.320	0.520	0.013	0.020
b1	0.400	0.580	0.016	0.023
c	0.350	0.440	0.014	0.017
D	4.400	4.600	0.173	0.181
D1	1.550 REF.		0.061 REF.	
E	2.300	2.600	0.091	0.102
E1	3.940	4.250	0.155	0.167
e	1.500 TYP.		0.060 TYP.	
e1	3.000 TYP.		0.118 TYP.	
L	0.900	1.200	0.035	0.047

SOT-223 PACKAGE OUTLINE DIMENSIONS

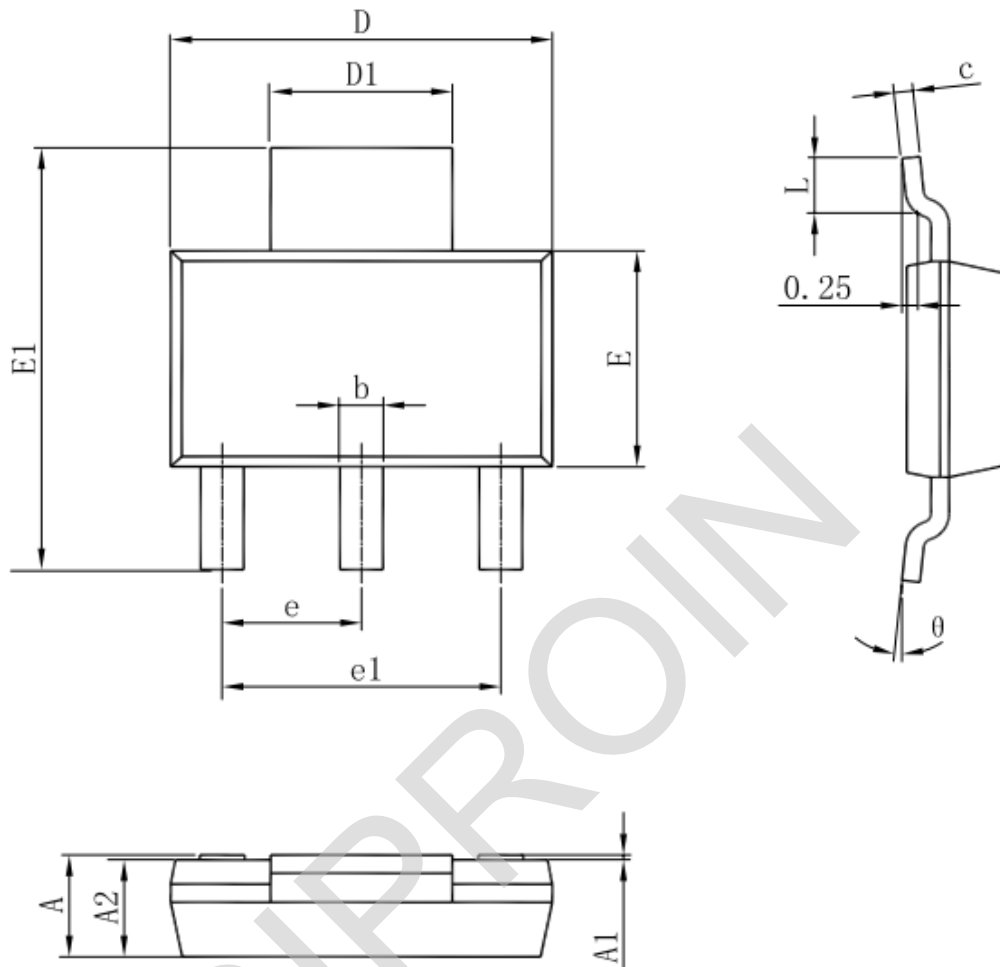

Symbol	Dimensions In Millimeters		Dimensions In Inches	
	Min	Max	Min	Max
A	1.520	1.800	0.060	0.071
A1	0.000	0.100	0.000	0.004
A2	1.500	1.700	0.059	0.067
b	0.660	0.820	0.026	0.032
c	0.250	0.350	0.010	0.014
D	6.200	6.400	0.244	0.252
D1	2.900	3.100	0.114	0.122
E	3.300	3.700	0.130	0.146
E1	6.830	7.070	0.269	0.278
e	2.300(BSC)		0.091(BSC)	
e1	4.500	4.700	0.177	0.185
L	0.900	1.150	0.035	0.045
θ	0°	10°	0°	10°

SOT-23-5L PACKAGE OUTLINE DIMENSIONS

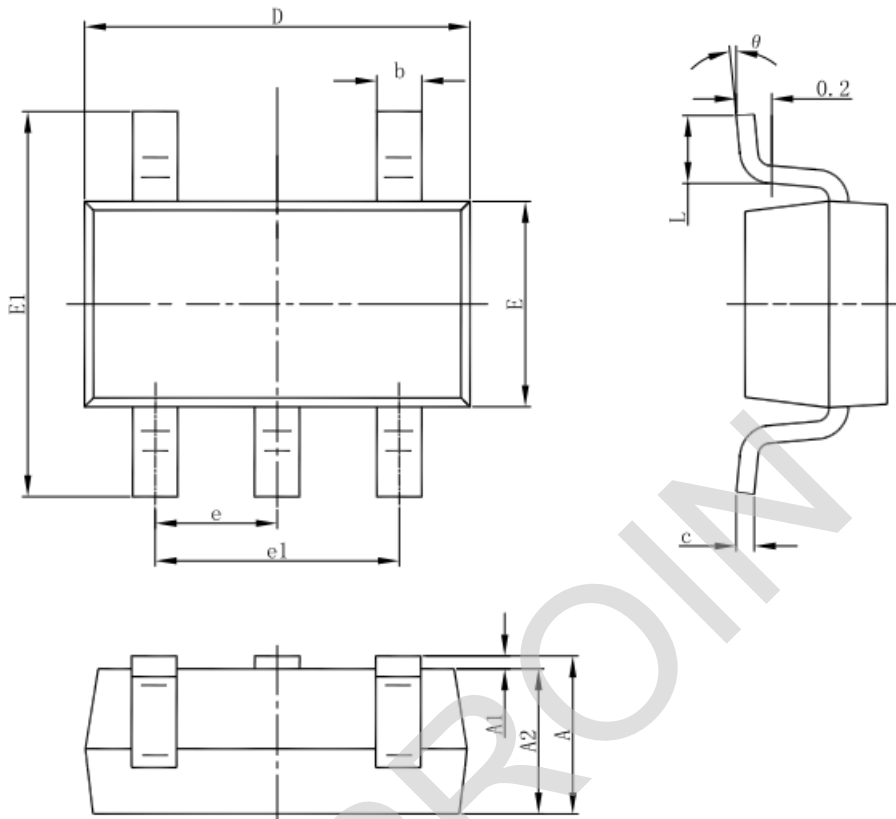

Symbol	Dimensions In Millimeters		Dimensions In Inches	
	Min	Max	Min	Max
A	1.050	1.250	0.041	0.049
A1	0.000	0.100	0.000	0.004
A2	1.050	1.150	0.041	0.045
b	0.300	0.500	0.012	0.020
c	0.100	0.200	0.004	0.008
D	2.820	3.020	0.111	0.119
E	1.500	1.700	0.059	0.067
E1	2.650	2.950	0.104	0.116
e	0.950(BSC)		0.037(BSC)	
e1	1.800	2.000	0.071	0.079
L	0.300	0.600	0.012	0.024
θ	0°	8°	0°	8°

X-ON Electronics

Largest Supplier of Electrical and Electronic Components

Click to view similar products for [LDO Voltage Regulators](#) category:

Click to view products by [Siproin](#) manufacturer:

Other Similar products are found below :

[M38D29FFHP#U1](#) [702103A](#) [717726C](#) [742457H](#) [MP20051DN-LF-Z](#) [R5F111PGGFB#30](#) [AP7363-SP-13](#) [NCP103AMX285TCG](#)
[NCV8664CST33T3G](#) [NCV8752AMX28TCG](#) [L9454](#) [AP7362-HA-7](#) [LX13043CLD](#) [TCR3DF185,LM\(CT](#) [TCR3DF24,LM\(CT](#)
[TCR3DF285,LM\(CT](#) [TCR3DF31,LM\(CT](#) [TCR3DF45,LM\(CT](#) [TLF4949EJ](#) [L9708](#) [L970813TR](#) [030014BB](#) [059985X](#) [EAN61387601](#)
[EAN61573601](#) [NCP121AMX173TCG](#) [NCP4687DH15T1G](#) [NCV8703MX30TCG](#) [701326R](#) [702087BB](#) [755078E](#) [TCR2EN28,LF\(S](#)
[LM1117DT-1.8/NO](#) [LT1086CM#TRPBF](#) [AZ1085S2-1.5TRE1](#) [MAX15101EWL+T](#) [NCV8170AXV250T2G](#) [SCD337BTG](#)
[TCR3DF27,LM\(CT](#) [TCR3DF19,LM\(CT](#) [TCR3DF125,LM\(CT](#) [TCR2EN18,LF\(S](#) [MAX15103EWL+T](#) [TS2937CZ-5.0 C0](#) [MAX8878EUK30-](#)
[T](#) [MAX663CPA](#) [NCV4269CPD50R2G](#) [NCV8716MT30TBG](#) [AZ1117IH-1.2TRG1](#) [MP2013GQ-P](#)