

### Features

- Low power consumption
- Low temperature coefficient
- Built-in hysteresis characteristic
- High input voltage (up to 8V)
- Output voltage accuracy: tolerance  $\pm 1\%$  or  $\pm 2\%$
- SOT23-3 and SOT23 package

### Applications

- Battery checkers
- Level selectors
- Power failure detectors
- Microcomputer reset
- Battery memory backup
- Non-volatile RAM signal storage protectors

### General Description

The SSP61C series devices are a set of three terminal low power voltage detectors implemented in CMOS technology. Each voltage detector in the series detects a particular fixed voltage ranging from 0.9V to 5.0V. The voltage detectors consist of a high-precision and low power consumption standard voltage source as well as a comparator,

hysteresis circuit, and an output driver (CMOS inverter or NMOS open drain). CMOS technology ensures low power consumption.

Although designed primarily as fixed voltage detectors, these devices can be used with external components to detect user specified threshold voltages.

### Selection Table

Part No.	Det. Voltage	Hys. Width	Output	Tolerance	Package
SSP61CC0902MR	0.9V	4%	CMOS	$\pm 1\%$ or $\pm 2\%$	SOT23-3 SOT23
SSP61CN0902MR	0.9V	4%	NMOS	$\pm 1\%$ or $\pm 2\%$	
SSP61CC1002MR	1.0V	4%	CMOS	$\pm 1\%$ or $\pm 2\%$	
SSP61CN1002MR	1.0V	4%	NMOS	$\pm 1\%$ or $\pm 2\%$	
SSP61CC1102MR	1.1V	4%	CMOS	$\pm 1\%$ or $\pm 2\%$	
SSP61CN1102MR	1.1V	4%	NMOS	$\pm 1\%$ or $\pm 2\%$	
SSP61CC1202MR	1.2V	4%	CMOS	$\pm 1\%$ or $\pm 2\%$	
SSP61CN1202MR	1.2V	4%	NMOS	$\pm 1\%$ or $\pm 2\%$	
...	...	4%	...	$\pm 1\%$ or $\pm 2\%$	
SSP61CC5002MR	5.0V	4%	CMOS	$\pm 1\%$ or $\pm 2\%$	
SSP61CN5002MR	5.0V	4%	NMOS	$\pm 1\%$ or $\pm 2\%$	

### Order Information

SSP61C①②③④⑤⑥⑦

Designator	Symbol	Description
①	C	CMOS output
	N	NMOS output
②③	VOUT	Output Voltage(0.9~5.0V)
④⑤	02	±2% accuracy
	01	±1% accuracy
⑥	M	Package:SOT23-3
	N	Package:SOT23
⑦	R	RoHS / Pb Free
	G	Halogen Free

### Block Diagram

(1) CMOS Output

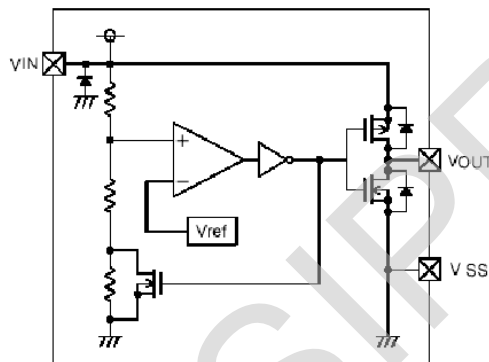

(2) N-ch Open Drain Output

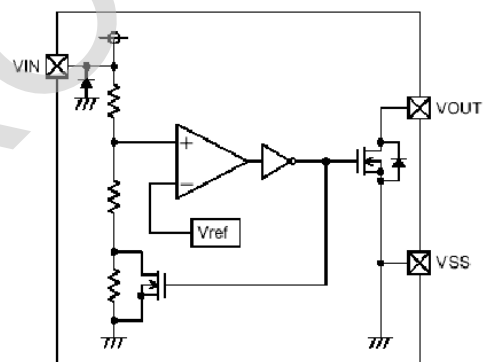

### Typical Application Circuits

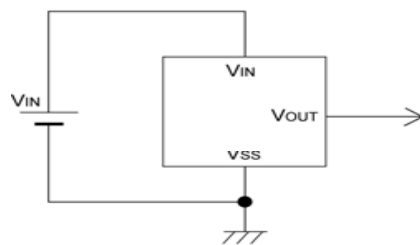

CMOS Output

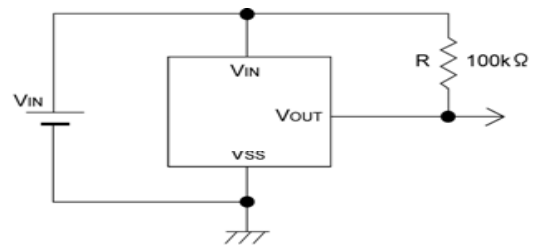

N-ch Open Drain Output

### Output Table & Curve

$V_{DD}$	$V_{DD} > V_{DET}(+)$	$V_{DD} \leq V_{DET}(-)$
$V_{OUT}$	Hi-Z	$V_{SS}$

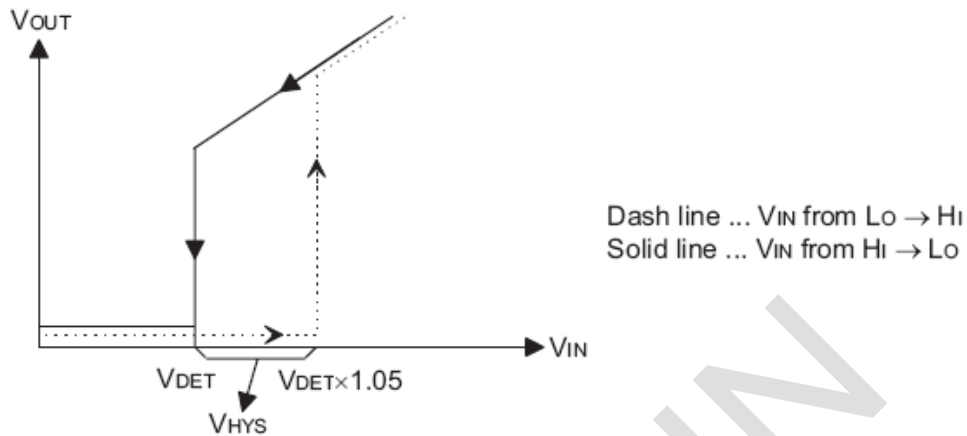

### Pin Assignment

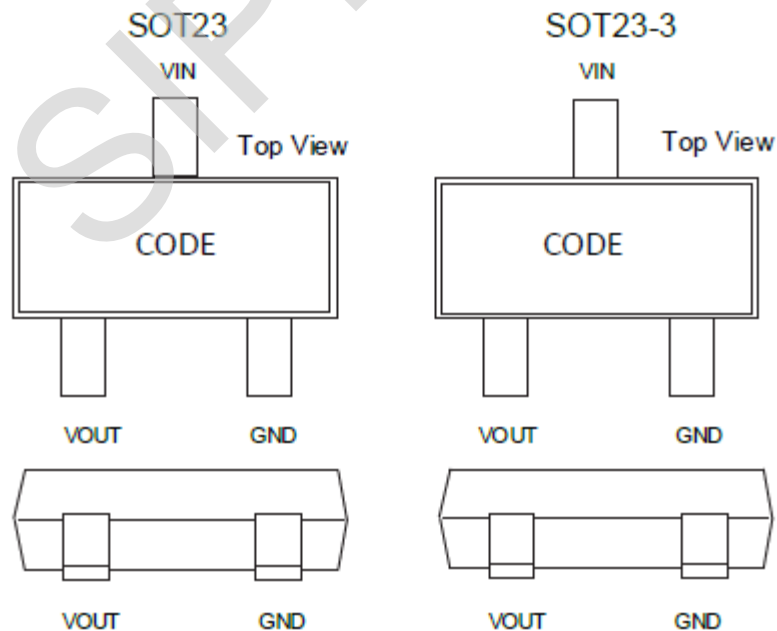

### Marking Rule



① Represents integer of detect voltage and CMOS Output

MARK	CONFIGURATION	VOLTAGE (V)
A	CMOS	0.X
B	CMOS	1.X
C	CMOS	2.X
D	CMOS	3.X
E	CMOS	4.X
F	CMOS	5.X
H	CMOS	6.X

N-Channel Open Drain Output

MARK	CONFIGURATION	VOLTAGE (V)
K	N-ch	0.X
L	N-ch	1.X
M	N-ch	2.X
N	N-ch	3.X
P	N-ch	4.X
R	N-ch	5.X
S	N-ch	6.X

② Represents decimal number of detect voltage

MARK	VOLTAGE (V)	MARK	VOLTAGE (V)
0	X.0	5	X.5
1	X.1	6	X.6
2	X.2	7	X.7
3	X.3	8	X.8
4	X.4	9	X.9

③ Represents accuracy

MARK	ACCURACY
3	2%
1	1%

④ Represents production lot number

Based on the internal standard. (G, I, J, O, Q, W excepted)

### Absolute Maximum Ratings

Supply Voltage .....-0.3V to 8V      Storage Temperature .....-50°C to 125°C  
 Operating Temperature .....-40°C to 85°C

Note: These are stress ratings only. Stresses exceeding the range specified under “Absolute Maximum Ratings” may cause substantial damage to the device. Functional operation of this device at other conditions beyond those listed in the specification is not implied and prolonged exposure to extreme conditions may affect device reliability.

### Thermal Information

Symbol	Parameter	Package	Max.	Unit
$\theta_{JA}$	Thermal Resistance (Junction to Ambient) (Assume no ambient airflow, no heat sink)	SOT23-3	500	°C/W
$P_D$	Power Dissipation	SOT23-3	0.20	W

Note:  $P_D$  is measured at  $T_a = 25^\circ\text{C}$

### Electrical Characteristics

$V_{DF} = 0.8\text{V} \sim 5.0\text{V}$

$T_a = 25^\circ\text{C}$

Symbol	Parameter	Test Conditions		Min.	Typ.	Max.	Unit
$V_{DET}$	Detection Voltage	$V_{DF} = 0.8\text{V} \sim 5.0\text{V}$		$V_{DF} * 0.98$	$V_{DF}$	$V_{DF} * 1.02$	V
$V_{HYS}$	Hysteresis Width	-		$0.02 * V_{DET}$	$0.05 * V_{DET}$	$0.10 * V_{DET}$	V
$I_{DD}$	Operating Current	$V_{in} = 1.5\text{V}$		-	0.7	2.3	$\mu\text{A}$
		$V_{in} = 2.0\text{V}$		-	0.8	2.7	
		$V_{in} = 3.0\text{V}$		-	0.9	3.0	
		$V_{in} = 4.0\text{V}$		-	1.0	3.2	
		$V_{in} = 5.0\text{V}$		-	1.1	3.6	
$V_{DD}$	Operating Voltage	-	-	0.7	-	10	V
$I_{OL}$	Output Sink Current	2V	$V_{OUT} = 0.2\text{V}$	0.5	1	-	mA
$\frac{\Delta V_{DET}}{V_{DF} \Delta T_a}$	Temperature Coefficient	-	-25°C < $T_a$ >125°C	-	$\pm 100$	-	ppm/°C

## Typical Performance Characteristics

### (1) Output Voltage vs Input voltage

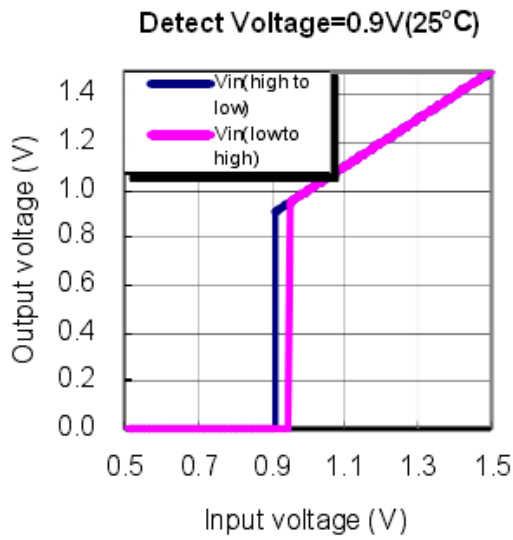

### (2) Supply Current vs. Input Voltage

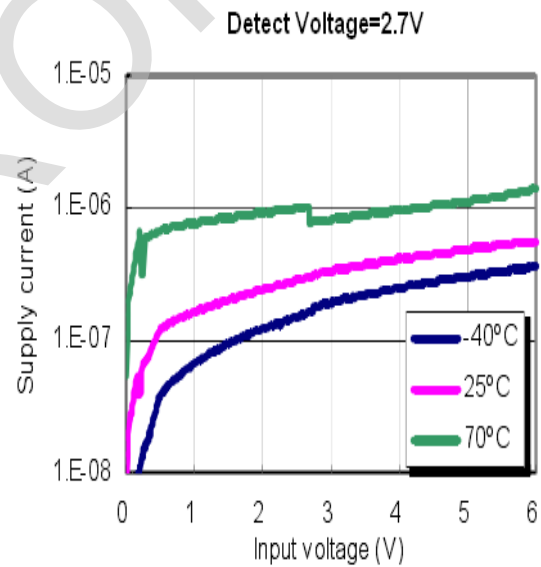
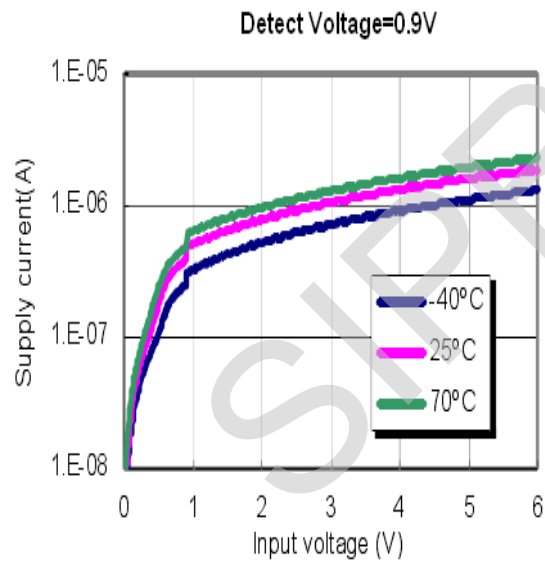

## Application Circuits

### Microcomputer Reset Circuit

Normally a reset circuit is required to protect the microcomputer system from malfunctions due to power line interruptions. The following examples show how different output configurations perform a reset function in various systems.

NMOS open drain output application for separate power supply

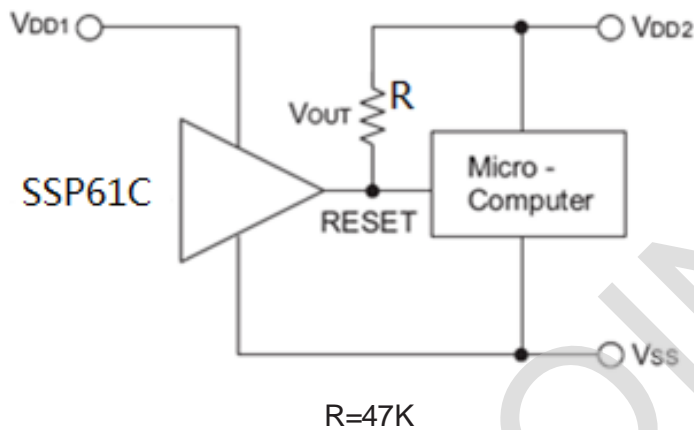

NMOS open drain output application with R-C delay

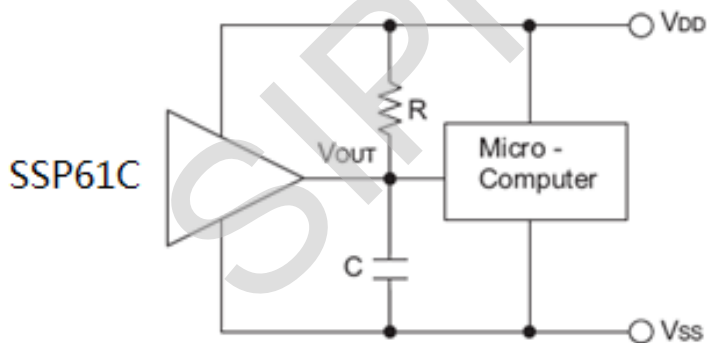

### Package Information

#### 3-pin SOT23-3 Outline Dimensions

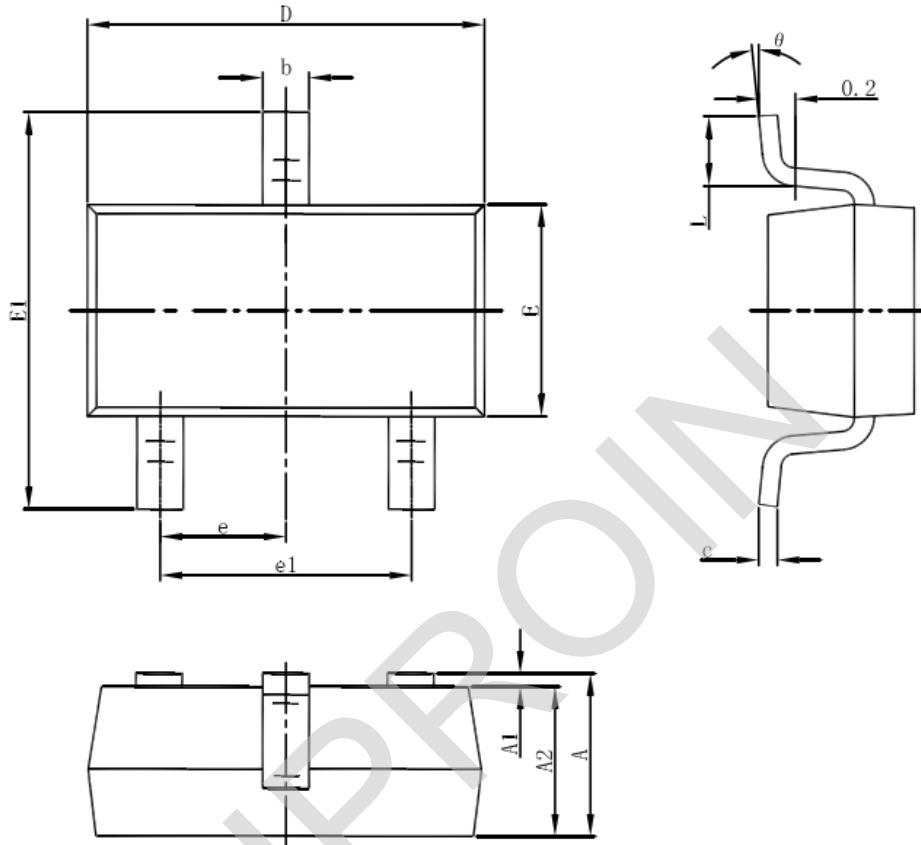

Symbol	Dimensions In Millimeters		Dimensions In Inches	
	Min	Max	Min	Max
A	1.050	1.250	0.041	0.049
A1	0.000	0.100	0.000	0.004
A2	1.050	1.150	0.041	0.045
b	0.300	0.500	0.012	0.020
c	0.100	0.200	0.004	0.008
D	2.820	3.020	0.111	0.119
E	1.500	1.700	0.059	0.067
E1	2.650	2.950	0.104	0.116
e	0.950(BSC)		0.037(BSC)	
e1	1.800	2.000	0.071	0.079
L	0.300	0.600	0.012	0.024
θ	0°	8°	0°	8°



## 3-pin SOT23 Outline Dimensions

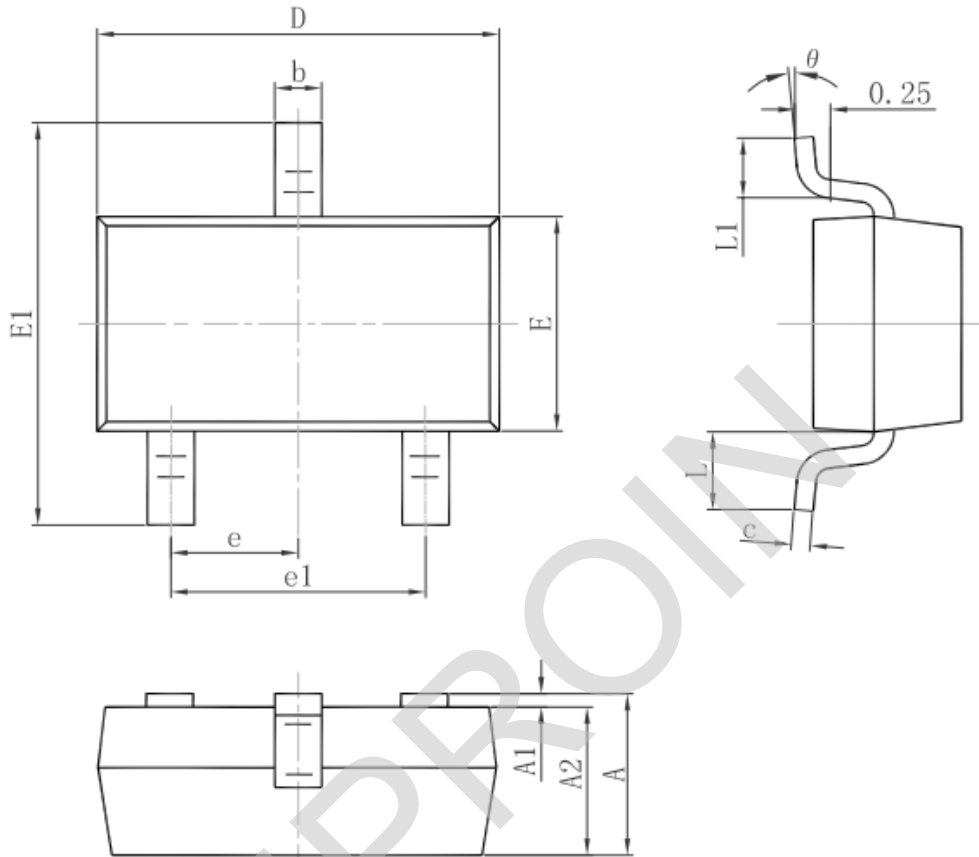

Symbol	Dimensions In Millimeters		Dimensions In Inches	
	Min.	Max.	Min.	Max.
A	0.900	1.150	0.035	0.045
A1	0.000	0.100	0.000	0.004
A2	0.900	1.050	0.035	0.041
b	0.300	0.500	0.012	0.020
c	0.080	0.150	0.003	0.006
D	2.800	3.000	0.110	0.118
E	1.200	1.400	0.047	0.055
E1	2.250	2.550	0.089	0.100
e	0.950 TYP.		0.037 TYP.	
e1	1.800	2.000	0.071	0.079
L	0.550 REF.		0.022 REF.	
L1	0.300	0.500	0.012	0.020
$\theta$	0°	8°	0°	8°

## X-ON Electronics

Largest Supplier of Electrical and Electronic Components

*Click to view similar products for [Supervisory Circuits](#) category:*

*Click to view products by [Siproin](#) manufacturer:*

Other Similar products are found below :

[NCP304LSQ38T1G](#) [NCP304LSQ40T1G](#) [NCP304LSQ42T1G](#) [NCP304LSQ43T1G](#) [NCP304LSQ46T1G](#) [NCP305LSQ11T1G](#)  
[NCP305LSQ16T1G](#) [NCP305LSQ17T1G](#) [NCP305LSQ18T1G](#) [NCP305LSQ24T1G](#) [NCP305LSQ25T1G](#) [NCP305LSQ29T1G](#)  
[NCP305LSQ31T1G](#) [NCP305LSQ32T1G](#) [NCP308MT250TBG](#) [NCP308SN300T1G](#) [NCP391FCALT2G](#) [NCV303LSN42T1G](#)  
[NCV308SN330T1G](#) [CAT1161LI-25-G](#) [CAT853STBI-T3](#) [MAX1232CPA](#) [MAX705CPA](#) [CAT1026LI-30-G](#) [CAT1320LI-25-G](#) [CAT872-30ULGT3](#) [LA-ispPAC-POWR1014-01TN48E](#) [NCP304HSQ18T1G](#) [NCP304HSQ29T1G](#) [NCP304LSQ27T1G](#) [NCP304LSQ29T1G](#)  
[NCP304LSQ45T1G](#) [NCP305LSQ26T1G](#) [NCP305LSQ35T1G](#) [NCP305LSQ37T1G](#) [NCP308MT300TBG](#) [NCV300LSN36T1G](#)  
[NCV302LSN30T1G](#) [NCV303LSN16T1G](#) [NCV303LSN22T1G](#) [NCV303LSN27T1G](#) [NCV33161DMR2G](#) [TC54VN2402EMB713](#)  
[MCP1316T-44NE/OT](#) [MCP1316MT-45GE/OT](#) [MCP1316MT-23LI/OT](#) [MCP1316T-26LE/OT](#) [MAX8997EWW+](#) [MAX821RUS+T](#)  
[MAX6725AKASYD3-LF-T](#)