

### Features

- Low voltage drop: 0.17V@100mA
- High input voltage: 12V
- Low temperature coefficient
- Large Output Current: >0.5A
- Low Quiescent Current: 2.0uA
- Output voltage accuracy: tolerance  $\pm 2\%$
- Built-in current limiter
- SOT-89-3L package

### Applications

- Battery-powered equipment
- Hand-Hold Equipment
- GRS Receivers
- Wireless LAN

### General Description

The SSP6201 series is a group of positive voltage output, three-pin regulators, that provide a high current even when the input/output voltage differential is small. Low power consumption and high accuracy is achieved through CMOS and laser trimming technologies.

The SSP6201 consists of a high-precision voltage reference, an error amplification circuit, and a current limited output driver. Transient response to load variations have improved in comparison to the existing series. SOT-89-3L packages is available.

### Selection Table

Part No.	Output Voltage	Package	Marking
SSP6201P302PR	3.0V	SOT-89-3L	130N
SSP6201P332PR	3.3V		133N
SSP6201P402PR	4.0V		140N
SSP6201P452PR	4.5V		145N
SSP6201P502PR	5.0V		150N

### Order Information

SSP6201P①②③④⑤

Designator	Symbol	Description
① ②	Integer	Output Voltage(2.1V~5.0V)
③	2	Output voltage accuracy: tolerance $\pm 2\%$
④	P	Package:SOT-89-3L
⑤	R	RoHS / Pb Free
	G	Halogen Free

Note: "①②" stands for output voltages. Other voltages can be specially customized

Block Diagram

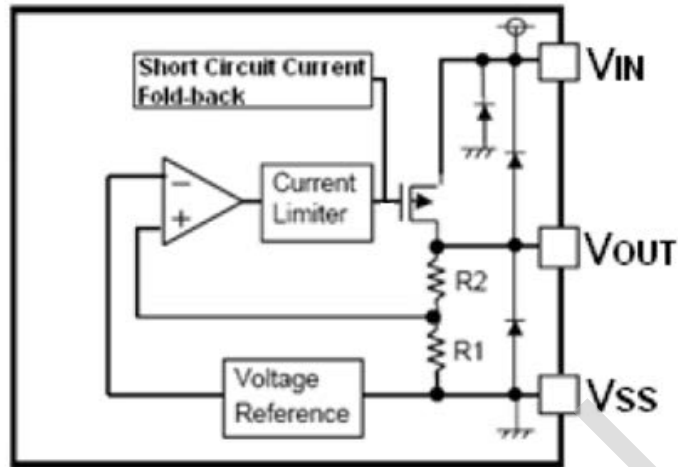

Pin Assignment

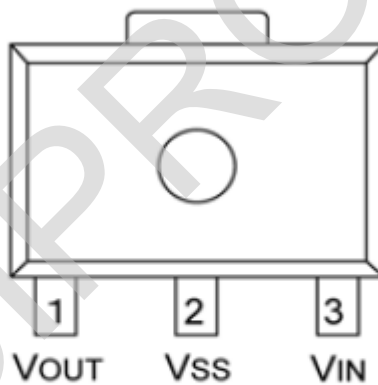

SOT-89  
(TOP VIEW)

**Absolute Maximum Ratings**

Supply Voltage .....-0.3V to 15V      Storage Temperature .....-40°C to 125°C  
 Operating Temperature .....-40°C to 85°C

Note: These are stress ratings only. Stresses exceeding the range specified under “Absolute Maximum Ratings” may cause substantial damage to the device. Functional operation of this device at other conditions beyond those listed in the specification is not implied and prolonged exposure to extreme conditions may affect device reliability.

### Electrical Characteristics

SSP6201 for any output voltage

(Ta=25°C)

Parameter	Symbol	Conditions	Min.	Typ.	Max.	Unit
Output Voltage	Vout	Vin=Vout+1V 1.0mA≤Iout≤30mA	Vout×0.98	--	Vout×1.02	V
Output Current*1	Iout	Vin-Vout=1V	--	250	--	mA
Low dropout*2	Vdrop	Refer to the next table				
Line Regulation	$\frac{\Delta V_{OUT}}{\Delta V_{IN} \times V_{OUT}}$	1.6V≤Vin≤8V Iout=100mA	--	0.05	0.2	%/V
Load Regulation	ΔVout	Vin= Vout+1V 1.0mA≤Iout≤100mA	--	12	30	mV
Output voltage Temperature Coefficiency	$\frac{\Delta V_{OUT}}{\Delta Ta}$	Iout=30mA 0°C≤Ta≤70°C	--	±100	--	Ppm/°C
PSRR	PSRR	F=1KHz Vin=Vout+1V	--	40	--	dB
Supply Current	Iss1	--	--	2	--	uA
Input Voltage	Vin	--	--	--	15	V

### Electrical Characteristics by Output Voltage:

Output Voltage Vout(V)	Dropout Voltage Vdif (V)		
	Conditions	Typ.	Max.
Vout ≤ 2.0V	Iout=60 mA	0.1	0.12
2.0 < Vout ≤ 3.0	Iout=80 mA	0.12	0.14
3.0 < Vout ≤ 4.0	Iout=100 mA	0.16	0.18
4.0 < Vout ≤ 5.0		0.17	0.18
3.0 < Vout ≤ 4.0	Iout=200 mA	0.21	0.24
4.0 < Vout ≤ 14.0		0.20	0.22
3.0 < Vout ≤ 4.0	Iout=500 mA	0.7	0.75
4.0 < Vout ≤ 14.0		0.72	0.76

### Typical Application

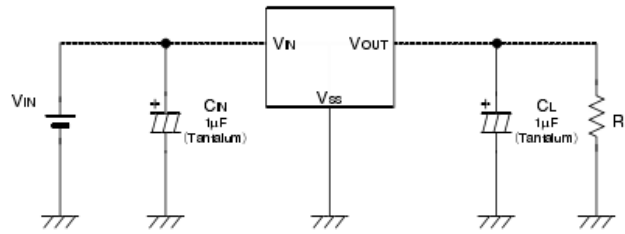

Note1: Input capacitor  $C_{IN}=1\mu F$ .

Note2: Output capacitor  $C_{OUT}=1\mu F/6.8\mu F$  (1µF Tantalum capacitor or 6.8µF ceramic capacitor is recommended).

### Typical Performance Characteristics

(1) Output Voltage vs Input voltage and Output Voltage vs. Output Current and Input Transient Response

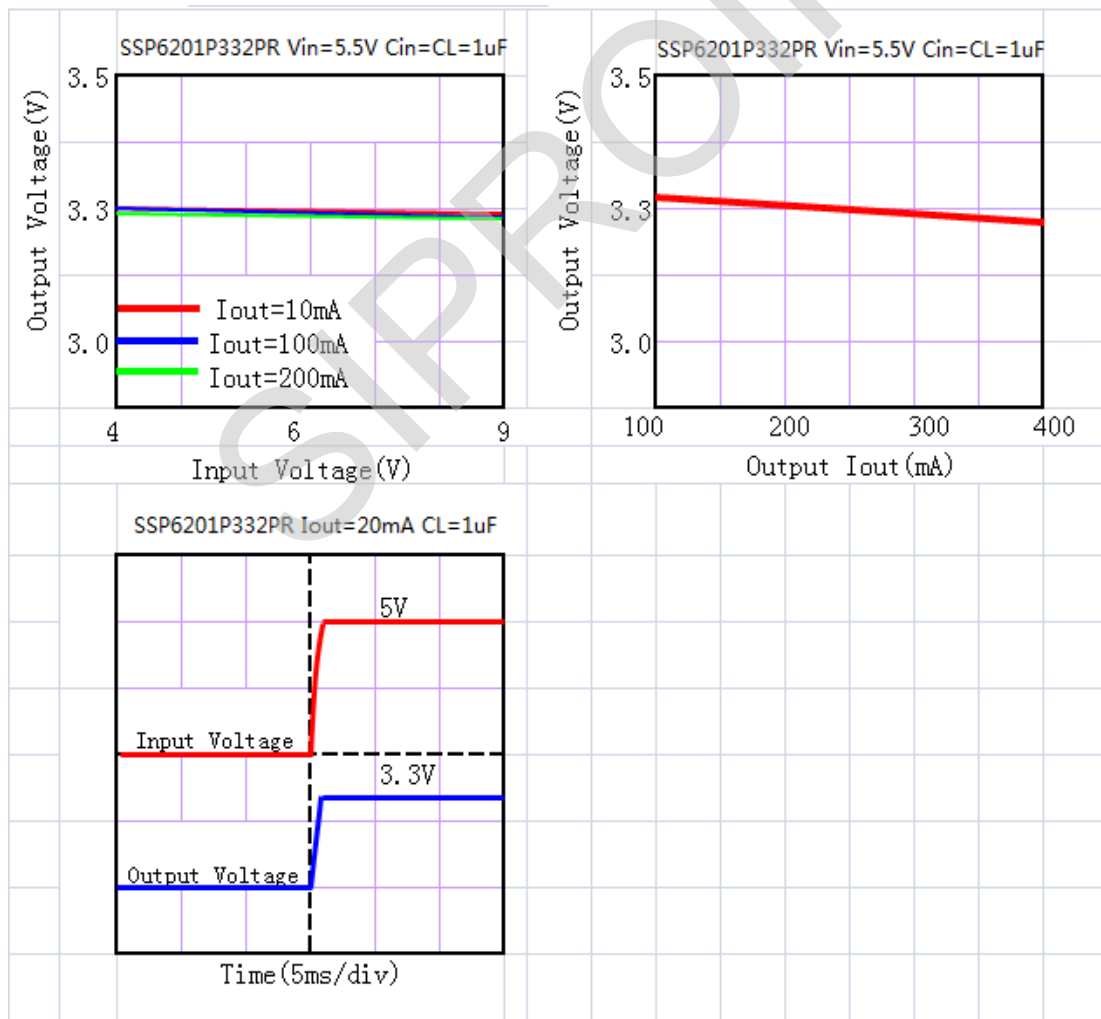

(2) Output Voltage vs. Ambient Temperature

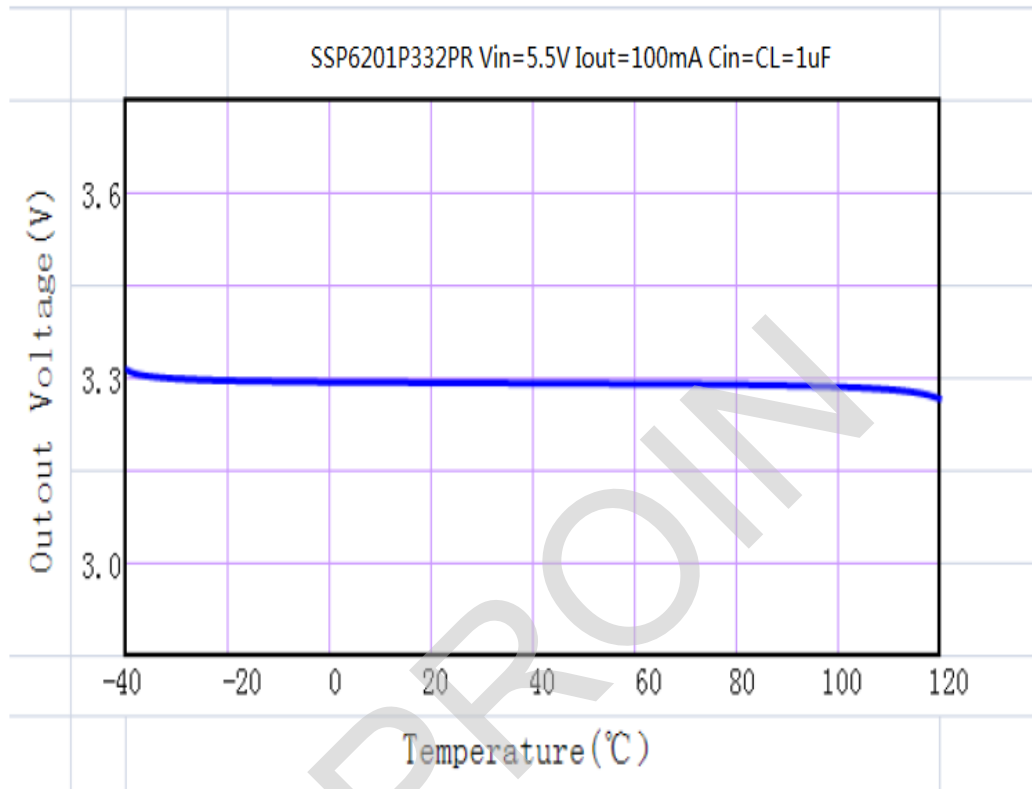

Package Information  
3-pin SOT-89-3L Outline Dimensions

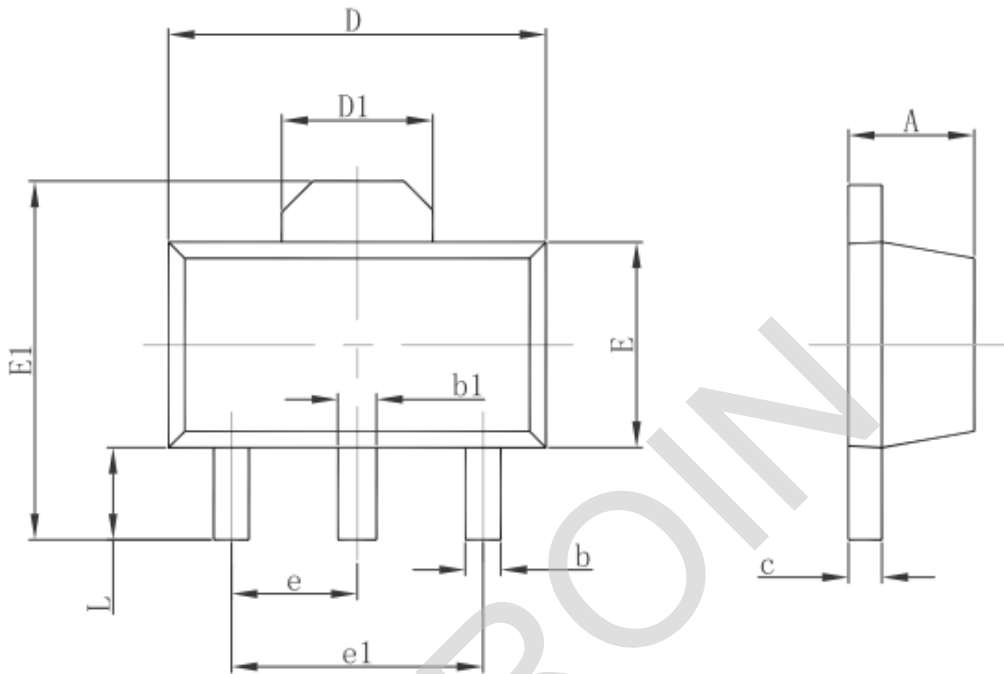

Symbol	Dimensions In Millimeters		Dimensions In Inches	
	Min.	Max.	Min.	Max.
A	1.400	1.600	0.055	0.063
b	0.320	0.520	0.013	0.020
b1	0.400	0.580	0.016	0.023
c	0.350	0.440	0.014	0.017
D	4.400	4.600	0.173	0.181
D1	1.550 REF.		0.061 REF.	
E	2.300	2.600	0.091	0.102
E1	3.940	4.250	0.155	0.167
e	1.500 TYP.		0.060 TYP.	
e1	3.000 TYP.		0.118 TYP.	
L	0.900	1.200	0.035	0.047

## X-ON Electronics

Largest Supplier of Electrical and Electronic Components

*Click to view similar products for [LDO Voltage Regulators](#) category:*

*Click to view products by [Siproin](#) manufacturer:*

Other Similar products are found below :

[AP7363-SP-13](#) [L79M05TL-E](#) [AP7362-HA-7](#) [PT7M8202B12TA5EX](#) [TCR3DF185,LM\(CT](#) [TCR3DF45,LM\(CT](#) [TLE4473G V52](#) [059985X](#)  
[NCP4687DH15T1G](#) [701326R](#) [NCV8170AXV250T2G](#) [SCD337BTG](#) [AP7315-25W5-7](#) [AP2111H-1.2TRG1](#) [ZLDO1117QK50TC](#) [AZ1117ID-](#)  
[ADJTRG1](#) [TCR3DG12,LF](#) [MIC5514-3.3YMT-T5](#) [SCD7912BTG](#) [NCP154MX180270TAG](#) [SCD33269T-5.0G](#) [NCV8170BXV330T2G](#)  
[NCV8170BMX330TCG](#) [NCV8170AMX120TCG](#) [NCP706ABMX300TAG](#) [NCP153MX330180TCG](#) [NCP114BMX075TCG](#) [MC33269T-3.5G](#)  
[CAT6243-ADJCMT5T](#) [TCR3DG33,LF](#) [TCR4DG35,LF](#) [TAR5S15U\(TE85L,F\)](#) [TAR5S18U\(TE85L,F\)](#) [TCR3UG19A,LF](#) [TCR4DG105,LF](#)  
[MPQ2013AGG-5-P](#) [NCV8170AMX360TCG](#) [TLE4268GSXUMA2](#) [NCP715SQ15T2G](#) [MIC5317-3.0YD5-T5](#) [NCV563SQ18T1G](#)  
[NCP715MX30TBG](#) [NCV8702MX25TCG](#) [NCV8170BXV120T2G](#) [MIC5317-1.2YD5-T5](#) [NCV8170AMX150TCG](#) [NCV8170BMX150TCG](#)  
[AP2213D-3.3TRG1](#) [NCV8170BMX120TCG](#) [NCV8170BMX310TCG](#)