

Synchronous Step-Up Converter with Ultra Low Quiescent Current

SSP8099

General Description

The SSP8099 is a synchronous step-up converter . It is designed for products powered by alkaline battery, NiMH rechargeable battery, Li-Mn battery or rechargeable Li-Ion battery, for which high efficiency under light load condition is critical to achieve long battery life operation.

The SSP8099 can support up to 300mA output current from 3.3V to 5V conversion, and achieve up to 90% efficiency at 200mA load.

The SSP8099 also offers both down mode and pass-through operation for different applications. In down mode, the output voltage can still be regulated at target value even when input voltage is higher than output voltage. In pass-through mode, the output voltage follows input voltage. The SSP8099 exits down mode and enters into pass-through mode when $V_{IN} > V_{OUT} + 0.3V$.

The SSP8099 supports true shutdown function when it is disabled, which disconnects the load from the input supply to reduce the current consumption.

The SSP8099 offers both adjustable output voltage version and fixed output voltage versions. It is available in Green WLCSP-1.22×0.83-6B and TDFN-2×2-6AL packages.

Features

- Operating Input Voltage Range: 0.9V to 5.2V
- Ultra Low Quiescent Current
 - Low shutdown mode current: $<1\mu A$
 - Ultra Low IQ into VIN Pin: $<2\mu A$
- 1.0MHz Fixed Frequency Operation
- Adjustable Output Voltage from 2.5V to 5.2V
- Fixed Output Voltage Versions Available
- Power-Save Mode for Improved Efficiency at Low Output Power
- Regulated Output Voltage in Down Mode
- True Disconnection During Shutdown
- Up to 90% Efficiency from 10mA to 300mA Load
- -40°C to +85°C Operating Ambient Temperature Range
- Available in Green WLCSP-1.22×0.83-6B and TDFN-2×2-6AL Packages

APPLICATIONS

- Single-Cell Li-Ion to 5V Converters
- Handheld Instruments
- Wearable Applications
- Low Power Wireless Applications
- Battery Powered Systems

Order information

| Product model | Package | Manner of packing | Minimum packing quantity |
|---------------|--------------------|-------------------|--------------------------|
| SSP8099-XXYG | WLCSP-1.22×0.83-6B | Reel | 3000 |
| SSP8099-XXYT | TDFN-2×2-6AL | | 3000 |
| SSP8099-ADJYG | WLCSP-1.22×0.83-6B | | 3000 |
| SSP8099-ADJYT | TDFN-2×2-6AL | | 3000 |

Note: "XX" stands for output voltages. Output Voltage: 2.5V、3.0V、3.3V、3.6V、4.5V、5V

"ADJ" means the output voltage is adjustable.

FUNCTIONAL BLOCK DIAGRAM

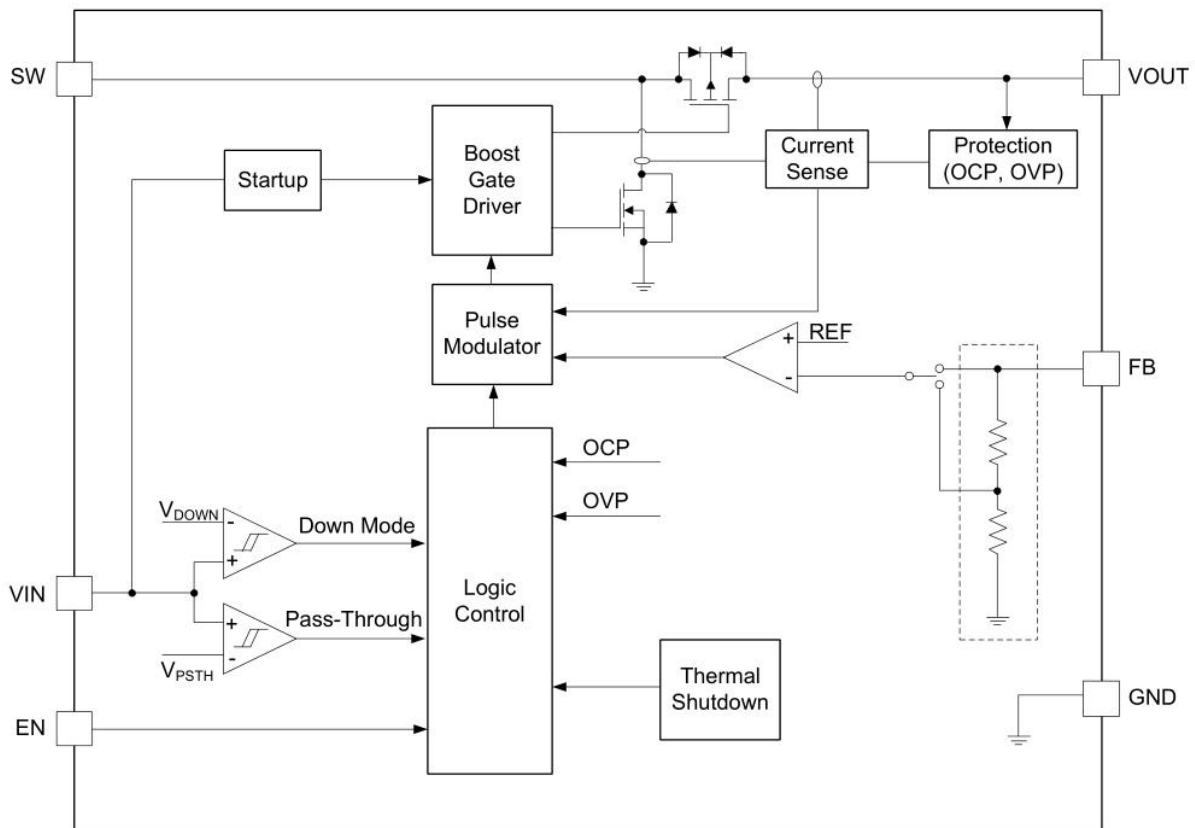

PIN CONFIGURATIONS

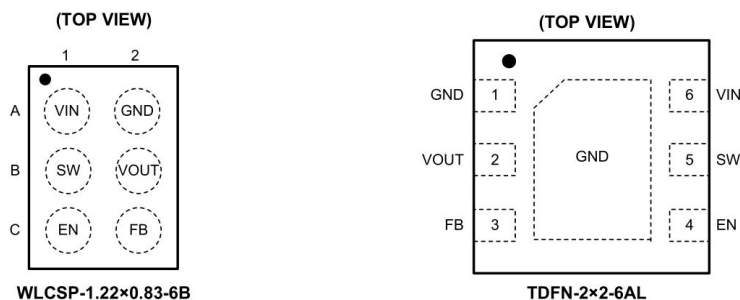

PIN DESCRIPTION

| PIN | | NAME | TYPE | FUNCTION |
|--------------------|--------------|------|------|--|
| WLCSP-1.22×0.83-6B | TDFN-2×2-6AL | | | |
| A1 | 6 | VIN | P | Power Supply Input. |
| A2 | 1 | GND | G | Ground. |
| B1 | 5 | SW | O | Switch Pin of the Converter. It is connected to the inductor. |
| B2 | 2 | VOUT | O | Boost Converter Output. |
| C1 | 4 | EN | I | Enable Logic Input. Logic high voltage enables the device; logic low voltage disables the device. Do not leave it floating. |
| C2 | 3 | FB | I | Voltage Feedback of Adjustable Output Voltage. Connect to the center tap of a resistor divider to program the output voltage. Connect to the GND pin or keep floating for fixed output voltage versions. |
| — | Exposed Pad | GND | — | Connect to GND. |

NOTE: I: input, O: output, G: ground, P: power for the circuit

Application Circuits

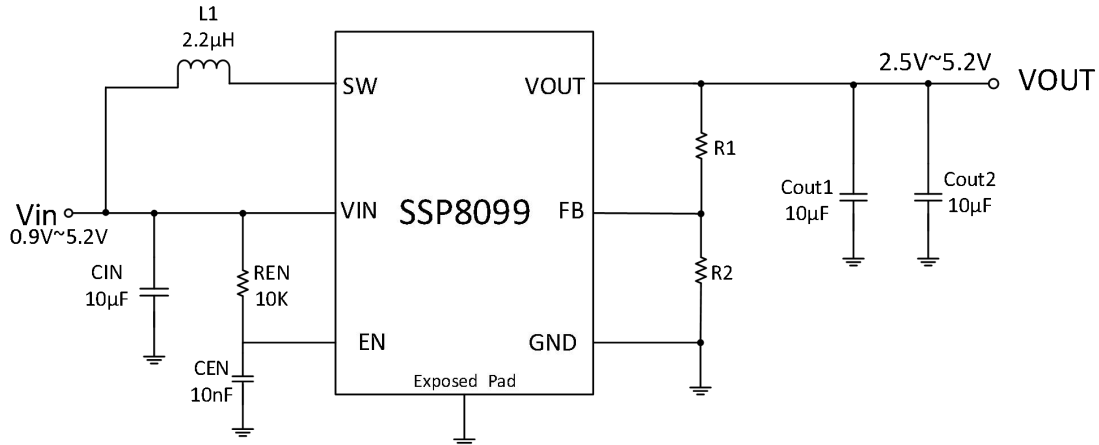

Adjustable Output Voltage Version

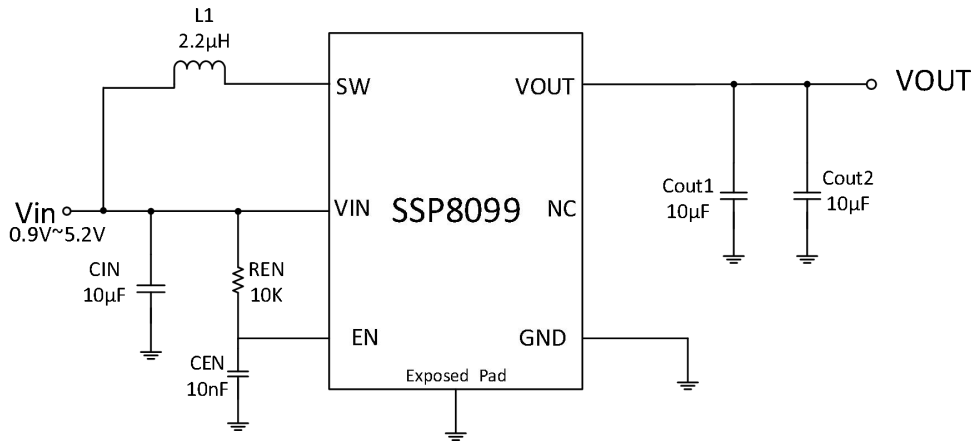

Fixed Output Voltage Version

ABSOLUTE MAXIMUM RATINGS

| | |
|---|-----------------|
| VIN, SW, VOUT, FB, EN to GND | -0.3V to 6.0V |
| Package Thermal Resistance | |
| WLCSP-1.22×0.83-6B, θ_{JA} | 143°C/W |
| TQFN-2×2-6AL, θ_{JA} | 105°C/W |
| Junction Temperature | +150°C |
| Storage Temperature | -65°C to +150°C |
| Lead Temperature (Soldering, 10s) | +260°C |
| ESD Susceptibility | |
| HBM | 2000V |

RECOMMENDED OPERATING CONDITIONS

| | |
|--|-----------------------------|
| Input Voltage Range | 0.9V ⁽¹⁾ to 5.2V |
| Output Voltage Range | 2.5V to 5.2V |
| Operating Ambient Temperature Range | -40°C to +85°C |
| Operating Junction Temperature Range | -40°C to +125°C |

NOTE (1): Refer to the “Startup and Low Supply Voltage Operation” for detailed description.

ELECTRICAL CHARACTERISTICS

(VIN = 0.9V to 5.2V, C IN = 10μF, C OUT = 20μF, Full = -40°C to +85°C, typical values are at VIN = 3.7V, T A = +25°C, unless otherwise noted.)

| PARAMETER | SYMBOL | CONDITIONS | TEMP | MIN | TYP | MAX | UNITS | | |
|--------------------------------|--------|---|-------|-----------------------|-------|-------|-------|-------|---|
| Power Supply | | | | | | | | | |
| Input Voltage Range | VIN | | +25°C | 0.9 | | 5.2 | V | | |
| Quiescent Current into VIN Pin | I Q | IC enabled, No load, no switching(Vin=Vout) | Full | | 0.05 | 0.2 | μA | | |
| | | IC enabled, No load, no switching, boost or down mode | Full | | 1 | 2 | μA | | |
| Shutdown Current into VIN Pin | I SD | EN = GND, VIN = 3.6V | Full | | 0.1 | 1 | μA | | |
| Output | | | | | | | | | |
| Output Voltage Range | VOUT | | Full | 2.5 | | 5.2 | V | | |
| Output Voltage | | SSP8099 -5.0, VIN < VOUT , PWM mode | Full | 4.85 | 5.00 | 5.09 | V | | |
| | | SSP8099 -5.0, VIN < VOUT , PFM mode | +25°C | | 5.08 | | V | | |
| | | SSP8099 -4.5, VIN < VOUT , PWM mode | Full | 4.37 | 4.50 | 4.58 | V | | |
| | | SSP8099 -4.5, VIN < VOUT , PFM mode | +25°C | | 4.57 | | V | | |
| | | SSP8099 -3.6, VIN < VOUT , PWM mode | Full | 3.50 | 3.60 | 3.67 | V | | |
| | | SSP8099 -3.6, VIN < VOUT , PFM mode | +25°C | | 3.65 | | V | | |
| | | SSP8099 -3.3, VIN < VOUT , PWM mode | Full | 3.21 | 3.30 | 3.35 | V | | |
| | | SSP8099 -3.3, VIN < VOUT , PFM mode | +25°C | | 3.35 | | V | | |
| | | SSP8099 -3.0, VIN < VOUT , PWM mode | Full | 2.92 | 3.00 | 3.05 | V | | |
| | | SSP8099 -3.0, VIN < VOUT , PFM mode | +25°C | | 3.04 | | V | | |
| | | SSP8099 -2.5, VIN < VOUT , PWM mode | Full | 2.44 | 2.50 | 2.54 | V | | |
| | | SSP8099 -2.5, VIN < VOUT , PFM mode | +25°C | | 2.54 | | V | | |
| | | Feedback Reference Voltage | V REF | VIN < VOUT , PWM mode | Full | 0.975 | 1.000 | 1.025 | V |
| | | | | VIN < VOUT , PFM mode | +25°C | | 1.020 | | V |

| PARAMETER | SYMBOL | CONDITIONS | TEMP | MIN | TYP | MAX | UNITS |
|--|-------------|------------------------------|-------|-----------|-----|-----------|-------|
| Output Over-Voltage Protection Threshold | V OVP | VOUT rising | +25°C | 5.50 | 5.8 | 5.95 | V |
| OVP Hysteresis | | | +25°C | | 100 | | mV |
| Leakage Current into FB Pin | I FB_LKG | V FB = 1.1V | Full | | 10 | 50 | nA |
| Switching | | | | | | | |
| Switching Frequency | f SW | VIN = 3.7V | Full | | 1.0 | | MHz |
| Power Switch | | | | | | | |
| Low-side Switch On-Resistance | R DS(ON)_LS | VOUT = 5.0V (TDFN) | +25°C | | 280 | 400 | mΩ |
| | | VOUT = 5.0V (WLCSP) | +25°C | | 220 | 310 | mΩ |
| | | VOUT = 3.3V (TDFN) | +25°C | | 340 | 480 | mΩ |
| | | VOUT = 3.3V (WLCSP) | +25°C | | 290 | 390 | mΩ |
| Rectifier On-Resistance | R DS(ON)_HS | VOUT = 5.0V (TDFN) | +25°C | | 270 | 350 | mΩ |
| | | VOUT = 5.0V (WLCSP) | +25°C | | 250 | 350 | mΩ |
| | | VOUT = 3.3V (TDFN) | +25°C | | 350 | | mΩ |
| | | VOUT = 3.3V (WLCSP) | +25°C | | 330 | | mΩ |
| Current Limit Threshold | I LIM | VOUT > 2.5V, boost operation | +25°C | 0.89 | 1.3 | 1.62 | A |
| | | VOUT = 2.5V, boost operation | +25°C | 0.57 | 0.8 | 1.06 | A |
| Control Logic | | | | | | | |
| EN Input Low Voltage Threshold | V IL | VIN ≤ 1.5V | Full | | | 0.8 × VIN | V |
| | | VIN > 1.5V | Full | | | 0.4 | V |
| EN Input High Voltage Threshold | V IH | VIN ≤ 1.5V | Full | 0.8 × VIN | | | V |
| | | VIN > 1.5V | Full | 1.2 | | | V |
| Leakage Current into EN Pin | I EN_LKG | V EN = 5.0V | +25°C | | | 300 | nA |

DETAILED DESCRIPTION

The SSP8099 synchronous step-up converter is designed for alkaline battery, coin-cell battery, Li-Ion or Li-Polymer battery powered systems, which requires long battery running time and tiny solution size. The SSP8099 can operate with a wide input voltage from 0.9V to 5.2V.

The SSP8099 operates in peak current mode with typical 1.3A peak switch current limit. The SSP8099 provides the true shutdown function and the load is completely disconnected from the input so as to minimize the leakage current. It also adopts down mode and pass-through operation when input voltage is close to or higher than the regulated output voltage.

The SSP8099 is available in both adjustable and fixed output voltage versions.

Enable and Disable

When the EN pin is pulled to high, the SSP8099 is enabled. When the EN pin is pulled to low, the SSP8099 goes into shutdown mode. In shutdown mode, the device stops switching and the rectifying PMOS fully turns off, providing the completed disconnection between input and output. Less than 1 μ A input current is consumed in shutdown mode. In particular, it is recommended to avoid pulling EN high to start the boost when the power supply voltage is higher than 5.2V. See Figure 1, a RC network of 10k Ω and 10nF at EN pin is suggested to ensure the EN active signal a bit later than the spike of the power supply.

Startup and Low Supply Voltage Operation

The SSP8099 is able to start up with 0.9VIN_{input} voltage with larger than 3k Ω load. However, if the load during startup is too heavy that the SSP8099 fails to charge the output voltage to above 2.2V, then it won't be able to start up successfully.

The SSP8099 may not be shut down by pulling the EN to logic low when the supply voltage is below 0.85V, while the supply voltage can drop to as low as 0.4V for maintain the output voltage with light loadings.

Current Limit Operation

The SSP8099 employs cycle-by-cycle over-current protection (OCP) function. If the inductor peak current reaches the current limit threshold I_{LIM} , the main switch turns off so as to stop further increase of the input current. In this case the output voltage will decrease until the power balance between input and output is achieved. If the output drops below the input voltage,

The SSP8099 enters into down mode. The peak current is still limited by I_{LIM} cycle-by-cycle in down mode. If the output drops below 2.2V, the SSP8099 enters into startup process again. In pass-through operation, current limit function is not enabled.

Output Short-to-Ground Protection

The SSP8099 starts to limit the switch current to about 200mA when the output voltage is below 2.2V. If short-to-ground condition occurs, switch current is limited at about 200mA. Once the short circuit is released, the SSP8099 goes back to soft start again and regulates the output voltage.

Over-Voltage Protection

SSP8099 has an output over-voltage protection (OVP) to protect the device in case that the external feedback resistor divider is wrongly connected. When the output voltage of the SSP8099 exceeds the OVP threshold of 5.8V, the device stops switching. Once the output voltage falls 0.1V below the OVP threshold,

the device starts operating again.

Power-Save Mode Operation under Light Load Condition

The step-up converter of SSP8099 enters into power-save mode operation under light load condition.

Down Mode Regulation and Pass-Through Operation

The SSP8099 features down mode and pass-through operation when input voltage is close to or higher than output voltage.

DETAILED DESCRIPTION

In the down mode, output voltage is regulated at target value even when $V_{IN} > V_{OUT}$. The control circuit changes the behavior of the rectifying PMOS by pulling its gate to input voltage instead of to ground. In this way, the voltage drop across the PMOS is increasing as high as to regulate the output voltage. The power loss also increases in this mode, which needs to be taken into account for thermal consideration.

In the pass-through operation, the step-up converter stops switching. The rectifying PMOS constantly turns on and low-side switch constantly turns off. The output voltage is the input voltage minus the voltage drop across the DC resistance (DCR) of the inductor and the on-resistance of the rectifying PMOS.

With V_{IN} ramping up, the SSP8099 goes into down mode first when $V_{IN} > V_{OUT} - 100\text{mV}$. It stays in down mode until $V_{IN} > V_{OUT} + 0.3\text{V}$ and then goes automatically into pass-through operation. In the pass-through operation, output voltage follows input voltage. The SSP8099 exits pass-through mode and goes back to down mode when V_{IN} ramps down to 101% of the target output voltage. It stays in down mode until input voltage falls 150mV below the output voltage, returning to boost operation.

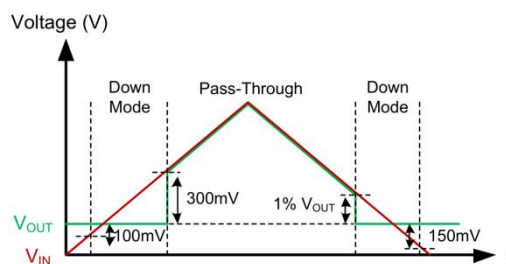

Down Mode and Pass-Through Operation

Design Requirements

A typical application example is the memory LCD, which normally requires 5VOUTput as its bias voltage and only consumes less than 1mA current. The following design procedure can be used to select external component values for the SSP8099 .

Table 1. Design Requirements

| PARAMETERS | VALUES |
|-----------------------|-------------|
| Input Voltage | 2.7V ~ 4.2V |
| Output Voltage | 5V |
| Output Current | 1mA |
| Output Voltage Ripple | ±50mV |

Programming the Output Voltage

There are two ways to set the output voltage of the SSP8099. For adjustable output voltage version, select the external resistor divider R 1 and R 2 , as shown in Equation 1, and the output voltage is programmed to the desired value. When the output voltage is regulated, the typical voltage at the FB pin is V REF of 1.0V.

$$V_{OUT} = V_{REF} \times (R_1 + R_2) / R_2 \quad (1)$$

For fixed output voltage versions, the FB pin should be connected to GND or kept floating. The SSP8099 offers diverse fixed voltage versions.

In this example, 5VOUTput is required to bias the memory LCD. For the best accuracy, the current following through R2 should be 100 times larger than FB pin leakage current. Changing R2 towards a lower value increases the robustness against noise injection. Changing R2 towards higher values reduces the FB divider current for achieving the highest efficiency at low load currents. 1MΩ and 249kΩ resistors are selected for R 1 and R 2 in this example. High accuracy resistors are recommended for better output voltage accuracy.

Maximum Output Current

The maximum output capability of the SSP8099 is determined by the input to output ratio and the current limit of the step-up converter. It can be estimated by Equation 2.

$$I_{OUT(MAX)} = V_{IN} * (I_{LIM} - I_{LH} / 2) * \eta / V_{OUT} \quad (2)$$

where η is the conversion efficiency, using 85% for estimation; I LH is the current ripple value and I LIM is the switch current limit.

Minimum input voltage, maximum boost output voltage and minimum current limit I LIM should be used as the worst case condition for the estimation.

APPLICATION INFORMATION

Inductor Selection

Because the selection of the inductor affects steady state operation, transient behavior, and loop stability, the inductor is the most important component in power regulator design. There are three important inductor specifications, inductor value, saturation current, and DC resistance (DCR).

The device has been optimized to operate with inductance values between 1 μ H and 2.2 μ H. For best stability consideration, a 2.2 μ H inductor is recommended for $V_{OUT} > 3.0V$ condition while choosing a 1 μ H inductor for applications under $V_{OUT} \leq 3.0V$ condition.

| VOUT (V) | Inductance (μ H) | Saturation Current (A) | DC Resistance (m Ω) | Size (L \times W \times H) | Part Number | Manufacturer |
|------------|-----------------------|------------------------|-----------------------------|--------------------------------|------------------|------------------|
| > 3.0 | 2.2 | 1.95 | 80 | 2.5 \times 2.0 \times 1.2 | 74404024022 | Würth Elektronik |
| | 2.2 | 1.7 | 92 | 2.5 \times 2.0 \times 1.1 | LQH2HPN2R2MJR | muRata |
| | 2.2 | 1.45 | 163 | 2.0 \times 1.6 \times 1.0 | VLS201610CX-2R2M | TDK |
| \leq 3.0 | 1.0 | 2.6 | 37 | 2.5 \times 2.0 \times 1.2 | 74404024010 | Würth Elektronik |
| | 1.0 | 2.3 | 48 | 2.5 \times 2.0 \times 1.0 | MLP2520W1R0MT0S1 | TDK |
| | 1.0 | 1.5 | 80 | 2.0 \times 1.2 \times 1.0 | LQM21PN1R0MGH | muRata |

Capacitor Selection

For best output and input voltage filtering, low ESR X5R or X7R ceramic capacitors are recommended.

The input capacitor minimizes input voltage ripple, suppresses input voltage spikes and provides a stable system rail for the device. An input capacitor value of 10 μ F is normally recommended to improve transient behavior of the regulator and EMI behavior of the total power supply circuit. A ceramic capacitor placed as close as possible to the VIN and GND pins of the device is recommended.

For the output capacitor of VOUT pin, small ceramic capacitors are recommended, placed as close as possible to the VOUT and GND pins of the device. If, for any reason, the application requires the use of large capacitors which cannot be placed close to the device, the use of a small ceramic capacitor with a capacitance value of 1 μ F in parallel to the large one is recommended. This small capacitor should be placed as close as possible to the VOUT and GND pins of the device.

From the power stage point of view, the output capacitor sets the corner frequency of the converter while the inductor creates a right-half-plane-zero. Consequently, with a larger inductor, a larger output capacitor must be used. The device has been optimized to operate with inductance values between 1 μ H and 2.2 μ H, so the minimal output capacitor value is 20 μ F (nominal value). Increasing the output capacitor makes the output ripple smaller in PWM mode.

When selecting capacitors, ceramic capacitor's derating effect under bias should be considered. Choose the right nominal capacitance by checking capacitor's DC bias characteristics. In this example, GRM188R60J106ME84D, which is a 10 μ F ceramic capacitor with high effective capacitance value at DC biased condition, is selected for VOUT rail.

In the case of load hot-plugging, the input capacitance of load device needs to be less than 1/10 of the output capacitance of SSP8099.

Typical Performance Characteristics

Test Conditions: SSP8099-5.0YT, $V_{out}=5V$, $L=2.2\mu H$, $C_{IN}=2*10\mu F$, $C_{OUT}=2*10\mu F$, $T_a=25^\circ C$, unless otherwise indicated.

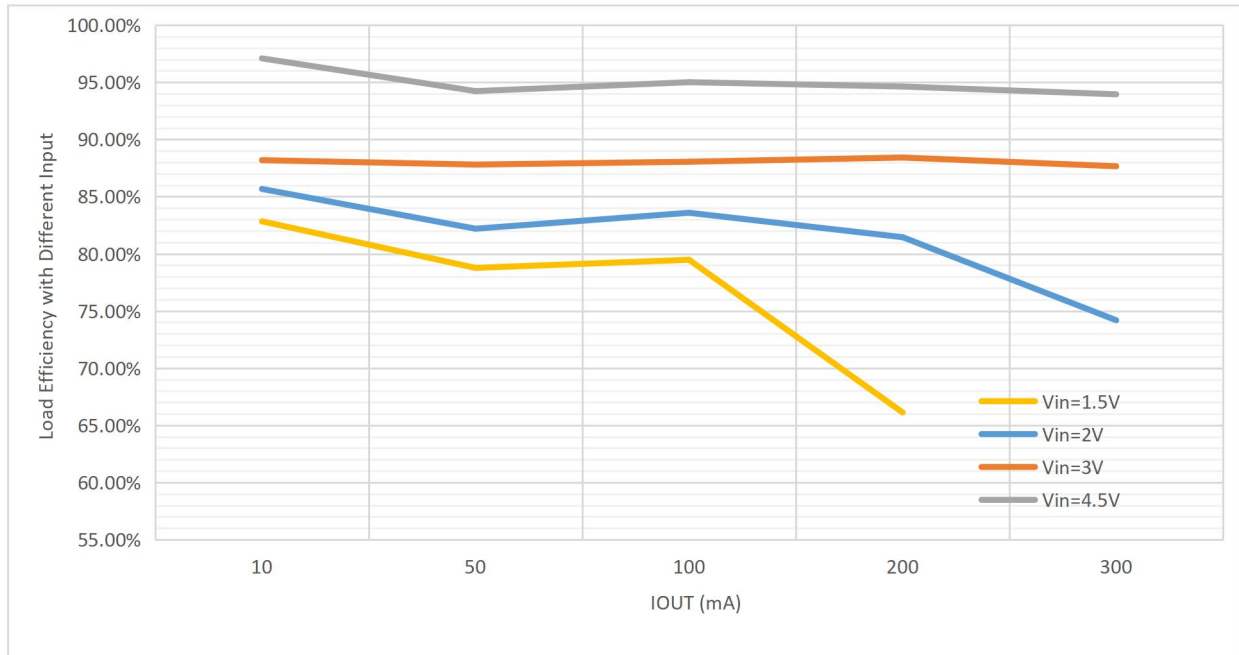

Layout

As for all switching power supplies, the layout is an important step in the design, especially at high peak currents and high switching frequencies. If the layout is not carefully done, the regulator could show stability problems as well as EMI problems. Therefore, use wide and short traces for the main current path and for the power ground paths. The input and output capacitor, as well as the inductor should be placed as close as possible to the device.

PACKAGE OUTLINE DIMENSIONS

WLCSP-1.22×0.83-6B

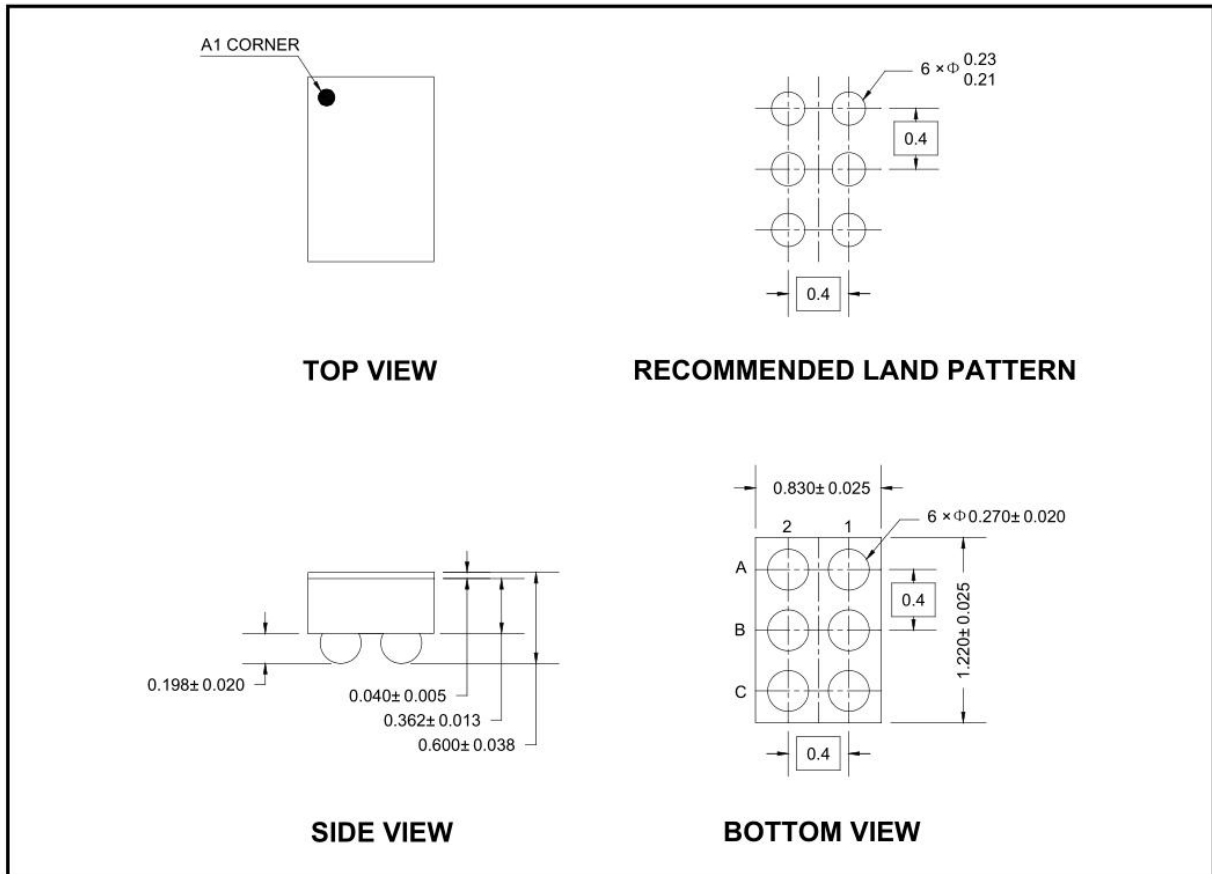

NOTE: All linear dimensions are in millimeters.

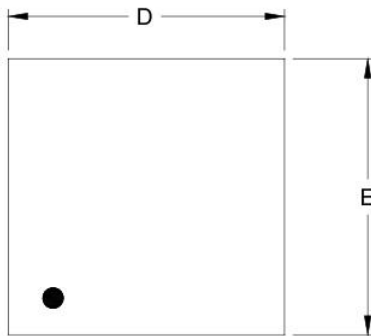
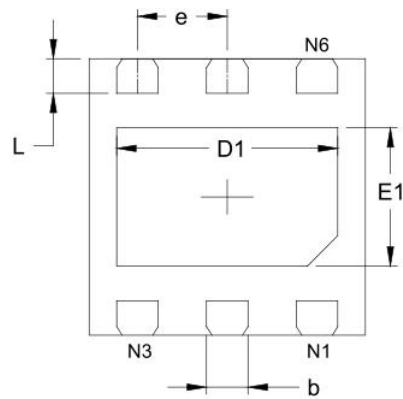
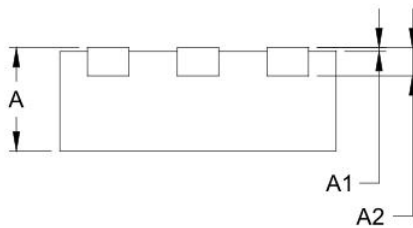
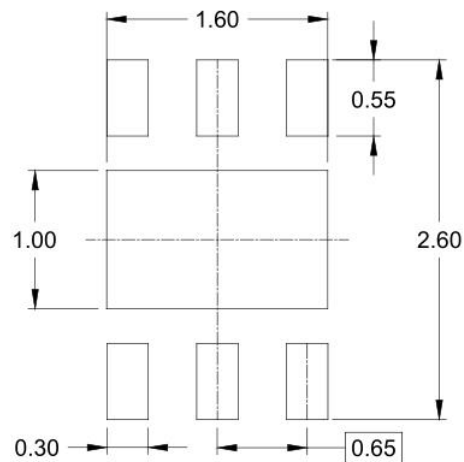
TDFN-2x2-6AL

TOP VIEW

BOTTOM VIEW

SIDE VIEW

RECOMMENDED LAND PATTERN (Unit: mm)

| Symbol | Dimensions In Millimeters | | Dimensions In Inches | |
|--------|------------------------------|-------|-------------------------|-------|
| | MIN | MAX | MIN | MAX |
| A | 0.700 | 0.800 | 0.028 | 0.031 |
| A1 | 0.000 | 0.050 | 0.000 | 0.002 |
| A2 | 0.203 REF | | 0.008 REF | |
| D | 1.900 | 2.100 | 0.075 | 0.083 |
| D1 | 1.500 | 1.700 | 0.059 | 0.067 |
| E | 1.900 | 2.100 | 0.075 | 0.083 |
| E1 | 0.900 | 1.100 | 0.035 | 0.043 |
| b | 0.250 | 0.350 | 0.010 | 0.014 |
| e | 0.650 BSC | | 0.026 BSC | |
| L | 0.174 | 0.326 | 0.007 | 0.013 |

Special Version

The company reserves the right of final interpretation of this specification.

Version Change Description

Versions: V1.0

Writer: XinCHun Li

Time: 2022.11.28

Modify the record:

1. Original Version

Statement

The information in the usage specification is correct at the time of publication, Shanghai Siproin Microelectronics Co. has the right to change and interpret the specification, and reserves the right to modify the product without prior notice. Users can obtain the latest version information from our official website or other effective channels before confirmation, and verify whether the relevant information is complete and up to date.

With any semiconductor product, there is a certain possibility of failure or failure under certain conditions. The buyer is responsible for complying with safety standards and taking safety measures when using the product for system design and complete machine manufacturing. The product is not authorized to be used as a critical component in life-saving or life-sustaining products or systems, in order to avoid potential failure risks that may cause personal injury or property loss.

X-ON Electronics

Largest Supplier of Electrical and Electronic Components

Click to view similar products for [Switching Controllers](#) category:

Click to view products by [Siproin](#) manufacturer:

Other Similar products are found below :

[NCP1218AD65R2G](#) [NCP1244BD065R2G](#) [NCP1336ADR2G](#) [NCP6153MNTWG](#) [NCP81101BMNTXG](#) [NCP81205MNTXG](#) [SJE6600](#)
[AZ7500BMTR-E1](#) [SG3845DM](#) [NCP1250BP65G](#) [NCP4204MNTXG](#) [NCP6132AMNR2G](#) [NCP81102MNTXG](#) [NCP81206MNTXG](#)
[NCP1240AD065R2G](#) [NCP1240FD065R2G](#) [NCP1361BABAYSNT1G](#) [NCP1230P100G](#) [NX2124CSTR](#) [SG2845M](#) [NCP1366BABAYDR2G](#)
[NCP81101MNTXG](#) [NCP81174NMNTXG](#) [NCP4308DMTTWG](#) [NCP4308AMTTWG](#) [NCP1366AABAYDR2G](#) [NCP1251FSN65T1G](#)
[NCP1246BLD065R2G](#) [MB39A136PFT-G-BND-ERE1](#) [NCP1256BSN100T1G](#) [LV5768V-A-TLM-E](#) [NCP1365BABCYDR2G](#)
[NCP1365AABCYDR2G](#) [NCP1246ALD065R2G](#) [AZ494AP-E1](#) [CR1510-10](#) [NCP4205MNTXG](#) [ISL69158IRAZ-T7A](#) [XRP6141ELTR-F](#)
[RY8017](#) [LP6260SQVF](#) [LP6298QVF](#) [ISL6121LIB](#) [ISL6225CA](#) [ISL6244HRZ](#) [ISL6268CAZ](#) [ISL6315IRZ](#) [ISL6420AIAZ-TK](#) [ISL6420AIRZ](#)
[ISL6420IAZ](#)