

Features

- Low power consumption:30uA (Typ.)
- Low voltage drop:0.06V@100mA(Typ.)
- Build-in Enable/Output Current Limit circuit
- High Ripple Rejection: 70dB@10kHz(Typ.)
- Output Voltage Range: 1.2V~5V
- Output voltage accuracy: tolerance $\pm 2\%$
- High input voltage (up to 5.5V)
- Standby Mode: Typ.<0.01 μ A
- Low temperature coefficient
- Low output noise(100uVRMS)
- SOT23-5 package

Applications

- Battery-powered equipment
- Communication equipment
- Mobile phones
- Portable games
- Cameras, Video cameras
- Reference voltage sources

General Description

The SSP9193 series are highly accurate, low noise, CMOS LDO Voltage Regulators. Offering low output noise, high ripple rejection ratio, low dropout and very fast turn-on times, the SSP9193 series is ideal for today's cutting edge mobile phone. Internally the SSP9193 includes a reference voltage source, error amplifiers, driver transistors, current limiters and phase compensators. The SSP9193's current limiters' feedback circuit also operates as a short protect for the output current limiter and the output pin. The output voltage is set by current trimming. Voltages are selectable in 100mV steps within a range of 1.2V to 5.0V. The SSP9193 series is also fully compatible with low ESR ceramic capacitors, reducing cost and improving output stability. This high level of output stability is maintained even during frequent load fluctuations, due to the excellent transient response performance and high PSRR achieved across a broad range of frequencies. The CE function allows the output of regulator to be turned off, resulting in greatly reduced power consumption.

Order Information

SSP9193-①②③④

Designator	Symbol	Description
①② (Stand for output voltage:1.2V~5V)	12	1.2V
	15	1.5V
	18	1.8V
	25	2.5V
	28	2.8V
	30	3.0V
	33	3.3V
③ (Stand for package)	M5	SOT23-5
④	R	RoHS / Pb Free

Typical Application Circuit

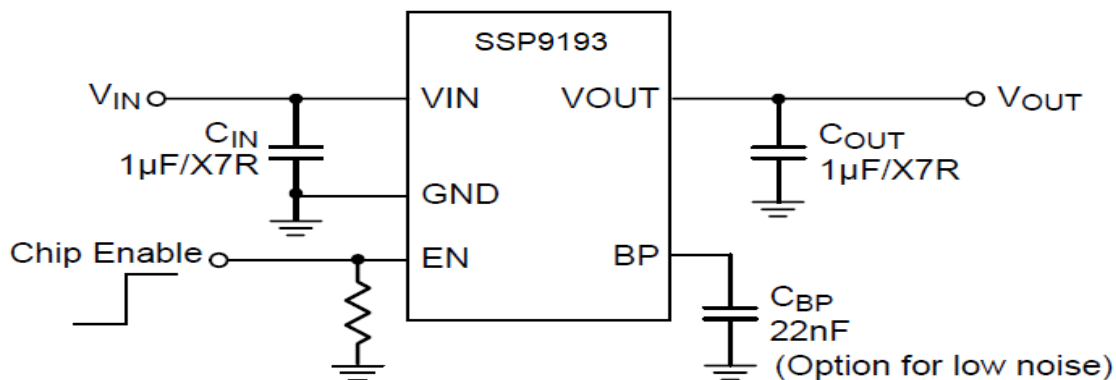

Package and Pin assignment

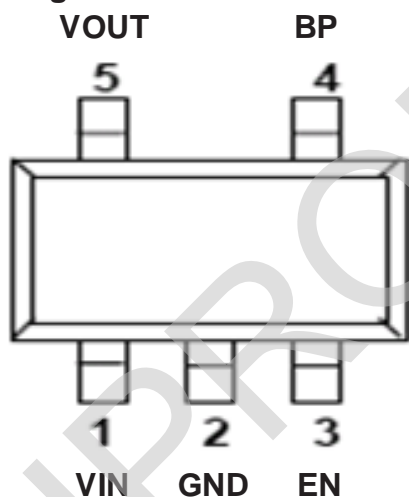

Functional Pin Description

Pin Name	Pin Function
EN	Chip Enable (Active High). Note that this pin is high impedance. There should be a pull low 100kΩ resistor connected to GND when the control signal is floating.
BP	Reference Noise Bypass. This pin can be floating. For lowest noise performance, connect a 22nF capacitor between the BP and GND pins.
GND	Ground.
VOUT	Output Voltage.
VIN	Power Input Voltage.

Recommended operating conditions (unless otherwise indicated, TA = 25 °C.)

Supply input voltage.....	2.5V to 5.5V	Junction temperature range.....	-40°C to 125°C
En input voltage.....	0V to 5.5V	Ambient temperature range.....	-40°C to 85°C

Block Diagram

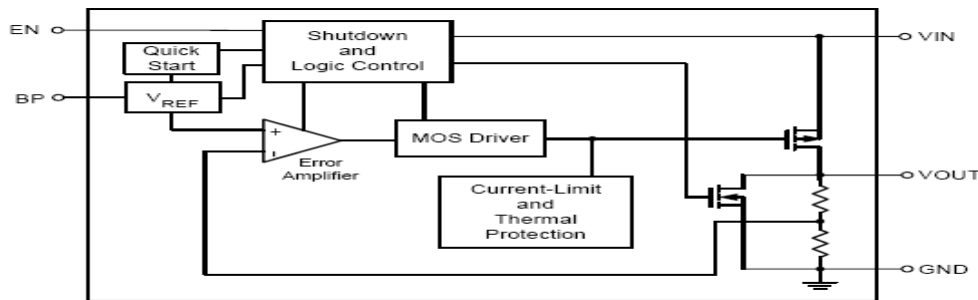

Electrical Characteristics

SSP9193 for any output voltage

Parameter	Symbol	Conditions	Min.	Typ.	Max.	Unit
Output Voltage	Vout	Vin=Vout+1V 1.0mA≤Iout≤30mA	Vout×0.98	--	Vout×1.02	V
Output Current*1	Iout	Vin-Vout=1V	--	400	500	mA
Low dropout*2	Vdrop	Iout=200mA Vout>2.8V	--	170	200	mV
		Iout=300mA Vout>2.8V	--	220	300	mV
Line Regulation	ΔVout1	Vin=(Vout+1) to 5.5V Iout=1mA	--	--	0.3	%
Load Regulation	ΔVout	Vin= Vout+1V 1.0mA≤Iout≤300mA	--	--	0.6	%
Quiescent Current	Iss1	VEN≥1.2V, IOUT=0mA	--	30	50	uA
Standby current	ISTBY	VEN=GND,shutdown	--	0.01	1	uA
EN Input Bias current	VEN=GND or VIN	VEN=GND or VIN	--	0	100	nA
VIL	EN Threshold	Vin=3V to 5.5V, shutdown	--	--	0.4	V
VIH		Vin=3V to 5.5V, strat-up	1.2	--	--	V
PSRR	Power supply rejection rate; F=100Hz	Cout=1uF;Iout=10mA	--	70	--	dB
	Power supply rejection rate; F=10KHz		--	50	--	
Output Noise	EN	BW=10Hz~100KHz	--	27	--	uVrms
Thermal shutdown temperature	TSD		--	165	--	℃
Thermal shutdown temperature	ΔTSD		--	30	--	℃

Operational Explanation

<Output Voltage Control>

The voltage divided by resistors R1 & R2 is compared with the internal reference voltage by the error amplifier. The P-channel MOSFET, which is connected to the V_{OUT} pin, is then driven by the subsequent output signal. The output voltage at the V_{OUT} pin is controlled and stabilized by a system of negative feedback. The current limit circuit and short protect circuit operate in relation to the level of output current. Further, the IC's internal circuitry can be shutdown via the CE pin's signal

<Low ESR Capacitors>

With the SSP9193 series, a stable output voltage is achievable even if used with low ESR capacitors as a phase compensation circuit is built-in. In order to ensure the effectiveness of the phase compensation, we suggest that an output capacitor (C_L) is connected as close as possible to the output pin (V_{OUT}) and the V_{SS} pin. Please use an output capacitor with a capacitance value of at least 1 μ F. Also, please connect an input capacitor (C_{IN}) of 0.1 μ F between the V_{IN} pin and the V_{SS} pin in order to ensure a stable power input. Stable phase compensation may not be ensured if the capacitor runs out capacitance when depending on bias and temperature. In case the capacitor depends on the bias and temperature, please make sure the capacitor can ensure the actual capacitance.

<Current Limiter, Short-Circuit Protection>

The SSP9193 series includes a combination of a fixed current limiter circuit & a feedback circuit, which aid the operations of the current limiter and circuit protection. When the load current reaches the current limit level, the fixed current limiter circuit operates and output voltage drops. As a result of this drop in output voltage, the feedback circuit operates, output voltage drops further and output current decreases. When the output pin is shorted, a current of about 50mA flows.

<EN Pin>

The IC's internal circuitry can be shutdown via the signal from the CE pin with the SSP9193 series. In shutdown mode, output at the V_{OUT} pin will be pulled down to the V_{SS} level via R1 & R2. The operational logic of the IC's CE pin is selectable (please refer to the selection guide). Note that as the standard SSP9193 type's regulator 1 and 2 are both 'High Active/No Pull-Down', operations will become unstable with the CE pin open. Although the CE pin is equal to an inverter input with CMOS hysteresis, with either the pull-up or pull-down options, the CE pin input current will increase when the IC is in operation. We suggest that you use this IC with either a V_{IN} voltage or a V_{SS} voltage input at the CE pin. If this IC is used with the correct specifications for the CE pin, the operational logic is fixed and the IC will operate normally. However, supply current may increase as a result of through current in the IC's internal circuitry.

Notes on Use

1. Please use this IC within the stated absolute maximum ratings. The IC is liable to malfunction should the ratings be exceeded.
2. Where wiring impedance is high, operations may become unstable due to noise and/or phase lag depending on output current. Please keep the resistance low between V_{IN} and V_{SS} wiring in particular.
3. Please wire the input capacitor (C_{IN}) and the output capacitor (C_L) as close to the IC as possible.

Packaging Information
SOT23-5 Outline Dimensions

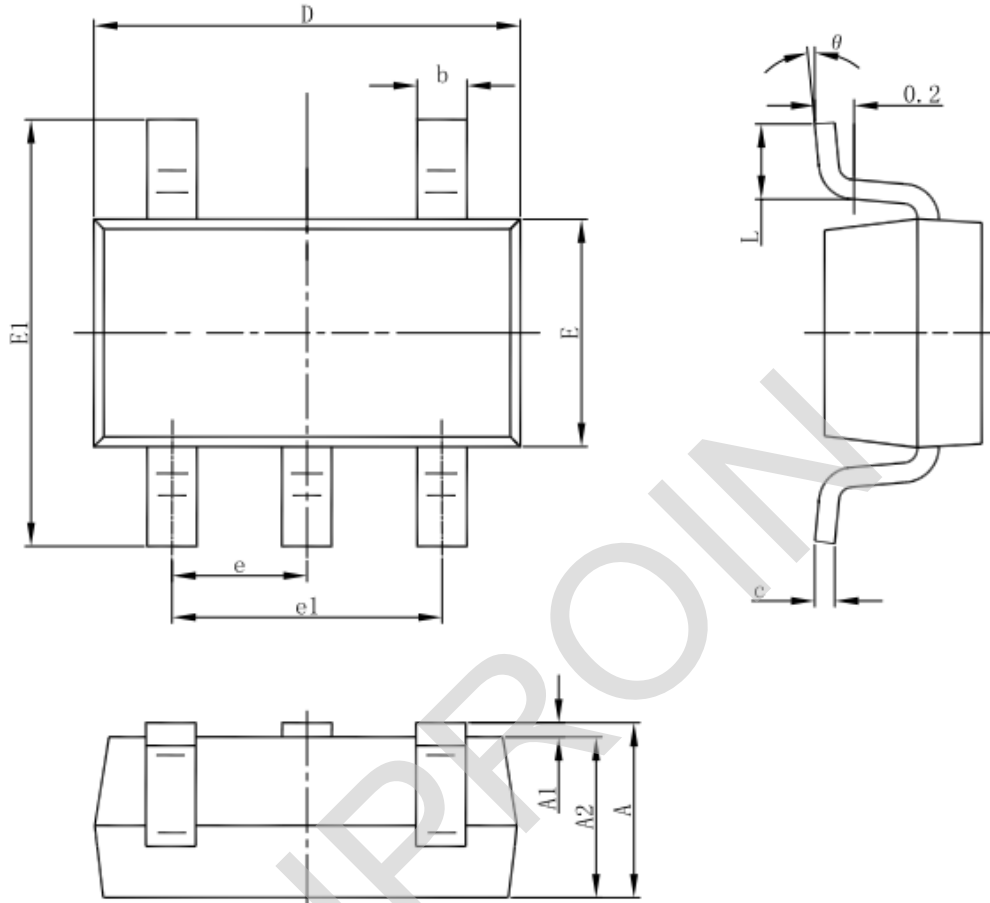

Symbol	Dimensions In Millimeters		Dimensions In Inches	
	Min	Max	Min	Max
A	1.050	1.250	0.041	0.049
A1	0.000	0.100	0.000	0.004
A2	1.050	1.150	0.041	0.045
b	0.300	0.500	0.012	0.020
c	0.100	0.200	0.004	0.008
D	2.820	3.020	0.111	0.119
E	1.500	1.700	0.059	0.067
E1	2.650	2.950	0.104	0.116
e	0.950(BSC)		0.037(BSC)	
e1	1.800	2.000	0.071	0.079
L	0.300	0.600	0.012	0.024
θ	0°	8°	0°	8°

X-ON Electronics

Largest Supplier of Electrical and Electronic Components

Click to view similar products for [LDO Voltage Regulators](#) category:

Click to view products by [Siproin](#) manufacturer:

Other Similar products are found below :

[M38D29FFHP#U1](#) [702103A](#) [717726C](#) [742457H](#) [MP20051DN-LF-Z](#) [R5F111PGGFB#30](#) [AP7363-SP-13](#) [NCP103AMX285TCG](#)
[NCV8664CST33T3G](#) [NCV8752AMX28TCG](#) [L9454](#) [AP7362-HA-7](#) [LX13043CLD](#) [TCR3DF185,LM\(CT](#) [TCR3DF24,LM\(CT](#)
[TCR3DF285,LM\(CT](#) [TCR3DF31,LM\(CT](#) [TCR3DF45,LM\(CT](#) [TLF4949EJ](#) [L9708](#) [L970813TR](#) [030014BB](#) [059985X](#) [EAN61387601](#)
[EAN61573601](#) [NCP121AMX173TCG](#) [NCP4687DH15T1G](#) [NCV8703MX30TCG](#) [701326R](#) [702087BB](#) [755078E](#) [TCR2EN28,LF\(S](#)
[LM1117DT-1.8/NO](#) [LT1086CM#TRPBF](#) [AZ1085S2-1.5TRE1](#) [MAX15101EWL+T](#) [NCV8170AXV250T2G](#) [SCD337BTG](#)
[TCR3DF27,LM\(CT](#) [TCR3DF19,LM\(CT](#) [TCR3DF125,LM\(CT](#) [TCR2EN18,LF\(S](#) [MAX15103EWL+T](#) [TS2937CZ-5.0 C0](#) [MAX8878EUK30-](#)
[T](#) [MAX663CPA](#) [NCV4269CPD50R2G](#) [NCV8716MT30TBG](#) [AZ1117IH-1.2TRG1](#) [MP2013GQ-P](#)