

**FEATURES**

- Supply voltages from 3 V to 5.5V
- Dual-channel
- 120kbps Data Rates
- 15kV HBM ESD-Protected
- 8kV IEC-4100-4-2 Contact Discharge

**OUTLINE**



Provide green and environmentally friendly lead-free package

**DESCRIPTION**

SIT3232E is a 3.3V-power-supply, dual-channel,high ESD-protected, low-power RS-232 transceiver that fully meets the requirements of the TIA/EIA-232 standard.

SIT3232E includes two drives and two receivers,with enhanced ESD protection function, reaching the protection capacity of HBM ESD above 15kV and 8kV IEC-4100-4-2 contact discharge.

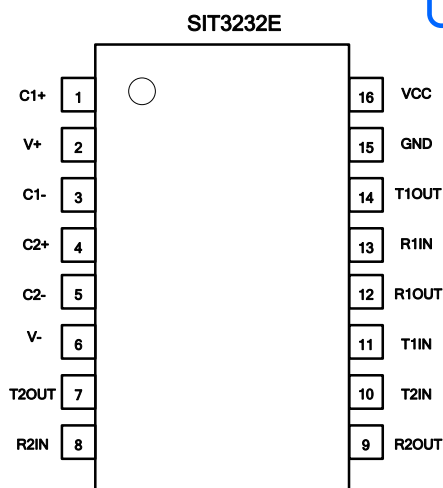
Powered by 3.3V power supply, The charge pump requires only four 1 $\mu$ F external capacitance to work at a rate of at least 120Kbps error-free data transmission, both of which can be independently enabled and closed. Each driver and receiver can be used independently.

**PIN CONFIGURATION**

**LIMITING VALUES**

PARAMETER	SYMBOL	VALUE	UNIT
Supply voltage	VCC	-0.3~+6	V
Doubled Voltage Terminal	V+	VCC-0.3~+7	V
Inverted Voltage Terminal	V-	+0.3~-7	V
$V+ +  V- $		+13	V
Transmitter Input Voltage Range	T1IN,T2IN	-0.3~+6	V
Receiver Input Voltage Range	R1IN,R2IN	±25	V
Transmitter Output Voltage Range	T1OUT,T2OUT	±13.2	V
Receiver Output Voltage Range	R1OUT,R2OUT	-0.3~VCC+0.3	V
Operating Temperature		-40~85	°C
Storage Temperature		-60~150	°C
Soldering Temperature		300	°C
Continuous Power	SOP16	760	mW
	DIP16	840	mW

The maximum limit parameters means that exceeding these values may cause irreversible damage to the device. Under these conditions, it is not conducive to the normal operation of the device. The continuous operation of the device at the maximum allowable rating may affect the reliability of the device. The reference point for all voltages is ground.

**PINNING**

PIN	SYMBOL	DESCRIPTION
1	C1+	Positive Terminal for the first Charge Pump Capacitor
2	V+	Doubled Voltage Terminal
3	C1-	Negative Terminal for the first Charge Pump Capacitor
4	C2+	Positive Terminal for the second Charge Pump Capacitor
5	C2-	Negative Terminal for the second Charge Pump Capacitor
6	V-	Inverted Voltage Terminal
7	T2OUT	Second Transmitter Output Voltage

8	R2IN	Second Receiver Input Voltage
9	R2OUT	Second Receiver Output Voltage
10	T2IN	Second Transmitter Input Voltage
11	T1IN	First Transmitter Input Voltage
12	R1OUT	First Receiver Output Voltage
13	R1IN	First Receiver Input Voltage
14	T1OUT	First Transmitter Output Voltage
15	GND	Ground
16	VCC	Supply Voltage

### Supply Current

PARAMETER	SYMBOL	CONDITION	MIN.	TYP.	MAX.	UNIT
Supply Current with no Load	$I_{sup}$			2		mA

(If there is no additional explanation, typical value is tested when  $VCC=+3.3V$ ,  $Temp=25^{\circ}C$ ,  $C1-C4=1\mu F$ )

### Logic Input Electrical Characteristics

PARAMETER	SYMBOL	CONDITION	MIN.	TYP.	MAX.	UNIT
Logic Control Low Level	$V_{TIN\_L}$	T1IN, T2IN			0.8	V
Logic Control High Level	$V_{TIN\_H}$	T1IN, T2IN	2			V
Logic Control Hysteresis		T1IN, T2IN		0.3		V
Input Logic Current	$I_{TIN}$	T1IN, T2IN			$\pm 1$	$\mu A$

(If there is no additional explanation, typical value is tested when  $VCC=+3.3V$ ,  $Temp=25^{\circ}C$ ,  $C1-C4=1\mu F$ )

### Receiver Output Electrical Characteristics

PARAMETER	SYMBOL	CONDITION	MIN.	TYP.	MAX.	UNIT
Receiver Output Logic-Low Voltage	$V_{ROL}$	$I_{OUT}=1.6mA$ , $VCC=5V$ or $3.3V$			0.4	V

Receiver Output Logic-High Voltage	$V_{ROH}$	$I_{OUT}=-0.5mA$ , $VCC=5V$ or $3.3V$	$VCC-0.6$	$VCC-0.1$		V
------------------------------------	-----------	--	-----------	-----------	--	---

(If there is no additional explanation,typical value is tested when  $VCC=+3.3V$ ,Temp= $25^{\circ}C$ ,C1-C4= $1\mu F$ )

### Receiver Input Electrical Characteristics

PARAMETER	SYMBOL	CONDITION	MIN.	TYP.	MAX.	UNIT
Receiver Input Range	$V_{RIN}$		-25		+25	V
Receiver Input Low Threshold	$V_{RIL}$	$VCC=3.3V$	0.6	1.1		V
		$VCC=5V$	0.8	1.5		V
Receiver Input High Threshold	$V_{RIH}$	$VCC=3.3V$		1.5	2.4	V
		$VCC=5V$		1.9	2.4	V
Receiver Input Hysteresis				0.4		V
Receiver Input Impedance	$R_{RIN}$		3	5	7	k $\Omega$

(If there is no additional explanation,typical value is tested when  $VCC=+3.3V$ ,Temp= $25^{\circ}C$ ,C1-C4= $1\mu F$ )

### Transmitter Output Electrical Characteristics

PARAMETER	SYMBOL	CONDITION	MIN.	TYP.	MAX.	UNIT
Transmitter Output Swing	$V_{TOUT}$	All output ports of transmitter connect $3k\Omega$ load to ground	$\pm 4$		$\pm 5$	V
Transmitter Output Impedance	$R_{TOUT}$	$VCC=0V$ , Transmitter Input= $\pm 2V$	300			$\Omega$
Transmitter Short-Circuit Current	$I_{TSC}$				60	mA

(If there is no additional explanation,typical value is tested when  $VCC=+3.3V$ ,Temp= $25^{\circ}C$ ,C1-C4= $1\mu F$ )

**ESD protection**

PARAMETER	SYMBOL	CONDITION	MIN.	TYP.	MAX.	UNIT
R1IN、R2IN T1OUT、T2OUT		HBM		±15		KV
		Air Discharge		±15		KV
		Contact Discharge		±8		KV

**Switching Characteristics Parameter**

PARAMETER	SYMBOL	CONDITION	MIN.	TYP.	MAX.	UNIT
Rate	Speed	RL=3kΩ, CL=1000pF		120		kbps
Receiver Propagation delay	t <sub>RPHL</sub>	CL=150pF		300		ns
	t <sub>RPLH</sub>			300		ns
	t <sub>RPHL</sub> - t <sub>RPLH</sub>			150		ns
	t <sub>TPHL</sub> - t <sub>TPLH</sub>			150		ns
Transmitter Slew Rate	SR	RL=3kΩ~7kΩ, CL=150pF~1000pF from-3.0V~3.0V or from3.0V~-3.0V See figures 2 and 3	4		30	V/μs

(If there is no additional explanation,typical value is tested when VCC=+3.3V,Temp=25°C,C1-C4=1μF)

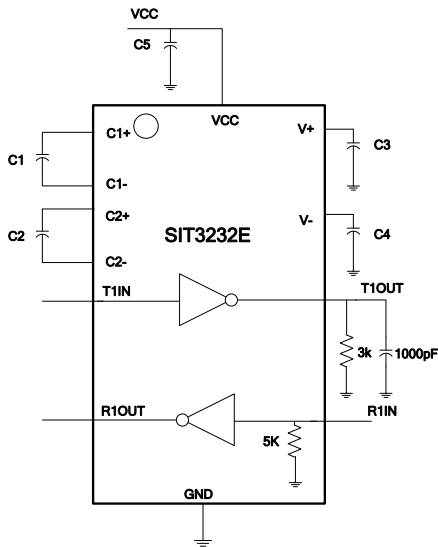
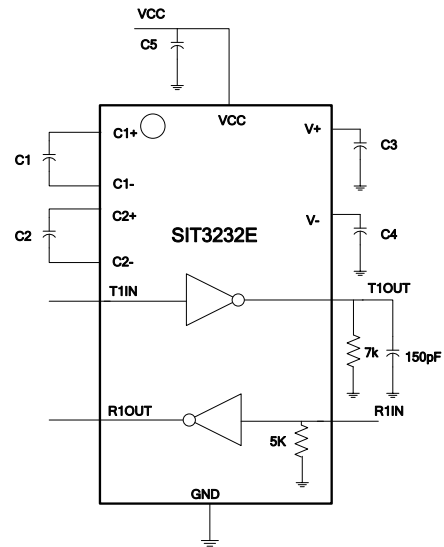
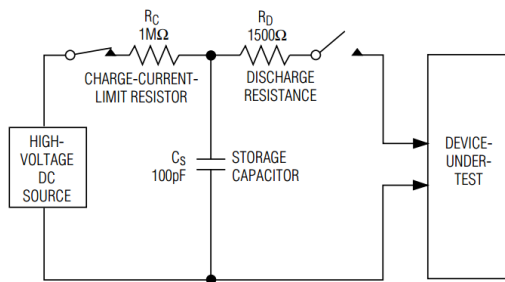
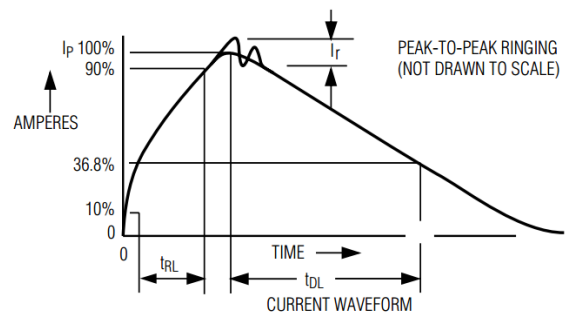
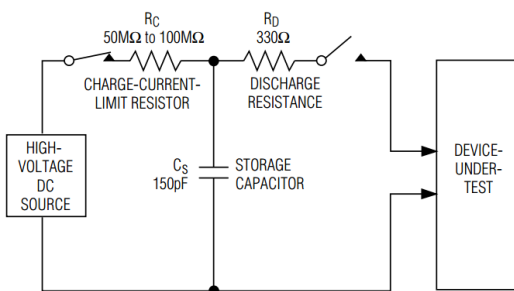
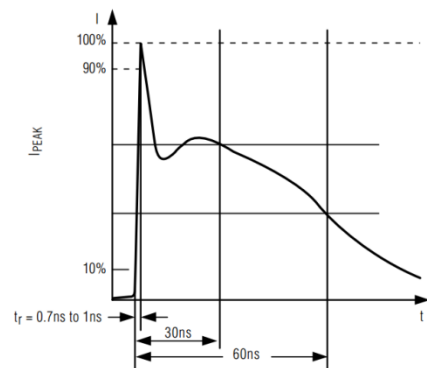
**TEST CIRCUIT**

**Figure 2 minimum swing rate test circuit**

**Figure 3 maximum swing rate test circuit**

**Figure 4 ESD test model of human body mode**

**Figure 5 human body mode current waveform**

**Figure 6 ESD test model of IEC 1000-4-2**

**Figure 7 current waveform of IEC 1000-4-2 ESD**

**ADDITIONAL DESCRIPTION**
**1 Dual Charge-Pump Operation**

SIT3232E has a two-way charge pump inside to support the chip's voltage conversion work. Dual-electric pump provides +5.5V and -5.5V output voltage in the range of 3.0 ~ 5.5V, Each charge pump requires a capacitor(C1,C2) and an energy storage capacitor(C3,C4) to generate V+ and V-power supplies, as shown in Fig 8.

**2 RS232 Transmitter**

Convert the TTL/CMOS logic voltage to a voltage compatible with the EIA/TIA-232 standard. SIT3232E Transmitter can guarantee 120kbps data rate under the worst operating conditions (Parallel load of 3kΩ resistor and 1000pf capacitor). Transmitter can drive multiple receivers in parallel. There is no pull-up resistance inside the input terminals T1IN and T2IN of SIT3232E transmitter. If the transmitter is not used, the unused input terminals T1IN and T2IN can be connected to GND or VCC.

**3 RS232 Receiver**

The SIT3232E has two separate receivers that convert the RS-232 signal to the CMOS logic output level.

**4 ESD Protection**

All pins of SIT3232E adopt ESD protection structure, and all driver outputs and receiver inputs have additional electrostatic protection capability. It can withstand ±15kV ESD (HBM) discharge, contact discharge above ±8KV and air gap discharge above ±15kV. The ESD protection structure can withstand the impact of high voltage ESD under all conditions, including standard working mode and power-off mode.

**5 Typical Application**

Typical dual-Path application scenarios are shown in Figure 8, where the C1-C5 typical capacitance value is 0.1μF.

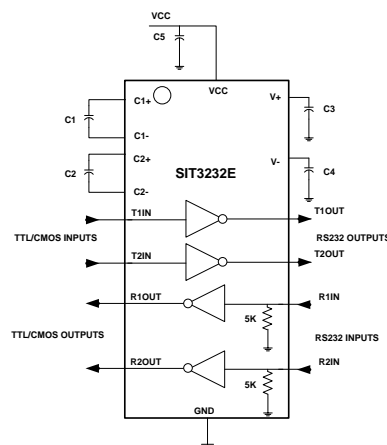
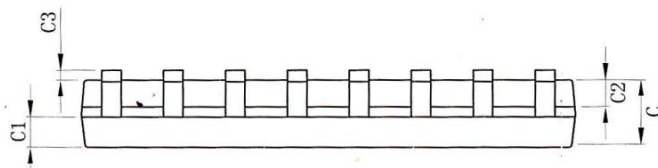
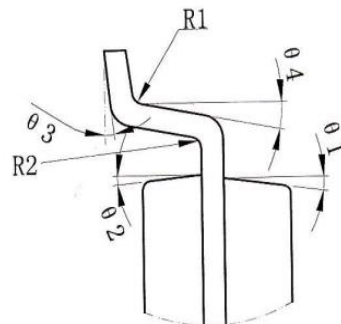
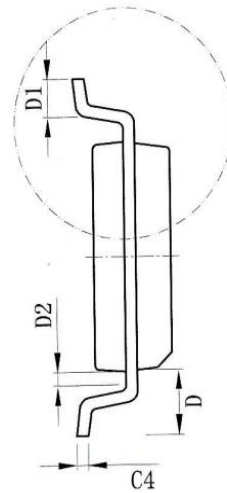
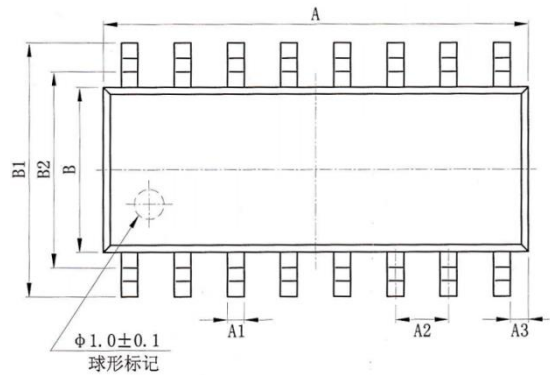

Figure 8 Typical dual-Path application scenarios

**SOP16 DIMENSIONS**
**PACKAGE SIZE**

SIZE SYMBOL	MIN./mm	MAX./mm
A	9.80	10.00
A1	0.356	0.456
A2	1.27TYP	
A3	0.302TYP	
B	3.85	3.95
B1	5.84	6.24
B2	5.00 TYP	
C	1.40	1.60
C1	0.61	0.71
C2	0.54	0.64
C3	0.05	0.25
C4	0.203	0.233
D	1.05 TYP	
D1	0.40	0.70
D2	0.15	0.25
R1	0.20TYP	
R2	0.20TYP	
θ1	8°~12°TYP4	
θ2	8°~12°TYP4	
θ3	0°~8°	
θ4	4°~12°	





**SSOP16(0.65) DIMENSIONS**
**PACKAGE SIZE**

SIZE SYMBOL	MIN/mm	MAX/mm
A	6.15	6.25
A1	0.30TYP	
A2	0.65TYP	
A3	0.675TYP	
B	5.25	5.35
B1	7.65	7.95
B2	0.60	0.80
C	1.70	1.80
C1	1.75	1.95
C2	0.799	
C3	0.152	
C4	0.172	
H	0.05	0.15
$\theta$	12°TYP4	
$\theta 1$	12°TYP4	
$\theta 2$	10°TYP	
$\theta 3$	0°~8°	
R	0.20°TYP	
R	0.15°TYP	

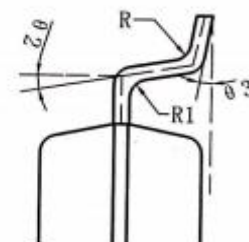
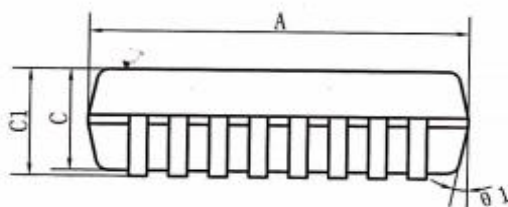
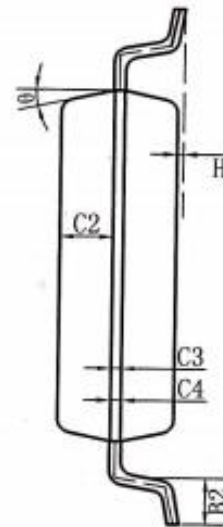
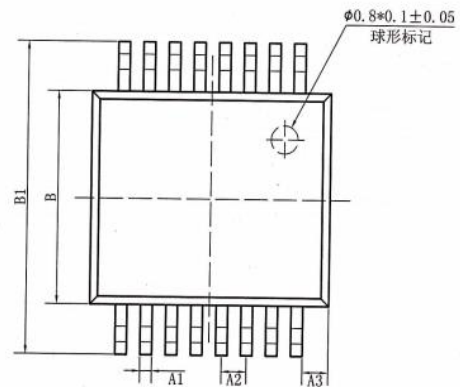

**TSSOP16 DIMENSIONS**
**PACKAGE SIZE**

SIZE SYMBOL	MIN./mm	TYP./mm	MAX./mm
A	--	--	1.20
A1	0.05		0.15
A2	0.90	1.00	1.05
b	0.20	--	0.30
b1	0.19	0.22	0.25
c	0.110	0.127	0.145
c1	0.12	0.13	0.14
D	4.86	4.96	5.06
E	6.20	6.40	6.60
E1	4.30	4.40	4.50
e	0.65BSC		
L	0.45	0.60	0.75
L1	1.00BSC		
	0°	--	8°

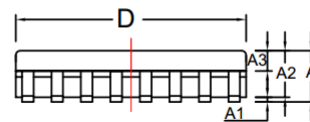
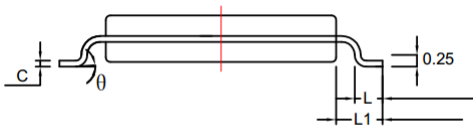
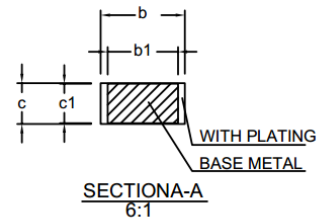
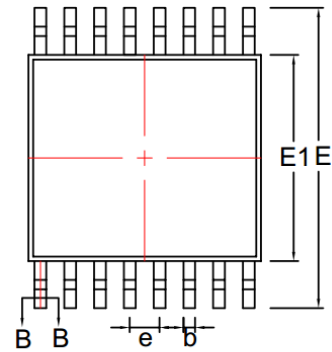

**SOPW16 DIMENSIONS**
**封装尺寸**

标注	尺寸	最小值/mm	最大值/mm
A	-	-	2.65
A1	-	0.10	0.30
A2	-	2.25	2.35
A3	-	0.97	1.07
D	-	10.10	10.50
E	-	10.26	10.60
E1	-	7.30	7.70
e	1.27BSC		
L	-	0.55	0.85
L1	1.4BSC		
H	-	0.345	0.365
R	0.20TYP		
R1	0.30TYP		
$\theta$	-	0°	8°
$\theta_1$	45°TYP		
$\theta_2$	12°TYP		
$\theta_3$	-	0°	8°
$\theta_4$	-	0°	10°

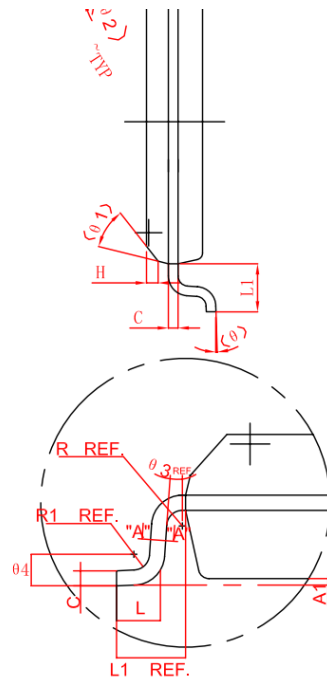
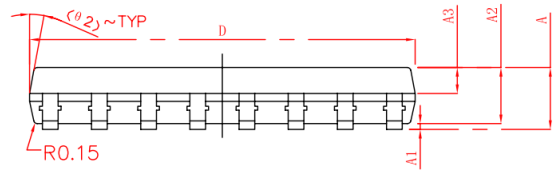
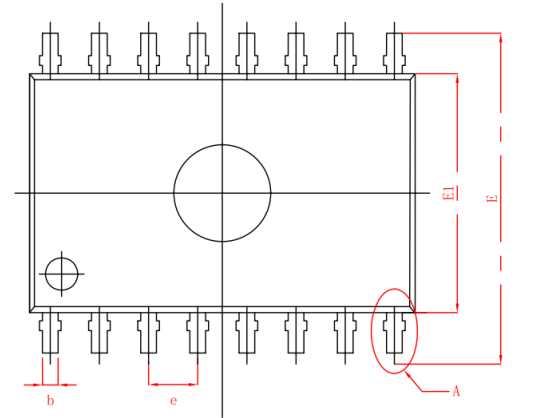

**ORDERING INFORMATION**

TYPE NUMBER	TEMPERATURE	PACKAGE
SIT3232EESE	-40°C~85°C	SOP16
SIT3232EEAE	-40°C~85°C	SSOP16
SIT3232EEUE	-40°C~85°C	TSSOP16
SIT3232EEWE	-40°C~85°C	WSOP16 Wide body

The tapered package of SIT3232EESE , SIT3232EEUE is 2500 pieces/disc.

## X-ON Electronics

Largest Supplier of Electrical and Electronic Components

*Click to view similar products for [RS-232 Interface IC category](#):*

*Click to view products by [SIT manufacturer](#):*

Other Similar products are found below :

[062191EB](#) [CH438L](#) [MAX3386ECPWR](#) [ICL3232IVZ-T7A](#) [ICL3226ECA](#) [AZ75232GTR-G1](#) [TRS222IDWR](#) [MAX232INE4](#) [MAX3232CPW](#)  
[TRS3232EIDWR](#) [TRS3222EIPWR](#) [TRS3222ECPWR](#) [SN65C3232EDWR](#) [LT1039CN16#PBF](#) [LT1039ISW#PBF](#) [LT1281AISW#PBF](#)  
[LTC1337CSW#PBF](#) [LT1180ACN#PBF](#) [LT1130ACSW#PBF](#) [LTC1349ISW#PBF](#) [744224X](#) [LT1131ACNW](#) [LT1131ACSW](#) [LT1342CG](#)  
[SN65C3232DWR](#) [SN75188DE4](#) [601096C](#) [AD7306JNZ](#) [ADM3311EARSZ-REEL](#) [ADM202EARUZ-REEL](#) [ADM202EARUZ-REEL7](#)  
[ADM3202ARUZ-REEL7](#) [ADM3232EARUZ](#) [ADM3202ARUZ](#) [ADM101EARMZ-REEL](#) [ADM101EARMZ-REEL7](#) [ADM101EWARMZ-](#)  
[REEL7](#) [ADM202EANZ](#) [ADM202EARNZ](#) [ADM202EARNZ-REEL](#) [ADM202EARNZ-REEL7](#) [ADM202JNZ](#) [ADM202JRNZ](#)  
[ADM202JRNZ-REEL](#) [ADM202JRNZ-REEL7](#) [ADM206ARZ](#) [ADM207EANZ](#) [ADM207EARZ](#) [ADM208ARZ](#) [ADM208EARSZ](#)