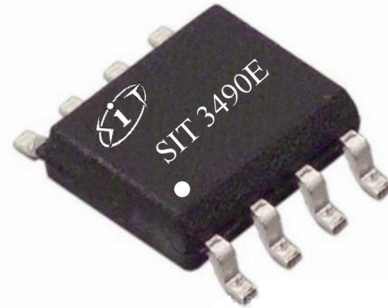

**FEATURES**

- 3.0V~5.5V Supply, Full-Duplex
- 1/8 Unit Load, Allow Up to 256 Transceivers on the Bus
- Driver Short-Circuit Output Protection
- Strong Anti-Noise Ability
- Integrated Transient Voltage Suppression Function
- The Data Transmission Rate Up to 14Mbps in Electric Noise Environment
- ESD Protection for RS-485 I/O Pins $\pm 15\text{kV}$, Human Body Model

OUTLINE

Provide green and environmentally friendly lead-free package

DESCRIPTION

SIT3490E is a 3.0V~5.5V powered, full-duplex, low power dissipation RS-485 transceiver fully meeting the requirements of RS-485/RS-422 standard.

SIT3490E contains one driver and one receiver, both can transmit signals independently. The SIT3490E has a 1/8-unit-load. It allows up to 256 transceivers on the bus and error-free data transmission up to 14Mbps.

SIT3490E has a working voltage range of 3.0V~5.5V, with the functions of Current-Limiting Protection, Over-voltage Protection, Control Port Hot Plug Input, etc.

SIT3490E has excellent ESD release capability, and HBM reaches $\pm 15\text{kV}$.

PIN CONFIGURATION

Figure.1 SIT3490E Pin Configuration

**LIMITING VALUES**

PARAMETER	SYMBOL	VALUE	UNIT
Supply voltage	VCC	+7	V
Driver Input Voltage	DI	-0.3~VCC+0.3	V
Receiver Input Voltage	A, B	-8~13	V
Receiver Output Voltage	RO	-0.3~VCC+0.3	V
Operating Temperature Ranges		-40~125	°C
Storage Temperature Range		-60~150	°C
Lead Temperature		300	°C
Continuous Power Dissipation	SOP8	400	mW
	DIP8	700	mW

The maximum limit parameters means that exceeding these values may cause irreversible damage to the device. Under these conditions, it is not conducive to the normal operation of the device. The continuous operation of the device at the maximum allowable rating may affect the reliability of the device. The reference point for all voltages is ground.

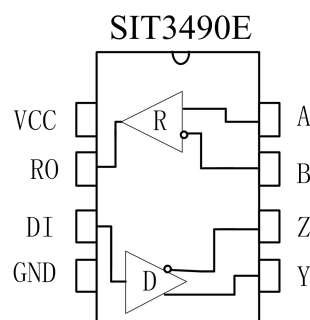
PINNING

PIN	SYMBOL	DESCRIPTION
1	VCC	Positive Supply: $3.0V \leq VCC \leq 5.5V$
2	RO	Receiver Output. If $A-B \geq +200mV$, RO will be high; If $A-B \leq -200mV$, RO will be low.
3	DI	Driver Input. A low on DI forces output Y low and output Z high. a high on DI forces output Y high and output Z low.
4	GND	Ground
5	Y	Non-inverting Driver Output
6	Z	Inverting Driver Output
7	B	Inverting Receiver Input
8	A	Non-inverting Receiver Input

**DRIVER DC ELECTRICAL CHARACTERISTICS**

PARAMETER	SYMBOL	CONDITION	MIN	TYP	MAX	UNIT
Differential Driver Output (No load)	V_{OD1}			5		V
Differential Driver Output	V_{OD2}	figure 2, $R_L = 27 \Omega$	1.5		VCC	V
		figure 2, $R_L = 50 \Omega$	2		VCC	
Change in Magnitude of Driver Differential Output Voltage (NOTE1)	ΔV_{OD}	figure 2, $R_L = 27 \Omega$			0.2	V
Driver Common-Mode Output Voltage	V_{OC}	figure 2, $R_L = 27 \Omega$			3	V
Change in Magnitude of Common-Mode Output Voltage (NOTE1)	ΔV_{OC}	figure 2, $R_L = 27 \Omega$			0.2	V
Input High Voltage	V_{IH}	DI	2.0			V
Input Low Voltage	V_{IL}	DI			0.8	V
Logic Input Current	I_{IN1}	DI	-2		2	μA
Output short-circuit current, short-circuit to high	I_{OSD1}	short-circuit to 0V~12V	35		250	mA
Output short-circuit current, short-circuit to low	I_{OSD2}	short-circuit to 7V~0V	-250		-35	mA

(Unless otherwise noted, $V_{CC}=3.3V \pm 10\%$, $Temp=T_{MIN} \sim T_{MAX}$, Typical values are at $V_{CC}=+3.3V$, $Temp=25^{\circ}C$)

NOTE1: ΔV_{OD} and ΔV_{OC} are the changes in V_{OD} and V_{OC} , respectively, when the DI input changes state.

RECEIVER DC ELECTRICAL CHARACTERISTICS

PARAMETER	SYMBOL	CONDITION	MIN	TYP	MAX	UNIT
Input current (A, B)	I_{IN2}	$V_{CC}=0$ or $3.3V$ $V_{IN} = 12V$			125	μA



		VCC=0 or 3.3V V _{IN} = -7 V	-100			μA
Positive input threshold voltage	V _{IT+}	-7V ≅ V _{CM} ≅ 12V			+200	mV
Reverse input threshold voltage	V _{IT-}	-7V ≅ V _{CM} ≅ 12V	-200			mV
Input hysteresis voltage	V _{hys}	-7V ≅ V _{CM} ≅ 12V	10	30		mV
Receiver Output High Voltage	V _{OH}	I _{OUT} = -4mA, V _{ID} = +200 mV	VCC-1.5			V
Receiver Output Low Voltage	V _{OL}	I _{OUT} = +4mA, V _{ID} = -200 mV			0.4	V
Three-State Output Current at Receiver	I _{OZR}	0.4 V < V _O < 2.4 V			±1	μA
Receiver Input Resistance	R _{IN}	-7V ≅ V _{CM} ≅ 12V	96			kΩ
Receiver Short-Circuit Output Current	I _{OSR}	0 V ≤ V _O ≤ VCC	±7		±95	mA

(Unless otherwise noted, VCC=3.3V±10%, Temp=T_{MIN}~T_{MAX}, Typical values are at VCC=+3.3V, Temp=25°C)

SUPPLY CURRENT

PARAMETER	SYMBOL	CONDITION	MIN	TYP	MAX	UNIT
Supply Current	I _{CC}	DI=0 or VCC		240	400	μA

ESD PROTECTION

PARAMETER	SYMBOL	CONDITION	MIN	TYP	MAX	UNIT
A, B, Y, Z		HBM		±16		KV
Other ports		HBM		±6		KV

**DRIVER SWITCHING CHARACTERISTICS**

PARAMETER	SYMBOL	CONDITION	MIN	TYP	MAX	UNIT
Driver Propagation Delay, Low-to-High Level	t _{DPLH}	R _{DIFF} = 54 Ω, C _{L1} =C _{L2} =100pF (figure3 & figure4)		15	35	ns
Driver Propagation Delay, High-to-Low Level	t _{DPHL}			15	35	ns
t _{DPLH} - t _{DPHL}	t _{SKEW1}			7	10	ns
Rising time /Falling time	t _{DR} , t _{DF}			10	25	ns

RECEIVER SWITCHING CHARACTERISTICS

PARAMETER	SYMBOL	CONDITION	MIN	TYP	MAX	UNIT
Receiver Propagation Delay,Low-to-High Level	t _{RPLH}	figure 5 & figure 6 V _{ID} ≥2.0V; Rising and falling edge time V _{ID} ≤15ns	20	60	90	ns
Receiver Propagation Delay,High-to-Low Level	t _{RPHL}		20	60	90	ns
t _{RPLH} - t _{RPHL}	t _{SKEW2}		7	10	ns	

FUNCTION TABLE**Driver Function**

INPUT	OUTPUT	
DI	Y	Z
1	H	L
0	L	H
-	-	-

Receiver Function

INPUT	OUTPUT
A-B	RO
≥+200mV	H
≤-200mV	L
Open/Short	H

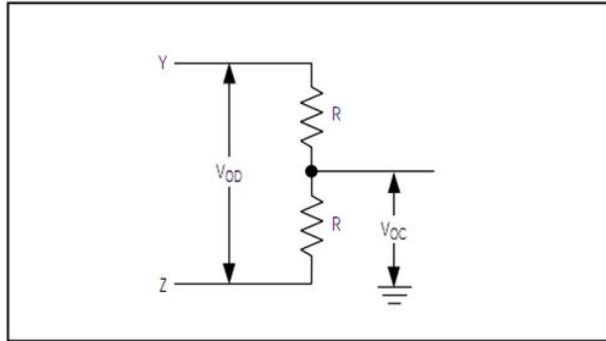
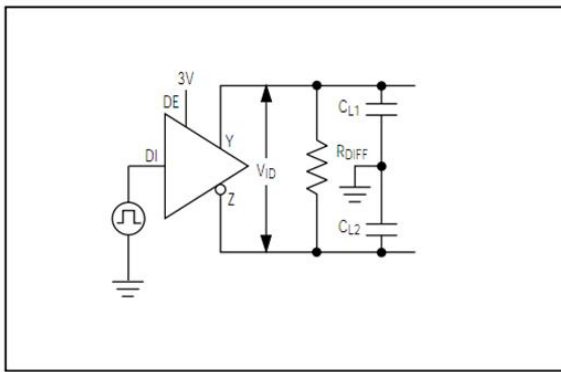
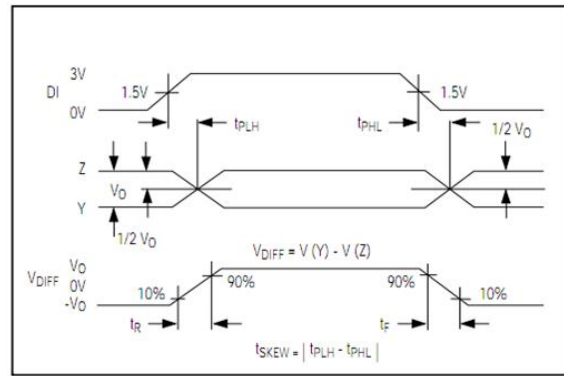
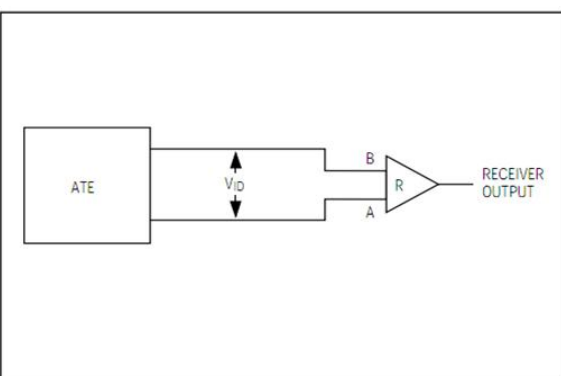
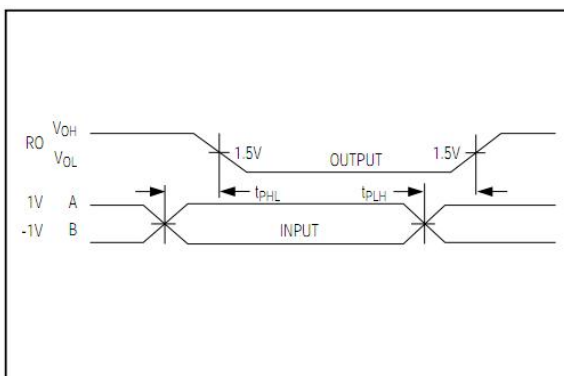
TEST CIRCUIT

Figure 2 Driver DC test load

Figure 3 Driver timing test circuit

Figure 4 Drive propagation delay

Figure 5 Receiver propagation delay test circuit

Figure 6 Receiver propagation delay timing



ADDITIONAL DESCRIPTION

1 Sketch

SIT3490E is a full-duplex high-speed transceiver for RS-485 / RS-422 communication, which includes a driver and a receiver. It has failure safety, over-voltage protection and over-current protection. SIT3490E realizes error-free data transmission up to 14Mbps.

2 Allowing up to 256 transceivers on the bus

The input impedance of the standard RS485 receiver is $12k\Omega$ (1 unit load), and the standard driver can drive up to 32 unit loads. The receiver of SIT3490E transceiver has $1/8$ unit load input impedance ($96k\Omega$), which allows up to 256 transceivers to be connected on the same communication bus in parallel. These devices can be combined arbitrarily or with other RS485 transceivers. Any combination of these devices and/or other RS-485 transceivers with a total of 32 unit loads or less can be connected to the line.

3 Driver output protection

By means of over-current and over-voltage protection mechanism, it can prevent excessive output current and power dissipation caused by faults or by bus contention, and fast short-circuit protection can be provided in the whole common mode voltage range (refer to typical working characteristics).

SOP8 DIMENSIONS
PACKAGE SIZE

SYMBOL	MIN/mm	TYP/mm	MAX/mm
A	1.50	1.60	1.70
A1	0.1	0.15	0.2
A2	1.35	1.45	1.55
b	0.355	0.400	0.455
D	4.800	4.900	5.00
E	3.780	3.880	3.980
E1	5.800	6.000	6.200
e		1.270BSC	
L	0.40	0.60	0.80
c	0.153	0.203	0.253
θ	-2°	-4°	-6°

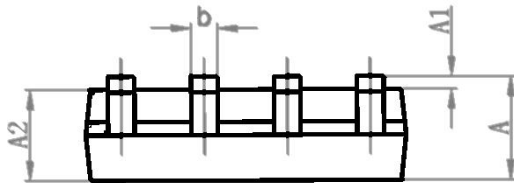
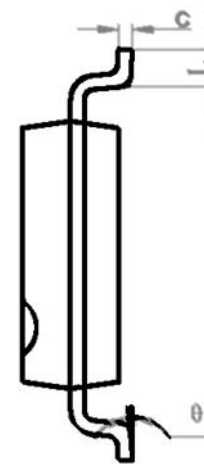
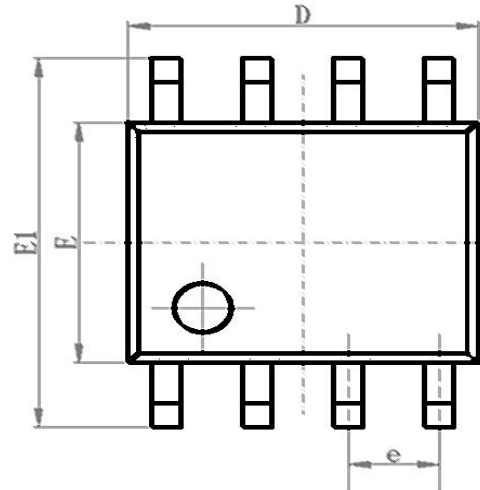



DIP8 DIMENSIONS

PACKAGE SIZE

SYMBOL	MIN/mm	TYP/mm	MAX/mm
A	9.00	9.20	9.40
A1	0.33	0.45	0.51
A2	2.54TYP		
A3	1.525TYP		
B	8.40	8.70	9.10
B1	6.20	6.40	6.60
B2	7.32	7.62	7.92
C	3.20	3.40	3.60
C1	0.50	0.60	0.80
C2	3.71	4.00	4.31
D	0.20	0.28	0.36
L	3.00	3.30	3.60

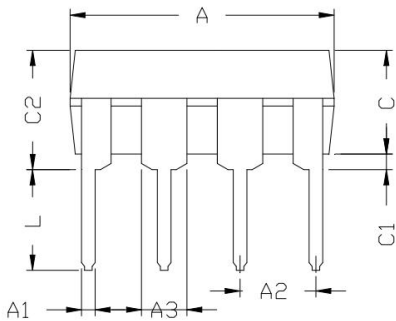
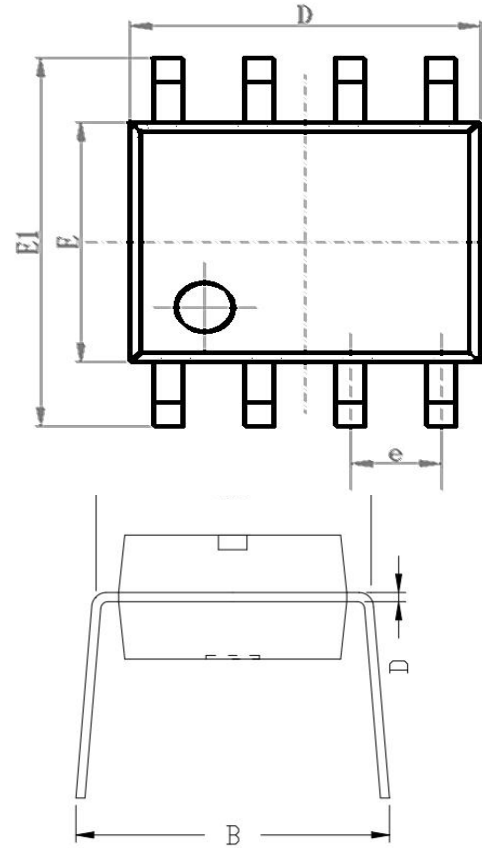



MSOP8 /8μMAX / VSSOP8 DIMENSIONS

PACKAGE SIZE

SYMBOL	MIN./mm	TYP./mm	MAX./mm
A	2.90	3.0	3.10
A1	0.28		0.35
A2	0.65TYP		
A3	0.375TYP		
B	2.90	3.0	3.10
B1	4.70		5.10
B2	0.45		0.75
C	0.75		0.95
C1			1.10
C2	0.328 TYP		
C3	0.152		
C4	0.15		0.23
H	0.00		0.09
θ	12°TYP		

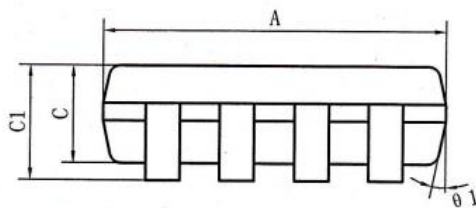
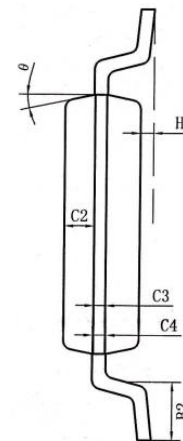
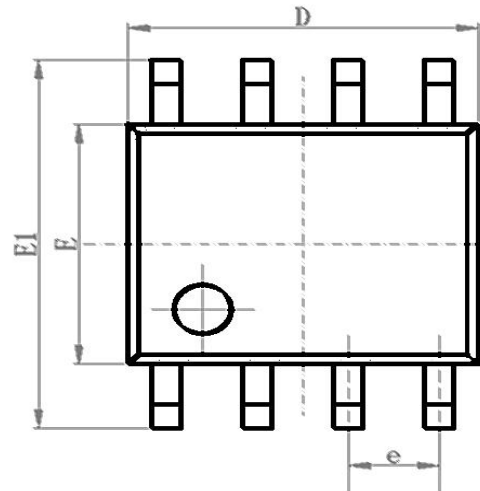

ORDERING INFORMATION

TYPE NUMBER	TEMPERATURE	PACKAGE
SIT3490EESA	-40°C~125°C	SOP8
SIT3490EEPA	-40°C~125°C	DIP8
SIT3490EEUA	-40°C~125°C	MSOP8/VSSOP8/8μMAX

Tapered package is 2500 pieces/disc.

X-ON Electronics

Largest Supplier of Electrical and Electronic Components

Click to view similar products for [RS-422/RS-485 Interface IC category](#):

Click to view products by [SIT manufacturer](#):

Other Similar products are found below :

[402824F](#) [702835FB](#) [MAX488ECPA](#) [MAX3491CSDT](#) [MAX3490AEGSA+](#) [MAX3483AEASA+](#) [MAX3491EESDT](#) [MAX3488AEGSA+](#)
[MAX3083CSD](#) [MAX487CSA](#) [SP3071EEN-L](#) [SP3072EEN-L/TR](#) [SP3075EEN-L](#) [SP3075EEN-L/TR](#) [SP3077EEN-L](#) [SP3078EEN-L](#)
[SP3078EEN-L/TR](#) [SP3082EEN-L](#) [SP3088EEN-L](#) [SP3483CN-L](#) [SP3483CN-L/TR](#) [SP3483EN-L](#) [SP3485CN-L](#) [SP3485CN-L/TR](#) [SP3485EN-](#)
[L](#) [SP3485EN-L/TR](#) [SP3490EN-L](#) [SP3494EN-L](#) [SP481EEN-L/TR](#) [SP483EN-L/TR](#) [SP490EEN-L/TR](#) [SP491EN-L/TR](#) [XR3078XID-F](#)
[SP3082EEN-L/TR](#) [SP330EEY-L/TR](#) [MAX14783EATA+T](#) [MAX3098EBCEE+T](#) [MAX3045BESE+T](#) [MAX22501EATA+T](#)
[MAX22502EATC+T](#) [MAX3042BCSE+T](#) [SP3077EEN-L/TR](#) [MAX487ESA+TCBX](#) [MAX1483CUA+T](#) [MAX487CUA+T](#) [CA-IS3082W](#) [CA-](#)
[IS3088W](#) [SP3074EEN-L/TR](#) [SP3483EN-L/TR](#) [NSI83085](#)