

# **SK hynix e-NAND Product Family** **eMMC5.1 Compatible**

## **Revision History**

<b>Revision No.</b>	<b>History</b>	<b>Date</b>	<b>Remark</b>
0.1	- Preliminary	May. 29, 2017	
1.0	- Official release	Sep. 07, 2017	

## Table of Contents

<b>1. Introduction</b>	<b>4</b>
1.1 General Description	4
1.2 Product Line-up	4
1.3 Key Features	4
<b>2. Package Configurations</b>	<b>5</b>
2.1 Pin connection	5
2.2 Package Mechanical Drawing	7
<b>3. e-NAND Characteristics</b>	<b>9</b>
3.1 Performance	9
3.2 Power	10
<b>4. e-NAND new features (eMMC5.0 and eMMC5.1)</b>	<b>12</b>
<b>4.1 eMMC5.0 New features</b>	<b>12</b>
4.1.1 HS400 mode	12
4.1.2 Field firmware update	19
4.1.3 Health Report	22
4.1.4 Sleep Notification	23
4.1.5 Secure Removal type	24
<b>4.2 eMMC5.1 New features</b>	<b>25</b>
4.2.1 Command queuing	25
4.2.2 Cache Barrier	29
4.2.3 Cache Flushing report	31
4.2.4 Background operation(BKOP) control	31
4.2.5 Secure Write Protection	32
4.2.6 Enhanced strobe	37
4.2.7 RPMB throughput improvement	41
<b>4.3 Enhanced features from eMMC4.5 to eMMC5.1</b>	<b>42</b>
<b>5. e-NAND general parameters</b>	<b>43</b>
5.1 Timing	43
5.2 Bus signal	48
5.3 Power mode	52
5.4 Connection guide	55
<b>6. e-NAND basic operations</b>	<b>56</b>
6.1 Partitioning	56
6.2 Boot operation	59
<b>7. Timeout</b>	<b>60</b>
<b>8. Register</b>	<b>62</b>
8.1 Operation conditions register (OCR)	62
8.2 Card identification (CID) register	63
8.3 Card specific data register(CSD)	64
8.4 Extended CSD register	66
8.5 RCA (Relative Card Address)	72
8.6 DSR (Driver Stage Register)	72

## 1. Introduction

### 1.1 General Description

SK Hynix e-NAND is compatible with JEDEC standard eMMC5.1 specifications.

e-NAND has the built-in intelligent controller which manages interface protocols, wear leveling, bad block management, garbage collection, and ECC.

e-NAND protects the data contents from the host sudden power off failure.

### 1.2 Product Line-up

Density	Part Number	NAND Stack	PKG Size (mm)	Package Type
16GB	H26M51002KPR	128Gb x 1	11.5x13x0.8	153FBGA
32GB	H26M62002JPR	128Gb x 2	11.5x13x0.8	
64GB	H26M74002HMR	128Gb x 4	11.5x13x1.0	

### 1.3 Key Features

- **eMMC5.1 compatible**

(Backward compatible to eMMC4.5&eMMC5.0)

- **Bus mode**

- Data bus width : 1bit(default), 4bits, 8bits
- Data transfer rate: up to 400MB/s (HS400)
- MMC I/F Clock frequency : 0~200MHz
- MMC I/F Boot frequency : 0~52MHz

- **Operating Voltage Range**

- V<sub>cc</sub> (NAND) : 2.7V - 3.6V
- V<sub>ccq</sub> (Controller) : 1.7V - 1.95V

- **Temperature**

- Operation (-25°C ~ +85°C)
- Storage without operation (-40°C ~ +85°C)

- **Others**

- This product is compliance with the RoHS directive

- **Supported Features**

- HS400, HS200
- HPI, BKOPS, BKOP operation control
- Packed CMD, CMD queuing
- Cache, Cache barrier, Cache flushing report
- Partitioning, RPMB, RPMB throughput improve
- Discard, Trim, Erase, Sanitize
- Write protect, Secure write protection
- Lock/Unlock
- PON, Sleep/Awake
- Reliable Write
- Boot feature, Boot partition
- HW/SW Reset
- Field Firmware Update
- Configurable driver strength
- Health(Smart) report
- Production state awareness
- Secure removal type
- Data Strobe pin, Enhanced data strobe

## 2. Package Configurations

### 2.1 Pin connection

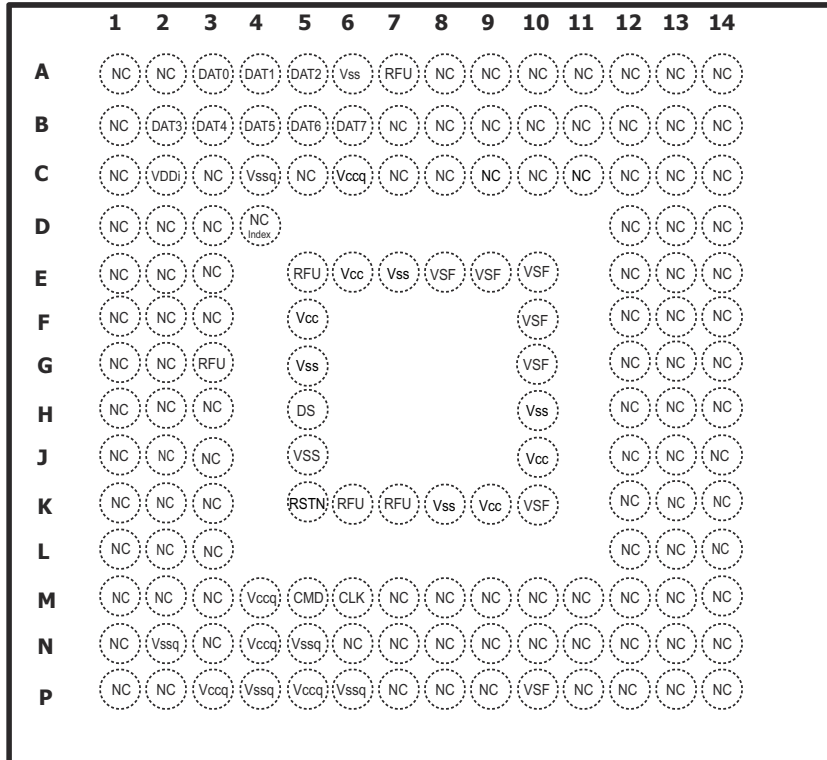

[Figure 1] 153 FBGA Ball Assignment

Pin number	Name	Pin number	Name	Pin number	Name	Pin number	Name
<b>A3</b>	DAT0	<b>C4</b>	V <sub>ssq</sub>	<b>G10</b>	VSF	<b>M5</b>	CMD
<b>A4</b>	DAT1	<b>C6</b>	V <sub>ccq</sub>	<b>H5</b>	DS	<b>M6</b>	CLK
<b>A5</b>	DAT2	<b>E6</b>	V <sub>cc</sub>	<b>H10</b>	V <sub>ss</sub>	<b>N2</b>	V <sub>ssq</sub>
<b>A6</b>	V <sub>ss</sub>	<b>E7</b>	V <sub>ss</sub>	<b>J5</b>	V <sub>ss</sub>	<b>N4</b>	V <sub>ccq</sub>
<b>B2</b>	DAT3	<b>E8</b>	VSF	<b>J10</b>	V <sub>cc</sub>	<b>N5</b>	V <sub>ssq</sub>
<b>B3</b>	DAT4	<b>E9</b>	VSF	<b>K5</b>	RSTN	<b>P3</b>	V <sub>ccq</sub>
<b>B4</b>	DAT5	<b>E10</b>	VSF	<b>K8</b>	V <sub>ss</sub>	<b>P4</b>	V <sub>ssq</sub>
<b>B5</b>	DAT6	<b>F5</b>	V <sub>cc</sub>	<b>K9</b>	V <sub>cc</sub>	<b>P5</b>	V <sub>ccq</sub>
<b>B6</b>	DAT7	<b>F10</b>	VSF	<b>K10</b>	VSF	<b>P6</b>	V <sub>ssq</sub>
<b>C2</b>	VDDi	<b>G5</b>	V <sub>ss</sub>	<b>M4</b>	V <sub>ccq</sub>	<b>P10</b>	VSF

Name	Type	Ball No.	Description
CLK	Input	M6	Clock: Each cycle directs a 1-bit transfer on the command and DAT lines.
CMD	Input	M5	Command: A bidirectional channel used for device initialization and command transfers. Command has two operating modes: 1) Open-drain for initialization. 2) Push-pull for fast command transfer.
DAT0	I/O	A3	Data I/O0: Bidirectional channel used for data transfer.
DAT1	I/O	A4	Data I/O1: Bidirectional channel used for data transfer.
DAT2	I/O	A5	Data I/O2: Bidirectional channel used for data transfer.
DAT3	I/O	B2	Data I/O3: Bidirectional channel used for data transfer.
DAT4	I/O	B3	Data I/O4: Bidirectional channel used for data transfer.
DAT5	I/O	B4	Data I/O5: Bidirectional channel used for data transfer.
DAT6	I/O	B5	Data I/O6: Bidirectional channel used for data transfer.
DAT7	I/O	B6	Data I/O7: Bidirectional channel used for data transfer.
RSTN	Input	K5	Reset signal pin
V <sub>CC</sub>	Supply	E6,F5,J10,K9	V <sub>CC</sub> : Flash memory I/F and Flash memory power supply.
V <sub>CCQ</sub>	Supply	C6,M4,N4,P3,P5	V <sub>CCQ</sub> : Memory controller core and MMC interface I/O power supply.
V <sub>SS</sub>	Supply	A6,E7,G5,H10,J5,K8	V <sub>SS</sub> : Flash memory I/F and Flash memory ground connection.
V <sub>SSQ</sub>	Supply	C4,N2,N5,P4,P6	V <sub>SSQ</sub> : Memory controller core and MMC I/F ground connection
VDDi		C2	VDDi: Connect 0.1μF capacitor from VDDi to ground.
DS	Out put	H5	DS: Data Strobe
VSF	Supply	E8,E9,E10,F10, G10, K10, P10	VSF: Vendor Specific Function SK hynix use E9, E10 Pin as VSF Pin
RFU			Reserved for future use

**[Table 1] 153 FBGA Ball Description**

## 2.2 Package Mechanical Drawing

### 2.2.1 11.5mm x13.0mm x0.8mm

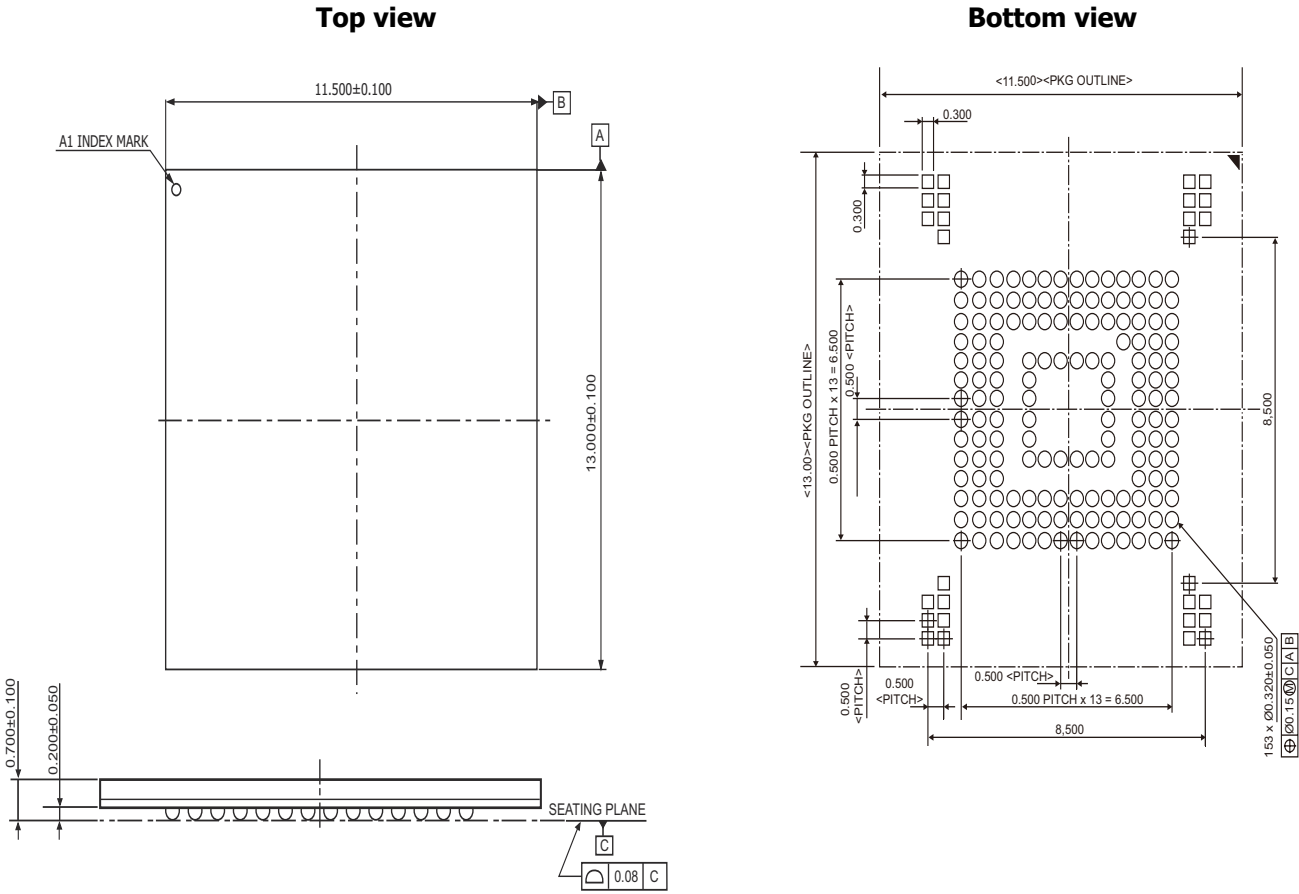

[Figure 2] 11.5mm x 13.0mm x 0.8mm Package dimension

## 2.2.2 11.5mm x13.0mm x1.0mm

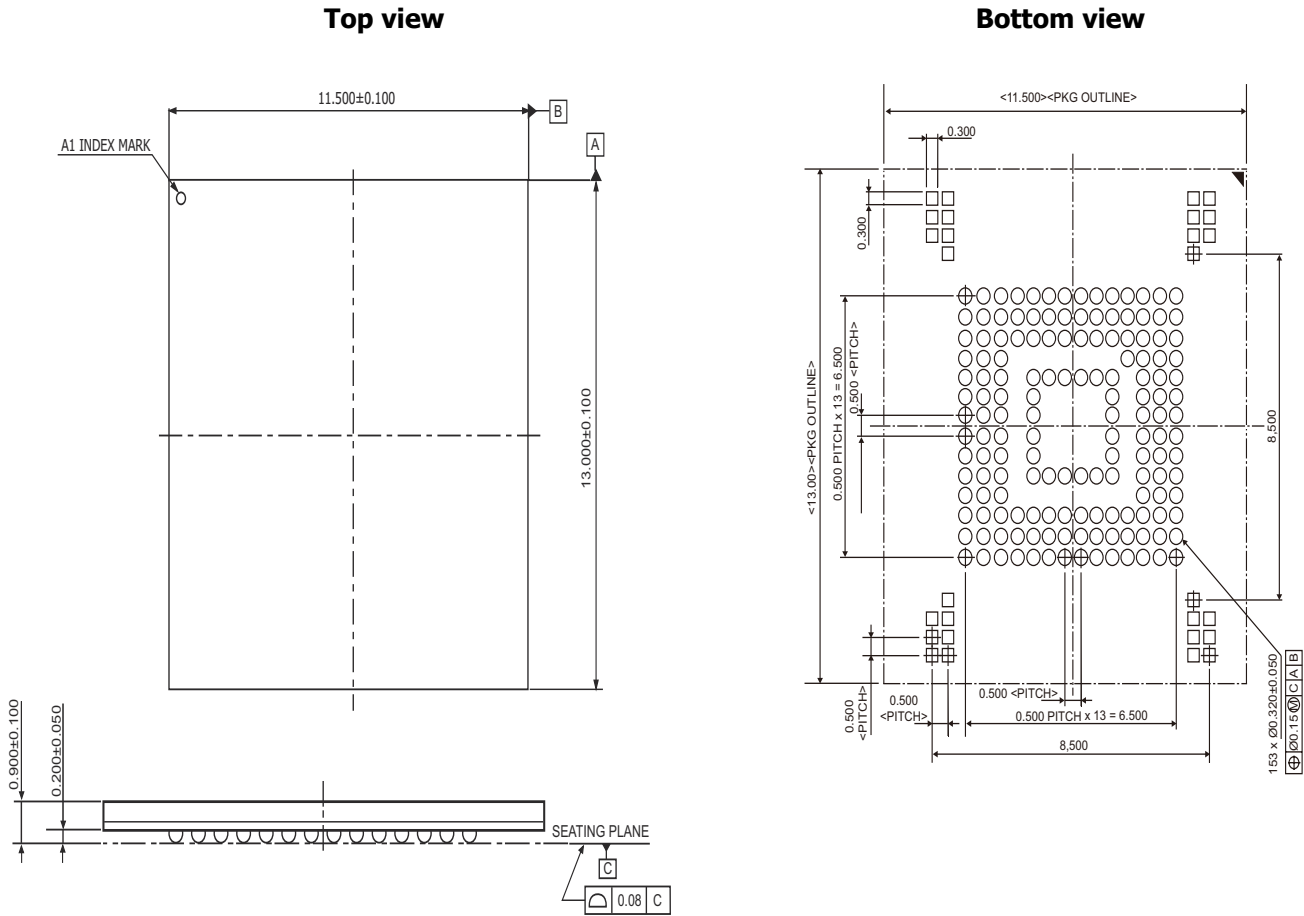

[Figure 3] 11.5mm x13.0mm x 1.0mm Package dimension



### 3. e-NAND Characteristics

#### 3.1 Performance

Density	Sequential Write (MB/s)	Sequential Read (MB/s)
16GB (SDP)	45	250
32GB (DDP)	90	280
64GB (QDP)	170	280

- Tool : Device level
- eMMC I/F speed : HS400
- Seq. chunk size : 512KB
- Adapted feature : Cache on
- Not 100% tested

## 3.2 Power

### 3.2.1 Active Power Consumption During Operation

Density		$I_{cc}$	$I_{ccq}$
16GB (SDP)	Avg. (mA)	50	200
	Peak (mA)	150	250
32GB (DDP)	Avg. (mA)	80	200
	Peak (mA)	150	250
64GB (QDP)	Avg. (mA)	140	200
	Peak (mA)	250	250

- Temperature : 25°C
- Average current consumption : over a period of 100ms
- Peak current consumption : averaged over a period of 20us
- Vcc : 3.3V
- Vccq : 1.8V
- Not 100% tested

### 3.2.2 Low Power Mode (Idle)

Density	Room Temperature (25°C)		Hot Temperature (85°C)	
	I <sub>CC</sub>	I <sub>CCQ</sub>	I <sub>CC</sub>	I <sub>CCQ</sub>
16GB (SDP)	Typ. 30uA	Typ. 120uA	Max. 50uA	Max. 500uA
32GB (DDP)	Typ. 60uA		Max. 100uA	
64GB (QDP)	Typ. 120uA		Max. 200uA	

- In Standby Power mode, CTRL V<sub>CCQ</sub> & NAND V<sub>CC</sub> power supply is switched on
- No data transaction period before entering sleep status
- Not 100% tested.

### 3.2.3 Low Power Mode (CMD5 Sleep)

Density	Room Temperature (25°C)		Hot Temperature (85°C)	
	I <sub>CC</sub>	I <sub>CCQ</sub>	I <sub>CC</sub>	I <sub>CCQ</sub>
16GB (SDP)	0	Typ. 120uA	0	Max. 500uA
32GB (DDP)				
64GB (QDP)				

- In Sleep state, triggered by CMD5, NAND V<sub>CC</sub> power supply is switched off (CTRL V<sub>CCQ</sub> on)
- Temperature : 25°C
- Not 100% tested.

## 4. e-NAND New features (eMMC5.0 and eMMC5.1)

### 4.1 eMMC5.0 New features

#### 4.1.1 HS400 mode

e-NAND supports HS400 signaling to achieve a bus speed of 400MB/s via a 200MHz DDR clock frequency. HS400 mode supports only 8-bit bus width and the 1.8V  $V_{CCQ}$ . Due to the speed, the host may need to have an adjustable sampling point to reliably receive the incoming data (Read Data and CRC Response) with DS pin. e-NAND supports up to 5 Driver Strength.

Driver type values	Support	Nominal Impedance	Approximated driving capability compared to Type_0	Remark
0	Mandatory	50Ω	x 1	Default Driver Type. Supports up to 200MHz operation.
1	Optional	33Ω	x 1.5	Supports up to 200MHz operation.
2		66Ω	x 0.75	The weakest driver that supports up to 200MHz operation.
3		100Ω	x 0.5	For low noise and low EMI systems. Maximal operating frequency is decided by host design.
4		40Ω	x 1.2	

[Table 2] I/O Driver strength types

Selecting **HS\_Timing** depends on Host I/F speed, default is 0, but all of value can be selected by host.

Value	Timing	Supportability for e-NAND
0x00	Selecting backward compatibility interface timing	Support
0x01	High speed	Support
0x02	HS200	Support
0x03	HS400	Support

[Table 3] HS\_Timing values

#### 4.1.1.1 Bus timing specification in HS400 mode

##### ■ HS400 Device input timing

The CMD input timing for HS400 mode is the same as CMD input timing for HS200 mode.

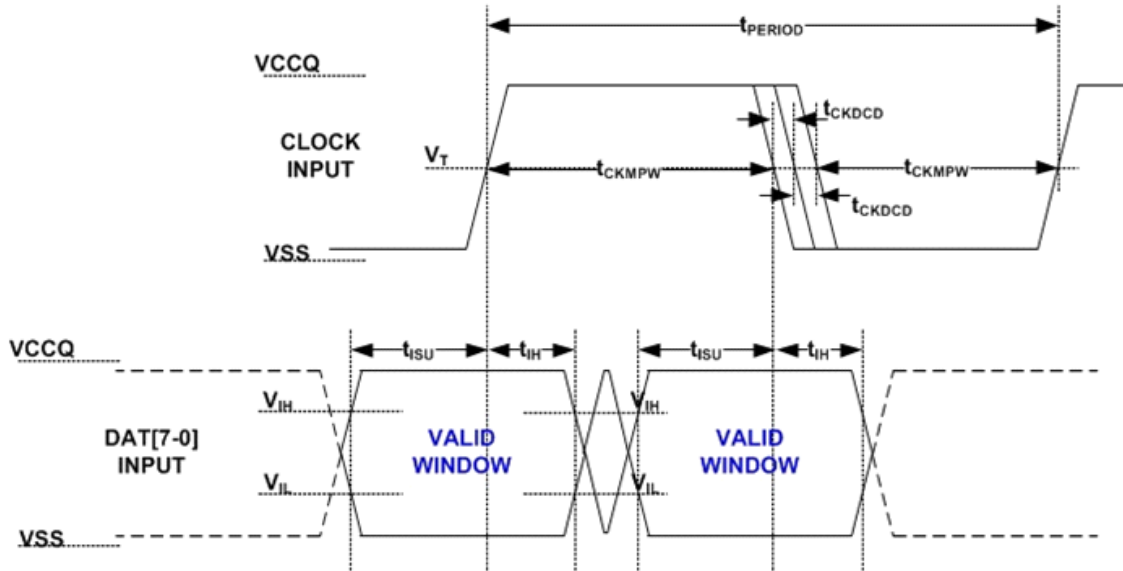

[Figure 4] HS400 Device input timing

Parameter	Symbol	Min	Max	Unit	Remark
Data Strobe					
Cycle time data transfer mode	$t_{PERIOD}$	5			200MHz(Max), between rising edges with respect to $V_T$
Slew rate	SR	1.125		V/ns	With respect to $V_{IH}/V_{IL}$
Duty cycle distortion	$t_{CKDCD}$	0.0	0.3	ns	Allowable deviation from an ideal 50% duty cycle. With respect to $V_T$ . Includes jitter, phase noise
Minimum pulse width	$t_{CKMPW}$	2.2		ns	With respect to $V_T$
Input DAT (referenced to CLK)					
Input set-up time	$t_{ISUddr}$	0.4		ns	$C_{DEVICE} \leq 6pF$ With respect to $V_{IH}/V_{IL}$
Input hold time	$t_{IHddr}$	0.4		ns	$C_{DEVICE} \leq 6pF$ With respect to $V_{IH}/V_{IL}$
Slew rate	SR	1.125		V/ns	With respect to $V_{IH}/V_{IL}$

[Table 4] HS400 Device input timing

### ■ HS400 Device output timing

Data strobe is for reading data in HS400 mode. Data strobe is toggled only during data read or CRC status response.

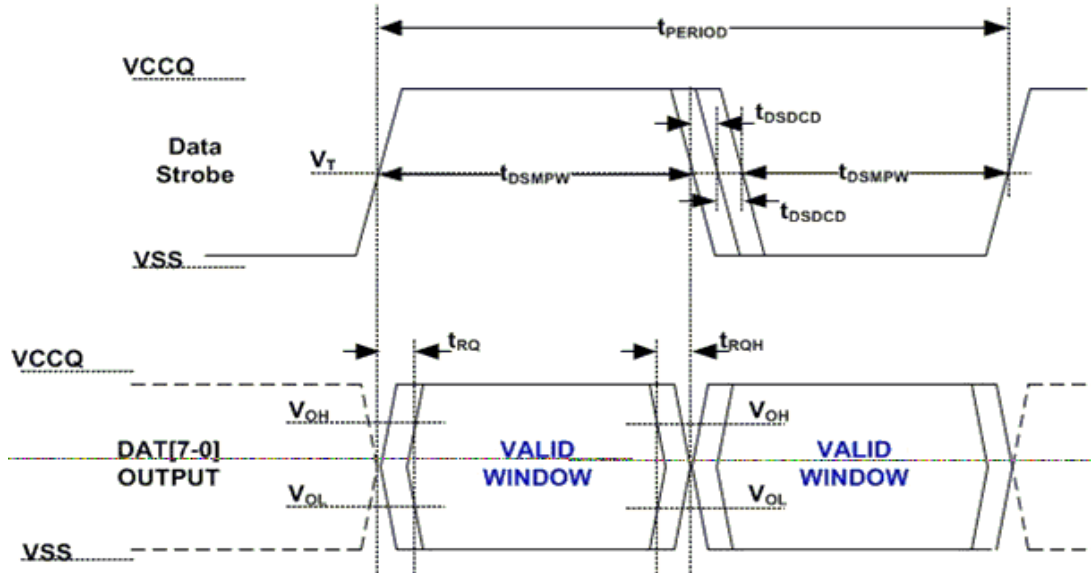

[Figure 5] HS400 Device output timing

Parameter	Symbol	Min	Max	Unit	Remark
Data Strobe					
Cycle time data transfer mode	$t_{PERIOD}$	5			200MHz(Max), between rising edges with respect to $V_T$
Slew rate	SR	1.125		V/ns	With respect to $V_{OH}/V_{OL}$ and HS400 reference load
Duty cycle distortion	$t_{DSDCD}$	0.0	0.2	ns	Allowable deviation from the input CLK duty cycle distortion( $t_{CKDCD}$ ) With respect to $V_T$ Includes jitter, phase noise
Minimum pulse width	$t_{DSMPW}$	2.0		ns	With respect to $V_T$
Read pre-amble	$t_{RPRE}$	0.4	5 (One Clock Cycle)	$t_{PERIOD}$	Max value is specified by manufacturer. value up to infinite is valid.
Read post-amble	$t_{RPST}$	0.4	2.5 (Half Clock Cycle)	$t_{PERIOD}$	Max value is specified by manufacturer. value up to infinite is valid.
Output DAT (referenced to Data strobe)					
Output skew	$t_{RQ}$		0.4	ns	With respect to $V_{OH}/V_{OL}$ and HS400 reference load
Output hold skew	$t_{RQH}$		0.4	ns	With respect to $V_{OH}/V_{OL}$ and HS400 reference load
Slew rate	SR	1.125		V/ns	With respect to $V_{OH}/V_{OL}$ and HS400 reference load

[Table 5] HS400 Device output timing

Parameter	Symbol	Min	Type	Max	Unit	Remark
Pull-up resistance for CMD	$R_{CMD}$	4.7		100	Kohm	
Pull-up resistance for DAT0-7	$R_{DAT}$	10		100	Kohm	
Pull-down resistance for Data strobe	$R_{DS}$	10		100	Kohm	
Internal pull up resistance DAT1-DAT7	$R_{int}$	10		150	Kohm	
Bus signal line capacitance	$C_L$			13	pF	
Single Device capacitance	$C_{Device}$			6	pF	

**[Table 6] HS400 Device input timing\***

\* For connection guide, see Table 20.

### ■ Data Strobe for HS400

Data strobe is Return Clock signal used in HS400 mode. This signal is generated by the device and used for data output and CRC status response output in HS400 mode. The frequency of this signal follows the frequency of CLK. For data output each cycle of this signal directs two bits transfer(2x) on the data - one bit for positive edge and the other bit for negative edge. For CRC status response output, the CRC status is latched on the positive edge only, and don't care on the negative edge. Data strobe signal is toggled only for Data out and CRC response (Align CMD response as well as CRC response to the DS in eMMC5.1)

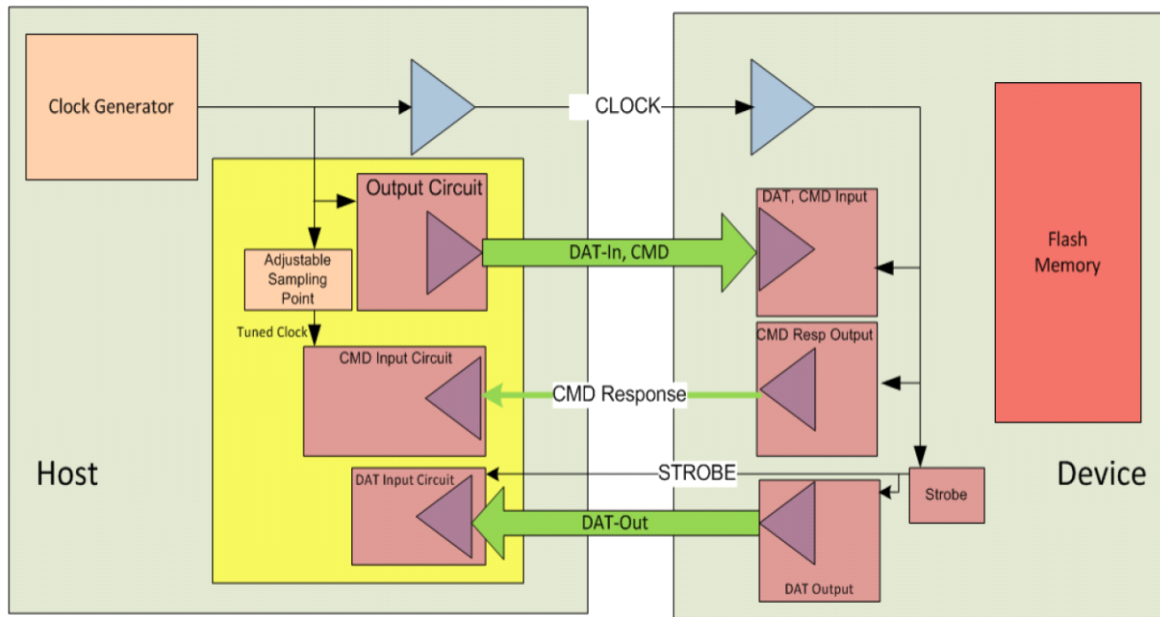

[Figure 6] HS400 Host and Device block diagram



#### 4.1.1.2 HS400 Mode selection

Following JEDEC standard for eMMC5.0, changing bus mode directly from HS200 to HS400 is not allowed. It has a rule for changing bus width from SDR mode to DDR mode that HS\_TIMING must be set to "0x01"(HS mode : 52MHz) before setting BUS\_WIDTH for DDR operation. We recommend the HS400 bus mode selection sequence as following.

**(eMMC5.1 has basically same flow, but 'enhanced strobe feature' is added. Please refer to 4.2.6 Enhanced strobe)**

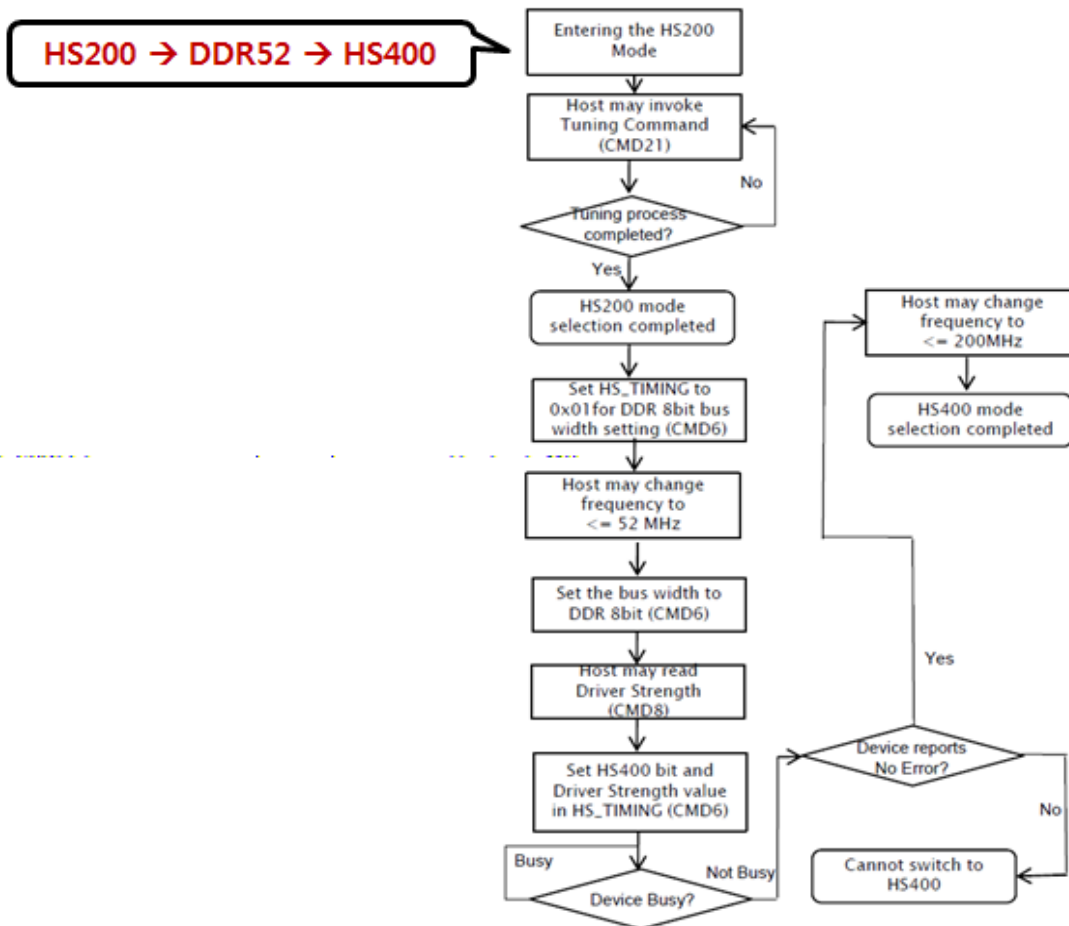

[Figure 7] HS400 Bus mode selection sequence

■ EXT\_CSD register for Data strobe

• Enhanced Strobe field in BUS\_WIDTH [183]

Bit 7	Bit 6	Bit 5	Bit 4	Bit 3	Bit 2	Bit 1	Bit 0
Enhanced Strobe	Reserved			Bus Mode Selection			

BIT[7] : 0: Strobe is provided only during data out and CTC response [Default]  
 1: Strobe is provided during data out, CRC response and CMD response

The support of STROBE\_ENHANCED mode is optional for devices. STROBE\_SUPPORT[184] register of EXT\_CSD indicates whether a device supports that mode.

### 4.1.2 Field firmware update (FFU)

To download a new firmware, the e-NAND requires instruction sequence following JEDEC standard. SK hynix e-NAND only supports Manual mode (MODE\_OPERATION\_CODES is not supported). For more details, see as the following chart and register table given below.

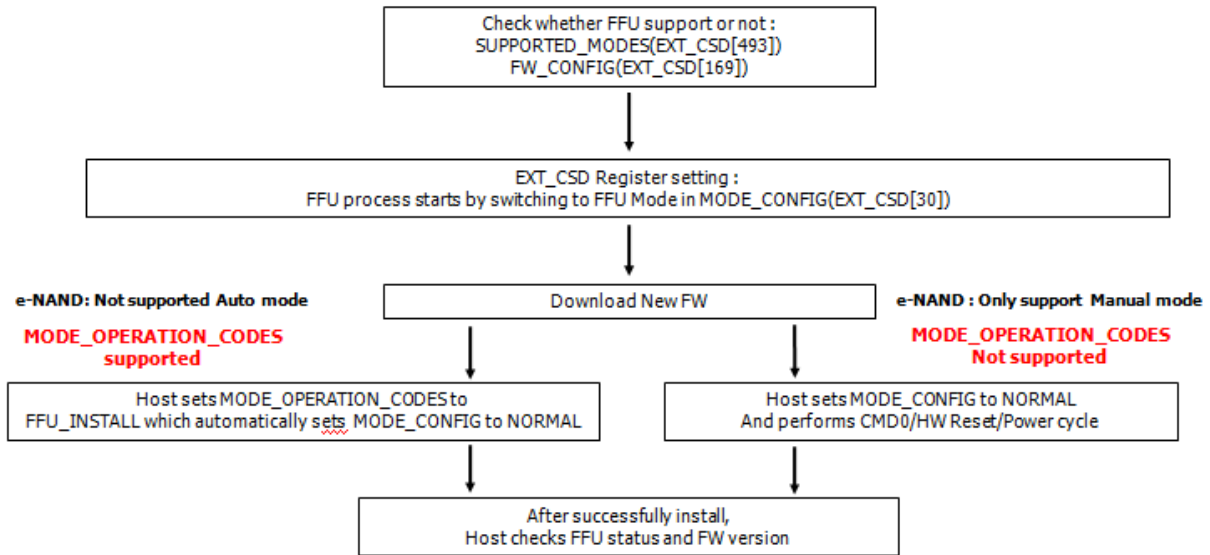

[Figure 8] FFU flow chart

#### 4.1.2.1 Field F/W update flow - CMD sequence

Operation	CMD	Remark
Set bus width (1bit or 4bit)		Bus width should be 1bit or 4bit
Set block length 512B	CMD16, arg : 0x00000200	
Enter FFU mode	CMD6, arg : 0x031E0100	
Send FW to device(Download)	CMD25, arg : 0xFFFAFFF0	Sending CMD25 is followed by sending FW data
CMD12 : Stop	CMD12, arg : 0x00000000	
CMD6 : Exit FFU mode	CMD6, arg : 0x031E0000	
CMD0/HW Reset/Power cycle		
Re-Init to trans state	CMD0, CMD1 ...	
Check if FFU is succeeded	CMD8, arg : 0x00000000	Check EXT_CSD[26] : FFU_SUCCESS If FFU_SUCCESS is 0, FFU is succeeded, otherwise FFU is failed.

#### 4.1.2.2 EXT\_CSD Register for FFU

##### ■ SUPPORTED\_MODE[493] (Read Only)

BIT[0] : '0' FFU is not supported by the device. '1' FFU is supported by the device.

BIT[1] : '0' Vendor specific mode (VSM) is not supported by the device. '1' Vendor specific mode is supported by the device.

Bit	Field	Supportability
Bit[7:2]	Reserved	
Bit[1]	VSM	Not support
Bit[0]	FFU	Supported

##### ■ FFU\_FEATURE[492] (Read Only)

BIT[0] : '0' Device does not support MODE\_OPERATION\_CODES field (Manual mode)

'1' Device supports MODE\_OPERATION\_CODES field (Auto mode)

Bit	Field	Supportability
Bit[7:1]	Reserved	
Bit[0]	SUPPORTED_MODE_OPERATION_CODES	Not support

##### ■ FF\_ARG[490-487] (Read Only)

Using this field the device reports to the host which value the host should set as an argument for read and write commands is FFU mode.

##### ■ FF\_CONFIG[169] (R/W)

BIT[0] : Update disable

0x0 : FW updates enabled. / 0x01 : FW update disabled permanently

Bit	Field	Supportability
Bit[7:1]	Reserved	
Bit[0]	Update disable	FW updates enabled (0x0)

### ■ FFU\_STATUS[26] (R/W/E\_P)

Using this field the device reports to the host the state of FFU process.

Value	Description
0x13 ~ 0xFF	Reserved
0x12	Error in downloading Firmware
0x11	Firmware install error
0x10	General error
0x01 ~ 0x0F	Reserved
0x00	Success

### ■ OPERATION\_CODES\_TIMEOUT[491](Read Only)

Maximum timeout for the SWITCH command when setting a value to the MODE\_OPERATION\_CODES field

The register is set to '0', because the e-NAND doesn't support MODE\_OPERATION\_CODES.

Value	Description	Timeout value
0x01 ~ 0x17	$\text{MODE\_OPERATION\_CODES\_TIMEOUT} = 100\mu\text{s} \times 2^{\text{MODE\_OPERATION\_CODES\_TIMEOUT}}$	0 (Not defined)
0x18 ~ 0xFF	Reserved	

### ■ MODE\_OPERATION\_CODES[29] (W/E\_P)

The host sets the operation to be performed at the selected modes, in case MODE\_CONFIGS is set to FFU\_MODE,

MODE\_OPERATION\_CODES could have the following values :

Bit	Description
0x01	FFU_INSTALL
0x02	FFU_ABOUT
0x00, others	Reserved

### 4.1.3 Health Report

Using this feature is for monitoring device status and preventing the error and failure in advance. Host can check device information with EXT\_CSD as the register table given below.

Field	CSD slice	Description
VENDOR_PROPRIETARY_HEALTH_REPORT	[301:270]	Reserved for vendor proprietary health report. (NONE)
DEVICE_LIFE_TIME_EST_TYPE_A/B	[269:268]	Current average P/E cycle of memory of Type A(SLC) / Type B(MLC) relative to its maximum estimated capability
PRE_EOL_INFO	[267]	Consumed reserved blocks to notify before reaching the EOL (End of life) status
OPTIMAL_TRIM/WRITE_READ_SIZE	[266:264]	Minimum optimal (for the device) Erase / Write / Read unit size for the different partitions
DEVICE_VERSION	[263:262]	Device version
FIRMWARE_VERSION	[261:254]	Device FW version

**[Table 7] Using EXT\_CSD for health report (Read only)**

#### 4.1.4 Sleep Notification

Host may use to a power off notification when it intends to turn-off  $V_{CC}$  After moving the device to sleep state. Some features are added to clarify the spec for entering sleep mode when power off notification is enabled.

##### ■ Add the SLEEP\_NOTIFICATION on the interruptible Command List

CMD	Description	Is interruptible?
CMD6	SWITCH, Byte POWER_OFF_NOTIFICATION, Value POWER_OFF_LONG or SLEEP_NOTIFICATION	Yes

##### ■ SLEEP\_NOTIFICATION\_TIME[216](Read Only)

Maximum timeout for the SWITCH command when notifying the device that it is about to move to sleep state by writing SLEEP\_NOTIFICATION to POWER\_OFF\_NOTIFICATION[34]byte. (unit : 10us)

Value	Description	Timeout value
0x01 ~ 0x17	Sleep Notification Timeout = $10\mu s \times 2^{SLEEP\_NOTIFICATION\_TIME}$	0x0E(163.84ms)
0x18 ~ 0xFF	Reserved	

##### ■ POWER\_OFF\_NOTIFICATION[34]

Add 0x04h for the SLEEP\_NOTIFICATION as a valid value

Value	Field	Description
:	:	:
0x03	POWER_OFF_LONG	Host is going to power off the device. The device shall respond within POWER_OFF_LONG_TIME
0x04	SLEEP_NOTIFICATION	Host is going to put device in sleep mode. The device shall respond within SLEEP_NOTIFICATION_TIME

#### 4.1.5 Secure Removal type

This feature is used for how information is removed from the physical memory during a purge operation.

##### ■ Secure Removal Type[16]

Among four options for secure removal type, e-NAND supports 0x3, 0x1 and 0x0 (0x2 option is not supported) e-NAND recommends using a vendor defined removal type(type 3). If host want to erase the device physically using removal type0. Secure erase & Secure trim time is longer than using removal type3

BIT	Description of Secure Removal Type	Description		Supportability
BIT[5:4]	Configure Secure Removal Type (R/W)	0x3	Information removed using a vendor defined	-
		0x2	Information removed by an overwriting the addressed locations with a character, its complement, then a random character	-
		0x1	Information removed by an overwriting the addressed locations with a character followed by an erase	-
		0x0	Information removed by an erase of the physical memory	-
BIT[3:0]	Supported Secure Removal Type (R)	BIT[3]	Information removed using a vendor defined	Supported
		BIT[2]	Information removed by an overwriting the addressed locations with a character, its complement, then a random character	Not supported
		BIT[1]	Information removed by an overwriting the addressed locations with a character followed by an erase	Supported (but, same operating to type 0)
		BIT[0]	Information removed by an erase of the physical memory	Supported



## 4.2 eMMC5.1 New features

### 4.2.1 Command queuing

e-NAND manages an internal task queue to which the host can queue data transfer tasks to efficient operate.

#### 4.2.1.1 CMD list for Command queuing

Index	Abbreviation	Argument	Remark
<b>CMD44</b>	Queued_Task_parameter	[31] Reliable Write Request [30] Data Direction (Read=1, Write=0) [29] Tag Request [28:25] context ID [24] Forced Programming [23] Priority ( simple =0, high=1) [20:16] Task ID(31~0) [15:0] # of BLK	Encodes parameter which are necessary for queuing the task and executing the transfer
<b>CMD45</b>	Queued_Task_Address	[31:0] Block address for the transaction	The host instructs the device to queue a data transfer task
<b>CMD46</b>	Execute_Read_Task	[20:16] Task ID of the requested task which is must marked as "ready for execution" in the Queue Status Register	In order to execute a data read task (CMD46) or write task(CMD47) which is already queued
<b>CMD47</b>	Execute_Write_Task		
<b>CMD48</b>	CMDQ_TASK_MGMT	[31:21] reserved [20:16]: TaskID [15:4]: reserved [3:0] TM op-code	Device shall discard a specific task or entire queue (all tasks in the queue) [20:16] when TM op-code = 2h these bits represent TaskID. When TM op-code=1h these bits are reserved.

Index	Abbreviation	Argument	Remark
<b>CMD13</b>	SEND_STATUS	[31:16] RCA [15] <b>SQS</b> [14] Stuff bits [0] HPI	In case SQS bit = 1: indicate that this is CMD13 of CMD Queue. In response device shall send the QSR. In this case HPI bit muse be set to '0'.

#### 4.2.1.2 EXT\_CSD Register for Command queuing

##### ■ CMDQ\_SUPPORT[308](Read only)

This field indicates whether command queuing is supported by the device.

BIT[0]: 0: Command queuing is not supported

1: Command queuing is supported

Bit	Field	Supportability
Bit[7:1]	Reserved	-
Bit[0]	CMDQ Support	Supported (0x1)

##### ■ CMDQ\_DEPTH[307](Read only)

This field is used to calculate the depth of the queue supported by the device. The maximum depth allowed by the standard is 32. The range of allowed Task IDs is 0 through N.

BIT[4:0]: N, a parameter used to calculate the Queue Depth of task queue in the device.

Queue Depth = N+1.

Bit	Field	CMD queue depth value
Bit[7:5]	Reserved	-
Bit[4:0]	N	N=31 (0x1F)

##### ■ CMDQ\_MODE\_EN[15](R/W)

This field is used by the host enable command queuing mechanism if supported by the device.

BIT[0]: 0: Command queuing is disabled. Host should clear the queue empty using CMD48 prior disabling the queue.

1: Command queuing is enabled

Bit	Field	Supportability
Bit[7:1]	Reserved	-
Bit[0]	CMDQ enable	-

To maintain backward compatibility with hosts, which do not support command queuing, when the command queuing is disabled other functionality of the device is as if the device does not support command queuing.

#### 4.2.1.3 New register for Command queuing

##### ■ QSR (Queue Status Register)

The 32bit QSR carries the state of tasks in the queue at a specific point in time.

The host has read access to this register through device response to SEND\_STATUS command(CMD13 with bit[15]="1"), R1's argument will be the QSR.

Every bit in the QSR represents the task who's ID corresponds to the bit index.

If bit  $QSR[i]=0$ , the queued task with a Task ID  $i$  is not ready for execution.

The task may be queued and pending, or the Task ID is unused.

If bit  $QSR[i]=1$ , the queued task with Task ID  $i$  is ready for execution.

#### 4.2.1.4 Command queuing Flows

**For enter the CMD Queuing Mode,**  
 CMD\_Q\_EN(bit[0] of EXT\_CSD[15]) is set to '1'

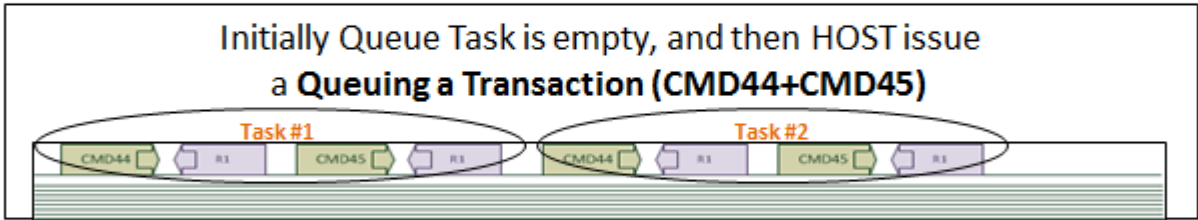

**Checking the Queue Status (SEND\_STATUS : CMD13)**  
 HOST set the SQS bit = 1, for read the QSR.  
 The device responds with an R1 with the QSR in its argument.

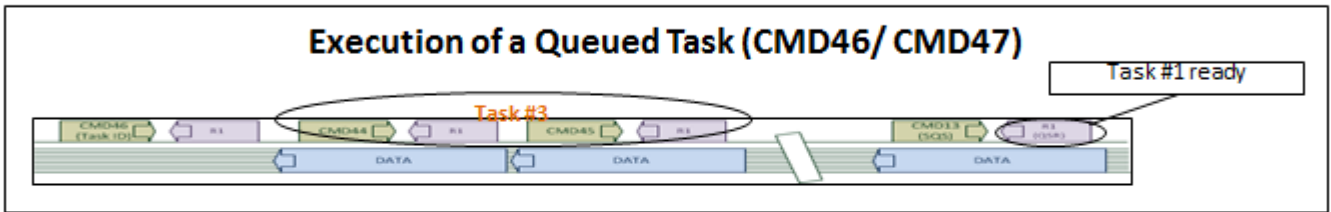

**For end the CMD Queuing Mode,**  
 HOST should clear the Queue Task to be empty, using CMD48 before disabling the Queue.

## 4.2.2 Cache Barrier

There are cases where the host is not interested in flushing the data right away, however it would like to keep an order between different cached data.

The flushing can be delayed by the device to some later idle time. Barrier commands avoid the long delay by flush commands.

- Arrival sequence



- Flush sequence

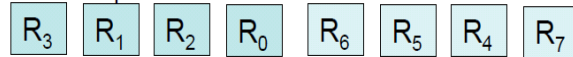

### 4.2.2.1 EXT\_CSD Register for Cache Barrier

#### ■ BARRIER\_SUPPORT[488](Read only)

This field indicates whether the device supports the barrier command.

BIT[7:0]: 0: Barrier command is not supported

1: Barrier command is supported

Bit	Field	Supportability
Bit[7:0]	BARRIER_SUPPORT	Supported (0x1)

#### ■ FLUSH\_CACHE[32](W/E\_P)

A barrier command is issued by setting BARRIER bit. All data cached before the barrier shall be flushed to the non-volatile memory before any request after the barrier command.

Data in the cache shall be flushed to the non-volatile storage by setting the FLUSH bit.

BIT[1]: 0: Reset value

1: Set barrier

BIT[0]: 0: Reset value

1: Triggers the flush

Bit	Field	Supportability
Bit[7:2]	Reserved	-
Bit[1]	BARRIER	-
Bit[0]	FLUSH	-

### ■ BARRIER\_CTRL[31](R/W)

This field is used by the host enable barrier command mechanism if supported by the device.

BIT[0]: 0: Barrier feature is OFF

1: Barrier feature is ON

Bit	Field	Supportability
Bit[7:1]	Reserved	-
Bit[0]	BARRIER_EN	-

#### 4.2.2.2 Cache barrier Flows

##### 1. Support Barrier command

- The device exposes its barrier support capability via the BARRIER\_SUPPORT (EXT\_CSD byte [486])

##### 2. Enable Barrier command

- The host shall set bit 0 of BARRIER\_EN (EXT\_CSD byte [31])

##### 3. Cache on

##### 4. Send data

##### 5. Set Barrier

- The host shall set both BARRIER bit and FLUSH bit of the FLUSH\_CACHE (EXT\_CSD byte [32])

### 4.2.3 Cache Flushing Report

For devices which flush cached data in an in-order manner, cache barrier commands are redundant and impose a needless overhead to the device and host.

#### 4.2.3.1 EXT\_CSD Register for Cache Flushing Report

##### ■ CACHE\_FLUSH\_POLICY[240](Read only)

BIT[0]: 0: Device flushing policy is not provided by the device.

1: Device is using a FIFO policy for cache flushing

Bit	Field	Supportability
Bit[7:1]	Reserved	-
Bit[0]	FIFO	Supported (0x01)

### 4.2.4 BKOP Control

This feature allows the host to indicate to the device if it is expected to periodically manually start background operations by writing to the BKOPS\_START field.

#### 4.2.4.1 EXT\_CSD Register for BKOP Control

##### ■ BKOP\_EN[163](R/W/E, R/W)

BIT[1](R/W/E): 0: Device shall not perform background operations while not servicing the host.

1: Device may perform background operations while not servicing the host.

BIT[0] (R/W): 0: Host does not support background operations handling and is not expected to write to BKOPS\_START field.

1: Host is indicating that it shall periodically write to BKOPS\_START field to manually start background operations.

Bit	Field	Supportability
Bit[7:2]	Reserved	-
Bit[1]	AUTO_EN	-
Bit[0]	MANUAL_EN	-

#### 4.2.5 Secure Write Protection

Any application running on the host may issue write protection by updating fields of write protection related EXT\_CSD, like USER\_WP[171], BOOT\_WP[173], by issuing CMD6, CMD8, CMD28 and CMD29 (Legacy mode). However there are weak points in the legacy mode. To prevent un-authorized changes, host should enter the secure write protect mode

- In Secure WP Mode, WP related EXT\_CSDs (EXT\_CSD[171],[173]) can be updated only if SECURE\_WP\_MASK fields is 0x1.
- Secureness is provided by allowing only RPMB method to update the register for SECURE\_WP\_MASK.
- Automatic Write protection mode is added to prevent security hole by power-control security attack.

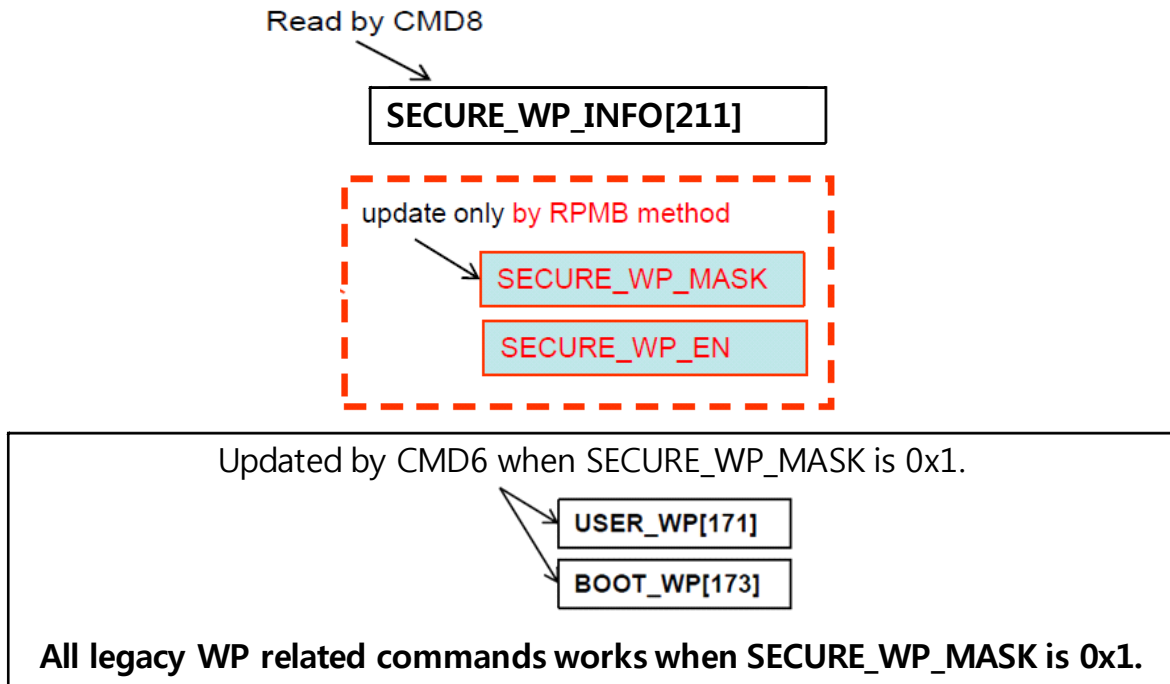



#### 4.2.5.1 EXT\_CSD Register for Secure Write Protection

##### ■ SECURE\_WP\_INFO[211](Read Only)

The SECURE\_WP\_SUPPORT field indicates whether the device is supporting secure write protection mode.

The SECURE\_WP\_EN\_STATUS is showing the value of SECURE\_WP\_EN defined in Authenticated Device Configuration Area.

BIT[1] 0: Legacy Write Protection mode  
1: Secure Write Protection mode

BIT[0] 0: Secure Write Protection is NOT supported by this device  
1: Secure Write Protection is supported by this device

Bit	Field	Supportability
Bit[7:2]	Reserved	-
Bit[1]	SECURE_WP_EN_STATUS	-
Bit[0]	SECURE_WP_SUPPROT	Supported (0x01)

#### 4.2.5.2 New register for Secure Write Protection

##### ■ Authenticated Device Configuration Area

- Hidden register instead of EXT\_CSD register for SECURE\_WP\_MODE\_CONFIG, ENABLE.
- Those two SECURE\_WP\_MODE\_CONFIG and SECURE\_WP\_MODE\_ENABLE registers are defined in Device Configuration area, and those register should be updated only by Authenticated Device Configuration write request. (RPMB)

Name	Field	Size (Bytes)	Cell Type	Address
Reserved	Reserved	253	-	[255:3]
Secure Write Protect Configuration	SECURE_WP_MODE_CONFIG	1	R/W/E_P	[2]
Secure Write Protect Enable	SECURE_WP_MODE_ENABLE	1	R/W/E	[1]
Reserved		1		[0]

### ■ Authenticated Device Configuration Area (1) : SECURE\_WP\_MODE\_ENABLE (R/W/E)

The byte is to enter/exit the secure write protection mode.

If host want a device to enter the secure Write Protection mode, host set the SECURE\_WP\_EN bit as '0x1' in this register using Authenticated Device Configuration Write request. This register can be read using Authenticated Device Configuration Read request. If there are already write protected groups or write protected boot partitions, those will be preserved when entering or exiting secure Write protected mode.

Bit [0] 0: Legacy Write Protection mode.

(TMP\_WRITE\_PROTECT[12], PERM\_WRITE\_PROTECT[13] is updated by CMD27. USER\_WP[171], BOOT\_WP[173] and BOOT\_WP\_STATUS[174] are updated by CMD6.)

1: Secure Write Protection mode.

(The access to the write protection related EXT\_CSD and CSD fields depends on the value of SECURE\_WP\_MASK bit in SECURE\_WP\_MODE\_CONFIG field.)

The default value of this field is 0x0.

Bit	Field	Supportability
Bit[7:1]	Reserved	-
Bit[0]	SECURE_WP_MODE_ENABLE	-

## ■ Authenticated Device Configuration Area (2) : SECURE\_WP\_MODE\_CONFIG (R/W/E\_P)

In secure write protected mode, the updatability of USER\_WP[171], BOOT\_WP[173], TMP\_WRITE\_PROTECT[12] and PERM\_WRITE\_PROTECT[13] are controlled by this mask value.

Bit [0] 0: Disabling updating WP related EXT\_CSD and CSD fields. CMD27 (Program CSD) will generate generic error for setting TMP\_WRITE\_PROTECT[12] , PERM\_WRITE\_PROTECT[13]. CMD6 for updating USER\_WP[171], BOOT\_WP[173] and BOOT\_WP\_STATUS[174] generates SWITCH\_ERROR. If a force erase command is issued, the command will fail (Device stays locked) and the LOCK\_UNLOCK\_FAILED error bit will be set in the status register. If CMD28 or CMD29 is issued, then generic error will be occurred. Power-on Write Protected boot partitions will keep protected mode after power failure, H/W reset assertion and any CMD0 reset. The device keeps the current value of BOOT\_WP in the EXT\_CSD register to be same after power cycle, H/W reset assertion, and any CMD0 reset.

1: Enabling updating WP related EXT\_CSD and CSD fields.

(TMP\_WRITE\_PROTECT[12] , PERM\_WRITE\_PROTECT[13] , USER\_WP[171], BOOT\_WP[173] and BOOT\_WP\_STATUS[174] are accessed using CMD6, CMD8 and CMD27. If a force erase command is issued and accepted, then ALL THE DEVICE CONTENT WILL BE ERASED including the PWD and PWD\_LEN register content and the locked Device will get unlocked. If a force erase command is issued and power-on protected or a permanently-write-protected write protect groups exist on the device, the command will fail (Device stays locked) and the LOCK\_UNLOCK\_FAILED error bit will be set in the status register. An attempt to force erase on an unlocked Device will fail and LOCK\_UNLOCK\_FAILED error bit will be set in the status register. Write Protection is applied to the WPG indicated by CMD28 with the WP type indicated by the bit[2] and bit[0] of USER\_WP[171]. All temporary WP Groups and power-on Write Protected boot partitions become writable/erasable temporarily which means write protect type is not changed. All power-on and permanent WP Groups in user area will not become writable/erasable temporarily. Those temporarily writable/erasable area will become write protected when this bit is cleared to 0x0 by the host or when there is power failure, H/W reset assertion and any CMD0 reset. The device keeps the current value of BOOT\_WP CSD register to be same after power cycle, H/W reset assertion, and any CMD0 reset.)

The default value of this field is 0x0.

Bit	Field	Supportability
Bit[7:1]	Reserved	-
Bit[0]	SECURE_WP_MODE_CONFIG	-

#### 4.2.5.3 RPMB Types for accessing Authenticated Device Configuration Area

Secure WP Enable & Configuration registers are defined in Authenticated Device Configuration Area which only can be accessible by new RPMB operations.

<b>Request Message Types</b>	
0x0001	Authentication key programming request
0x0002	Reading of the Write Counter value –request
0x0003	Authenticated data write request
0x0004	Authenticated data read request
0x0005	Result read request
0x0006	Authenticated Device Configuration Write request
0x0007	Authenticated Device Configuration Read request
<b>Response Message Types</b>	
0x0100	Authentication key programming response
0x0200	Reading of the Write Counter value –response
0x0300	Authenticated data write response
0x0400	Authenticated data read response
0x0600	Authenticated Device Configuration Write response
0x0700	Authenticated Device Configuration Read response

#### 4.2.6 Enhanced strobe

In Enhanced Strobe mode DATA OUT, CRC Response and CMD Response are all synced to STROBE clocks. The timing relation between CMD Response output signals and STROBE clocks is the same as defined for DATA Out to STROBE clocks.

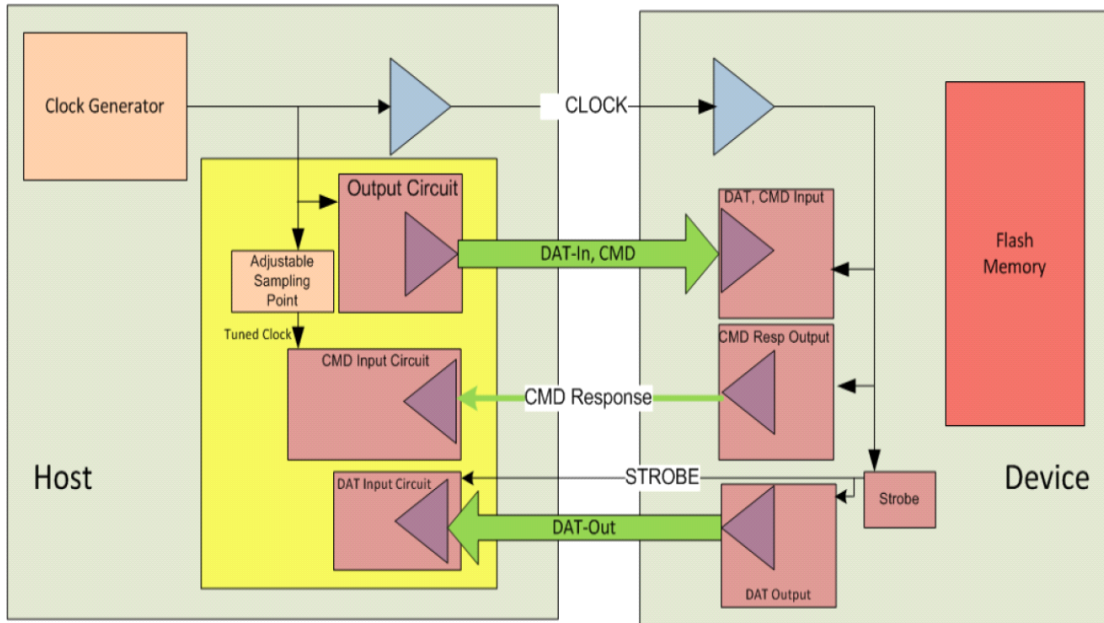

[Figure 9] HS400 Host and Device block diagram (when Enhanced Strobe is enabled)

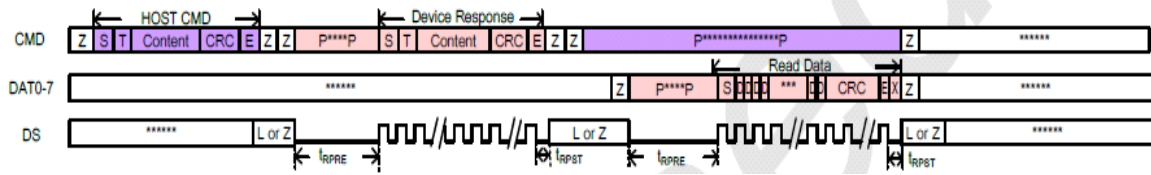

[Figure 10] Enhanced Strobe signals for CMD Response and Data Out (Read operation)

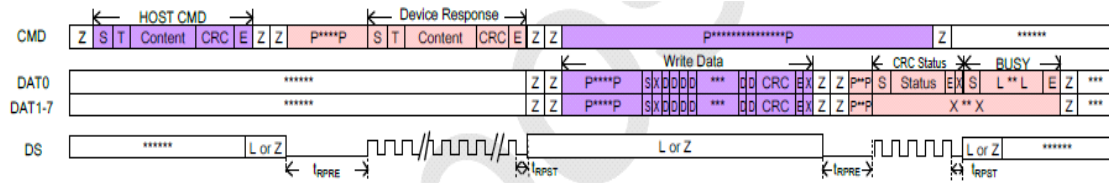

[Figure 11] Enhanced Strobe signals for CMD Response and Data Out (Write operation)

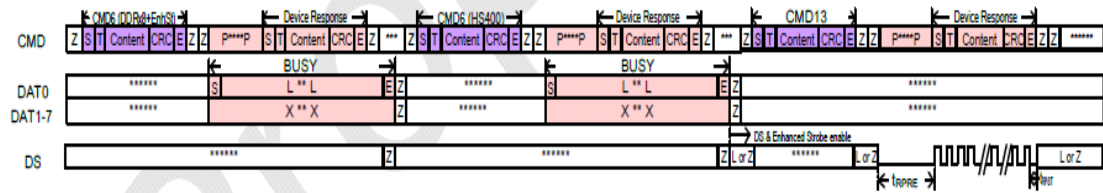

[Figure 12] HS400 mode change with Enhanced Strobe

#### 4.2.6.1 EXT\_CSD Register for Enhanced Strobe

##### ■ STROBE\_SUPPORT[184](Read only)

This register indicates whether a device supports Enhanced Strobe mode for operation modes that STROBE is used for HS400.

BIT[7:0]: 0: Indicates No support of Enhanced Strobe mode

1: Indicates the device supports Enhanced Strobe mode

Bit	Field	Supportability
Bit[7:0]	<b>STROBE_SUPPORT</b>	Supported (0x01)

#### 4.2.6.2 HS400 mode (Enhanced Strobe) selection

This selection flow describes how to initialize the eMMC device in HS400 mode while enabling Enhanced Strobe without the need for tuning procedure.

After the host initializes the device, host check whether the device supports the HS400 mode and Enhanced Strobe by reading the DEVICE\_TYPE and STROBE\_SUPPORT fields in the Extended CSD register.

After power-on or software reset (CMD0), the interface timing of the device is set as the default 'Backward Compatible Timing'. In order to switch to HS400 mode with Enhanced Strobe, host should perform the following steps.

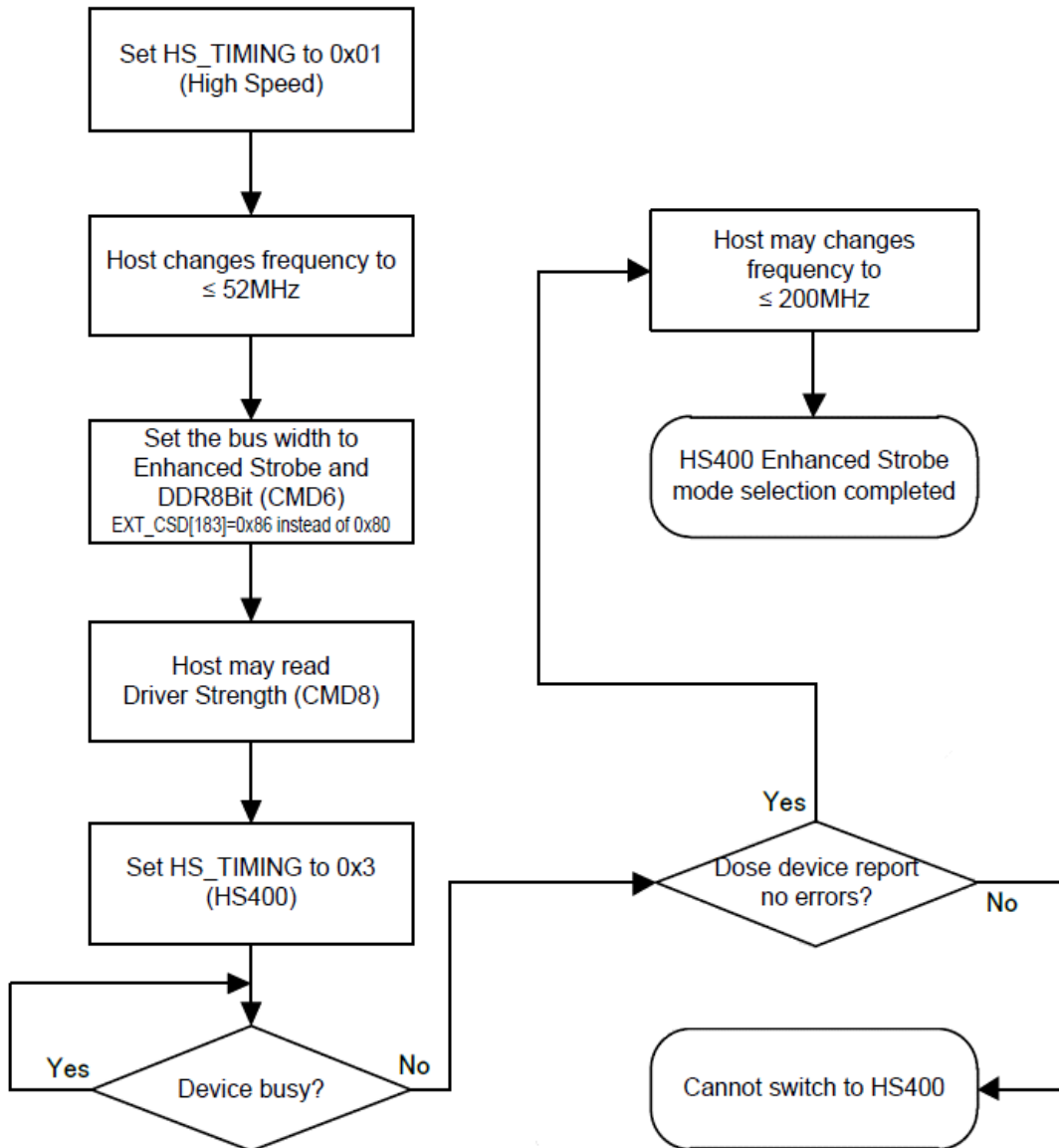

[Figure 13] HS400 Bus mode (Enhanced Strobe) selection flow diagram



#### 4.2.7 RPMB throughput improvement

This feature is proposed for RPMB write data size to improve the RPMB throughput in eMMC5.1 spec.

In the eMMC5.0 spec, REL\_WR\_SEC\_C[222] register shall be set to 1 (hence the granularity is always 512B.)

- For reliable write to RPMB partition, there is limitation that block count can not exceed the size of REL\_WR\_SEC\_C x 512B.

In eMMC5.1, the supported RPMB write access size is 256B, 512B, and 8KB.

#### ■ WRITE\_REL\_PARAM (EXT\_CSD[166]): Read only

##### When EXT\_CSD[166][4] (R) = 0

- Device does not support large RPMB write transfer
- The behavior is same as eMMC v5.0 or earlier

##### When EXT\_CSD[166][4] (R) = 1

- Device supports large RPMB write transfer
- Host transfers small RPMB write with block count = 1 or 2 (256/512B)
- Host transfers large RPMB write with block count = 32 (8KB)
- \* the start address should be 8KB aligned, and the transferred data (8KB) is all-new or all-old

Bit	Field	Supportability
Bit[4]	EN_RPMB_REL_WR	Supported (0x01)

### 4.3 Enhanced features from eMMC4.5 to eMMC5.1

Several e-NAND features are changed from eMMC4.5 to eMMC5.1 enhance the e-NAND performance.

Parameter	eMMC4.5	eMMC5.0	eMMC5.1	Description
HPI Features	CMD12	CMD13	CMD13	Following industry wise common configuration.
Max. Packed CMD count	8ea	63ea	63ea	Expanded the packed CMD size for optimized device performance.
Max. CMD Queue depth	Not Support	Not Support	32ea	CMD queue is added in eMMC5.1
Cache size	<	<	<	Cache size is increasing for optimized device performance with 4-way interleave implementation.
I/O Driver Strength	Support Type0	Support all type	Support all type	e-NAND supports all of driver strength types for eMMC5.0

**[Table 8] Enhanced features from eMMC4.5 to eMMC5.1**

## 5. e-NAND general parameters

### 5.1 Timing

#### 5.1.1 Bus timing

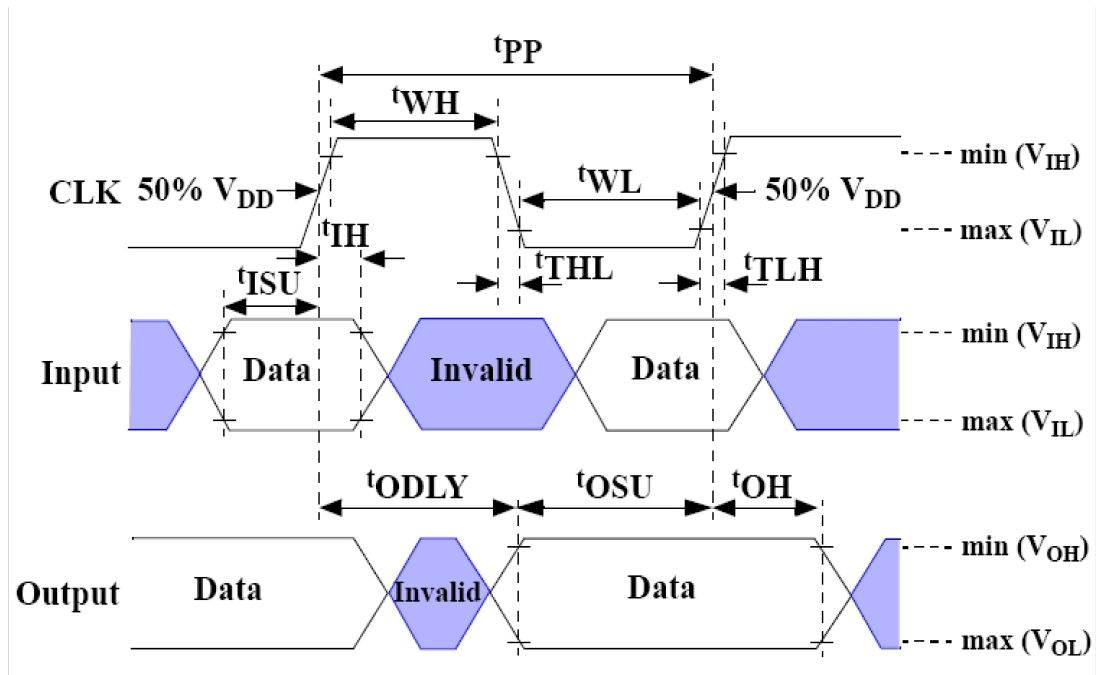

**Data must always be sampled on the rising edge of the clock.**

[Figure 14] Timing diagram: data input/output

Parameter	Symbol	Min	Max	Unit	Remark
<b>Clock CLK</b>					
Clock frequency data transfer mode (PP)	$f_{PP}$	0	52	MHz	$C_L \leq 30$ pF Tolerance: +100KHz
Clock frequency identification mode (OD)	$f_{OD}$	0	400	KHz	Tolerance: +20KHz
Clock high time	$t_{WH}$	6.5		ns	$C_L \leq 30$ pF
Clock low time	$t_{WL}$	6.5		ns	$C_L \leq 30$ pF
Clock rise time	$t_{TLH}$		3	ns	$C_L \leq 30$ pF
Clock fall time	$t_{THL}$		3	ns	$C_L \leq 30$ pF
<b>Inputs CMD, DAT (referenced to CLK)</b>					
Input set-up time	$t_{ISU}$	3		ns	$C_L \leq 30$ pF
Input hold time	$t_{IH}$	3		ns	$C_L \leq 30$ pF
<b>Outputs CMD, DAT (referenced to CLK)</b>					
Output delay time during data transfer	$t_{ODLY}$		13.7	ns	$C_L \leq 30$ pF
Output hold time	$t_{OH}$	2.5		ns	$C_L \leq 30$ pF
Signal rise time	$t_{RISE}$		3	ns	$C_L \leq 30$ pF
Signal fall time	$t_{FALL}$		3	ns	$C_L \leq 30$ pF

**[Table 9] High-speed e-NAND interface timing**

- CLK timing is measured at 50% of VDD.
- e-NAND shall support the full frequency range from 0-26Mhz, or 0-52MHz
- CLK rising and falling times are measured by min ( $V_{IH}$ ) and max ( $V_{IL}$ ).
- Input CMD, DAT rising and falling times are measured by min ( $V_{IH}$ ) and max ( $V_{IL}$ ), and output CMD, DAT rising and falling times are measured by min ( $V_{OH}$ ) and max ( $V_{OL}$ ).

Parameter	Symbol	Min	Max	Unit	Remark
<b>Clock CLK</b>					
Clock frequency data transfer mode (PP)	$f_{PP}$	0	26	MHz	$C_L \leq 30$ pF
Clock frequency identification mode (OD)	$f_{OD}$	0	400	KHz	
Clock high time	$t_{WH}$	10		ns	$C_L \leq 30$ pF
Clock low time	$t_{WL}$	10		ns	$C_L \leq 30$ pF
Clock rise time	$t_{TLH}$		10	ns	$C_L \leq 30$ pF
Clock fall time	$t_{THL}$		10	ns	$C_L \leq 30$ pF
<b>Inputs CMD, DAT (referenced to CLK)</b>					
Input set-up time	$t_{ISU}$	3		ns	$C_L \leq 30$ pF
Input hold time	$t_{IH}$	3		ns	$C_L \leq 30$ pF
<b>Outputs CMD, DAT (referenced to CLK)</b>					
Output set-up time	$t_{OSU}$	11.7		ns	$C_L \leq 30$ pF
Output hold time	$t_{OH}$	8.3		ns	$C_L \leq 30$ pF

**[Table 10] Backward-compatible e-NAND interface timing**

- e-NAND must always start with the backward-compatible interface timing. The timing mode can be switched to high-speed timing by the host sending the switch command (CMD6) with the argument for high speed interface select.
- CLK timing is measured at 50% of VDD.
- CLK rising and falling times are measured by min ( $V_{IH}$ ) and max ( $V_{IL}$ ).
- $t_{OSU}$  and  $t_{OH}$  are defined as values from clock rising edge. However, there may be cards or devices which utilize clock falling edge to output data in backward compatibility mode.  
Therefore, it is recommended for hosts either to set  $t_{WL}$  value as long as possible within the range which should not go over  $t_{CK}-t_{OH}(\text{min})$  in the system or to use slow clock frequency, so that host could have data set up margin for those devices.  
In this case, each device which utilizes clock falling edge might show the correlation either between  $t_{WL}$  and  $t_{OSU}$  or between  $t_{CK}$  and  $t_{OSU}$  for the device.

### 5.1.2 Bus timing for DAT Signals During 2x Data Rate Operation

These timings apply to the DAT[7:0] signals only when the device is configured for dual data mode operation. In dual data mode, the DAT signals operate synchronously of both the rising and the falling edges of CLK.

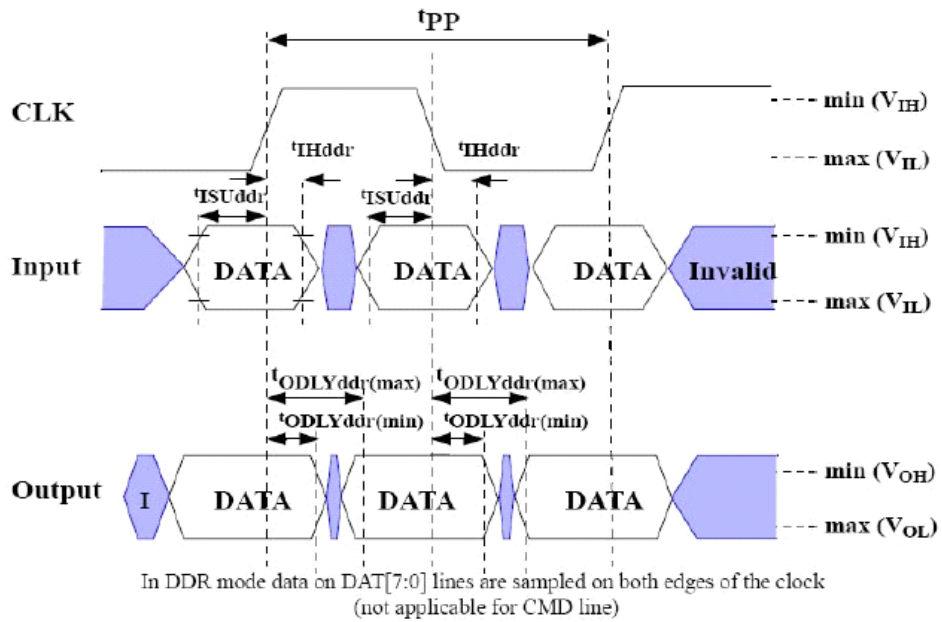

**[Figure 15] Timing diagram: data input/output in dual data rate mode**

Parameter	Symbol	Min.	Max.	Unit	Remark
<b>Input CLK<sup>(1)</sup></b>					
Clock duty cycle		45	55	%	Includes jitter, phase noise
Clock rise time	$t_{TLH}$		3	ns	$CL \leq 30$ pF
Clock fall time	$t_{THL}$		3	ns	$CL \leq 30$ pF
<b>Input CMD (referenced to CLK-SDR mode)</b>					
Input set-up time	$t_{ISUddr}$	3		ns	$CL \leq 20$ pF
Input hold time	$t_{IHddr}$	3		ns	$CL \leq 20$ pF
<b>Output CMD (referenced to CLK-SDR mode)</b>					
Output delay time during data transfer	$t_{ODLY}$		13.7	ns	$CL \leq 20$ pF
Output hold time	$t_{OH}$	2.5		ns	$CL \leq 20$ pF
Signal rise time	$t_{RISE}$		3	ns	$CL \leq 20$ pF
Signal fall time	$t_{FALL}$		3	ns	$CL \leq 20$ pF
<b>Input DAT (referenced to CLK-DDR mode)</b>					
Input set-up time	$t_{ISUddr}$	2.5		ns	$CL \leq 20$ pF
Input hold time	$t_{IHddr}$	2.5		ns	$CL \leq 20$ pF
<b>Outputs DAT (referenced to CLK-DDR mode)</b>					
Output delay time during data transfer	$t_{ODLYddr}$	1.5	7	ns	$CL \leq 20$ pF
Signal rise time(DAT0-7) <sup>(2)</sup>	$t_{RISE}$		2	ns	$CL \leq 20$ pF
Signal fall time (DAT0-7)	$t_{FALL}$		2	ns	$CL \leq 20$ pF

[Table 11] Dual data rate interface timings

- **NOTE 1.** CLK timing is measured at 50% of VDD.
- **NOTE 2.** Inputs DAT rising and falling times are measured by min ( $V_{IH}$ ) and max ( $V_{IL}$ ), and outputs CMD, DAT rising and falling times are measured by min ( $V_{OH}$ ) and max ( $V_{OL}$ )

## 5.2 Bus signal

### 5.2.1 Bus signal line load

The total capacitance  $C_L$  of each line of e-MMC bus is the sum of the bus master capacitance  $C_{HOST}$ , the bus capacitance  $C_{BUS}$  itself, and the capacitance  $C_{DEVICE}$  of the eMMC connected to this line, and requiring the sum of the host and bus capacitances not to exceed 20 pF.

$$C_L = C_{HOST} + C_{BUS} + C_{DEVICE}$$

Parameter	Symbol	Min	Typ	Max	Unit	Remark
Pull-up resistance for CMD	$R_{CMD}$	4.7		100	Kohm	to prevent bus floating
Pull-up resistance for DAT0-7	$R_{DAT}$	10		100	Kohm	to prevent bus floating
Internal pull up resistance DAT1 - DAT7	$R_{INT}$	10		150	Kohm	
Bus signal line capacitance	$C_L$			30	pF	Single Device
Single Device capacitance	$C_{DEVICE}$			6	pF	
Maximum signal line inductance				16	nH	$f_{pp} \leq 52$ MHz
VDDi capacitor value	$C_{REG}$	0.1			$\mu$ F	To stabilize regulator output when target device bus speed mode is either backward-compatible, high speed SDR, high speed DDR, or HS200.
		1			$\mu$ F	To stabilize regulator output when target device bus speed mode is HS400
$V_{CCQ}$ decoupling capacitor	$C_{H1}$	1			$\mu$ F	

[Table 12] e-NAND capacitance



### 5.2.2 Overshoot / Undershoot specification

Specification		$V_{CCQ}$		Unit
		1.70V - 1.95V		
Maximum peak amplitude allowed for overshoot area.	Max	0.9		V
Maximum peak amplitude allowed for undershoot area.	Max	0.9		V
Maximum area above $V_{CCQ}$	Max	1.5		V-ns
Maximum area below $V_{SSQ}$	Max	1.5		V-ns

[Table 13] Overshoot / Undershoot specification

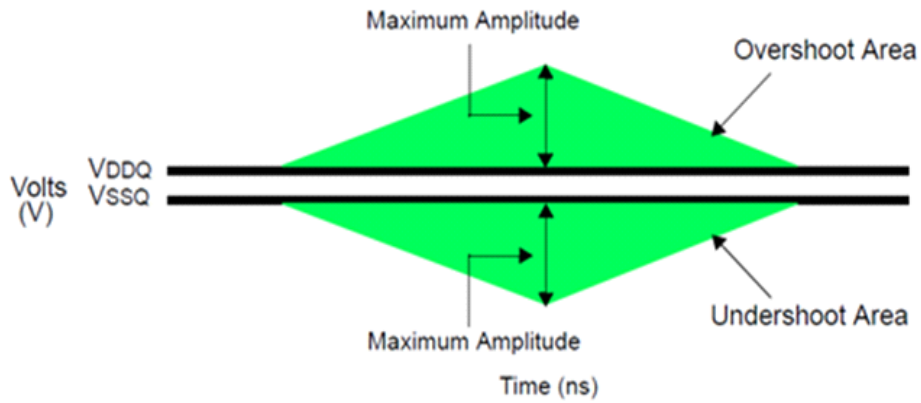

[Figure 16] Overshoot / Undershoot definition

### 5.2.3 Bus Signal levels

As the bus can be supplied with a variable supply voltage, all signal levels are related to the supply voltage.

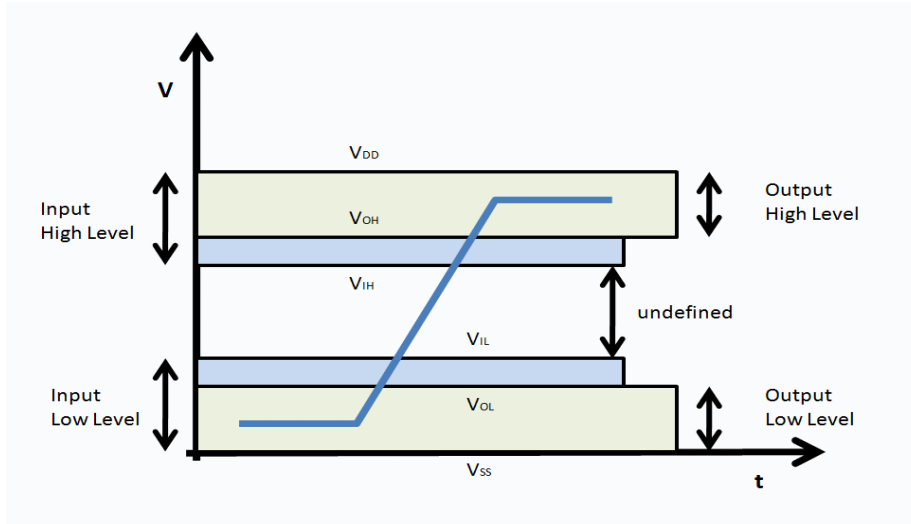

[Figure 17] e-NAND bus signal level

#### • Open-Drain mode bus signal level

Parameter	Symbol	Min.	Max.	Unit	Conditions
Output high voltage	$V_{OH}$	$V_{DD} - 0.2$		V	Note <sup>1)</sup>
Output low voltage	$V_{OL}$		0.3	V	$I_{OL} = 2\text{mA}$

[Table 14] Open-Drain signal level

- **NOTE 1.** Because  $V_{OH}$  depends on external resistance value (including outside the package), this value does not apply as device specification. Host is responsible to choose the external pull-up and open drain resistance value to meet  $V_{OH}$  minimum value.

• **Push-Pull mode bus signal level**

The device input and output voltages shall be within the following specified ranges for any  $V_{DD}$  of the allowed voltage range

Parameter	Symbol	Min.	Max.	Unit	Conditions
Output HIGH voltage	$V_{OH}$	$0.75 * V_{CCQ}$		V	$I_{OH} = -100\mu A @ V_{CCQ} \text{ min}$
Output LOW voltage	$V_{OL}$		$0.125 * V_{CCQ}$	V	$I_{OL} = -100\mu A @ V_{CCQ} \text{ min}$
Input HIGH voltage	$V_{IH}$	$0.625 * V_{CCQ}$	$V_{CCQ} + 0.3$	V	
Input LOW voltage	$V_{IL}$	$V_{SS} - 0.3$	$0.25 * V_{CCQ}$	V	

**[Table 15] Push-Pull signal level 2.7V-3.6V  $V_{CCQ}$  range**

Parameter	Symbol	Min.	Max.	Unit	Conditions
Output HIGH voltage	$V_{OH}$	$V_{CCQ} - 0.45V$		V	$I_{OH} = -2mA$
Output LOW voltage	$V_{OL}$		0.45V	V	$I_{OL} = -2mA$
Input HIGH voltage	$V_{IH}$	$0.65 * V_{CCQ}$	$V_{CCQ} + 0.3$	V	
Input LOW voltage	$V_{IL}$	$V_{SS} - 0.3$	$0.35 * V_{CCQ}$	V	

**[Table 16] Push-pull signal level 1.65V-1.95V  $V_{CCQ}$  range**

## 5.3 Power mode

### 5.3.1 e-NAND power-up guidelines

e-NAND power-up must adhere to the following guidelines:

- When power-up is initiated, either  $V_{cc}$  or  $V_{ccq}$  can be ramped up first, or both can be ramped up simultaneously.
- After power up, e-NAND enters the pre-idle state. The power up time of each supply voltage should be less than the specified tPRUH, tPRUL or tPRUV) for the appropriate voltage range.
- If e-NAND does not support boot mode or its BOOT\_PARTITION\_ENABLE bit is cleared, e-NAND moves immediately to the idle state. While in the idle state, e-NAND ignores all bus transactions until receiving CMD1. e-NAND begins boot operation with the argument of 0xFFFFFFFF. If boot acknowledge is finished, e-NAND shall send acknowledge pattern "010" to the host within the specified time. After boot operation is terminated, e-NAND enters the idle state and shall be ready for CMD1 operation. If e-NAND receives CMD1 in the pre-boot state, it begins to respond to the command and moves to the card identification mode.
- When e-NAND is initiated by alternative boot command(CMD0 with arg=0xFFFFFFFF), all the data will be read from the boot partition and then e-NAND automatically goes to idle state, but hosts are still required to issue CMD0 with arg=0x00000000 in order to complete a boot mode properly and move to the idle state. While in the idle state, e-NAND ignores all bus transactions until it receives CMD1.
- CMD1 is a special synchronization command which is used to negotiate the operating voltage range and poll the device until it is out of its power-up sequence. In addition to the operating voltage profile of the device, the response to CMD1 contains a busy flag indicating that the device is still working on its power-up procedure and is not ready for identification. This bit informs the host that the device is not ready, and the host must wait until this bit is cleared. The device must complete its initialization within 1 second of the first CMD1 issued with a valid OCR range.
- If the e-NAND device was successfully partitioned during the previous power up session (bit 0 of EXT\_CSD byte [155] PARTITION\_SETTING\_COMPLETE successfully set) then the initialization delay is (instead of 1s) calculated from INI\_TIMEOUT\_PA (EXT\_CSD byte [241]). This timeout applies only for the very first initialization after successful partitioning. For all the consecutive initialization 1sec time out will be applied.
- The bus master moves the device out of the idle state. Because the power-up time and the supply ramp-up time depend on the application parameters such as the bus length and the power supply unit, the host must ensure that power is built up to the operating level (the same level that will be specified in CMD1) before CMD1 is transmitted.
- After power-up, the host starts the clock and sends the initializing sequence on the CMD line. The sequence length is the longest of: 1ms, 74 clocks, the supply ramp-up time, or the boot operation period. An additional 10 clocks (beyond the 64 clocks of the power-up sequence) are provided to eliminate power-up synchronization problems.
- Every bus master must implement CMD1.

### 5.3.2 e-NAND Power Cycling

The master can execute any sequence of  $V_{CC}$  and  $V_{CCQ}$  power-up/power-down. However, the master must not issue any commands until  $V_{CC}$  and  $V_{CCQ}$  are stable within each operating voltage range. After the slave enters sleep mode, the master can power-down  $V_{CC}$  to reduce power consumption. It is necessary for the slave to be ramped up to  $V_{CC}$  before the host issues CMD5 (SLEEP\_AWAKE) to wake the slave unit.

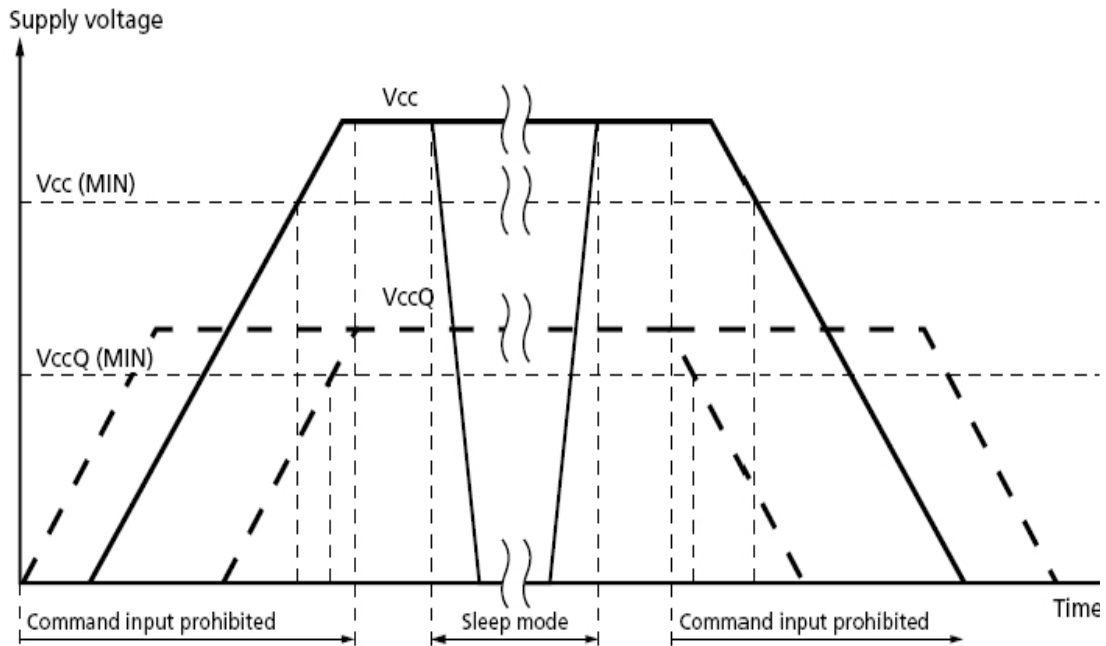

[Figure 18] e-NAND power cycle

If  $V_{CC}$  or  $V_{CCQ}$  is below 0.5 V for longer than 1 ms, the slave shall always return to the pre-idle state, and perform the appropriate boot behavior. The slave will behave as in a standard power up condition once the voltages have returned to their functional ranges. An exception to this behavior is if the device is in sleep state, in which the voltage on  $V_{CC}$  is not monitored.

### 5.3.3 Leakage

Parameter	Symbol	Min	Max.	Unit	Remark
	BGA	-0.5	$V_{CCQ}+0.5$	V	
<b>All inputs</b>					
Input leakage current (before initialization sequence and/or the internal pull up resistors connected)		-100	100	$\mu$ A	
<b>All outputs</b>					
Output leakage current (before initialization sequence)		-100	100	$\mu$ A	
Output leakage current (after initialization sequence)		-2	2	$\mu$ A	

[Table 17] General operation conditions

### 5.3.4 Power Supply

e-NAND supports one or more combinations of  $V_{CC}$  and  $V_{CCQ}$  as shown in Table 18.

The available voltage configuration is shown in Table 19.

Parameter	Symbol	Min	Max.	Unit	Remark
Supply voltage (NAND)	$V_{CC}$	2.7	3.6	V	
Supply voltage (I/O)	$V_{CCQ}$	1.7	1.95	V	
Supply power-up for 3.3V	$t_{PRUH}$		35	ms	
Supply power-up for 1.8V	$t_{PRUL}$		25	ms	

[Table 18] e-NAND power supply voltage

Parameter		$V_{CCQ}$
		1.7V - 1.95V
$V_{CC}$	2.7V - 3.6V	Valid
	1.7V - 1.95V	Not Valid

[Table 19] e-NAND voltage combinations

- NOTE 1.  $V_{CCQ}$ (I/O) 3.3 volt range is not supported in either HS200 or HS400 devices

## 5.4 Connection Guide

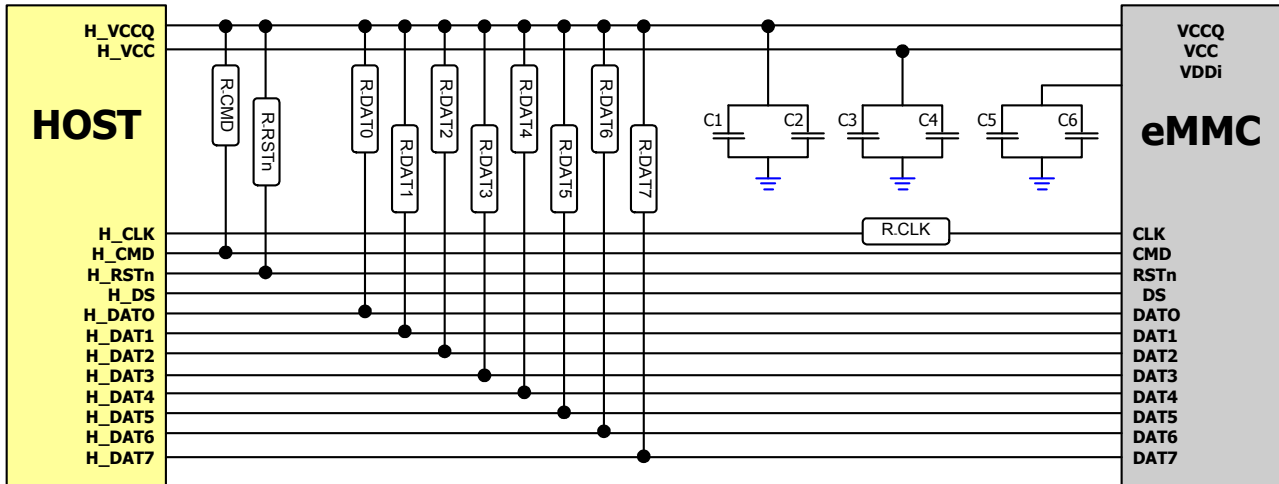

[Figure 19] Connection guide drawing

Parameter	Symbol	Min	Max	Recommend	Unit	Remark
Pull-up resistance for CMD	R_CMD	4.7	100	10	kohm	Pull-up resistance should be put on CMD line to prevent bus floating.
Pull-up resistance for DAT0~7	R_DAT	10	100	50	kohm	Pull-up resistance should be put on DAT line to prevent bus floating.
Data strobe(DS)	R_DS	NC	NC	NC	-	It is not necessary to put pull-up/pull-down resistance on DS line since DS is internally pulled down. Direct connection to host is required and please float this pin if it is not used
Pull-up resistance for RSTn	R_RSTn	10	100	50	kohm	It is not necessary to put pull-up resistance on RSTn line if host does not use H/W reset. (Extended CSD register [162] = 0b)
Serial resistance on CLK	R_CLK	0	30	27	ohm	To reduce overshooting/undershooting Note: If the host uses HS200, we recommend to remove this resistor for better CLK signal
V <sub>CCQ</sub> capacitor value	C1 & C2	2±0.22	4.7	2±0.22	μF	Coupling cap should be connected with V <sub>CCQ</sub> closely.
V <sub>CC</sub> capacitor value(≤8GB)	C3 & C4	4.72±10%	10	4.72±10%	μF	Coupling cap should be connected with V <sub>CC</sub> closely. V <sub>CC</sub> / V <sub>CCQ</sub> cap. value would be up to Host requirement and the application system characteristics.
V <sub>CC</sub> capacitor value(>8GB)						
VDDi capacitor value	C5 & C6	0	2.2	0.1	μF	Coupling cap should be connected with VDDi and Vssq as closely possible. (Internal Cap : 1μF)

[Table 20] Connection guide specification

## 6. e-NAND basic operations

### 6.1 Partitioning

#### 6.1.1 User density

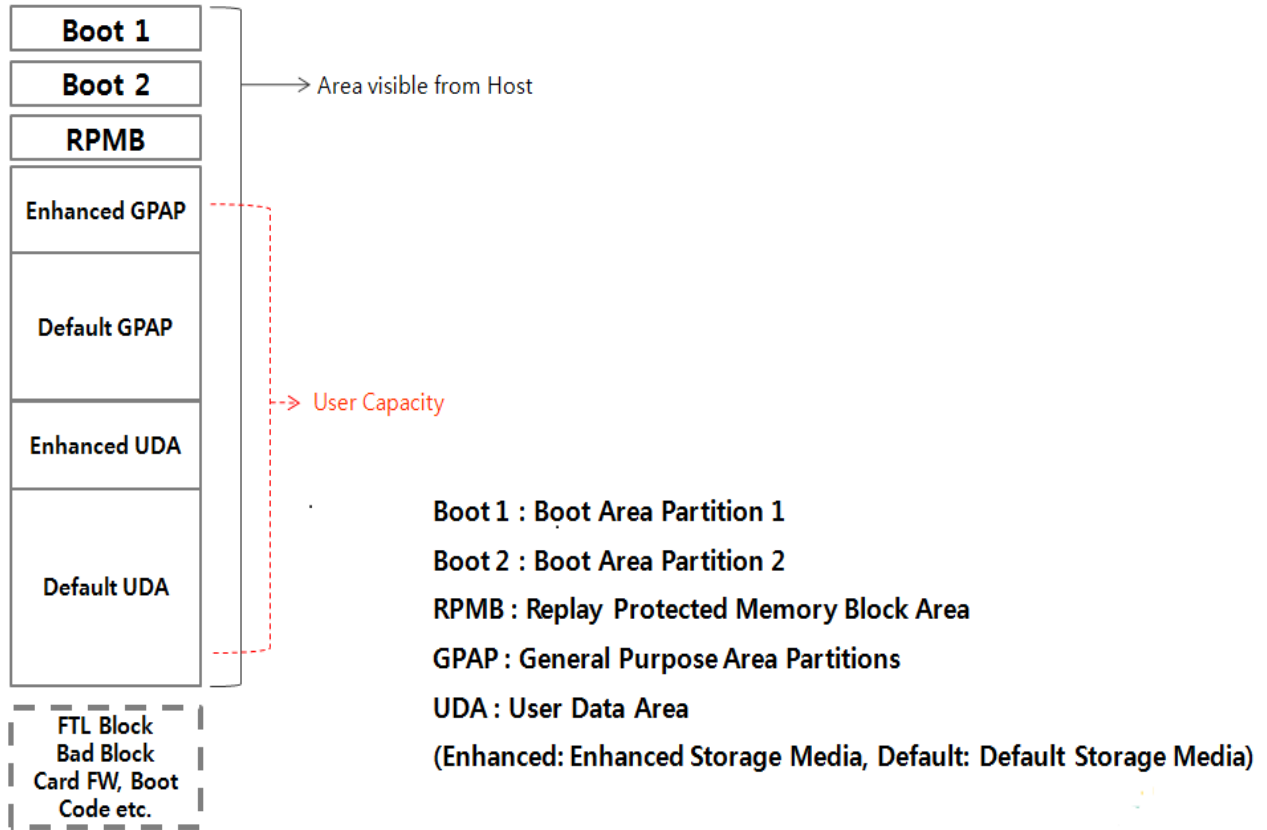

[Figure 20] Partition diagram

#### ■ Boot and RPMB partition size

Density	Boot 1,2 partition size	RPMB partition size
16GB	4096KB (4MB)	16384KB (16MB)
32GB		
64GB		



### ■ Boot and RPMB partition size

Capacity	SEC_COUNT	Capacity	Percentile
<b>16GB</b>	30,777,344 (0x1D5A000)	15,758,000,128 Bytes (14.68GB)	91.72%
<b>32GB</b>	61,071,360 (0x3A3E000)	31,268,536,320 Bytes (29.12GB)	91.00%
<b>64GB</b>	122,142,720 (0x747C000)	62,537,072,640 Bytes (58.24GB)	91.00%

- 1sector=512 bytes.
- The total usable capacity of the e-NAND may be less than total physical capacity because a small portion of the capacity is used for NAND flash management and maintenance purpose.

### ■ Maximum enhanced partition size

Enhanced user data area can be configured to store read-centric data such as sensitive data or for other host usage models. SK hynix e-NAND supports Enhanced User Data Area as SLC Mode. When customer adopts some portion as enhanced user data area in User Data Area, that area occupies double the size of the original set-up size.

Capacity	MAX_ENH_SIZE_MULT	HC_ERASE_GRP_SIZE	HC_WP_GRP_SIZE
<b>16GB</b>	0x0003AB	1h	10h
<b>32GB</b>	0x000747	1h	10h
<b>64GB</b>	0x000E8F	1h	10h

- Max Enhanced Partition Size is defined as **MAX\_ENH\_SIZE\_MULT x HC\_WP\_GRP\_SIZE x HC\_ERASE\_GRP\_SIZE x 512KByte**.

Capacity	Capacity (KB)
<b>16GB</b>	7,692,288
<b>32GB</b>	15,261,696
<b>64GB</b>	30,531,584

### 6.1.2 Erase / Write protect group size

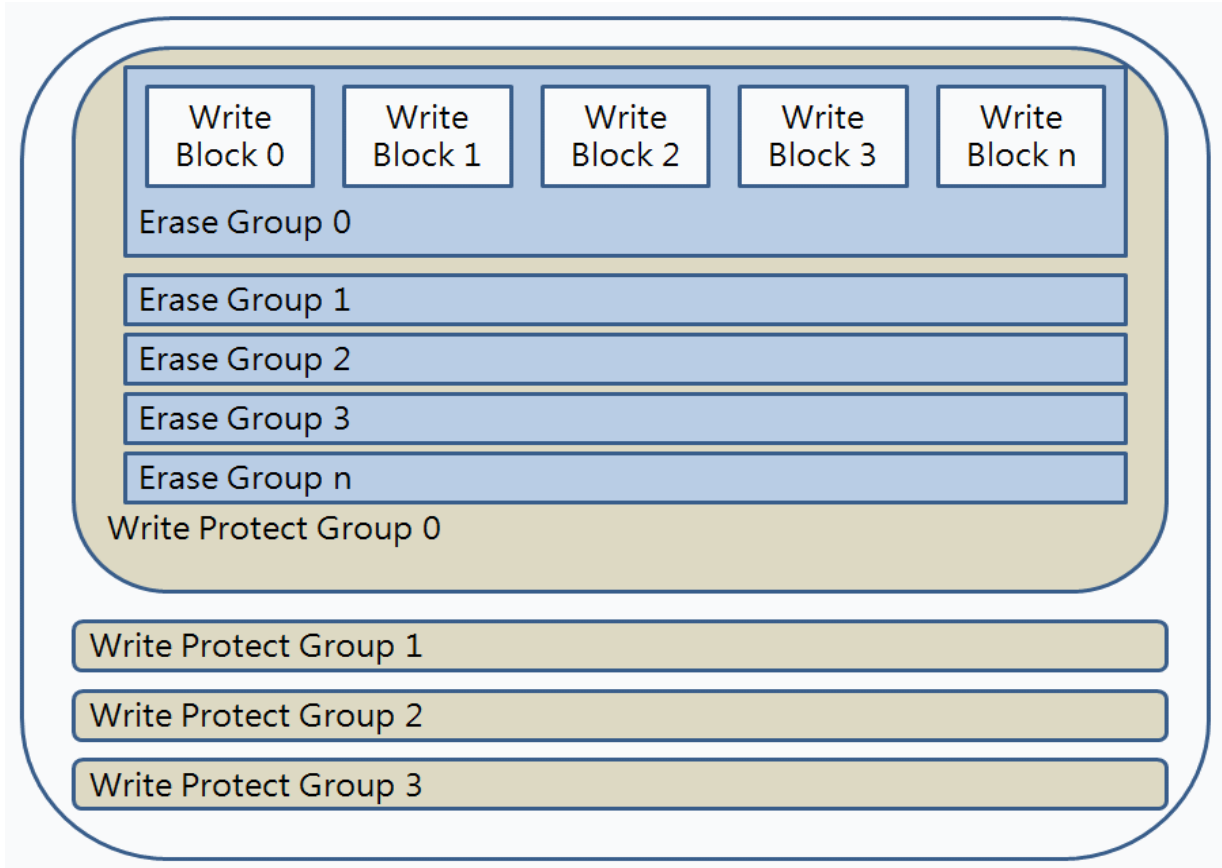

Density	Erase group size		Write protect group size
	ERASE_GROUP_DEF=0	ERASE_GROUP_DEF=1	
<b>16GB</b>	512KB	512KB	8MB
<b>32GB</b>	512KB	512KB	8MB
<b>64GB</b>	512KB	512KB	8MB

[Table 21] Erase/Write protect Group size

## 6.2 Boot operation

e-NAND supports boot mode and alternative boot mode. e-NAND also, supports high speed timing and dual data rate during boot.

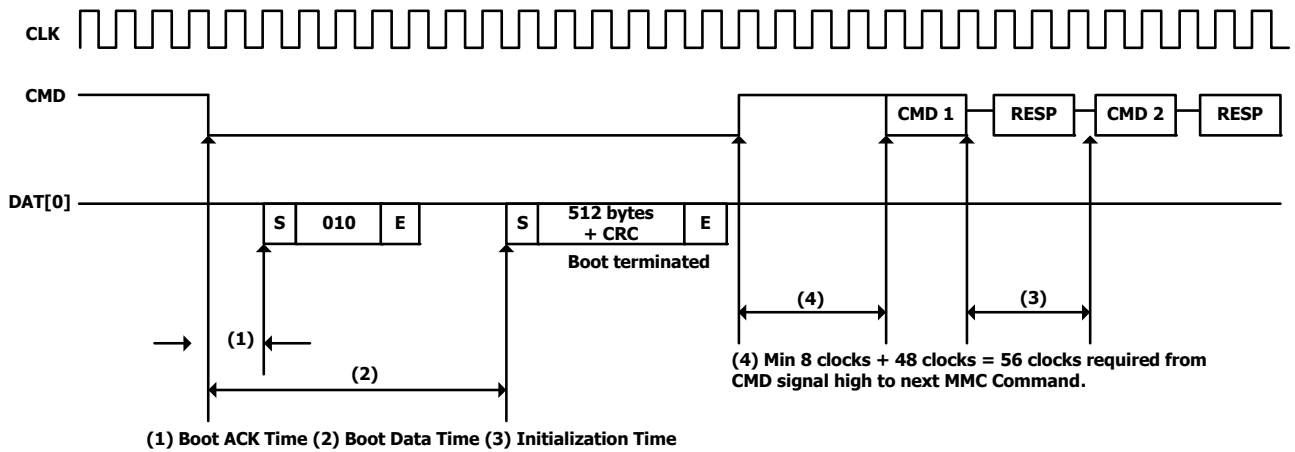

[Figure 21] e-NAND state diagram (Boot mode)

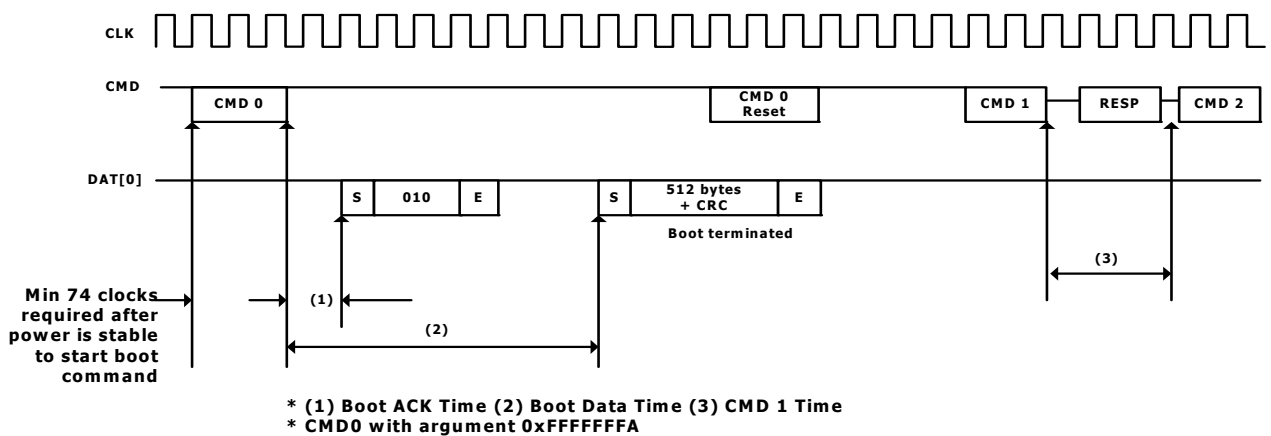

[Figure 22] e-NAND state diagram (Alternative boot mode)

Timing Factor	Value
(1) Boot ACK Time	< 50 ms
(2) Boot Data Time	< 1 sec
(3) Initialization Time	< 1 sec

- Initialization time includes partition setting, Please refer to INI\_TIMEOUT\_AP in 7.4 Extended CSD Register. Initialization time is completed within 1sec from issuing CMD1 until receiving response.
- The device has to send the acknowledge pattern "010" to the master within 50ms after the CMD0 with the argument of 0xFFFFFFFF is received.

## 7. Time out

Latency Item	Value	Remark
<b>Write Time out (CMD To 512KB Write Done)</b>	Max 1.2s Median 30ms 99th 50ms	
<b>Write Time out (Data To Data)</b>	Max 500ms	
<b>Read Time Out (CMD To the first data out)</b>	Max 50ms	
<b>Initialization Time</b>	Max 1s	
<b>Initialization Time (After Partitioning)</b>	Max 1s	
<b>Initialization after PON (Short/long)</b>	Max 180ms	
<b>Pre-Boot to ACK</b>	Max 50ms	
<b>Pre-Boot to Boot Data</b>	Max 60ms	
<b>Partition Switch</b>	Max 10ms	
<b>CMD6 Switch</b>	Max 100ms	
<b>CMD8 time out</b>	Max 5ms	
<b>Erase (Erase Group)</b>	Max 600ms	
<b>Trim (512B~512KB)</b>	Max 600ms	
<b>Discard (512B~512KB)</b>	Max 600ms	

[Table 22] Time out value

Latency Item	Value		Remark
Secure Trim1 Type 0, 1 (512B~512KB)	Max 600s		Type 0 : information removed by an erase of the physical memory Type 1 : Same operation to type 0 Type 2 : Not support Type 3 : information unmapped
Secure Trim1 Type 3 (512B~512KB)	Max 600ms		
Secure Erase Type 0,1 (Write Block 512KB)	Max 600s		
Secure Erase Type 3 (Write Block 512KB)	Max 600ms		
Sanitize (UDA Area)	16GB	Max 80min	
	32GB	Max 80min	
	64GB	Max 80min	
Force Erase (UDA Area)	Max 3min		
HPI	Max 100ms		
PON Busy Time (Short/Long)	Max 50ms / 600ms		PON long includes GC PON short not include GC

**[Table 22] Time out value (Continue)**

- Be advised timeout values specified in table above are for testing purpose under SK hynix test pattern only and actual timeout situations may vary

## 8. Device registers

There are six different registers within the device interface:

- Operation conditions register (OCR)
- Card identification register (CID)
- Card specific data register (CSD)
- Relative card address register (RCA)
- DSR (Driver Stage Register)
- Extended card specific data register (EXT\_CSD).

These registers are used for the serial data communication and can be accessed only using the corresponding commands. e-NAND has a status register to provide information about the current device state and completion codes for the last host command.

### 8.1 Operation conditions register (OCR)

The 32-bit operation conditions register (OCR) stores the VDD voltage profile of e-NAND and the access mode indication. In addition, this register includes a status information bit. This status bit is set if e-NAND power up procedure has been finished.

OCR bit	Description	SK hynix e-NAND
[6:0]	Reserved	000 0000b
[7]	1.70 - 1.95V	1b
[14:8]	2.0 - 2.6	000 0000b
[23:15]	2.7 - 3.6 (High $V_{CCQ}$ range)	1111 1111 1b
[28:24]	Reserved	0 0000b
[30:29]	Access mode	10b (sector mode)
[31]	(card power up status bit (busy)) <sup>(1)</sup>	

**[Table 23] OCR register definition**

- NOTE 1. This bit is set to LOW if the card has not finished the power up routine

## 8.2 Card identification (CID) register

The card identification (CID) register is 128 bits wide. It contains e-NAND identification information used during e-NAND identification phase (e-NAND protocol). Every individual e-NAND has a unique identification number. The structure of the CID register is defined in the following sections.

Name	Field	Width	CID slice	CID value	Remark
Manufacturer ID	MID	8	[127:120]	0X90	
Reserved		6	[119:114]		
Card/BGA	CBX	2	[113:112]	0X1	BGA
OEM/application ID	OID	8	[111:104]	0X4A	
Product name	PNM	48	[103:56]	16GB: 0X68413861503E 32GB: 0X68423861503E 64GB: 0X68433861503E	
Product revision	PRV	8	[55:48]	-	Not fixed
Product serial number	PSN	32	[47:16]	-	1)
Manufacturing date	MDT	8	[15:8]	-	
CRC7 checksum	CRC	7	[7:1]	-	
Not used, always '1'		1	[0:0]	0X1	

1) If PSN is to be used as a Unique ID, a composition PSN and MDT should be used.  
Whole CID can also be used to generate a unique ID

**[Table 24] Card identification (CID) fields**

### 8.3 Card specific data register (CSD)

The card specific data (CSD) register provides information on how to access e-NAND contents. The CSD defines the data format, error correction type, maximum data access time, data transfer speed and so on. The programmable part of the register (entries marked by W or E, see below) can be changed by CMD27. The type of the CSD Registry entries in the Table 25 below is coded as follows:

- R: Read only.
- W: One time programmable and not readable.
- R/W: One time programmable and readable.
- W/E: Multiple writable with value kept after power failure, H/W reset assertion and any CMD0 reset and not readable.
- R/W/E: Multiple writable with value kept after power failure, H/W reset assertion and any CMD0 reset and readable.
- R/W/C\_P: Writable after value cleared by power failure and HW/rest assertion (the value not cleared by CMD0 reset) and readable.
- R/W/E\_P: Multiple writable with value reset after power failure, H/W reset assertion and any CMD0 reset and readable.
- W/E\_P: Multiple writable with value reset after power failure, H/W reset assertion and any CMD0 reset and not readable.

Name	Field	Width	Cell type	CSD slice	CSD value	Remark
CSD structure	CSD_STRUCTURE	2	R	[127:126]	0X03	
System specification version	SPEC_VERS	4	R	[125:122]	0X04	
Reserved		2	R	[121:120]		
Data read access-time 1	TAAC	8	R	[119:112]	0X5E	
Data read access-time 2 in CLK cycles (NSAC*100)	NSAC	8	R	[111:104]	0X00	
Max. bus clock frequency	TRAN_SPEED	8	R	[103:96]	0X32	
Card command classes	CCC	12	R	[95:84]	0X8F5	
Max. read data block length	READ_BL_LEN	4	R	[83:80]	0X09	
Partial blocks for read allowed	READ_BL_PARTIAL	1	R	[79:79]	0X00	
Write block misalignment	WRITE_BLK_MISALIGN	1	R	[78:78]	0X00	
Read block misalignment	READ_BLK_MISALIGN	1	R	[77:77]	0X00	
DSR implemented	DSR_IMP	1	R	[76:76]	0X00	
Reserved		2	R	[75:74]		
Device size	C_SIZE	12	R	[73:62]	0XFFF	
Max. read current @ VDD min	VDD_R_CURR_MIN	3	R	[61:59]	0X07	
Max. read current @ VDD max	VDD_R_CURR_MAX	3	R	[58:56]	0X07	
Max. write current @ VDD min	VDD_W_CURR_MIN	3	R	[55:53]	0X07	
Max. write current @ VDD max	VDD_W_CURR_MAX	3	R	[52:50]	0X07	
Device size multiplier	C_SIZE_MULT	3	R	[49:47]	0X07	
Erase group size	ERASE_GRP_SIZE	5	R	[46:42]	0X1F	
Erase group size multiplier	ERASE_GRP_MULT	5	R	[41:37]	0X1F	

[Table 25] CSD fields



Name	Field	Width	Cell type	CSD slice	CSD value	Remark
Write protect group size	WP_GRP_SIZE	5	R	[36:32]	0x0F	
Write protect group enable	WP_GRP_ENABLE	1	R	[31:31]	0X01	
Manufacturer default ECC	DEFAULT_ECC	2	R	[30:29]	0X00	
Write speed factor	R2W_FACTOR	3	R	[28:26]	0X03	
Max. write data block length	WRITE_BL_LEN	4	R	[25:22]	0X09	
Partial blocks for write allowed	WRITE_BL_PARTIAL	1	R	[21:21]	0X00	
Reserved		4	R	[20:17]		
Content protection application	CONTENT_PROT_APP	1	R	[16:16]	0X00	
File format group	FILE_FORMAT_GRP	1	R/W	[15:15]	0X00	
Copy flag (OTP)	COPY	1	R/W	[14:14]	0X00	
Permanent write protection	PERM_WRITE_PROTECT	1	R/W	[13:13]	0X00	
Temporary write protection	TMP_WRITE_PROTECT	1	R/W/E	[12:12]	0X00	
File format	FILE_FORMAT	2	R/W	[11:10]	0X00	
ECC code	ECC	2	R/W/E	[9:8]	0X00	
CRC	CRC	7	R/W/E	[7:1]	-	Not fixed
Not used, always `1`		1		[0:0]	0X01	

**[Table 25] CSD fields (Continued)**

The following sections describe the CSD fields and the relevant data types. If not explicitly defined otherwise, all bit strings are interpreted as binary coded numbers starting with the left bit first.

## 8.4 Extended CSD register

The Extended CSD register defines e-NAND properties and selected modes. It is 512 bytes long. The most significant 320 bytes are the Properties segment, which defines e-NAND capabilities and cannot be modified by the host. The lower 192 bytes are the modes segment, which defines the configuration e-NAND is working in. These modes can be changed by the host by means of the switch command.

Name	Field	CSD slice	Cell Type	CSD value	Remark
<b>Properties segment</b>					
Reserved		[511:506]			
Extended Security Commands Error	EXT_SECURITY_ERR	[505]	R	0x00	
Supported command sets	S_CMD_SET	[504]	R	0x01	
HPI features	HPI_FEATURES	[503]	R	0x01	
Background operations support	BKOPS_SUPPORT	[502]	R	0x01	
Max packed read commands	MAX_PACKED_READS	[501]	R	0x3F	
Max packed write commands	MAX_PACKED_WRITES	[500]	R	0x3F	
Data Tag Support	DATA_TAG_SUPPORT	[499]	R	0x01	
Tag Unit Size	TAG_UNIT_SIZE	[498]	R	0x00	
Tag Resources Size	TAG_RES_SIZE	[497]	R	0x00	
Context management capabilities	CONTEXT_CAPABILITIES	[496]	R	0x05	
Large Unit size	LARGE_UNIT_SIZE_M1	[495]	R	0x01	
Extended partitions attribute support	EXT_SUPPORT	[494]	R	0x03	
Supported modes	SUPPORTED_MODES	[493]	R	0x01	
FFU features	FFU_FEATURES	[492]	R	0x00	
Operation codes timeout	OPERATION_CODE_TIMEOUT	[491]	R	0x00	
FFU Argument	FFU_ARG	[490:487]	R	0xFFFFFFF0	
<b>Barrier support</b>	BARRIER_SUPPORT	[486]	R	0x01	
Reserved		[485:309]			
<b>CMD Queuing Support</b>	<b>CMDQ_SUPPORT</b>	<b>[308]</b>	R	<b>0x01</b>	
<b>CMD Queuing Depth</b>	<b>CMDQ_DEPTH</b>	<b>[307]</b>	R	<b>0x1F</b>	
Reserved		[306]			
Number of FW sectors correctly programmed	NUMBER_OF_FW_SECTORS_CORRECTLY_PROGRAMMED	[305:302]	R	0x00000000	
Vendor proprietary health report	VENDOR_PROPRIETARY_HEALTH_REPORT	[301:270]	R	-	

[Table 26] Extended CSD

Name	Field	CSD slice	Cell Type	CSD value	Remark
Device life time estimation type B	DEVICE_LIFE_TIME_EST_TYP_B	[269]	R	Variable	
Device life time estimation type A	DEVICE_LIFE_TIME_EST_TYP_A	[268]	R	Variable	
Pre EOL information	PRE_EOL_INFO	[267]	R	0x01	
Optimal read size	OPTIMAL_READ_SIZE	[266]	R	0x20	
Optimal write size	OPTIMAL_WRITE_SIZE	[265]	R	0x20	
Optimal trim unit size	OPTIMAL_TRIM_UNIT_SIZE	[264]	R	0x01	
Device version	DEVICE_VERSION	[263:262]	R	16GB : 0x410E 32GB : 0x420E 64GB : 0x430E	
Firmware version	FIRMWARE_VERSION	[261:254]	R	-	Not fixed
Power class for 200MHz, DDR at Vcc=3.6V	PWR_CL_DDR_200_360	[253]	R	0x04	
Cache size	CACHE_SIZE	[252:249]	R	0x00000800	
Generic CMD6 timeout	GENERIC_CMD6_TIME	[248]	R	0x0A	
Power off Notification (long) timeout	POWER_OFF_LONG_TIME	[247]	R	0x3C	
Background operations status	BKOPS_STATUS	[246]	R	0x00	
Number of correctly programmed sectors	CORRECTLY_PRG_SECTORS_NUM	[245:242]	R	-	Not fixed
1st initialization time after partitioning	INI_TIMEOUT_AP	[241]	R	0x0A	
Cache Flushing Policy	CACHE_FLUSH_POLICY	[240]	R	0x01	
Power class for 52MHz, DDR at Vcc=3.6V	PWR_CL_DDR_52_360	[239]	R	0x00	
Power class for 52MHz, DDR at Vcc=1.95V	PWR_CL_DDR_52_195	[238]	R	0x00	Not support
Power class for 200MHz at Vccq=1.95, Vcc=3.6V	PWR_CL_200_195	[237]	R	0x00	
Power class for 200MHz at Vccq=1.3, Vcc=3.6V	PWR_CL_200_130	[236]	R	0x00	Not support
Minimum write performance for 8bit at 52MHz in DDR mode	MIN_PERF_DDR_W_8_52	[235]	R	0x00	
Minimum read performance for 8bit at 52MHz in DDR mode	MIN_PERF_DDR_R_8_52	[234]	R	0x00	
Reserved		[233]			
TRIM multiplier	TRIM_MULT	[232]	R	0x02	
Secure feature support	SEC_FEATURE_SUPPORT	[231]	R	0x55	
Secure erase multiplier	SEC_ERASE_MULT	[230]	R	0xFA	
Secure TRIM multiplier	SEC_TRIM_MULT	[229]	R	0xFA	

[Table 26] Extended CSD(Continued)

Name	Field	CSD slice	Cell Type	CSD value	Remark
Boot information	BOOT_INFO	[228]	R	0x07	
Reserved		[227]			
Boot partition size	BOOT_SIZE_MULTI	[226]	R	0x20	
Access size	ACC_SIZE	[225]	R	0x07	
High-capacity erase unit size	HC_ERASE_GRP_SIZE	[224]	R	0x01	
High-capacity erase timeout	ERASE_TIMEOUT_MULT	[223]	R	0x02	
Reliable write sector count	REL_WR_SEC_C	[222]	R	0x01	
High-capacity write protect group size	HC_WP_GRP_SIZE	[221]	R	0x10	
Sleep current(Vcc)	S_C_Vcc	[220]	R	0x08	
Sleep current(Vccq)	S_C_Vccq	[219]	R	0x09	
Production state awareness timeout	PRODUCTION_STATE_AWARENES S_TIMEOUT	[218]	R	0x0A	
Sleep/awake timeout	S_A_TIMEOUT	[217]	R	0x15	
Sleep Notification Timeout	SLEEP_NOTIFICATION_TIME	[216]	R	0x0E	
Sector count	SEC_COUNT	[215:212]	R	16GB: 0X1D5A000 32GB: 0X03A3E000 64GB: 0X747C000	
<b>Secure Write Protect information</b>	<b>SECURE_WP_INFO</b>	<b>[211]</b>	<b>R</b>	<b>0x01</b>	
Minimum write performance for 8bit at 52MHz	MIN_PERF_W_8_52	[210]	R	16GB: 0X3C 32GB: 0x78 64GB: 0X8C	
Minimum read performance for 8bit at 52MHz	MIN_PERF_R_8_52	[209]	R	0x8C	
Minimum write performance for 8bit at 26MHz, for 4bit at 52MHz	MIN_PERF_W_8_26_4_52	[208]	R	16GB: 0X3C 32GB/64GB: 0X46	
Minimum read performance for 8bit at 26MHz, for 4bit at 52MHz	MIN_PERF_R_8_26_4_52	[207]	R	0x46	
Minimum write performance for 4bit at 26MHz	MIN_PERF_W_4_26	[206]	R	0x1E	
Minimum read performance for 4bit at 26MHz	MIN_PERF_R_4_26	[205]	R	0x1E	
Reserved		[204]			
Power class for 26MHz at 3.6V	PWR_CL_26_360	[203]	R	0x00	
Power class for 52MHz at 3.6V	PWR_CL_52_360	[202]	R	0x00	
Power class for 26MHz at 1.95V	PWR_CL_26_195	[201]	R	0x00	Not support
Power class for 52MHz at 1.95V	PWR_CL_52_195	[200]	R	0x00	Not support

[Table 26] Extended CSD(Continued)

Name	Field	CSD slice	Cell Type	CSD value	Remark
Partition switching timing	PARTITION_SWITCH_TIME	[199]	R	0x01	
Out-of-interrupt busy timing	OUT_OF_INTERRUPT_TIME	[198]	R	0x0A	
I/O Driver Strength	DRIVER_STRENGTH	[197]	R	0x1F	
Device type	DEVICE_TYPE	[196]	R	0x57	
Reserved		[195]			
CSD structure	CSD_STRUCTURE	[194]	R	0x02	
Reserved		[193]			
Extended CSD revision	EXT_CSD_REV	[192]	R	0x08	
<b>Modes Segment</b>					
Command set	CMD_SET	[191]	R/W/E_P	0x00	
Reserved		[190]			
Command set revision	CMD_SET_REV	[189]	R	0x00	
Reserved		[188]			
Power class	POWER_CLASS	[187]	R/W/E_P	0x00	
Reserved		[186]			
High-speed interface timing	HS_TIMING	[185]	R/W/E_P	0x00	
Strobe Support	STROBE_SUPPORT	[184]	R	0x01	
Bus width mode	BUS_WIDTH	[183]	W/E_P	0x00	
Reserved		[182]			
Erased memory content	ERASED_MEM_CONT	[181]	R	0x00	
Reserved		[180]			
Partition configuration	PARTITION_CONFIG	[179]	R/W/E & R/W/E_P	0x00	
Boot config protection	BOOT_CONFIG_PROT	[178]	R/W/E & R/W/C_P	0x00	
Boot bus conditions	BOOT_BUS_CONDITIONS	[177]	R/W/E	0x00	
Reserved		[176]			
High-density erase group definition	ERASE_GROUP_DEF	[175]	R/W/E_P	0x00	
Boot write protection status registers	BOOT_WP_STATUS	[174]	R	0x00	
Boot area write protection register	BOOT_WP	[173]	R/W/E & R/W/C_P	0x00	
Reserved		[172]			

[Table 26] Extended CSD(Continued)

Name	Field	CSD slice	Cell Type	CSD value	Remark
User area write protection register	USER_WP	[171]	R/W, R/W/ C_P & /W/ E_P	0x00	
Reserved		[170]			
FW configuration	FW_CONFIG	[169]	R/W	0x00	
RPMB Size	RPMB_SIZE_MULT	[168]	R	0x80	
Write reliability setting register	WR_REL_SET	[167]	R/W	0x1F	
Write reliability parameter register	WR_REL_PARAM	[166]	R	0x15	
Sanitize start	SANITIZE_START	[165]	W/E_P	0x00	
Manually start background operations	BKOPS_START	[164]	W/E_P	0x00	
Enable background operations Handshake	BKOPS_EN	[163]	R/W	0x00	
H/W reset function	RST_n_FUNCTION	[162]	R/W	0x00	
HPI management	HPI_MGMT	[161]	R/W/E_P	0x00	
Partitioning support	PARTITIONING_SUPPORT	[160]	R	0x07	
Max enhanced area size	MAX_ENH_SIZE_MULT	[159:157]	R	16GB: 0X0003AB 32GB: 0X000747 64GB: 0X000E8F	
Partitions attribute	PARTITIONS_ATTRIBUTE	[156]	R/W	0x00	
Partitioning setting	PARTITION_SETTING_COMPLETED	[155]	R/W	0x00	
General purpose partition size	GP_SIZE_MULT	[154:143]	R/W	0x00...00	
Enhanced user data area size	ENH_SIZE_MULT	[142:140]	R/W	0x000000	
Enhanced user data start address	ENH_START_ADDR	[139:136]	R/W	0x00000000	
Reserved		[135]			
Bad Block management mode	SEC_BAD_BLK_MGMNT	[134]	R/W	0x00	
Production state awareness	PRODUCTION_STATE_AWARENESS	[133]	R/W/E	0x00	
Package Case Temperature is Controlled	TCASE_SUPPORT	[132]	W/E_P	0x00	
Periodic Wake-up	PERIODIC_WAKEUP	[131]	R/W/E	0x00	
Program CID/CSD in DDR mode support	PROGRAM_CID_CSD_DDR_SUPPORT	[130]	R	0x01	
Reserved		[129:128]			
Vendor Specific Fields	VENDOR_SPECIFIC_FIELD	[127:64]	Vendor specific		

**[Table 26] Extended CSD(Continued)**

Name	Field	CSD slice	Cell Type	CSD value	Remark
Native sector size	NATIVE_SECTOR_SIZE	[63]	R	0x01	
Sector size emulation	USE_NATIVE_SECTOR	[62]	R/W	0x00	
Sector size	DATA_SECTOR_SIZE	[61]	R	0x00	
1st initialization after disabling sector size emulation	INI_TIMEOUT_EMU	[60]	R	0x0A	
Class 6 commands control	Class6_CTRL	[59]	R/W/E_P	0x00	
Number of addressed group to be Released	DYNCAP_NEEDED	[58]	R	0x00	
Exception events control	EXCEPTION_EVENTS_CTRL	[57:56]	R/W/E_P	0x0000	
Exception events status	EXCEPTION_EVENTS_STATUS	[55:54]	R	0x0000	
Extended Partitions Attribute	EXT_PARTITIONS_ATTRIBUTE	[53:52]	R/W	0x0000	
Context configuration	CONTEXT_CONF	[51:37]	R/W/E_P	0x00...00	
Packed command status	PACKED_COMMAND_STATUS	[36]	R	0x00	
Packed command failure index	PACKED_FAILURE_INDEX	[35]	R	0x00	
Power Off Notification	POWER_OFF_NOTIFICATION	[34]	R/W/E_P	0x00	
Control to turn the Cache ON/OFF	CACHE_CTRL	[33]	R/W/E_P	0x00	
Flushing of the cache	FLUSH_CACHE	[32]	W/E_P	0x00	
Control to turn the barrier ON/OFF	BARRIER_CONTROL	[31]	R/W	0x00	
Mode config	MODE_CONFIG	[30]	R/W/E_P	0x00	
Mode operation codes	MODE_OPERATION_CODES	[29]	W/E_P	0x00	
Reserved		[28:27]			
FFU Status	FFU_STATUS	[26]	R	0x00	
Pre loading data size	PRE_LOADING_DATA_SIZE	[25:22]	R/W/E_P	0X00000000	
Max pre loading data size	MAX_PRE_LOADING_DATA_SIZE	[21:18]	R	16GB: 0x00EAD000 32GB: 0x01D1F000 64GB: 0x03A3E000	
Product state awareness enablement	PRODUCT_STATE_AWARENESS_ENABLEMENT	[17]	R/W/E & R	0x01	
Secure Removal Type	SECURE_REMOVAL_TYPE	[16]	R/W & R	0x0B	
Command Queue Mode Enable	CMDQ_MODE_EN	[15]	R/W/E_P	0x00	
Reserved		[14:0]			

[Table 26] Extended CSD(Continued)

- Reserved bits should read as "0"
- Obsolete values should be don't care

### **8.5 RCA (Relative card address)**

The writable 16-bit relative card address (RCA) register carries the card address assigned by the host during the card identification. This address is used for the addressed host-card communication after the card identification procedure. The default value of the RCA register is 0x0001. The value 0x0000 is reserved to set all cards into the Stand-by State with CMD7.

### **8.6 DSR (Driver stage register)**

It can be optionally used to improve the bus performance for extended operating conditions (depending on parameters like bus length, transfer rate or number of Devices). The CSD register carries the information about the DSR register usage. The default value of the DSR register is 0x404.



## X-ON Electronics

Largest Supplier of Electrical and Electronic Components

*Click to view similar products for eMMC category:*

*Click to view products by SK HYNIX manufacturer:*

Other Similar products are found below :

[SDINBDG4-8G-ZA2](#) [S40FC004C1B2I00300](#) [FEMDRW128G-88A19](#) [ZDEMDCM064G-95A8](#) [KLM8G1GEUF-B04P](#) [FEMDNN016G-A3A55](#) [FEMDMW016G-88A43](#) [FEMDMW064G-88A19](#) [FEMDRW016G-88A43](#) [FEMDME064G-A8A58](#) [THGAMRG7T13BAIL](#) [KLM8G1GETF-B041006](#) [KLMCG2UCTB-B041](#) [KLMCG2UCTA-B041](#) [H26M41208HPRA](#) [H26M51002KPR](#) [ZDEMMC16GA](#) [FEMDME032G-A8A58](#) [THGAMRG8T13BAIL](#) [SDINBDV4-32G](#) [SDDDC4DR-64G](#) [SDADA4DR-64G](#) [FEMDME004G-A8A39](#) [SDINBDG4-16G](#) [SDINBDG4-8G](#) [SDINBDG4-8G-XI1](#) [SDINBDG4-8G-I1](#) [SDINBDG4-16G-I1](#) [SDINADF4-16G-H](#) [SDINBDG4-32G](#) [SDINBDG4-8G-ZA](#) [SDINBDG4-64G-I1](#) [SFEM032GB1EA1TO-I-LF-111-STD](#) [SDINBDG4-32G-ZA](#) [SDINBDG4-32G-XA](#) [THGBMNG5D1LBAIT](#) [THGBMNG5D1LBAIL](#) [SDINBDG4-64G-XI1](#) [SDINADF4-128G](#) [SDINBDG4-64G-XA](#) [SDINBDG4-8G-XA](#) [SDINBDG4-32G-XI1](#) [SDINBDG4-16G-XA](#) [SDINBDA4-32G](#) [SDINBDG4-64G](#) [SDINBDG4-64G-ZA](#) [ASFC8G31M-51BIN](#) [ASFC4G31M-51BIN](#) [MTFC4GACAJCN-4M IT](#) [FEMDME008G-A8A39](#)