

SKYEMODULE GEMINI USER GUIDE

VERSION 10/06/2017

COPYRIGHT INFORMATION:

Copyright 2017 Novanta Corporation. All rights reserved.

Version 10/03/2017

This product or document is protected by copyright and distributed under licenses restricting its use, copying, distribution, and decompilation. No part of this product or document may be reproduced in any form by any means without prior written authorization of Novanta Corporation and its licensors, if any.

MIFARE and NXP is a registered trademark of Royal Philips Electronics.
Microsoft and Windows are registered trademarks of Microsoft Corporation.

TECHNICAL SUPPORT AND CONTACT INFORMATION

TELEPHONE: 315.701.0678

www.jadaktech.com

Email: RFID-support@jadaktech.com

TABLE OF CONTENTS

1	INTRODUCTION.....	7
1.1	GETTING STARTED	7
1.2	WHY A SKYTEK MODULE?	7
1.3	ADDITIONAL READING	8
1.4	REVISION HISTORY.....	9
2	DEFINITION OF TERMS	10
3	ORDERING INFORMATION	11
3.1	GEMINI STANDARD PART NUMBERS	11
3.2	PART NUMBER DETAILS	11
4	SKYEMODULE GEMINI OVERVIEW.....	12
4.1	DESCRIPTION.....	12
4.2	BLOCK DIAGRAM	12
4.3	FEATURES.....	13
4.4	APPLICATIONS.....	13
4.5	AGENCY APPROVALS	13
5	MECHANICAL SPECIFICATIONS	14
6	PINNING INFORMATION	15
6.1	CONNECTOR DESCRIPTIONS	15
6.2	HOST INTERFACE CONNECTOR PIN MAPPING.....	16
6.3	EXTERNAL ANTENNA CONNECTOR PIN MAPPING	17
6.4	USING THE GPIO PINS.....	18
7	ENVIRONMENTAL SPECIFICATIONS	19
7.1	ELECTROSTATIC PRECAUTIONS.....	19
7.2	GENERAL RATINGS AND OPERATING CONDITIONS	19
8	ELECTRICAL SPECIFICATIONS	20
8.1	ELECTRICAL CHARACTERISTICS	20
8.2	ABSOLUTE MAXIMUM RATINGS	21
9	PERFORMANCE SPECIFICATIONS	22
9.1	TIMING SPECIFICATIONS.....	22
9.2	RANGE SPECIFICATIONS.....	23
10	RADIO SPECIFICATIONS	24
10.1	AGENCY APPROVALS	24
10.2	EU DECLARATION OF CONFORMITY	24

- 10.3 HOST DEVICE LABELING FOR FCC..... 25
- 10.4 FREQUENCY BAND..... 25
- 10.5 TAG PROTOCOLS..... 25
- 11 HOST INTERFACE SPECIFICATIONS 26**
 - 11.1 USB 2.0.....27
 - 11.2 TTL SERIAL..... 28
 - 11.3 SPI 30
 - 11.4 I²C..... 33
- 12 SKYEMODULE GEMINI ANTENNA OPTIONS..... 36**
- 13 COMMUNICATING WITH THE MODULE 37**
 - 13.1 HOST COMMUNICATION (SKYTEK PROTOCOL V3)..... 37
 - 13.2 REQUEST FORMATS 37
 - 13.3 RESPONSE FORMATS 38
- 14 SYSTEM PARAMETERS 39**
 - 14.1 SYSTEM PARAMETER SUMMARY 39
 - 14.2 CHANGING SYSTEM PARAMETERS 39
 - 14.3 SYSTEM PARAMETER DETAILS 40
- 15 SPECIAL FEATURES 44**
 - 15.1 SLEEP MODES 44
 - 15.2 FEATURE REQUESTS..... 44

LIST OF FIGURES

Figure 3-1: SkyeTek Part Number Format	11
Figure 4-1: SM-GM-AC (with all connectors).....	13
Figure 4-2: SkyeModule Gemini Block Diagram.....	13
Figure 5-1: SM-GM Mechanical Drawing.....	15
Figure 6-1: Host Interface Connector Pin Numbering	17
Figure 6-2: External Antenna Pin Numbering.....	18
Figure 9-1: Tag Command Execution Time Measurement.....	23
Figure 9-2: Range Specifications	24
Figure 11-1: USB Connection Diagram.....	28
Figure 11-2: TTL Serial Connection Diagram	29
Figure 11-3: TTL Serial Timing Diagram.....	30
Figure 11-4: SPI Connection Diagram	31
Figure 11-5: SPI Request Setup and Sample Timing	32
Figure 11-6: SPI Request Timing.....	32
Figure 11-7: SPI Response Timing.....	33
Figure 11-8: I ² C Connection Diagram	34
Figure 11-9: I ² C Timing Diagram.....	36

LIST OF TABLES

Table 1-1: Revision History	9
Table 3-1: Gemini Standard Part Numbers.....	11
Table 3-2: Part Number Details.....	11
Table 6-1: SkyeModule Gemini Connector Specification	16
Table 6-2: SkyeModule Gemini Pin Descriptions	17
Table 6-3: External Antenna Pin Descriptions.....	18
Table 7-1: Environmental Ratings/Operating Conditions	20
Table 8-1: SkyeModule Gemini Electrical Specifications.....	21
Table 8-2: Absolute Maximum Ratings.....	22
Table 9-1: Timing Specifications	23
Table 13-1: Request Format (bytes), ASCII Mode	38
Table 13-2: Request Format (bytes), Binary Mode.....	38
Table 13-3: Response Format (bytes), Binary Mode	39
Table 14-1: SkyeModule Gemini System Parameters	40

1 Introduction

1.1 Getting Started

Operating your SkyeModule Gemini begins with finding a method to connect to a host. The module itself does not operate without direction (commands) from a host. The host can be in the form of a PC or, more typically, an embedded microcontroller. This document explains the physical and electrical characteristics of the module, so you can understand how to integrate the Gemini into a finished product.

For **initial demonstration** of the module, **SkyeWare v4 software** is available on the media that came with the developer/evaluation kit or available for download at support.skyetek.com. Open this software on your windows PC and it will be recognized when you connect through USB or RS232 (with developer kit interface board). The software demonstrates features like selecting tags, reading and writing. It also has a powerful command builder that lets you format, send and receive any command to and from the reader. More about SkyeWare can be found in the SkyeWare User Guide. See the Additional Reading section below.

The **next step** after demonstrating the module's functionality is **developing your own communication with the module**. This can be achieved with simple code on a microcontroller or using the SkyeTek API on a PC. Once connected to a host through one of the four host interfaces, the reader to host communication is formatted with a full featured protocol called SkyeTek Protocol v3. In order to make learning commands and formatting easy, we have developed a series of application notes with examples to get you started. The application notes start with basic tag and reader commands and become very detailed for tags with special features. Read more about the protocol and commands in section 13, Communicating with the Module and then move on to the Additional Reading in section 1.3.

1.2 Why a Gemini Module?

Many customers may wonder, "What value does a module add over an RFID transceiver chip?"

RFID transceiver chips may seem simple, but they actually require significant engineering time and capital investment to integrate. Transceiver chips contain up to 50 registers for configuration and functionality. In addition, communicating over air protocols such as ISO14443 is complex, described in nearly 150 pages of cryptic procedures. For example, just selecting a tag requires a minimum of 6 and up to 100 over air interactions with multiple tags present. **Our modules mask the complexities of RFID from the user and pack functionality into just a few commands.**

Our core set of commands allow the user to read and write to tags with a single command, regardless of the tag type. The Gemini handles complex cryptography, which many modules lack, to easily add more security for access control or payment systems. The module is also field upgradeable, so you can use the latest security algorithms and tag features as they are released. Power regulation and filtering for the radio are handled in the Gemini, so you can supply voltage directly from an unregulated source like a battery. Finally, the Gemini will be modularly approved by the FCC and CE, so you can bypass expensive radio testing at a certified test lab and avoid potential schedule delays due to failures.

Using a Gemini module will greatly reduce time to market and upfront development costs.

Allow us to take the burden of developing an RF system so you can focus your energy on your core products.

1.3 Additional Reading

[Gemini Tag Support Matrix](#) – List of supported tags and commands supported with those tags

[Gemini Basic Tag Commands](#) – Application note with descriptions and examples of the basic tag commands: select tag, read tag, and write tag

[SkyeTek Protocol v3 Reader Commands](#) – Application note with descriptions and examples of the reader commands: read/write system, read/write default system, load defaults, and reset

[Keyboard Wedge Operating Mode](#) - This application note describes the Gemini functionality in keyboard wedge mode and also how to enter and exit this mode. Keyboard wedge mode can be very handy when replacing a barcode scanner or when minimal software integration is desired.

[Using MIFARE Classic](#) – Application note with information on the tag and memory structure as well as the protocol commands to support special features of this tag like crypto authentication.

[Using MIFARE Ultralight C](#) – Application note with information on the tag and memory structure as well as the protocol commands to support special features of this tag like authentication and locking.

[Using MIFARE Plus](#) – Application note with information on the tag's memory structure and security levels. It also includes examples of protocol commands to support the special features of this tag like initializing security and Crypto1/AES authentication and MACing.

[Kovio NFC Barcode and 2K](#) – Application note with information on the tag and memory structure as well as the protocol commands to support special features of these tags like locking.

[SkyeTek Protocol v3 Guide](#) – A quick protocol reference for command structure if you already know the command you want to use. This is also a good reference for error codes and tag type codes.

1.4 Revision History

Revision	Author	Change
040913	Brad Alcorn	Initial draft.
111313	Brad Alcorn	Updates for v3.0 hardware and firmware version 0101053.
013114	Brad Alcorn	Minor update to part numbering.
051214	Brad Alcorn	Updates for FCC certification.
061914	Brad Alcorn	Fix to the Reader ID system parameter description and a fix to the description of the I2C host interface functionality.
06092017	Eric S. Harden	Add EU Declaration of Conformance, updated JADAK info
10062017	Eric S. Harden	Added ISED Certification Number and Modular approvals

Table 1-1: Revision History

2 Definition of Terms

3DES	Triple Data Encryption Standard
AES	Advanced Encryption Standard
API	Application Programming Interface
DES	Data Encryption Standard
GPIO	General Purpose Input/Output
HID	Human Interface Device
I ² C	Inter-integrated Circuit
LSB	Least Significant Bit
MSB	Most Significant Bit
NC	No Connect
RoHS	Reduction of Hazardous Substances
SPI	Serial Peripheral Interface
SSEL	Slave Select
STP V3	SkyeTek Protocol Version 3
TTL	Transistor-transistor Logic

3 Ordering Information

3.1 Gemini Standard Part Numbers

Part Number	Host Interface	Baud Rate	Description
SM-GM-UB	TTL Serial	38400 Baud	USB connector only.
SM-GM-MH	TTL Serial	38400 Baud	USB and board to board connector populated.
SM-GM-AC	TTL Serial	38400 Baud	All connectors populated. See Figure 4-1.

Table 3-1: Gemini Standard Part Numbers

NOTE – The Gemini will always communicate via USB, when a USB host is connected.

NOTE – See section 6.1 for more information on the Gemini connectors.

3.2 Part Number Details

The Gemini part number is constructed according to the SkyeTek part number specification below:

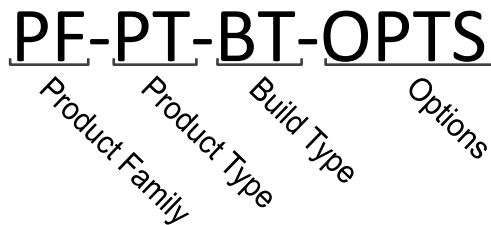

Figure 3-1: SkyeTek Part Number Format

Code	Options	Description
Product Family	SM = SkyeModule	Highest level product family code.
Product Type	GM = Gemini	Specifies the specific part type.
Build Type	UB = USB connector only MH = With USB and MH connectors AC = All connectors	Specifies hardware form factor.
Options	Blank = Standard	This field is left for special customer part numbers or standard variations such I2C for I2C as the default host interface. Consult the SkyeTek sales team for custom orders.

Table 3-2: Part Number Details

4 SkyeModule Gemini Overview

4.1 Description

The SkyeModule™ Gemini marks the next generation of our HF reader modules. The Gemini is a low-cost, and ultra-low power, ISO14443 MIFARE and NFC reader/writer module. A cutting edge ARM Cortex micro-controller and latest HF transceiver technology coupled with the reader's intelligent operating system make this module the most versatile HF RFID module at the bottom tier price point. Manufactured in accordance with ISO 9001 and ISO 13485 processes, quality is our top priority.

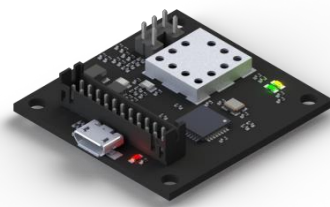

Figure 4-1: SM-GM-AC (with all connectors)

4.2 Block Diagram

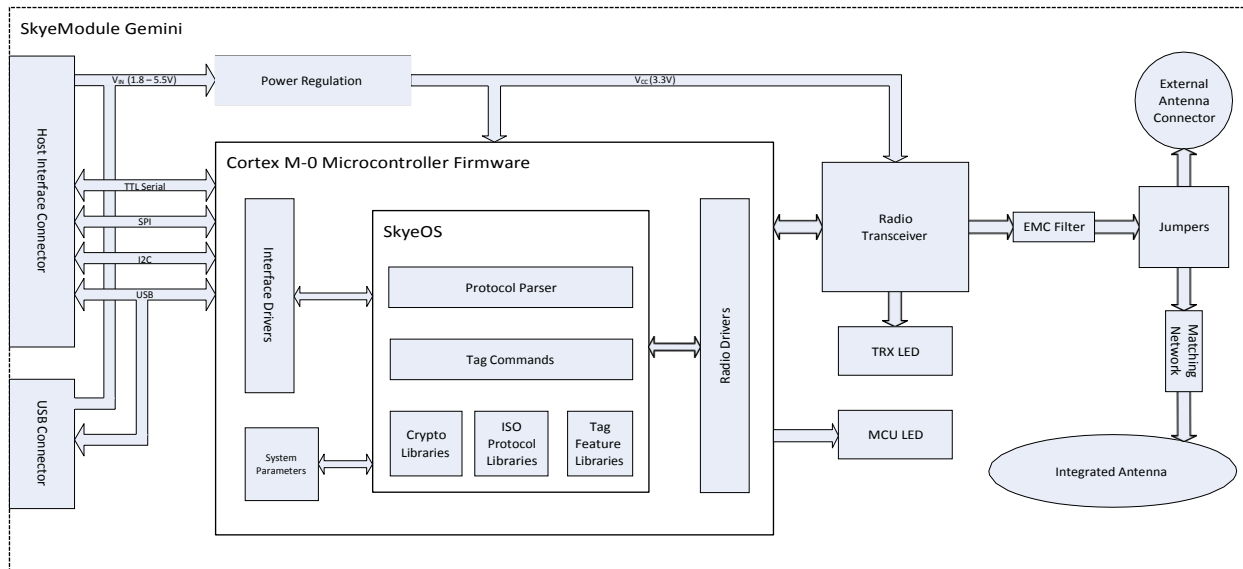

Figure 4-2: SkyeModule Gemini Block Diagram

4.3 Features

- Reads and writes to transponders based on ISO14443A/B
- Reads and writes to other NFC devices based on ISO18092 peer-to-peer (coming soon)
- Emulates NFC tags based on ISO18092 (coming soon)
- 3DES authentication for MIFARE Ultralight C tags (coming soon)
- AES128 authentication and MAC for MIFARE Plus tags
- Crypto1 authentication for MIFARE Classic and Plus tags
- Wide and efficient power supply with input from 2.0 – 5.5V
- Deep sleep mode current down to 10uA
- Easy migration to and from the M2/M4
- Supported host interfaces include USB, TTL level RS232, SPI, I2C
- Integrated internal antenna and options to use external antennas
- Modularly certified (coming soon)

4.4 Applications

- NFC Bluetooth pairing
- NFC Games
- Access control
- Loyalty Card Reader
- Ticketing
- Transportation Fare
- Kiosks
- Product and Consumable Anti-Counterfeiting
- RFID Printers
- ATMs
- Vending Machines
- Debiting Systems

4.5 Agency Approvals

- RoHS 2
- FCC/ISED Modular
- CE Mark
- Japan
- Manufactured in accordance with ISO9001 and ISO13485 processes

5 Mechanical Specifications

Dimensions: 38.2 mm x 40.0 mm = 1528 mm²
 Height without connectors: 4.53 mm

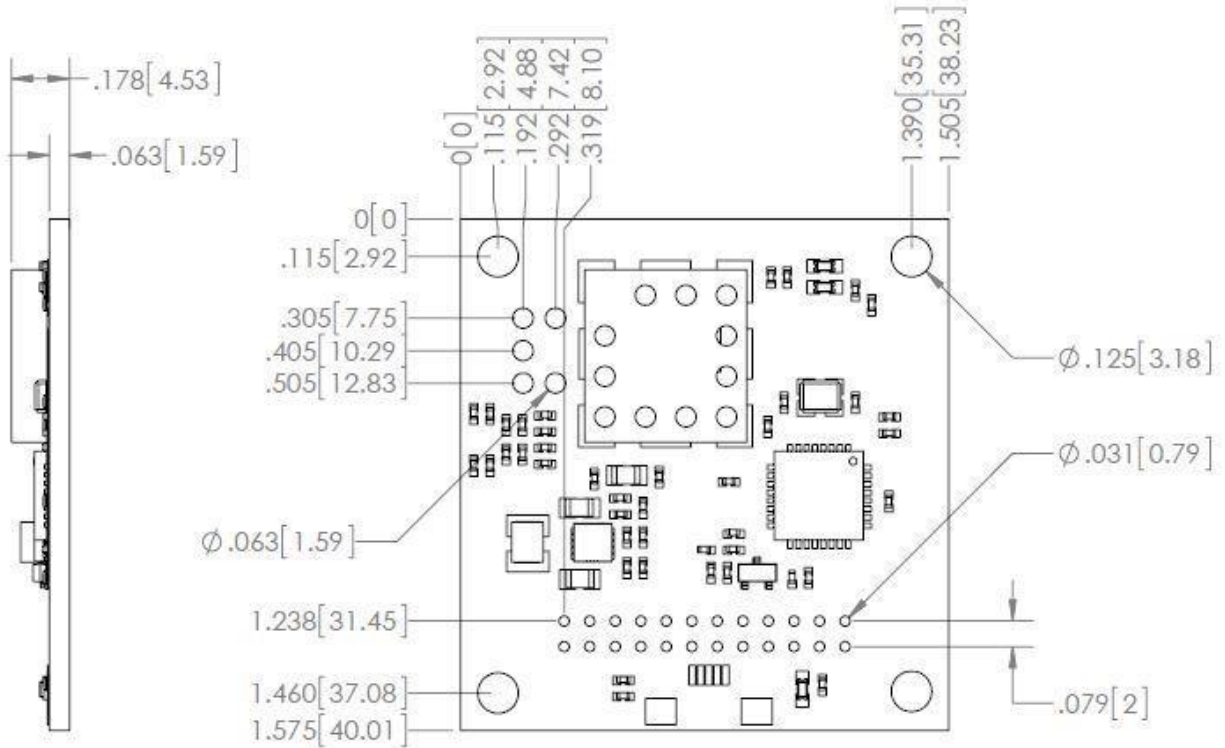

Figure 5-1: SM-GM Mechanical Drawing

6 Pinning Information

6.1 Connector Descriptions

The SM-GM-UB is the standard version of the Gemini module and has only the USB micro connector populated. It also uses the internal antenna by default. Two jumper resistors must be removed from the SM-GM-UB if an external antenna is to be used. In production, customers can connect a host to the module in one of three ways:

- solder cable assemblies directly to the through hole pins of the host interface connector
- solder a custom board to board connector to the host interface 2x12, 2mm through hole footprint
- solder the module directly to a host board with a single 2x12, 2mm header if removal is not desired

For development and prototyping, the Gemini is also offered in the SM-GM-MH form factor with the following connectors populated:

Connector Type	Description	Ref Des	Man.	Man. P/N	Mating Connector
Through hole 2mm, 12x2	Host interface connector	J3	Hirose	DF11-24DP-2DSA(24)	DF11Z-24DS-2V
USB Micro AB Receptacle	USB host interface connector	J4	FCI	10104111-0001LF	USB Micro Plug
Through hole 0.1", 3x2	External antenna connector	J2	Samtec	MTLW-103-05-F-D-190	SLW-103-01-F-D

Table 6-1: SkyeModule Gemini Connector Specification

Custom connectors and antenna configurations can be ordered with a minimum order quantity. Please contact info@jadaktech.com or local reseller to discuss ordering options.

6.2 Host Interface Connector Pin Mapping

The SkyeModule Gemini host connector is a 24-pin through-hole 2mm pitch part. As explained in the previous section, no connector is populated in location J3 in the standard version SM-GM-UB. The pin numbers are located as illustrated in Figure 6-1 below. The pin mappings and descriptions are shown in Table 6-2. Note that all unconnected pins should be left floating.

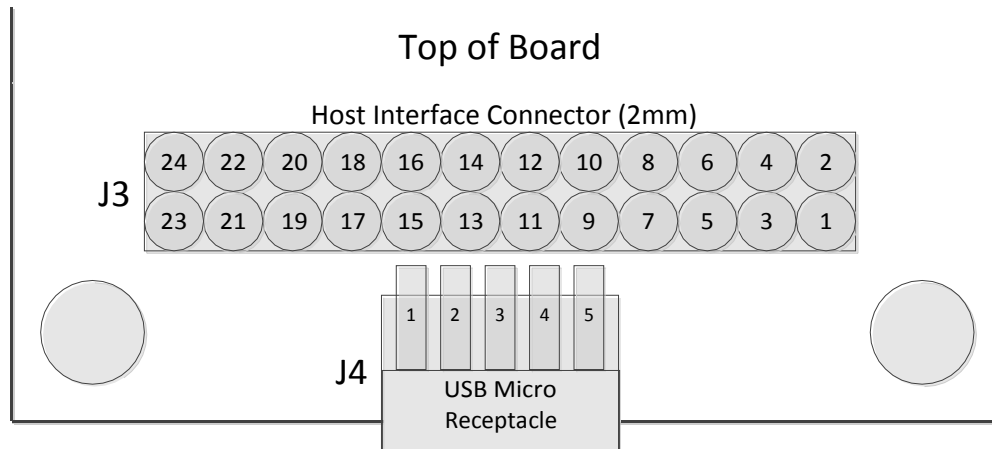

Figure 6-1: Host Interface Connector Pin Numbering

Pin	Name	Description	I/O	Pin	Name	Description	I/O
1	GPIO0	User configurable GPIO	I/O	2	RXD	UART receive	Input
3	GPIO1	User configurable GPIO	I/O	4	TXD	UART transmit	Output
5	GPIO2	User configurable GPIO	I/O	6	NC	Not Connected	N/A
7	GPIO3_DR	User configurable GPIO, Data Ready (see SPI and I2C modes)	I/O	8	N_DEEP_SLEEP	Active low deep sleep. Internally pulled high when unconnected (inactive).	Input
9	VIN	Input power supply pin	Input	10	GND	Ground	Input
11	USB_DP	USB positive	I/O	12	SCL	I ² C Clock	Input
13	USB_DN	USB negative	I/O	14	SDA	I ² C Data	I/O
15	VIN	Input power supply pin	Input	16	GND	Ground	Input
17	3V3_OUT	3.3V supply output pin	Output	18	MISO	SPI master in, slave out	Output
19	N_RESET	Active low reset. Pulled high when unconnected (inactive).	Input	20	MOSI	SPI master out, slave in	Input
21	NC	Not Connected	N/A	22	SCK	SPI clock in	Input
23	NC	Not Connected	N/A	24	SSEL	SPI slave select	Input

Table 6-2: SkyeModule Gemini Pin Descriptions

6.3 External Antenna Connector Pin Mapping

The SkyeModule Gemini can be configured to use either an external or internal antenna. The standard configuration on the SM-GM-UB connects the internal antenna with jumper resistors R20 and R21, which bypass J2. This is the typical configuration for the Gemini. The SM-GM-MH comes with R20 and R21 unpopulated and header pins soldered to J2. This allows the user to select the internal antenna with jumpers across pins 1-4 and 3-5 below or to connect an external antenna with pins 1, 2, and 3 of J2. **More information** on how to connect an antenna can be found in Chapter 12, SkyeModule Gemini Antenna Options.

The antenna connector numbering and description is illustrated below:

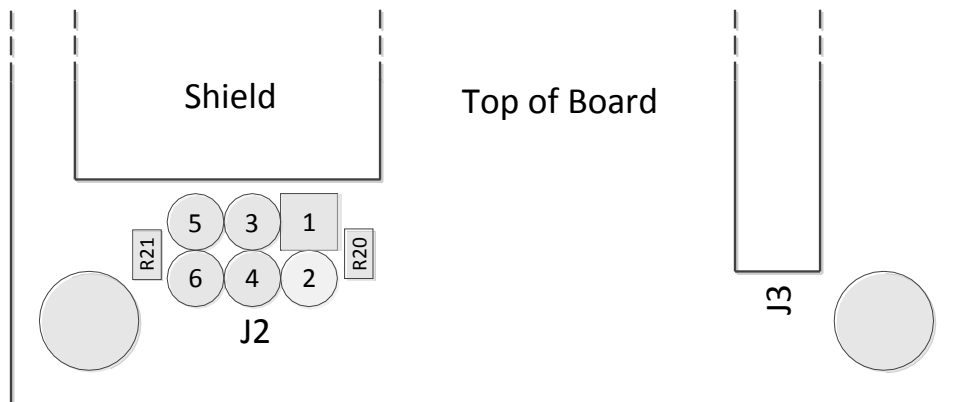

Figure 6-2: External Antenna Pin Numbering

Pin	Name	Description
1	INT_TX2	Internal antenna connection for TX2
2	TX2	Transceiver output 2
3	RX_EXT	External RX for use with external amplifier (contact SkyeTek for more information)
4	GND	Ground for transceiver output
5	INT_TX1	Internal antenna connection for TX1
6	TX1	Transceiver output 1

Table 6-3: External Antenna Pin Descriptions

6.4 Using the GPIO Pins

You can use the User Port Direction and User Port Value system parameters to address the GPIO pins to set the user port direction (input or output) and the user port value (high or low). For more information, see the following:

- “User Port Direction” in section 14.3.9
- “User Port Value” in section 14.3.10

NOTE – GPIO3 is used as a data ready pin when in SPI or I²C mode. GPIO3 cannot be used as GPIO when using these interfaces.

7 Environmental Specifications

7.1 Electrostatic Precautions



CAUTION – Failure to take proper electrostatic precautions may result in damage to or failure of your SkyeModule Gemini.

The SkyeModule Gemini contains static-sensitive parts. Observe the following precautions to prevent damage to these parts.

- Wear a static grounding strap when handling electronic control components.
- Keep all plastic, vinyl, and Styrofoam (except antistatic versions) away from printed circuit boards.
- Do not touch the components or conductors on a printed circuit board with your hands or with conductive devices.

7.2 General Ratings and Operating Conditions

Specification	Rating
Temperature range	Temperature is 25 degrees Celsius unless otherwise noted
Operating	-20 to +70 degrees C
Storage	-40 to +125 degrees C
Humidity	
Operating, continuous storage	10-90 percent (non-condensing)
Transient storage (<24 hours)	5-95 percent maximum (non-condensing)
ESD protection	< 1kV (ESD HBM 15500 Ω , 100pF) —or— 100V (ESD MM 0.75uH, 200pF)

Table 7-1: Environmental Ratings/Operating Conditions

8 Electrical Specifications

This chapter discusses the electrical specifications of the SkyeModule Gemini. Unless otherwise noted, the following assumptions apply to these specifications:

- Temperature is 25 degrees Celsius.
- Frequency is 13.56 MHz.
- Supply voltage (VCC) is 5 V.

8.1 Electrical Characteristics

Specification	Min	Typ	Max	Units/Notes
RF Characteristics				
Frequency ranges (Direct output)		13.56		MHz
Transmission Parameters				
Transmit Power		125		mW
Optimum PA Load Impedance		40 ¹		Ohms
Logic Inputs				
High state input voltage	2.3		5.0	V
Low state input voltage	0		1	V
Input Current (IINH/IINL)			10	nA
Logic Outputs				
Output High Voltage (VOH)	2.8	3.3	3.6	V
Output Low Voltage (VOL)			0.4	V
Output Current (IINH/IINL)			4	mA
Power Supplies				
Voltage Supply	2.0		5.5	V
Idle Current @ 5V Supply		25	30	mA
Continuous Transmit Current @ 5V Supply		58	65	mA
Low Power Software Sleep Mode Current @ 5V Supply		2.5	3	mA
Deep Sleep Mode Current @ 5V Supply		5	10	uA

Table 8-1: SkyeModule Gemini Electrical Specifications

¹ See antenna design application note for more detail on matching the antenna.

8.2 Absolute Maximum Ratings

Specification	Rating
V _{SUPPLY} to GND	7.0 V
Digital I/O voltage to GND	5.5 V

Table 8-2: Absolute Maximum Ratings

9 Performance Specifications

9.1 Timing Specifications

Tag timing is measured from the end of the host request to the beginning of the module response as illustrated in Figure 9-1.

Specification	Min	Typ	Max	Units/Notes
Startup/Wakeup Time				
Cold Startup		35		mS
Low Power Sleep Wakeup		2		mS
Deep Sleep Wakeup		7		mS
Single Select Tag Time (See <i>execute</i> in Figure 9-1)¹				
MIFARE Classic 1K		14.7		mS
MIFARE Ultralight		16.4		mS
KOVIO NFC Barcode 128-bit		3.8		mS
Single Block Read Time¹				
MIFARE Classic 1K		2.3		mS
MIFARE Ultralight		2.4		mS
Single Block Write Time¹				
MIFARE Classic 1K		5.7		mS
MIFARE Ultralight		4.9		mS

Table 9-1: Timing Specifications

¹Tag command times are measured with the system parameter "COMMAND RETRIES" (0x0011) set to 0.

Below is an example of the tag command execution time measurement. The illustration shows the measurement taken from the end of the host command to the beginning of the module response. The host interface shown in the figure is serial.

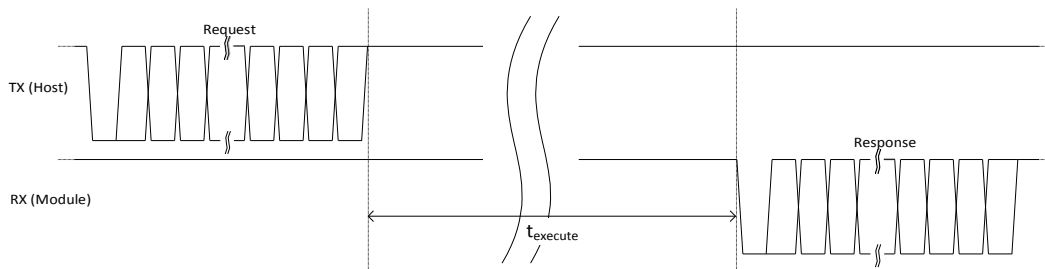

Figure 9-1: Tag Command Execution Time Measurement

9.2 Range Specifications

The range measurements below should be used as a guideline and not a guarantee. Environment can play a major role on tag range performance. Be sure to avoid any conductor in or near the field, as eddy currents can significantly reduce energy transfer between the reader antenna and the tag.

Specification	Min	Typ	Max	Units/Notes
Select Tag Range (Internal Antenna)				
MIFARE Classic 1K Card		4.5		cm
MIFARE Ultralight 52mm Square Label		4.5		cm
MIFARE NTAG203 42mm Circle Label		3.8		cm
KOVIO NFC Barcode 128-bit 42mm Square Label		3.6		cm

Figure 9-2: Range Specifications

WARNING: Read ranges are not guaranteed and are subject to change without warning due to tag silicon or inlay variations.

10 Radio Specifications

10.1 Agency Approvals

As part of a host system, the SkyeModule Gemini will not interfere with the overall system's compliance with agency requirements for emissions and susceptibility, including:

- United States: FCC 15.225 modular approval, FCC ID: WZ4GEMINI003
- Industry Canada ID: 11355A-SMGM
- Europe: EN300-330, EN301-489, EN 61000-4-3
- Japan: AC-17148
- RoHS

This device complies with part 15 of the FCC Rules. Operation is subject to the following two conditions: (1) This device may not cause harmful interference, and (2) this device must accept any interference received, including interference that may cause undesired operation.

NOTE – Changes or modifications not expressly approved by the manufacturer could void the user's authority to operate the equipment

10.2 EU Declaration of Conformity

The SkyeModule Gemini was tested for compliance to the EU RED Directive and our Declaration of Conformity is shown below.

Object of the declaration:	SM-GM-UB, SM-GM-AC, SM-GM-MH
Product Model Numbers:	
Object description:	13.56 MHz Radio Frequency Identification (RFID) Reader / Interrogator Module.
Product Description:	
This declaration of conformity is issued under the sole responsibility of the manufacturer.	
The object of the declaration described above is in conformity with the following relevant European Union harmonization Legislation:	
Directives:	
Identifier	Date
2014/53/EU	16 April 2014
2011/65/EU w/ Amendments M1-M30	19 April 2016

The object described above conforms to the requirements of EU directives through full compliance with the following standards:

European Standards

Standard	Amendments
ETSI EN 300 330 V2.1.1 (2017-02)	None
ETSI EN 301 489-3 V2.1.0 (2016-09)	Draft
CENELEC EN 50581:2012	None

10.3 Host Device Labeling for FCC

If the RFID reader is not visible when installed in the host device, the host device must include one of the following exterior labels:

- Contains Transmitter Module FCC ID: WZ4GEMINI003
- Contains FCC ID: WZ4GEMINI003

10.4 Frequency Band

The Gemini operates in the 13.56MHz (+/- 7KHz) ISM unlicensed band and is suitable for worldwide use. The frequency is not adjustable.

10.5 Tag Protocols

The SkyeModule Gemini supports at least the basic tag commands (select, read, and write) for ISO14443 compliant tags. For the most current listing of supported tags and features, see the [SkyeModule Gemini Tag Support List](#).

11 Host Interface Specifications

The SkyeModule Gemini supports the following microcontroller host interfaces for easy integration into existing systems:

- USB (Overrides other interfaces when connected)
- TTL Serial
- SPI
- I²C

The SkyeModule Gemini and the host interface board support TTL Serial and USB communications. The host interface board provides a USB connector and a TTL to RS-232 level converter for the TTL Serial host interface. The Host Interface system parameter determines which host interface is used to communication with the host. Each interface is software selectable and only one host interface is active at a time, however, USB may always be connected and overrides the current interface. The host interface is selected based on the power-up default value and can be changed at run time. The SkyeModule Gemini operates under host control using SkyeTek Protocol v3 sent over one of the host interfaces described in this chapter.

The following sections describe the power and host communication connections for the SkyeModule Gemini. The SkyeTek Protocol and commands are described further in section 13, Communicating with the Module.

11.1 USB 2.0

As a USB device, the host detects the SkyeModule Gemini as an HID device. The SkyeModule Gemini uses a standard HID driver but is not a certified USB device. The SkyeModule Gemini supports both standard and high speed USB hosts and enumerates correctly on both Windows and UNIX platforms. The USB interface is typically only used for demonstration as a USB host controller is not usually available for in embedded systems. To communicate with the reader in USB mode, either SkyeTek demonstration software or the SkyeTek APIs can be used. See the SkyeTek support site for the latest software and API downloads at support.skyetek.com.

Figure 11-1 shows an example of a circuit to permit USB communications without using the host interface board.

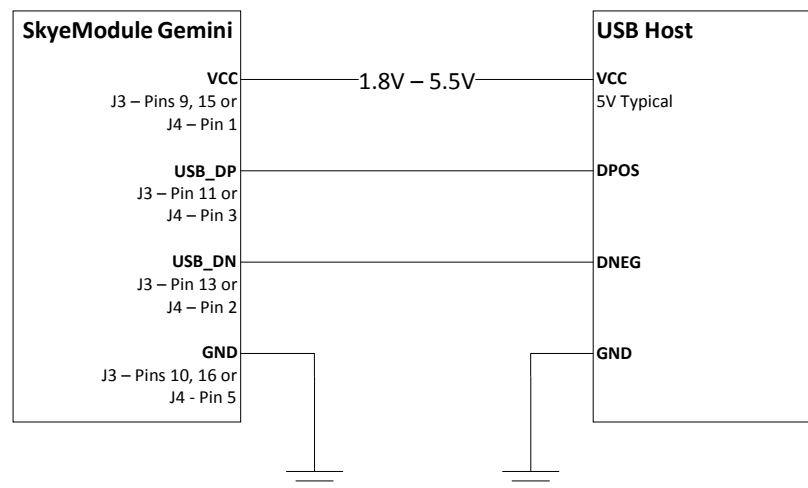

Figure 11-1: USB Connection Diagram

NOTE – If powered by USB, the USB host must be capable of supplying the USB standard high power device, 500mA at 5V.

11.2 TTL Serial

A two-wire serial connection (no handshaking) is provided on the TXD and RXD lines where TXD and RXD are from the module's point of view. Data exchange between the host and the SkyeModule Gemini occurs according to SkyeTek Protocol v3 (ASCII or Binary mode). See more about the protocol in section 13, Communicating with the Module.

Serial communication is the most common and robust host interface for this module in an embedded system. Because the interface is asynchronous, the module responds immediately upon command completion instead of waiting for a host clock as in SPI or I²C.

Figure 11-2 shows a sample circuit that lets you connect the SkyeModule Gemini without the host interface board. Figure 11-3 shows examples of typical communication on a signal level.

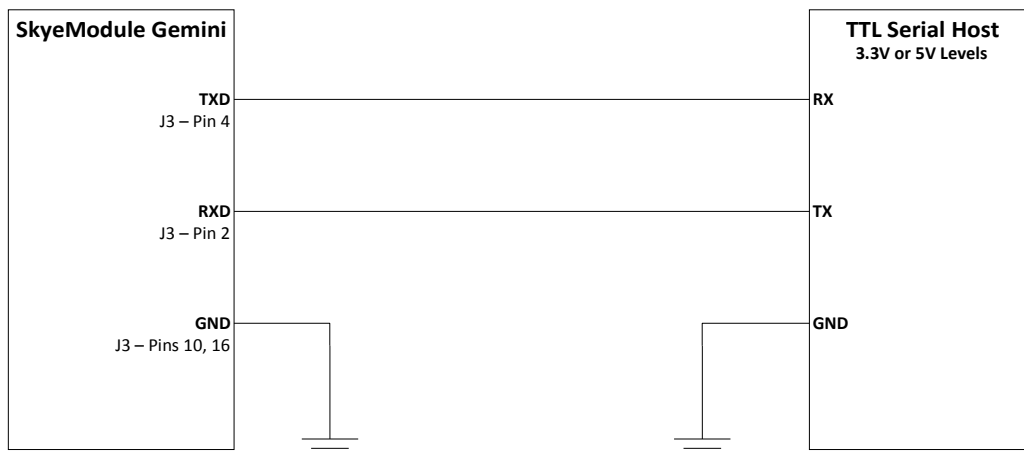

Figure 11-2: TTL Serial Connection Diagram

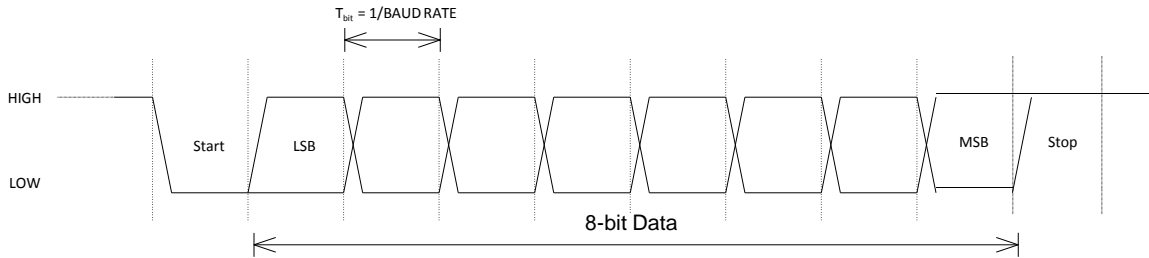

Figure 11-3: TTL Serial Timing Diagram

Notes:

- Baud rate is selectable via the appropriate system parameter. Preprogrammed factory **default baud rate is 38,400 Baud**.
- Bytes are transmitted least-significant bit (LSB) first using the typical serial data format of *Start Bit* followed by *8 data bits* followed by a *Stop Bit*.
- The TTL Serial connection supports bit rates from 9,600 to 115,200 Baud, 8 data bits, no parity, 1 stop bit.
- Host to reader interface shall be TTL level (non-inverted). Both **3.3V and 5V logic levels are allowed**. See logic levels in section 8.1, Electrical Characteristics.

11.3 SPI

The SkyeModule Gemini provides a simple four-wire SPI host interface. There is also an optional data ready signal to indicate that the current command is complete and data is available for the host. Figure 11-4 shows an example of a host interface connection using SPI.

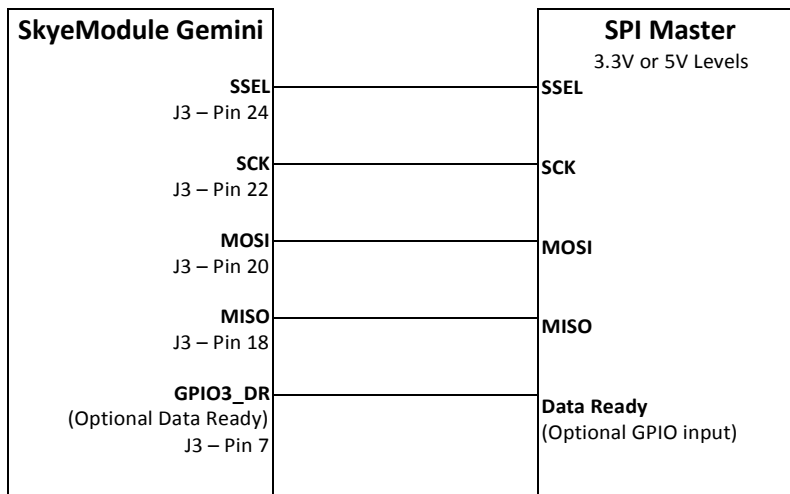

Figure 11-4: SPI Connection Diagram

The protocol for requests to the SkyeModule Gemini is outlined below:

- The data packet exchange between the host (SPI Master) and the Gemini (SPI Slave) uses Skyetek Protocol v3 (Binary Mode only). See more about the protocol in section 13, Communicating with the Module.
- The host must implement SPI master functionality.
- The SCK line is the master clock controlled by the host and should remain low during idle state.
- The slave select line is active low.
- The data is setup on the rising edge of SCK.
- The message data is latched on the falling edge of SCK.
- The MOSI signal line provides the data from the host to the SkyeModule Gemini.
- Supports data rates **up to 4 MBit**
- Both **3.3V and 5V logic levels are allowed**. See logic levels in section 8.1, Electrical Characteristics.

The timing diagram in Figure 11-5 illustrates this behavior.

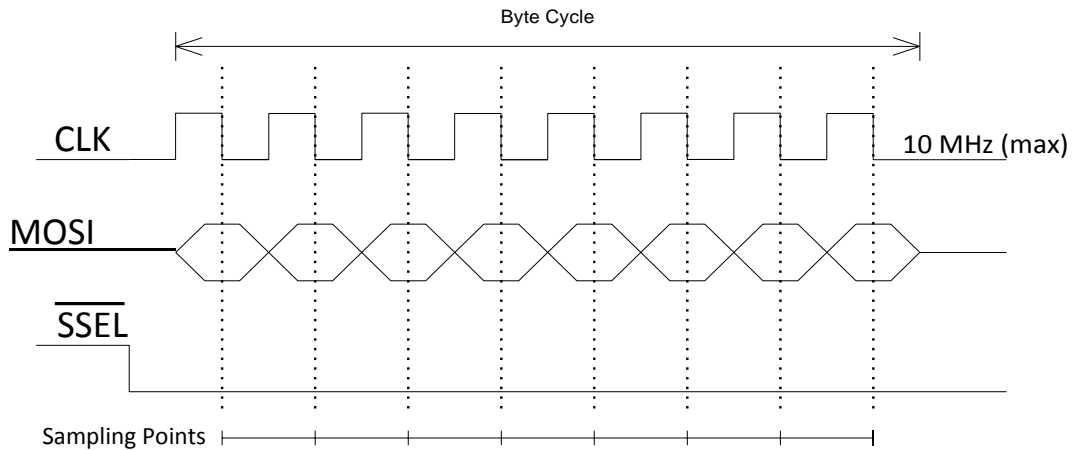

Figure 11-5: SPI Request Setup and Sample Timing

- For the request data on the MOSI line, the host software should keep the SSEL pin at steady state low as shown in Figure 11-6 below.
- The time delay $T_{d,MAX}$ between byte cycles in a request should not exceed 5 ms. After 5 ms the SkyeModule Gemini will timeout, signifying the end of the request.

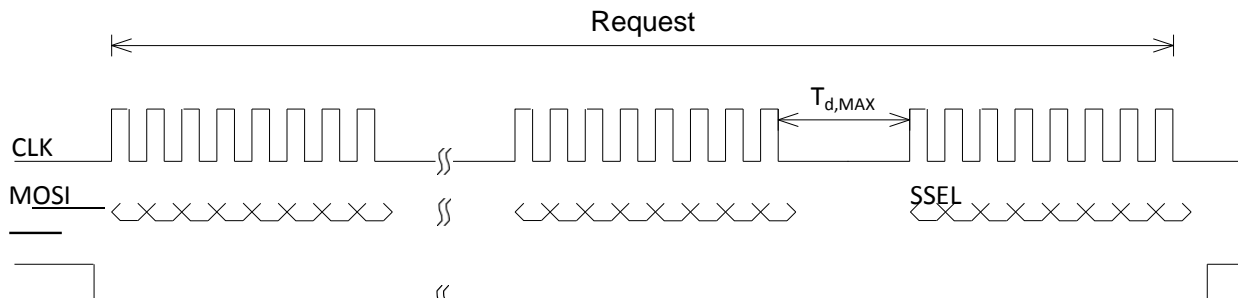

Figure 11-6: SPI Request Timing

The protocol for retrieving the response data is outlined below:

- The SkyeModule Gemini is half duplex so the response data must be retrieved after the request has been sent.
- The GPIO3_DR (data ready) signal will transition high when data is available for the host.
- If data ready is not implemented on the host, the host can poll the module starting 1ms after the command send is complete. The module will respond with 0x00 when no data is present, and 0x02 (start of frame) when data is available.
- Response data will be thrown away if not read within 10 seconds of becoming available.
- The MISO signal provides the response data from SkyeModule Gemini to the host.
- To retrieve data on the MISO line, the SSEL (Slave Select) signal must be low when the clock is sent for an entire byte. Between bytes, SSEL can either stay low or transition high again as long as it transitions low before the first clock of the next byte.
- The host can use the data length field (response bytes 2 and 3) in order to determine how many bytes to read from the module as these first bytes will always be present immediately following a start of frame (0x02).

Figure 11-7 below shows the timing required to retrieve data on the MISO line.

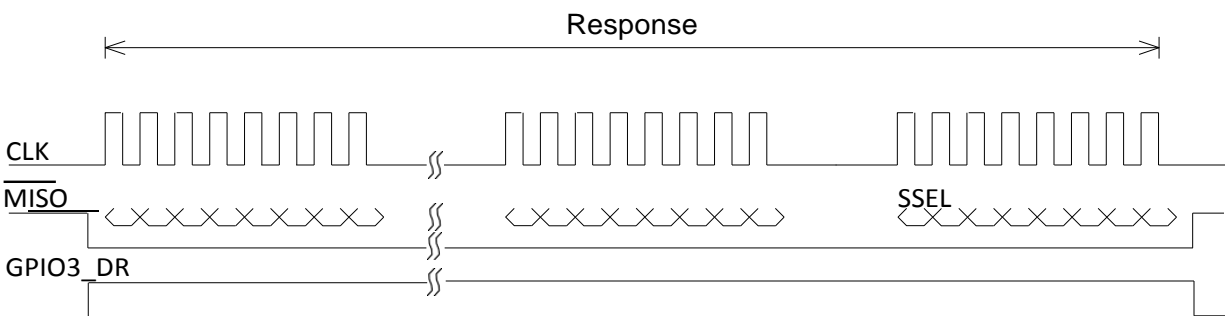

Figure 11-7: SPI Response Timing

NOTE – Not reading the entire response before sending another command can cause undesired behavior. Always make sure to read the entire response when using the SPI interface.

11.4 I²C

The SkyeModule Gemini supports can act as an I²C slave device. External pull up resistors are required on the SDA and SCL lines as shown in Figure 11-8: I²C Connection Diagram. There is also an optional data ready signal to indicate that the current command is complete and data is available for the host.

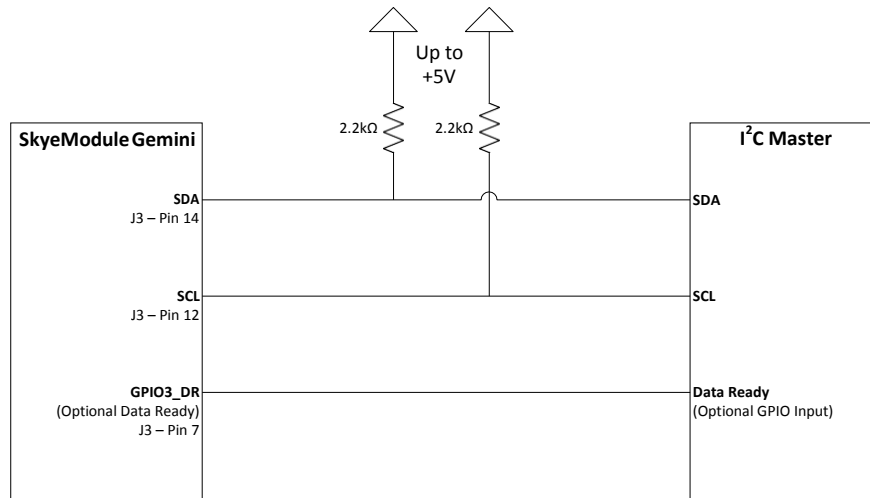

Figure 11-8: I²C Connection Diagram

The protocol for communicating via I²C is outlined below:

- The I²C interface uses a standard two-wire connection in which SCL is the master clock and SDA is a bidirectional serial data line.
- The data packet exchange between the host (I²C Master) and the Gemini (I²C Slave) uses SkyeTek Protocol v3 (Binary Mode only). See more about the protocol in section 13, Communicating with the Module.
- I²C fast mode plus (**1MHz**), I²C fast mode (**400 kHz**), and **100kHz** data rates are all supported.
- The data is sent and received MSB first.
- Up to 5V logic levels are allowed. See logic levels in section 8.1, Electrical Characteristics.
- The device uses a 7-bit address
- The default **address = 0x7F**, but the address can be changed with the Reader ID system parameter. See more about this system parameter in section 14.3.5, Reader ID.

The communication scheme from host to module is as follows:

- Initiate a start condition (SDA transitions low while SCL is high).
- Send the nine bits of the initial start packet as follows:
 - Send the 7-bit address.
 - Send a write bit as the eighth bit (0 for writing from the host to the slave).
 - Send the ninth bit as the "acknowledge" bit (ACK)
 - If the reader recognizes the address, it pulls SDA low to acknowledge
- Use the bus to clock each byte of the SkyeTek protocol request.
- After sending the entire request, initiate a stop condition. (SCL transitions high, and then SDA transitions high while SCL is high)

Wait for command to complete:

- The GPIO3_DR (data ready) signal will transition high when data is available for the host to read.
- If data ready is not implemented on the host, the module uses clock stretching until data becomes available.

Communication scheme from module to host is as follows:

- Initiate a start condition. (SDA transitions low, and then SCL transitions low.)
- Send the nine bits of the initial start packet as follows:
 - Send the 7-bit address.
 - Send a read bit as the eighth bit (1 for reading from the slave to the host).
 - Send the ninth bit as the "acknowledge" bit (ACK)
 - If the reader recognizes the address, it pulls SDA low to acknowledge
 - If the address isn't recognized or the module is busy the SDA bit will remain high during the ACK bit.
- Clock each byte of the SkyeTek protocol response from the module.
- After receiving the response, is received, initiate a stop condition. (SDA transitions high while SCL is high.)
- SDA must transition while the clock is low and remain stable while the clock is high.
- Response data will be thrown away if not read within 10 seconds of becoming available.

Recommended response handler method #1 (clock stretching):

- Wait until the module is no longer stretching the clock
- Read two bytes which contain the message length
- Read the remaining message length

Recommended response handler method #2 (using data ready signal):

- Poll on the data ready signal until it transitions high, indicating that data is present
- Read three bytes, the last two contain the message length
- Read the remaining message length

A timing diagram illustrating the I²C data transfer is shown in the figure below:

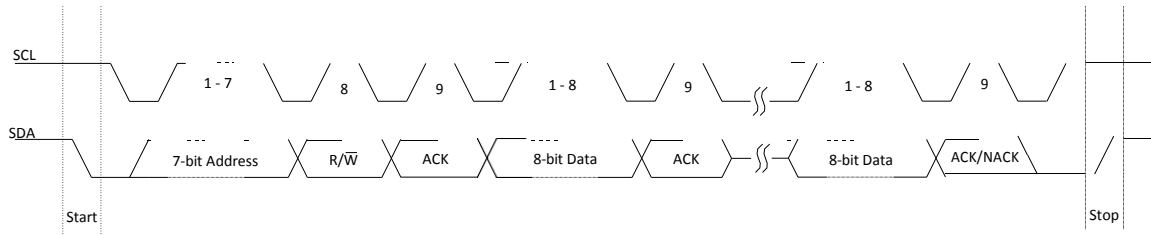

Figure 11-9: I²C Timing Diagram

NOTE – Not reading the entire response before sending another command can cause undesired behavior. Always make sure to read the entire response when using the I²C interface.

12 SkyeModule Gemini Antenna Options

The SkyeModule Gemini is designed to use on-board antenna, but can easily be modified to use an off-the-shelf 13.56MHz external antenna or a custom designed external antenna. The SkyeModule Gemini comes standard (version SM-GM-UB) with resistors R20 and R21 populated to connect the internal antenna. The Gemini can be special ordered without these parts or they can be removed with soldering tools. See section 6.3, External Antenna Connector Pin Mapping for more information.

Internal Antenna - The SkyeModule Gemini comes standard (version SM-GM-UB) with the internal antenna connected. The internal antenna is a PCB trace antenna on the bottom side of the circuit board. This is the most common configuration for the module.

SkyeTek External Antenna - Our designed external antennas can be connected to the Gemini module via three connections (TX1, TX2, and GND). This is typically done with a three wire cable assembly that is soldered to both boards or with any three pin 0.1" through hole connectors. The antenna manufacturing files are freely available on the SkyeTek support site at support.skyetek.com if you'd like to have them built yourself. They can also be purchased through JADAK or a certified reseller.

Custom External Antenna - If a custom size or form factor antenna is required, the [Gemini External Antenna Design Application Note](#) can assist with design. SkyeTek also offers professional services for custom antenna design. Contact info@jadaktech.com for more information.

NOTE – Read range depends on antenna choice and operating environment. Range can vary widely, depending on your choice of tag inlay and antenna gain. See section 9.2, Range Specifications for expected range performance with different antennas.

13 Communicating with the Module

13.1 Host Communication (SkyeTek Protocol v3)

The SkyeModule Gemini operates under control of a host according to SkyeTek Protocol v3. The basic command and response formats are illustrated for your reference in the following two sections 13.2 and 13.3. The best way to get started creating and understanding commands is to follow the application notes below while using the Protocol Builder in SkyeWare v4:

- [Gemini Basic Tag Commands](#) – Guides you through the select tag, read tag and write tag commands.
- [SkyeTek Protocol v3 Reader Commands](#) – Explains how to read and write system parameters.

For more feature specific commands, use the tag specific application notes listed in the Additional Reading section 1.3.

For a quick reference on the protocol if you already know the command you want to use, see the [SkyeTek Protocol v3 Reference Guide](#). This provides detailed information on each command structure, error codes, and tags types; it details every command available for every module.

13.2 Request Formats

Flags	Cmd.	Tag Type	TID Len.	TID	Addr.	# of Blks.	Data Len.	Data	CRC
4	4	4	4	32 (max)	4	4	4	2K	4

Table 13-1: Request Format (bytes), ASCII Mode

Msg Len	Flags	Cmd.	Tag Type	TID Len	TID	Addr	# of Blks	Data Len.	Data	CRC
2	2	2	2	1	32 (max)	2	2	2	1K	2

Table 13-2: Request Format (bytes), Binary Mode

	Required Fields (must be present at all times)
	Optional fields (depending on the command and flags)
	Required fields, depending on the command

13.3 Response Formats

Message Length	Response Code	Tag Type	Data Length	Response Data	CRC
2	2	2	2	1K	2

Table 13-3: Response Format (bytes), Binary Mode

	Required Fields (must be present at all times)
	Optional fields (depending on the command and flags)
	Required fields, depending on the command

14 System Parameters

14.1 System Parameter Summary

System parameters let you configure reader settings to customize the reader for your environment. You can temporarily alter parameters in memory or change the default values stored on the SkyeModule Gemini's non-volatile memory. The following table summarizes the parameters. (See System Parameter Detail in section 14.3 for detailed information about each parameter)

Parameter Name	Address (hex)	Num. Blocks (hex)	Read/Write	Default Value
Serial Number	0x0000	0x0004	R	0x00000000
Firmware Version	0x0001	0x0004	R	0XXXXXXXX (depending on release)
Hardware Version	0x0002	0x0004	R	0XXXXXXXX (depending on release)
Product Code	0x0003	0x0002	R	0x0010
Reader ID	0x0004	0x0004	R/W	0xFFFFFFFF
Reader Name	0x0005	0x0032	R/W	SkyeModule Gemini (in ASCII Format)
Host Interface Type	0x0006	0x0001	R/W	0x01 (TTL)
Interface Baud Rate	0x0007	0x0001	R/W	0x02 (38400)
User Port Direction	0x0008	0x0001	R/W	0x00
User Port Value	0x0009	0x0001	R/W	0x0F
Operating Mode	0x000C	0x0001	W	N/A
Tag Command Retries	0x0011	0x0001	R/W	0x03

Table 14-1: SkyeModule Gemini System Parameters

14.2 Changing System Parameters



CAUTION – Changing system parameter values – especially the default values – can render your SkyeModule Gemini non-operational in your environment. Research, record, and test all planned changes to make sure they are compatible with your system.

You can read or write system parameters via the following commands:

- Read System Parameter – Reads the current value of the system parameter at the memory address specified.
- Write System Parameter – Writes a new value to the system parameter at the memory address specified.

- Store Default System Parameter – Writes a new system parameter value to the non-volatile memory. This saves the setting even after a power cycle or reset.
- Retrieve Default System Parameter – Reads the system parameter value at the address specified out of non-volatile memory.

See System Parameter Detail in section 14.3 for detailed information about individual parameters.

For full examples of how to use these commands, see the system parameter examples found in the [Using SkyeProtocol V3 Reader Commands](#) application note.



CAUTION – Resetting (cycling power) on your SkyeModule Gemini causes all system parameters to revert to their default values. Any changes made to system parameters in memory are lost at reset unless you write them to the non-volatile memory as the new default values. Any changes to the default values do not take effect until the reader is reset.

14.3 System Parameter Details

This section describes the SkyeModule Gemini system parameters.

14.3.1 Serial Number

- Returns the serial number of the reader
- Parameter address: 0x0000
- Length (bytes): 4
- Default value: 0x00000000
- Read-only

14.3.2 Firmware Version

- Returns the firmware version currently loaded on the reader. (Refer to the [SkyeModule Gemini Release Notes](#) for more information about the specific firmware release.)
- Refer to the [SkyeWare User Guide](#) for information about updating firmware.
- Parameter address: 0x0001
- Length (bytes): 4
- Default value: 0XXXXXXXX (depending on release)
- The firmware version uses this format:
 - Major revision (1 Byte)
 - Minor revision (1 Byte)
 - Current build number (2 bytes)
- Read-only

14.3.3 Hardware Version

- Returns the current hardware version of the reader
- Parameter address: 0x0002
- Length (bytes): 4
- Default value: 0XXXXXXXX (depending on release)
- The hardware version uses the following format:
 - Major revision (1 Byte)
 - Minor revision (1 Byte)
 - Current build number (2 bytes)
- Read-only

14.3.4 Product Code

- Returns the SkyeTek product code identifier. (Each product has a unique productcode.)
- Parameter address: 0x0003
- Length (bytes): 2
- Default value: 0x0010
- Read-only

14.3.5 Reader ID

- Previously used for a deprecated SkyeTek protocol feature, it is now used as the I²C address of the reader in I²C mode. The first byte of the reader ID acts as the 7-bit I²C address.
- Example: A value of 0x1B000000 would indicate an I²C address of 0x1B
- Parameter address: 0x0004
- Length (bytes): 4
- Default value: 0xFFFFFFFF
- Read/write

14.3.6 Reader Name

- Identifies a reader with a 32-byte user-defined name.
- Parameter address: 0x0005
- Length (bytes): 32 (20 hex)
- Default value is "SkyeModule Gemini" (in hex)
- Read/write

14.3.7 Host Interface Type

- Identifier for the type of host interface being used.
- Parameter address: 0x0006
- Length (bytes): 1

- Default value: 0x01 (TTL Serial)
- Valid host interface values are:
 - 0x01 – TTL Serial
 - 0x03 – SPI
 - 0x05 – I²C
 - 0x06 – USB
 - Any other values are invalid and are ignored.
- Read/write

14.3.8 Interface Baud Rate

- Sets the baud rate of the host interface.
- Works for the TTL Serial host interface only.
- Parameter address: 0x0007
- Length (bytes): 1
- Default value: 0x02 (38,400)
- Valid baud rate values are:
 - 0x01 – 19200
 - 0x02 – 38400
 - 0x03 – 57600
 - 0x04 – 115200
 - 0x05 – 1 MBaud
 - Any other value – 9600
- Read/write

14.3.9 User Port Direction

- Sets the direction of the GPIO pins of the reader.
- Parameter address: 0x0008
- Length (bytes): 1
- Default value: 0x00
- Default value is 0x00 (GPIO pins are outputs).
- A one in the bit position indicates that the corresponding GPIO pin is an input.
- A zero in the bit position indicates that the corresponding GPIO pin is an output.
- Bits correspond to the pins as follows:
 - BIT0 – GPIO 0
 - BIT1 – GPIO 1
 - BIT2 – GPIO 2
 - BIT3 – GPIO 3
 - BIT4 - BIT7 – Reserved
- Read/write

14.3.10 User Port Value

- Sets or reads the value of the GPIO pins of the reader.
- Parameter address: 0x0009
- Length (bytes): 1
- Default value is 0x0F (GPIO pins are logic high).
- A one in the bit position indicates that the corresponding GPIO pin is logic high.
- A zero in the bit position indicates that the corresponding GPIO pin is logic low.
- Bits correspond to the pins as follows:
 - BIT0 – GPIO 0
 - BIT1 – GPIO 1
 - BIT2 – GPIO 2
 - BIT3 – GPIO 3
 - BIT4 - BIT7 – Reserved
- Read/write

14.3.11 Operating Mode

- Can put the reader into sleep mode or into keyboard wedge mode.
- Parameter address: 0x000C
- Length (bytes): 1
- Default value is 0x00 (active).
- Writing a value 0x01 to this system parameter puts the reader in sleep mode.
- Writing a value 0x02 to this system parameter puts the reader into keyboard wedge mode. See the [Keyboard Wedge Operating Mode](#) application note for details.
- Sending a single byte on the interface that put the reader to sleep wakes the reader from sleep mode.
- **NOTE: SOFTWARE SLEEP MODE DOES NOT FUNCTION IN USB COMMUNICATIONS.** This is planned for future firmware releases.
- Write Only

14.3.12 Tag Command Retries

- Sets the number of times a tag command will be retried internally.
- Parameter address: 0x0011
- Length (bytes): 1
- Default value is 0x03
- In very time dependent applications, it is recommended to set this parameter to 0 as this removes much of the variability of response time.
- In most situations, a retry number of 3 is sufficient.
- Read/write
- **WARNING:** Setting this parameter too high can cause very long response times when there is no tag or a failing tag in the field.

15 Special Features

15.1 Sleep Modes

The Gemini has two low power sleep modes: deep sleep (hardware controlled) and software sleep mode. The deep sleep mode has the lowest power consumption but a longer wake time. It can only be set using the N_DEEP_SLEEP pin 8 of the host interface connector. There is an internal pull-up on this pin, so if it is unused it can be left floating. To put the reader into deep sleep, set this pin low. Software sleep mode can be set using the Operating Mode system parameter. See the System Parameters section 14 for details. Current consumption and wake times for both modes can be found in the Electrical Characteristics section 8.1 and Timing Specifications section 9.1, respectively.

NOTE: SOFTWARE SLEEP MODE DOES NOT WORK IN USB COMMUNICATIONS. This is planned for future firmware releases.

15.2 Feature Requests

Request a feature for the Gemini module at info@jadaktech.com.

X-ON Electronics

Largest Supplier of Electrical and Electronic Components

Click to view similar products for [RFID Transponder Tools](#) category:

Click to view products by [Skyetek](#) manufacturer:

Other Similar products are found below :

[SP-MX-08-HF-M2](#) [V700-A43 10M](#) [WF-SM-30](#) [V700-A44 20M](#) [V680-A81](#) [V680-A60 2M](#) [WS02-CFSC1-EV3](#) [V680-A60 5M](#) [V680-HAM91](#) [V680-A60 10M](#) [V700-A46 50M](#) [V680S-HMD66-ETN](#) [MEDP-MF-RFID-R10](#) [ST25-TAG-BAG-U](#) [MIKROE-3644](#) [MIKROE-2395](#) [1482](#) [MIKROE-2462](#) [2800](#) [2802](#) [X-NUCLEO-NFC05A1](#) [359](#) [360](#) [361](#) [362](#) [363](#) [365](#) [3781](#) [789](#) [884](#) [4032](#) [4034](#) [4043](#) [4429](#) [4701](#) [AS3980-QF_DK_ST](#) [AS3930](#) [DEMOSYSTEM](#) [AS3953-DK-TAGS](#) [ATARFID-EK1](#) [ATARFID-EK2](#) [EVB90109](#) [MIKROE-3659](#) [MIKROE-3971](#) [MIKROE-4208](#) [MIKROE-1434](#) [MIKROE-1475](#) [MIKROE-1726](#) [MIKROE-262](#) [MIKROE-4309](#) [13429-6001](#)