



SKYWORKS®

Si590/591

1 ps MAX JITTER CRYSTAL OSCILLATOR (XO) (10 MHz TO 810 MHz)

Features

- Available with any-frequency output frequencies from 10 to 810 MHz
- 3rd generation DSPLL® with superior jitter performance: 1 ps max jitter
- Better frequency stability than SAW-based oscillators
- Internal fundamental mode crystal ensures high reliability
- Available CMOS, LVPECL, LVDS, and CML outputs
- 3.3, 2.5, and 1.8 V supply options
- Industry Standard 5x7 and 3.2x5 mm packages
- Pb-free/RoHS-compliant
- -40 to +85 °C operating temperature range

Applications

- SONET/SDH (OC-3/12/48)
- Networking
- SD/HD SDI/3G SDI video
- Test and measurement
- Storage
- FPGA/ASIC clock generation

Description

The Si590/591 XO utilizes Skyworks Solutions' advanced DSPLL® circuitry to provide a low jitter clock at high frequencies. The Si590/591 supports any frequency from 10 to 810 MHz. Unlike a traditional XO, where a unique crystal is required for each output frequency, the Si590/591 uses one fixed crystal to provide a wide range of output frequencies. This IC based approach allows the crystal resonator to provide exceptional frequency stability and reliability. In addition, DSPLL clock synthesis provides superior supply noise rejection, simplifying the task of generating low jitter clocks in noisy environments typically found in communication systems. The Si590/591 IC based XO is factory configurable for a wide variety of user specifications including frequency, supply voltage, output format, and stability. Specific configurations are factory programmed at time of shipment, thereby eliminating long lead times associated with custom oscillators.

Functional Block Diagram

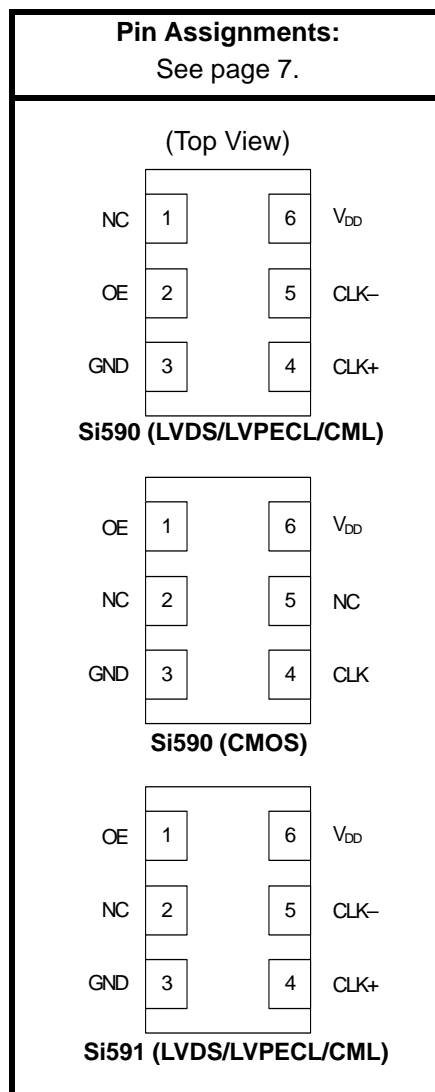
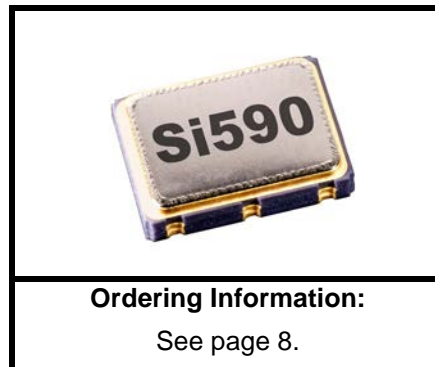
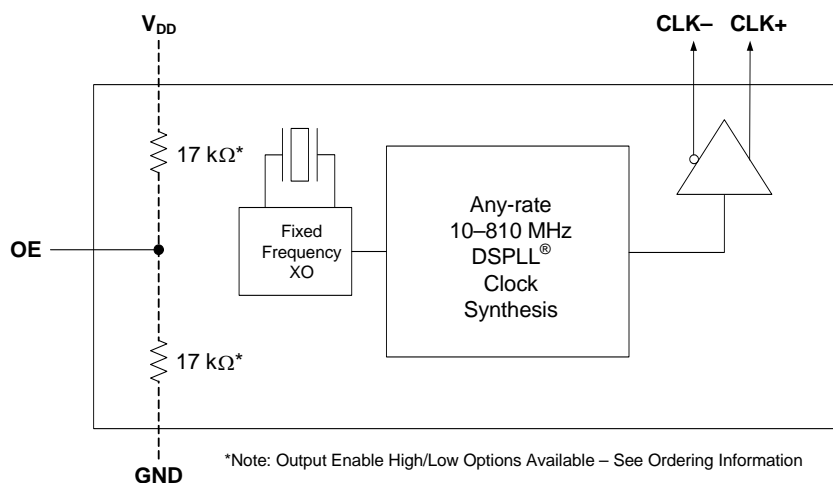

Si590/591

TABLE OF CONTENTS

1. Electrical Specifications	3
2. Pin Descriptions	7
3. Ordering Information	8
4. Package Outline Drawing: 5 x 7 mm, 6-pin	9
5. PCB Land Pattern: 5 x 7 mm, 6-pin	10
6. Package Outline Drawing: 3.2 x 5 mm, 6-pin	11
7. PCB Land Pattern: 3.2 x 5 mm, 6-pin	12
8. Si590/Si591 Top Marking: 5 x 7 mm	13
9. Si590/Si591 Top Marking: 3.2 x 5 mm	14
Revision History	15
Contact Information	16

1. Electrical Specifications

Table 1. Recommended Operating Conditions

Parameter	Symbol	Test Condition	Min	Typ	Max	Units
Supply Voltage ¹	V _{DD}	3.3 V option	2.97	3.3	3.63	V
		2.5 V option	2.25	2.5	2.75	
		1.8 V option	1.71	1.8	1.89	
Supply Current	I _{DD}	Output enabled LVPECL	—	110	125	mA
		CML	—	100	110	
		LVDS	—	90	100	
		CMOS	—	80	90	
		Tristate mode	—	60	75	
Output Enable (OE) ²		V _{IH}	0.75 x V _{DD}	—	—	V
		V _{IL}	—	—	0.5	
Operating Temperature Range	T _A		−40	—	85	°C
Notes:						
1. Selectable parameter specified by part number. See Section 3. "Ordering Information" on page 8 for further details.						
2. OE pin includes an internal 17 kΩ pullup resistor to V _{DD} for output enable active high or a 17 kΩ pull-down resistor to GND for output enable active low. See 3. "Ordering Information" on page 8.						

Table 2. CLK± Output Frequency Characteristics

Parameter	Symbol	Test Condition	Min	Typ	Max	Units
Nominal Frequency ^{1,2}	f _O	LVPECL/LVDS/CML	10	—	810	MHz
		CMOS	10	—	160	
Initial Accuracy	f _i	Measured at +25 °C at time of shipping	—	±1.5	—	ppm
Total Stability		Note 3, second option code "D"	—	—	±20	ppm
		Note 3, second option code "C"	—	—	±30	ppm
		Note 4, second option code "B"	—	—	±50	ppm
		Note 4, second option code "A"	—	—	±100	ppm
Temperature Stability		second option code "D"	—	—	±7	ppm
		second option code "C"	—	—	±20	ppm
		second option code "B"	—	—	±25	ppm
		second option code "A"	—	—	±50	ppm
Powerup Time ⁵	t _{OSC}		—	—	10	ms
Notes:						
1. See Section 3. "Ordering Information" on page 8 for further details.						
2. Specified at time of order by part number.						
3. Includes initial accuracy, temperature, shock, vibration, power supply and load drift, and 10 years aging at 40 °C. See 3. "Ordering Information" on page 8.						
4. Includes initial accuracy, temperature, shock, vibration, power supply and load drift, and 15 years aging at 70 °C. See 3. "Ordering Information" on page 8.						
5. Time from powerup or tristate mode to f _O .						

Si590/591

Table 3. CLK± Output Levels and Symmetry

Parameter	Symbol	Test Condition	Min	Typ	Max	Units
LVPECL Output Option ¹	V _O	mid-level	V _{DD} - 1.42	—	V _{DD} - 1.25	V
	V _{OD}	swing (diff)	1.1	—	1.9	V _{PP}
	V _{SE}	swing (single-ended)	0.55	—	0.95	V _{PP}
LVDS Output Option ²	V _O	mid-level	1.125	1.20	1.275	V
	V _{OD}	swing (diff)	0.5	0.7	0.9	V _{PP}
CML Output Option ²	V _O	2.5/3.3 V option mid-level	—	V _{DD} - 1.30	—	V
		1.8 V option mid-level	—	V _{DD} - 0.36	—	
	V _{OD}	2.5/3.3 V option swing (diff)	1.10	1.50	1.90	V _{PP}
		1.8 V option swing (diff)	0.35	0.425	0.50	
CMOS Output Option ³	V _{OH}		0.8 x V _{DD}	—	V _{DD}	V
	V _{OL}		—	—	0.4	
Rise/Fall time (20/80%)	t _R , t _F	LVPECL/LVDS/CML	—	—	350	ps
		CMOS with C _L = 15 pF	—	2	—	ns
Symmetry (duty cycle)	SYM	LVPECL: V _{DD} - 1.3 V (diff) LVDS: 1.25 V (diff) CMOS: V _{DD} /2	45	—	55	%

Notes:

1. 50 Ω to V_{DD} - 2.0 V.
2. R_{term} = 100 Ω (differential).
3. C_L = 15 pF. Sinking or sourcing 12 mA for V_{DD} = 3.3 V, 6 mA for V_{DD} = 2.5 V, 3 mA for V_{DD} = 1.8 V.

Table 4. CLK± Output Phase Jitter

Parameter	Symbol	Test Condition	Min	Typ	Max	Units
Phase Jitter (RMS) ¹ for 50 MHz ≤ F _{OUT} ≤ 810 MHz (LVPECL/LVDS/CML)	φ _J	12 kHz to 20 MHz	—	0.5	1.0	ps
Phase Jitter (RMS) ¹ (LVPECL/LVDS/CML)	φ _J	12 kHz to 20 MHz, 155.52 MHz output frequency	—	0.4	0.7	ps
Phase Jitter (RMS) ² for 50 MHz ≤ F _{OUT} ≤ 160 MHz (CMOS)	φ _J	12 kHz to 20 MHz	—	0.6	1.0	ps

Notes:

1. Refer to AN256 for further information.
2. Single-ended CMOS output phase jitter measured using 33 Ω series termination into 50 Ω phase noise test equipment. 3.3 V supply voltage option only.

Table 5. CLK± Output Period Jitter

Parameter	Symbol	Test Condition	Min	Typ	Max	Units
Period Jitter*	J _{PER}	RMS	—	—	3	ps
		Peak-to-Peak	—	—	35	

*Note: Any output mode, including CMOS, LVPECL, LVDS, CML. N = 1000 cycles. Refer to AN279 for further information.

Table 6. Environmental Compliance and Package Information

Parameter	Conditions/Test Method
Mechanical Shock	MIL-STD-883, Method 2002
Mechanical Vibration	MIL-STD-883, Method 2007
Solderability	MIL-STD-883, Method 2003
Gross and Fine Leak	MIL-STD-883, Method 1014
Resistance to Solder Heat	MIL-STD-883, Method 2036
Contact Pads	Gold over Nickel

Table 7. Thermal Characteristics(Typical values T_A = 25 °C, V_{DD} = 3.3 V)

Parameter	Symbol	Test Condition	Min	Typ	Max	Unit
5x7mm, Thermal Resistance Junction to Ambient	θ _{JA}	Still Air	—	84.6	—	°C/W
5x7mm, Thermal Resistance Junction to Case	θ _{JC}	Still Air	—	38.8	—	°C/W
3.2x5mm, Thermal Resistance Junction to Ambient	θ _{JA}	Still Air	—	31.1	—	°C/W
3.2x5mm, Thermal Resistance Junction to Case	θ _{JC}	Still Air	—	13.3	—	°C/W
Ambient Temperature	T _A		-40	—	85	°C
Junction Temperature	T _J		—	—	125	°C

Table 8. Absolute Maximum Ratings¹

Parameter	Symbol	Rating	Units
Maximum Operating Temperature	T_{AMAX}	85	°C
Supply Voltage, 1.8 V Option	V_{DD}	-0.5 to +1.9	V
Supply Voltage, 2.5/3.3 V Option	V_{DD}	-0.5 to +3.8	V
Input Voltage (any input pin)	V_I	-0.5 to $V_{DD} + 0.3$	V
Storage Temperature	T_S	-55 to +125	°C
ESD Sensitivity (HBM, per JESD22-A114)	ESD	2500	V
Soldering Temperature (Pb-free profile) ²	T_{PEAK}	260	°C
Soldering Temperature Time @ T_{PEAK} (Pb-free profile) ²	t_p	20–40	seconds

Notes:

1. Stresses beyond those listed in Absolute Maximum Ratings may cause permanent damage to the device. Functional operation or specification compliance is not implied at these conditions. Exposure to maximum rating conditions for extended periods may affect device reliability.
2. The device is compliant with JEDEC J-STD-020C. Refer to Si5xx Packaging FAQ available at https://www.skyworksinc.com/Product_Certificate.aspx for further information, including soldering profiles.

2. Pin Descriptions

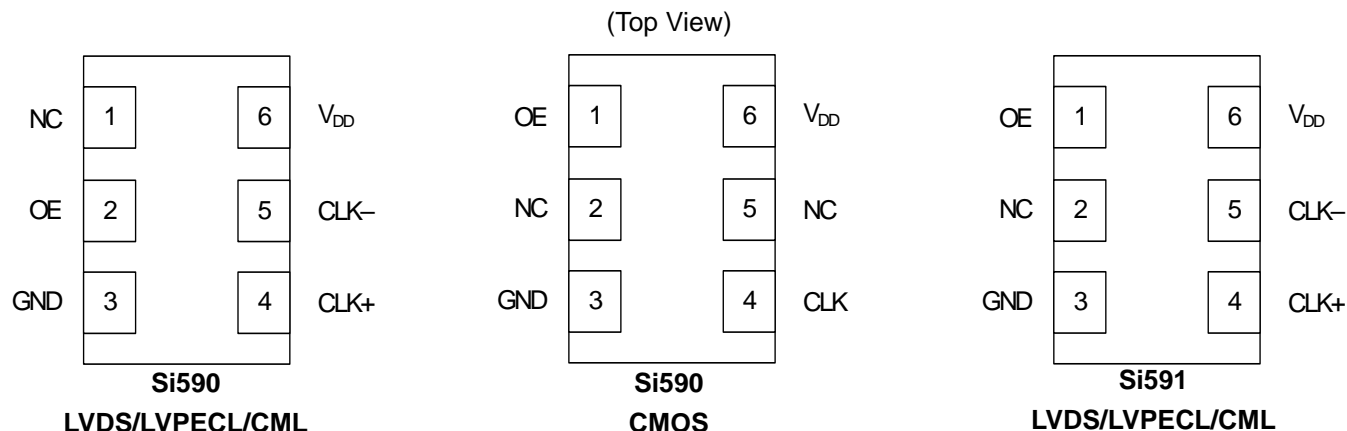

Table 9. Pinout for Si590 Series

Pin	Symbol	LVDS/LVPECL/CML Function	CMOS Function
1	OE*	No connection Make no external connection to this pin	Output enable
2	OE*	Output enable	No connection Make no external connection to this pin
3	GND	Electrical and Case Ground	Electrical and Case Ground
4	CLK+	Oscillator Output	Oscillator Output
5	CLK-	Complementary Output	No connection Make no external connection to this pin
6	V _{DD}	Power Supply Voltage	Power Supply Voltage

***Note:** OE pin includes an internal 17 kΩ pullup resistor to V_{DD} for output enable active high or a 17 kΩ pulldown resistor to GND for output enable active low. See 3. "Ordering Information" on page 8.

Table 10. Pinout for Si591 Series

Pin	Symbol	LVDS/LVPECL/CML Function
1	OE*	Output enable
2	No connection Make no external connection to this pin	No connection Make no external connection to this pin
3	GND	Electrical and Case Ground
4	CLK+	Oscillator Output
5	CLK-	Complementary output
6	V _{DD}	Power Supply Voltage

***Note:** OE pin includes an internal 17 kΩ pullup resistor to V_{DD} for output enable active high or a 17 kΩ pulldown resistor to GND for output enable active low. See 3. "Ordering Information" on page 8.

3. Ordering Information

The Si590/591 XO supports a variety of options including frequency, temperature stability, output format, and V_{DD} . Specific device configurations are programmed into the Si590/591 at time of shipment. Configurations can be specified using the Part Number Configuration chart below. Skyworks Solutions provides a web browser-based part number configuration utility to simplify this process. To access this tool refer to <https://www.skyworksinc.com/en/Products/Timing>. The Si590 and Si591 XO series are supplied in an industry-standard, RoHS compliant, 6-pad, 5 x 7 mm and 3.2 x 5 mm packages. The Si591 Series supports an alternate OE pinout (pin #1) for LVPECL, LVDS, and CML output formats. See Tables 9 and 10 for the pinout differences between the Si590 and Si591 series.

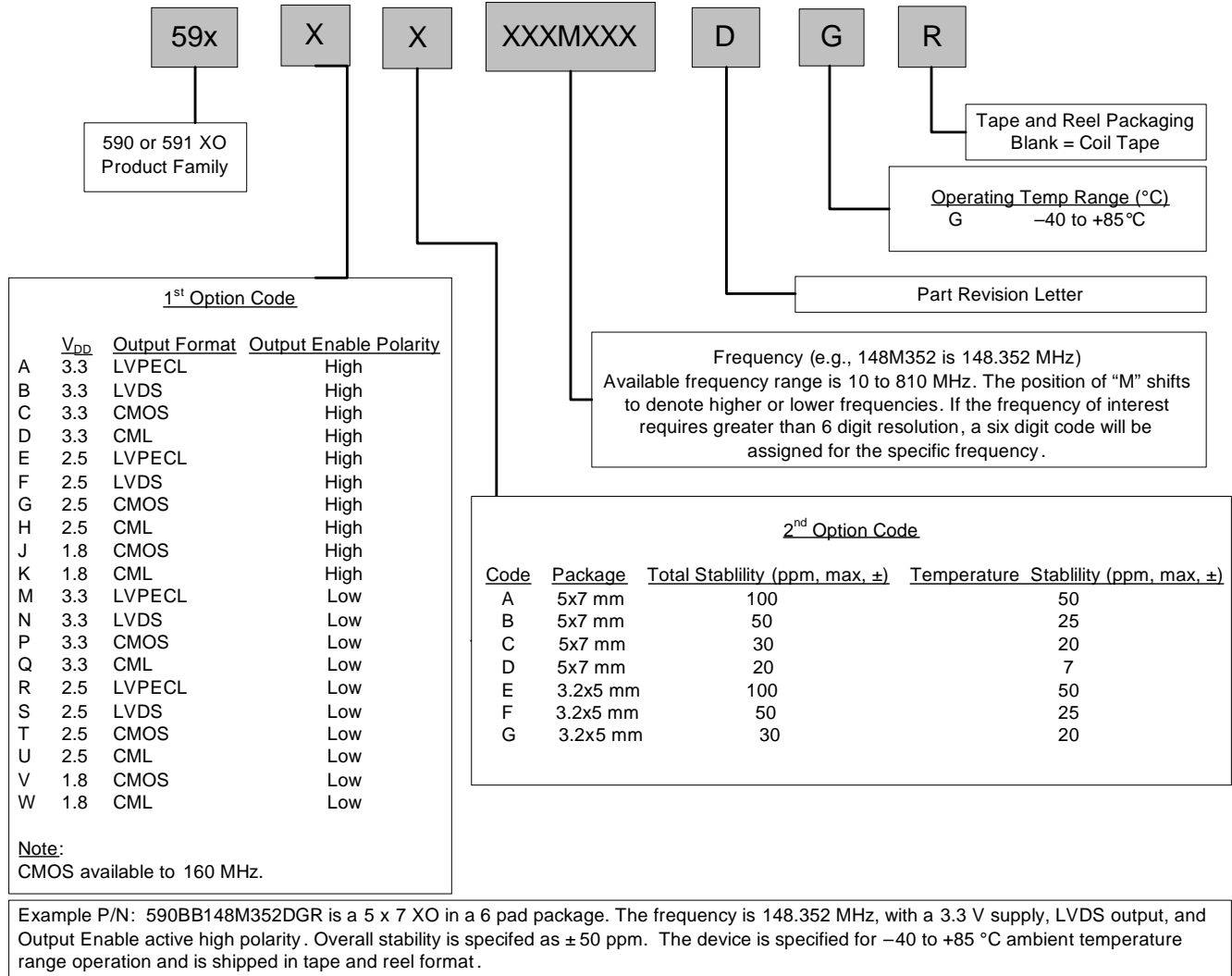

Figure 1. Part Number Convention

4. Package Outline Drawing: 5 x 7 mm, 6-pin

Figure 2 illustrates the package details for the 5 x 7 mm Si590/591. Table 11 lists the values for the dimensions shown in the illustration.

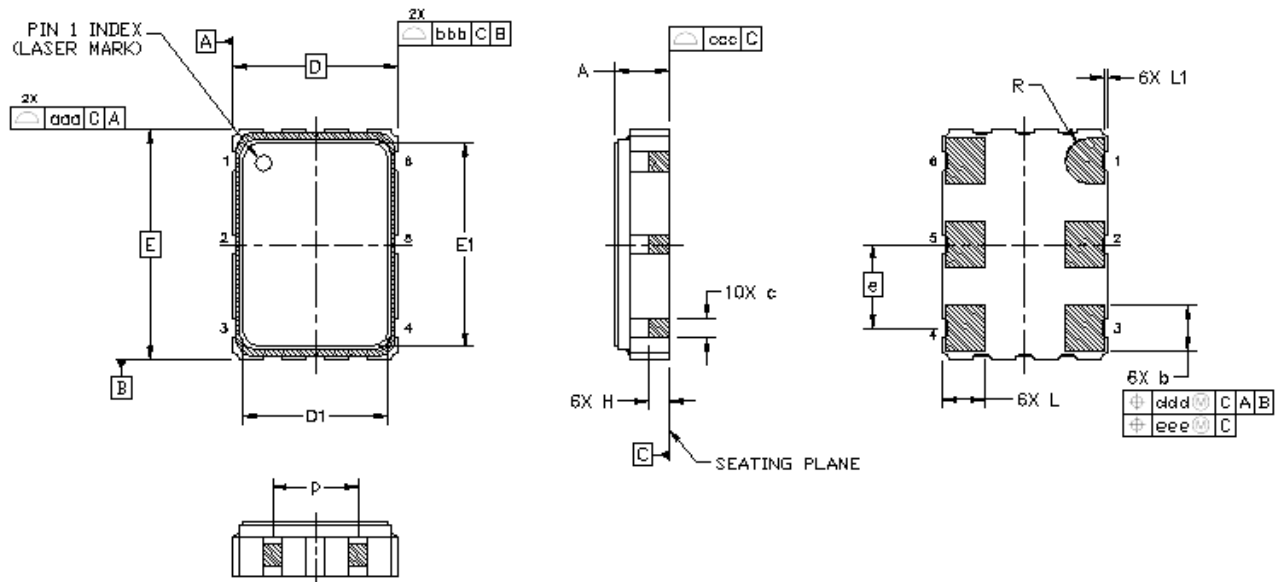

Figure 2. Si590/591 Outline Diagram

Table 11. Package Diagram Dimensions (mm)

Dimension	Min	Nom	Max
A	1.50	1.65	1.80
b	1.30	1.40	1.50
c	0.50	0.60	0.70
D	5.00 BSC		
D1	4.30	4.40	4.50
e	2.54 BSC		
E	7.00 BSC		
E1	6.10	6.20	6.30
H	0.55	0.65	0.75
L	1.17	1.27	1.37
L1	0.05	0.10	0.15
p	1.80	—	2.60
R	0.70 REF		
aaa	0.15		
bbb	0.15		
ccc	0.10		
ddd	0.10		
eee	0.05		

5. PCB Land Pattern: 5 x 7 mm, 6-pin

Figure 3 illustrates the 6-pin PCB land pattern for the 5 x 7 mm Si590/591. Table 12 lists the values for the dimensions shown in the illustration.

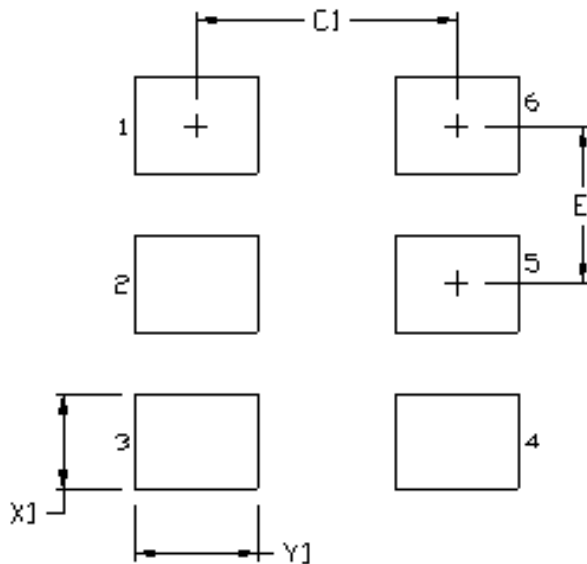

Figure 3. Si590/591 PCB Land Pattern

Table 12. PCB Land Pattern Dimensions (mm)

Dimension	(mm)
C1	4.20
E	2.54
X1	1.55
Y1	1.95

Notes:

General

1. All dimensions shown are in millimeters (mm) unless otherwise noted.
2. Dimensioning and Tolerancing is per the ANSI Y14.5M-1994 specification.
3. This Land Pattern Design is based on the IPC-7351 guidelines.
4. All dimensions shown are at Maximum Material Condition (MMC). Least Material Condition (LMC) is calculated based on a Fabrication Allowance of 0.05 mm.

Solder Mask Design

1. All metal pads are to be non-solder mask defined (NSMD). Clearance between the solder mask and the metal pad is to be 60 μ m minimum, all the way around the pad.

Stencil Design

1. A stainless steel, laser-cut and electro-polished stencil with trapezoidal walls should be used to assure good solder paste release.
2. The stencil thickness should be 0.125 mm (5 mils).
3. The ratio of stencil aperture to land pad size should be 1:1.

Card Assembly

1. A No-Clean, Type-3 solder paste is recommended.
2. The recommended card reflow profile is per the JEDEC/IPC J-STD-020 specification for Small Body Components.

6. Package Outline Drawing: 3.2 x 5 mm, 6-pin

Figure illustrates the package details for the 3.2 x 5 mm Si590/591. Table 13 lists the values for the dimensions shown in the illustration.

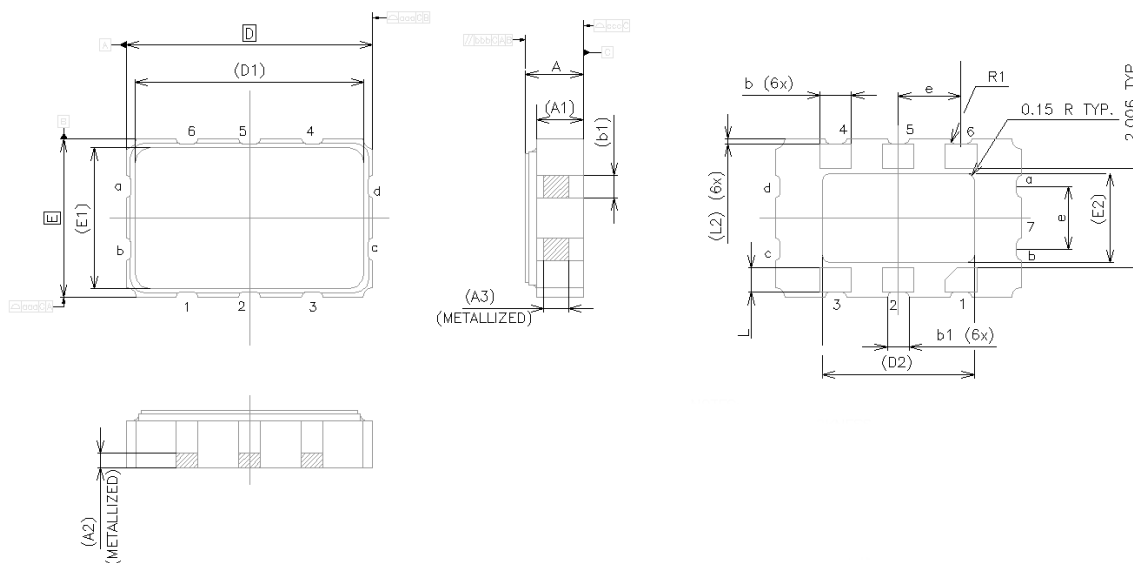

Figure 4. Si590/591 Outline Diagram

Table 13. Package Diagram Dimensions (mm)

Dimension	Min	Nom	Max	Dimension	Min	Nom	Max
A	1.02	1.17	1.32	E1	2.85 BSC		
A1	0.99	1.10	1.21	E2	1.91 BSC		
A2	0.5 BSC			L	0.35	0.45	0.55
A3	0.30 BSC			L2	0.05	0.10	0.15
b	0.54	0.64	0.74	R1	0.10 REF		
B1	0.35	0.45	0.55	aaa	0.15		
D	5.00 BSC			bbb	0.15		
D1	4.65 BSC			ccc	0.08		
D2	3.38 BSC			ddd	0.10		
e	1.27 BSC			eee	0.05		
E	3.20 BSC						

Notes:

- All dimensions shown are in millimeters (mm) unless otherwise noted.
- Dimensioning and Tolerancing per ANSI Y14.5M-1994.

7. PCB Land Pattern: 3.2 x 5 mm, 6-pin

Figure 5 illustrates the 6-pin PCB land pattern for the 3.2 x 5 mm Si590/591. Table 14 lists the values for the dimensions shown in the illustration.

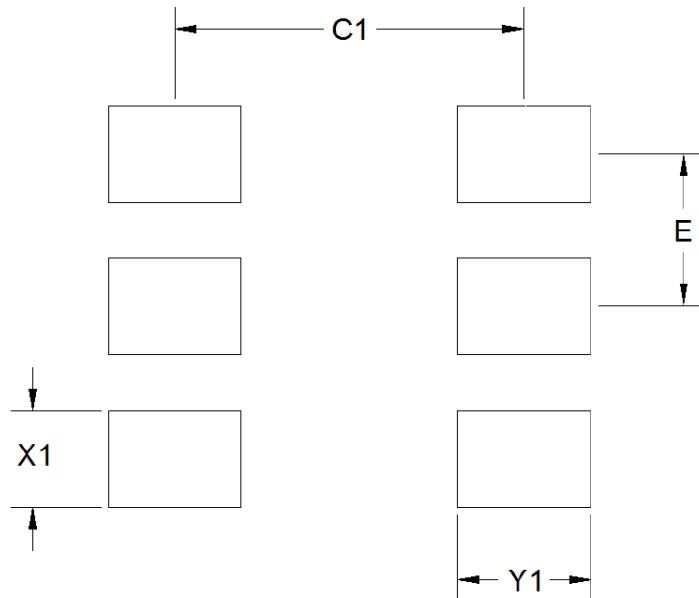

Figure 5. Si590/591 PCB Land Pattern

Table 14. PCB Land Pattern Dimensions (mm)

Dimension	(mm)
C1	2.91
E	1.27
X1	0.80
Y1	1.10

Notes:

General

1. All dimensions shown are in millimeters (mm) unless otherwise noted.
2. Dimensioning and Tolerancing is per the ANSI Y14.5M-1994 specification.
3. This Land Pattern Design is based on the IPC-7351 guidelines.
4. All dimensions shown are at Maximum Material Condition (MMC). Least Material Condition (LMC) is calculated based on a Fabrication Allowance of 0.05 mm.

Solder Mask Design

1. All metal pads are to be non-solder mask defined (NSMD). Clearance between the solder mask and the metal pad is to be 60 μm minimum, all the way around the pad.

Stencil Design

1. A stainless steel, laser-cut and electro-polished stencil with trapezoidal walls should be used to assure good solder paste release.
2. The stencil thickness should be 0.125 mm (5 mils).
3. The ratio of stencil aperture to land pad size should be 1:1.

Card Assembly

1. A No-Clean, Type-3 solder paste is recommended.
2. The recommended card reflow profile is per the JEDEC/IPC J-STD-020C specification for Small Body Components.

8. Si590/Si591 Top Marking: 5 x 7 mm

Figure 6 illustrates the mark specification for the 5 x 7 mm Si590/Si591. Table 15 lists the line information.

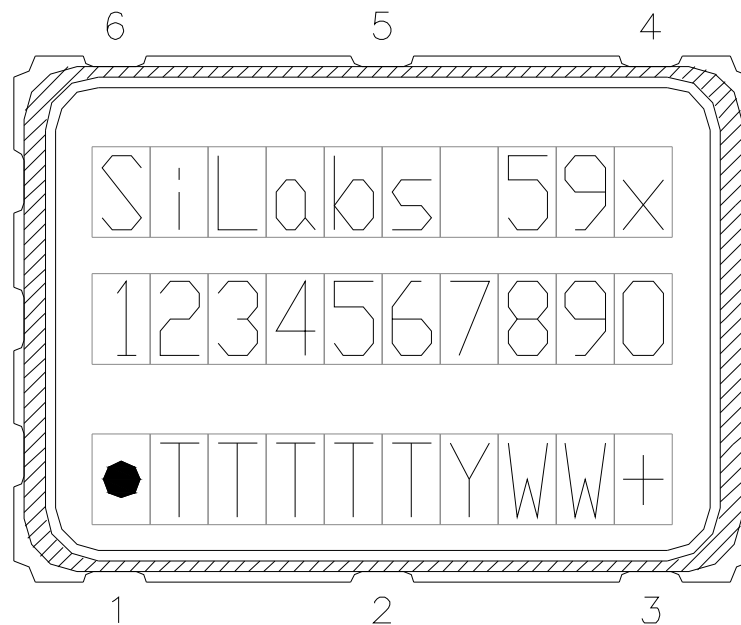

Figure 6. Top Mark Specification

Table 15. Si59x Top Mark Description

Line	Position	Description
1	1–10	“SiLabs”+ Part Family Number, 59x (First 3 characters in part number where x = 0 indicates a 590 device and x = 1 indicates a 591 device)
2	1–10	Si590, Si591: Option1 + Option2 + Freq(7) + Temp Si590/Si591 w/ 8-digit resolution: Option1 + Option2 + ConfigNum(6) + Temp
3	Trace Code	
	Position 1	Pin 1 orientation mark (dot)
	Position 2	Product Revision (D)
	Position 3–6	Tiny Trace Code (4 alphanumeric characters per assembly release instructions)
	Position 7	Year (least significant year digit), to be assigned by assembly site (ex: 2009 = 9)
	Position 8–9	Calendar Work Week number (1–53), to be assigned by assembly site
	Position 10	“+” to indicate Pb-Free and RoHS-compliant

Si590/591

9. Si590/Si591 Top Marking: 3.2 x 5 mm

Figure 7 illustrates the mark specification for the 3.2 x 5 mm Si590/Si591. Table 16 lists the line information.

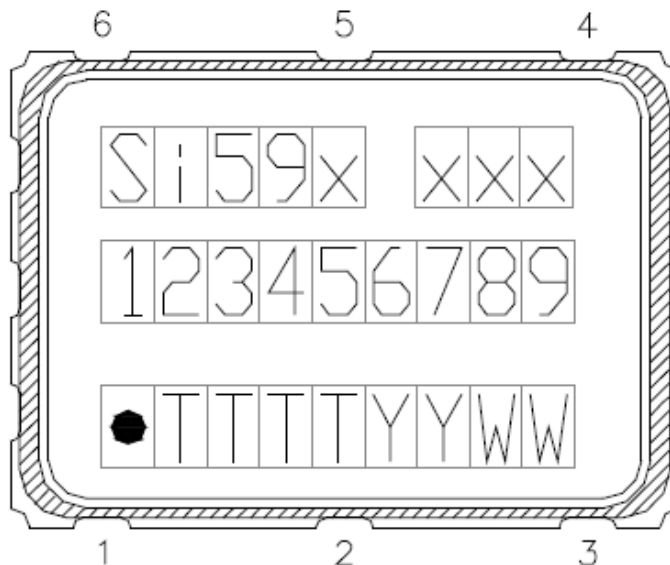

Figure 7. Top Mark Specification

Table 16. Si59x Top Mark Description

Line	Position	Description
1	1–5	“Si”+ Part Family Number, 59x (First 3 characters in part number where x = 0 indicates a 590 device and x = 1 indicates a 591 device)
	6–8	Crystal trace code (3 alphanumeric characters assigned by assembly site)
2	1–9	Si590, Si591: Option1 + Option2 + Freq(7) Si590/Si591 w/ 8-digit resolution: Option1 + Option2 + ConfigNum(6)
3	Trace Code	
	Position 1	Pin 1 orientation mark (dot)
	Position 2	Product Revision (D)
	Position 3–5	Tiny Trace Code (3 alphanumeric characters per assembly release instructions)
	Position 6–7	Year (last two digits of year), to be assigned by assembly site (ex: 20017 = 17)
	Position 8–9	Calendar Work Week number (1–53), to be assigned by assembly site

REVISION HISTORY

Revision 1.2

June, 2018

- Changed “Trays” to “Coil Tape” in 3. “Ordering Information” on page 8.

Revision 1.1

December, 2017

- Added 3.2 x 5 mm package.

Revision 1.0

- Updated 2.5 V/3.3 V and 1.8 V CML output level specifications in Table 3 on page 4.
- Updated Si590/591 devices to support frequencies up to 810 MHz for LVPECL, LVDS, and CML outputs.
- Separated 1.8 V, 2.5 V/3.3 V supply voltage. specifications for CML output in Table 3 on page 4.
- Updated Note 1 of Table 4 on page 4 to refer to AN256.
- Updated Table 4 on page 4.
 - Updated phase jitter specification.
- Updated Table 6 on page 5 to include the “Moisture Sensitivity Level” and “Contact Pads” rows.
- Updated Figure 3 and Table 15 on page 13 to reflect specific marking information.
- Added Table 7, “Thermal Characteristics,” on page 5.
- Rearranged sections to conform to new quality standard.

Revision 0.4

- Added ± 7 ppm temperature stability ordering option in Table 4 on page 4 and Figure 1 on page 8.

Revision 0.3

- Updated Table 4 on page 4 by adding the 155.51 MHz “Phase Jitter (RMS) (LVPECL/LVDS/CML)” row.
- Updated and clarified Table 6 on page 5 to correct typos and include the “Moisture Sensitivity Level” and “Contact Pads” rows.
- Corrected BSC value in rows D and E in Table 11 on page 9.

Revision 0.25

- Total Stability Maximum changed to ± 30 in Table 2 on page 3.
- Total Stability Maximum changed to ± 30 in Figure 1 on page 8.



SKYWORKS®

ClockBuilder Pro

Customize Skyworks clock generators, jitter attenuators and network synchronizers with a single tool. With CBPro you can control evaluation boards, access documentation, request a custom part number, export for in-system programming and more!

www.skyworksinc.com/CBPro



Portfolio

www.skyworksinc.com/ia/timing



SW/HW

www.skyworksinc.com/CBPro

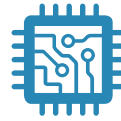

Quality

www.skyworksinc.com/quality



Support & Resources

www.skyworksinc.com/support

Copyright © 2021 Skyworks Solutions, Inc. All Rights Reserved.

Information in this document is provided in connection with Skyworks Solutions, Inc. ("Skyworks") products or services. These materials, including the information contained herein, are provided by Skyworks as a service to its customers and may be used for informational purposes only by the customer. Skyworks assumes no responsibility for errors or omissions in these materials or the information contained herein. Skyworks may change its documentation, products, services, specifications or product descriptions at any time, without notice. Skyworks makes no commitment to update the materials or information and shall have no responsibility whatsoever for conflicts, incompatibilities, or other difficulties arising from any future changes.

No license, whether express, implied, by estoppel or otherwise, is granted to any intellectual property rights by this document. Skyworks assumes no liability for any materials, products or information provided hereunder, including the sale, distribution, reproduction or use of Skyworks products, information or materials, except as may be provided in Skyworks' Terms and Conditions of Sale.

THE MATERIALS, PRODUCTS AND INFORMATION ARE PROVIDED "AS IS" WITHOUT WARRANTY OF ANY KIND, WHETHER EXPRESS, IMPLIED, STATUTORY, OR OTHERWISE, INCLUDING FITNESS FOR A PARTICULAR PURPOSE OR USE, MERCHANTABILITY, PERFORMANCE, QUALITY OR NON-INFRINGEMENT OF ANY INTELLECTUAL PROPERTY RIGHT; ALL SUCH WARRANTIES ARE HEREBY EXPRESSLY DISCLAIMED. SKYWORKS DOES NOT WARRANT THE ACCURACY OR COMPLETENESS OF THE INFORMATION, TEXT, GRAPHICS OR OTHER ITEMS CONTAINED WITHIN THESE MATERIALS. SKYWORKS SHALL NOT BE LIABLE FOR ANY DAMAGES, INCLUDING BUT NOT LIMITED TO ANY SPECIAL, INDIRECT, INCIDENTAL, STATUTORY, OR CONSEQUENTIAL DAMAGES, INCLUDING WITHOUT LIMITATION, LOST REVENUES OR LOST PROFITS THAT MAY RESULT FROM THE USE OF THE MATERIALS OR INFORMATION, WHETHER OR NOT THE RECIPIENT OF MATERIALS HAS BEEN ADVISED OF THE POSSIBILITY OF SUCH DAMAGE.

Skyworks products are not intended for use in medical, lifesaving or life-sustaining applications, or other equipment in which the failure of the Skyworks products could lead to personal injury, death, physical or environmental damage. Skyworks customers using or selling Skyworks products for use in such applications do so at their own risk and agree to fully indemnify Skyworks for any damages resulting from such improper use or sale.

Customers are responsible for their products and applications using Skyworks products, which may deviate from published specifications as a result of design defects, errors, or operation of products outside of published parameters or design specifications. Customers should include design and operating safeguards to minimize these and other risks. Skyworks assumes no liability for applications assistance, customer product design, or damage to any equipment resulting from the use of Skyworks products outside of Skyworks' published specifications or parameters.

Skyworks, the Skyworks symbol, Sky5®, SkyOne®, SkyBlue™, Skyworks Green™, Clockbuilder®, DSPLL®, ISOModem®, ProSLIC®, and SiPHY® are trademarks or registered trademarks of Skyworks Solutions, Inc. or its subsidiaries in the United States and other countries. Third-party brands and names are for identification purposes only and are the property of their respective owners. Additional information, including relevant terms and conditions, posted at www.skyworksinc.com, are incorporated by reference.

X-ON Electronics

Largest Supplier of Electrical and Electronic Components

Click to view similar products for [Standard Clock Oscillators](#) category:

Click to view products by [Skyworks](#) manufacturer:

Other Similar products are found below :

[601252](#) [F335-25](#) [F535L-33.333](#) [F535L-50](#) [NBXHBA019LN1TAG](#) [SiT1602BI-22-33E-50.000000E](#) [SIT8918AA-11-33S-50.000000G](#)
[SM4420TEV-40.0M-T1K](#) [F335-24](#) [F335-40](#) [F535L-10](#) [F535L-12](#) [F535L-24](#) [F535L-27](#) [PE7744DW-100.0M](#) [ASF1-3.686MHZ-N-K-S](#) [ASV-](#)
[4.000MHZ-LCS-T](#) [XLH735025.000JU4I8](#) [XLP725125.000JU6I8](#) [XO57CTECNA3M6864](#) [601251](#) [SiT8503AI-18-33E-0.200000X](#)
[SIT8918AA-11-33S-16.000000G](#) [SIT9122AI2C233E300.000000X](#) [9120AC-2D2-33E212.500000](#) [9102AI-243N25E100.00000](#) [8208AC-82-](#)
[18E-25.00000](#) [8008AI-72-XXE-24.545454E](#) [8004AC-13-33E-133.33000X](#) [AS-4.9152-16-SMD-TR](#) [ASFL1-48.000MHZ-LC-T](#)
[632L3I004M00000](#) [SIT8920AM-31-33E-25.0000](#) [DSC1028DI2-019.2000](#) [9121AC-2C3-25E100.00000](#) [9102AI-233N33E100.00000X](#)
[9102AI-233N25E200.00000](#) [9102AI-232H25S125.00000](#) [9102AI-133N25E200.00000](#) [9102AC-283N25E200.00000](#) [9001AC-33-33E1-30.000](#)
[8103AC-13-33E-12.00000X](#) [3921AI-2CF-33NZ125.000000](#) [5730-1SF](#) [XUN736000.032768I](#) [ASV-25.000MHZ-ECS-50-T](#) [EC3925ETTTS-](#)
[100.000M TR](#) [SIT1602BC-83-33E-10.000000Y](#) [8003AI-12-33S-40.00000Y](#) [1602BI-13-33S-19.200000E](#)