

DATA SHEET

ACA2429: 1218 MHz High-Output GaN CATV Power-Doubler Amplifier

Applications

- Advanced high-power, high-frequency HFC transmission systems
- Output power doubler for deep fiber node in CATV distribution
- CATV digital edge QAM output driver

Features

- 50 to 1218 MHz frequency range
- Output power: +59 dBmV
- Gain: 25 dB at 1218 MHz
- 1 dB tilt over bandwidth
- Single +24 V supply
- Operating current: 430 mA
- GaN amplifier technology
- Halogen-free/RoHS compliant

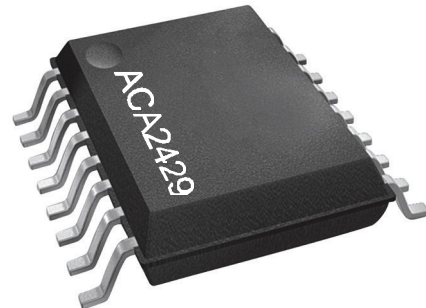

Description

The ACA2429 is a highly linear, high-output power integrated RF amplifier designed for CATV head-ends and HFC distribution systems. The IC consists of two parallel amplifiers that are optimized for exceptionally low distortion, high-output power, and high crash-point in a thermally enhanced surface-mount package. A GaN output stage is incorporated to minimize the operating (bias) current, thus making this an excellent choice for environmentally friendly "green" initiatives. The ACA2429 provides high gain over the 50 to 1218 MHz CATV downstream band, and is cascaded between two transmission line baluns.

A block diagram of the ACA2429 is shown in Figure 1. The device package and pinout are shown in Figure 2. Signal pin assignments and functional pin descriptions are described in Table 1.



Skyworks Green™ products are compliant with all applicable legislation and are halogen-free. For additional information, refer to *Skyworks Definition of Green™*, document number SQ04-0074.

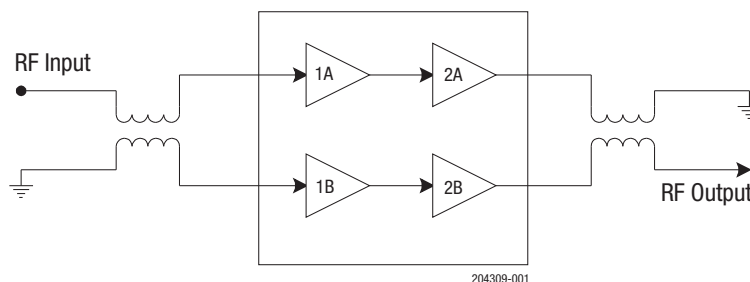

Figure 1. ACA2429 Block Diagram

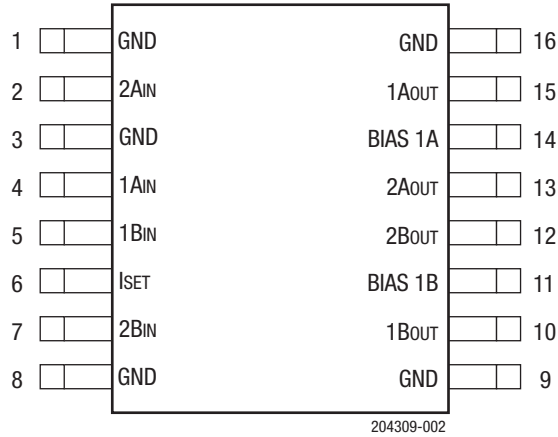

Figure 2. ACA2429 Pinout (Top View)

Table 1. ACA2429 Signal Pin Descriptions

Pin	Name	Description	Pin	Name	Description
1	GND	Ground	9	GND	Ground
2	2AIN	Amplifier 2A input	10	1BOUT	Amplifier 1B output
3	GND	Ground	11	BIAS 1B	Bias for 1B amplifier
4	1AIN	Amplifier 1A input	12	2BOUT	Amplifier 2B output and supply
5	1BIN	Amplifier 1B input	13	2AOUT	Amplifier 2A output and supply
6	ISET	Current adjust	14	BIAS 1A	Bias for 1A amplifier
7	2BIN	Amplifier 2B input	15	1AOUT	Amplifier 1A output
8	GND	Ground	16	GND	Ground

Electrical and Mechanical Specifications

The absolute maximum ratings of the ACA2429 are provided in Table 2. Recommended operating conditions are specified in Table 3, and electrical specifications are provided in Table 4.

Table 2. ACA2429 Absolute Maximum Ratings¹

Parameter	Minimum	Maximum	Units
Supply (pins 12 and 13)	0	+28	VDC
Current adjust (pin 6)		+4	VDC
RF power at inputs (pins 4 and 5)		+75	dBmV
Case operating temperature (Tc)	-40	+110	°C
Storage temperature	-65	+150	°C
Soldering temperature		+260	°C
Soldering time		5.0	sec

¹ Exposure to maximum rating conditions for extended periods may reduce device reliability. There is no damage to device with only one parameter set at the limit and all other parameters set at or below their nominal value. Exceeding any of the limits listed here may result in permanent damage to the device.

² Pins 2, 4, 5, and 7 should be AC coupled. No external DC bias should be applied.

³ Pin 6 should be AC-grounded and/or pulled to ground through a resistor for current control.

⁴ Pins 10, 11, 14, and 15 should have no other external bias applied.

ESD HANDLING: *Although this device is designed to be as robust as possible, electrostatic discharge (ESD) can damage this device. This device must be protected at all times from ESD when handling or transporting. Static charges may easily produce potentials of several kilovolts on the human body or equipment, which can discharge without detection. Industry-standard ESD handling precautions should be used at all times.*

Table 3. ACA2429 Recommended Operating Conditions¹

Parameter	Symbol	Min	Typ	Max	Units
RF input/output frequency	f	50		1218	MHz
Supply voltage	V _{DD}		+24		VDC
Current adjust (pin 15)			+1.5		VDC
Case temperature	T _{CASE}	-40		+100	°C

¹ Performance is guaranteed only under the conditions listed in this table.

Table 4. ACA2429 Electrical Specifications^{1,3,4}

(TA = +25 °C, VDD = +24 VDC, f = 50 to 1218 MHz, 75 Ω System, Unless Otherwise Noted)

Parameter	Symbol	Test Condition	Min	Typ	Max	Units
Gain ³	G	1218 MHz	24.5	25.25	26	dB
Gain flatness to 1218 MHz ^{2,3}				± 0.2		dB
Cable equivalent slope ³				1		dB
Noise figure	NF			5		dB
Composite triple beat ¹	CTB			-78	-74	dBc
Composite second order ¹	CSO			-66	-64	dBc
Composite intermodulation noise ¹	CIN			-60	-56	dB
Input return loss ³	RL			-20	-18	dB
Output return loss ³	RL			-20	-18	dB
Thermal resistance	θ _{Jc}	Junction-to-case slug		2.7	3.3	°C/W
Supply current			400	430	470	mA

¹ Parts measured with 79 NTSC analog channels plus digital QAM channels to 1000 MHz, +58 dBmV output power and 15.5 dB tilt referenced to 1 GHz.

² Peak deviation from a straight line between gain value at 50 MHz and 1218 MHz.

³ Measured in application circuit in Figure 3.

⁴ All specifications as measured on the Evaluation Board.

Evaluation Board Description

The ACA2429 Evaluation Board is used to test the performance of the ACA2429 device. An Evaluation Board schematic is provided

in Figure 3. Table 5 provides the Bill of Materials (BOM) list for Evaluation Board components.

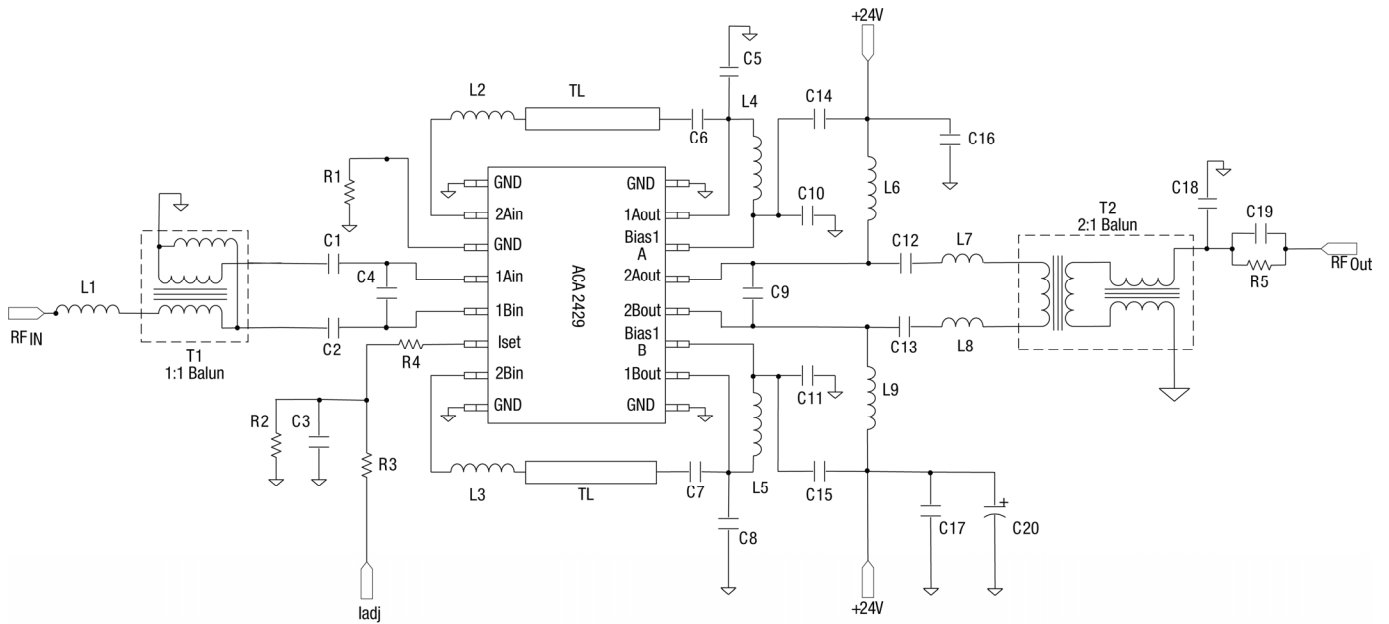

Figure 3. ACA2429 Evaluation Board Schematic

Table 5. ACA2429 Evaluation Board Bill of Materials (BOM)

Component	Value	Mfr	Mfr Part Number
C1, C2, C3, C16, C17	0.01 uF	Murata	GRM155R71H103KA
C4	0.5 pF	Murata	GRM1555C1HR50BA01D
C5, C8	1.3 pF	Murata	GRM1555C1H1R3BA01D
C6, C7	270 pF	Murata	GRM1555C1H271JA01D
C9	0.1 uF	Murata	GRM1555C1HR104BA01D
C10, C11, C14, C15	4700 pF	Murata	GRM155R71H472JA01D
C12, C13	150 pF	Murata	GRM1555C1H151JA01D
C18	0.2 pF	Murata	GRM1555C1HR20BA01D
C19	68 pF	Murata	GRM1555C1H680FA01D
C20	47 uF	Panasonic	ECE-A1HN470UB
L1	1.0 nH	Murata	LQG15HN1N0S02D
L2, L3	2.2 nH	Murata	LQG15HN2N2S02D
L4, L5	470 nH	Murata	LQH31CNR47M03L
L6, L9	680 nH	Allied	LS03-R68J-RC
L7, L8	0 Ω	KOA Speer	RK73Z1ETTP
R1, R4	0 Ω	KOA Speer	RK73Z1ETTP
R2	1.2 kΩ	KOA Speer	RK73H1JTTD1201F
R3	DNI	DNI	DNI
R5	8.25 Ω	KOA Speer	RK73H1ETTP8R25F
T1	1:1 transformer	Mintronix	MRF-25001
T2	2:1 transformer	Mintronix	MRF-27001
U1			ACA2429
PCB			11G21A75_B10

Package Dimensions

The PCB layout footprint drawing for the ACA2429 is shown in Figure 5. The package dimensions for the ACA2429 are shown in Figure 6. The tape and reel dimensions are provided in Figure 7.

Package and Handling Information

Since the device package is sensitive to moisture absorption, it is baked and vacuum packed before shipping. Instructions on the shipping container label regarding exposure to moisture after the container seal is broken must be followed. Otherwise, problems related to moisture absorption may occur when the part is subjected to high temperature during solder assembly.

The ACA2429 is rated to Moisture Sensitivity Level 2 (MSL2) at 260 °C. It can be used for lead or lead-free soldering. For additional information, refer to the Skyworks Application Note, *Solder Reflow Information*, document number 200164.

Care must be taken when attaching this product, whether it is done manually or in a production solder reflow environment. Production quantities of this product are shipped in a standard tape and reel format.

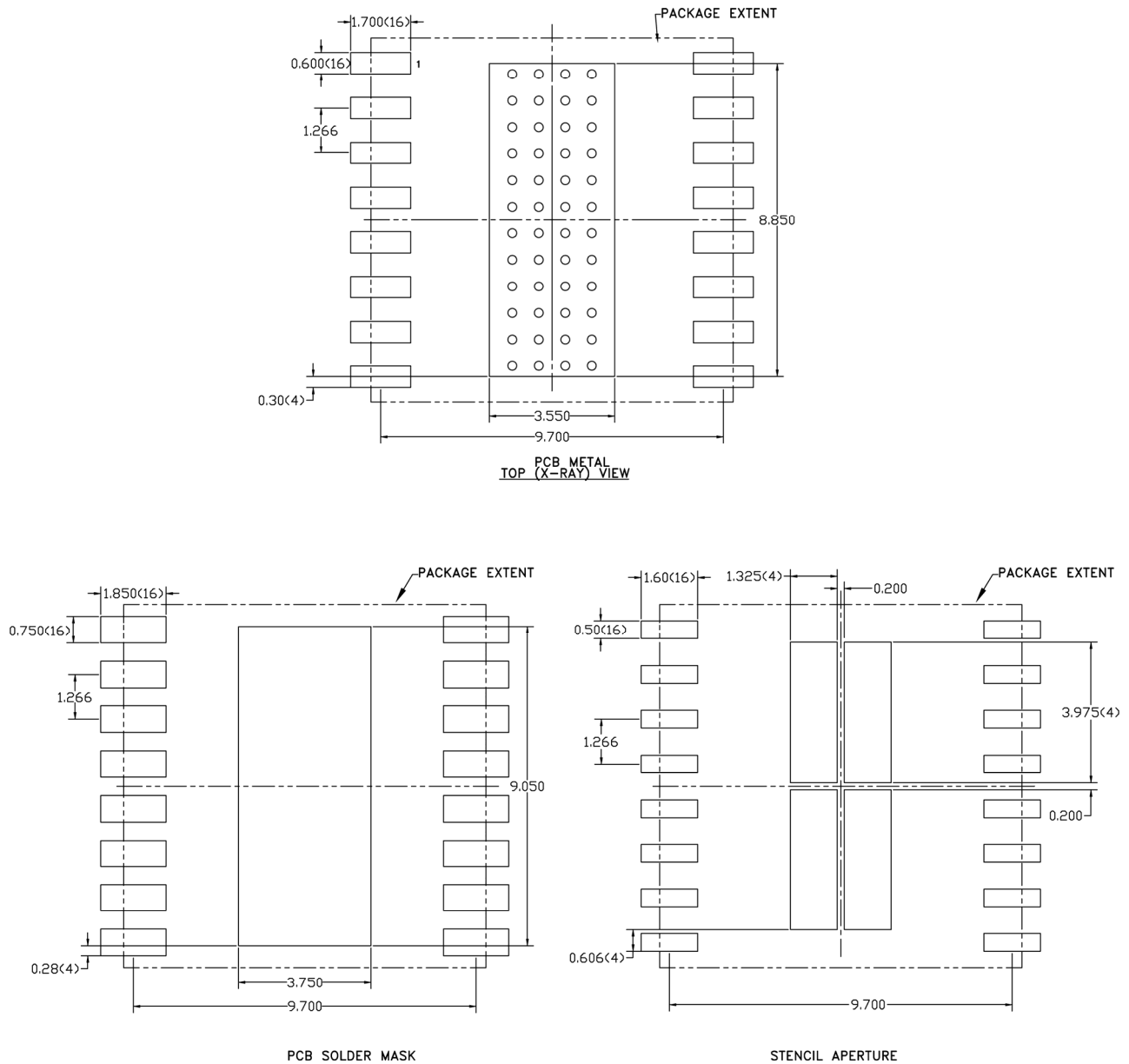

NOTES:

- (1) UNLESS SPECIFIED DIMENSIONS ARE SYMMETRICAL ABOUT CENTER LINES SHOWN.
- (2) DIMENSIONS IN MILLIMETERS.
- (3) VIAS SHOWN IN PCB METAL VIEW ARE FOR REFERENCE ONLY. NUMBER & SIZE OF THERMAL VIAS REQUIRED DEPENDENT ON HEA DISSIPATION REQUIREMENT AND THE PC PROC SS CAPABILITY.
- (4) RECOMMENDED STENCIL THICKNESS: APPROX. 0.125mm (5 Mils)

204208-005

Figure 5. ACA2429 PCB Layout Footprint Dimensions

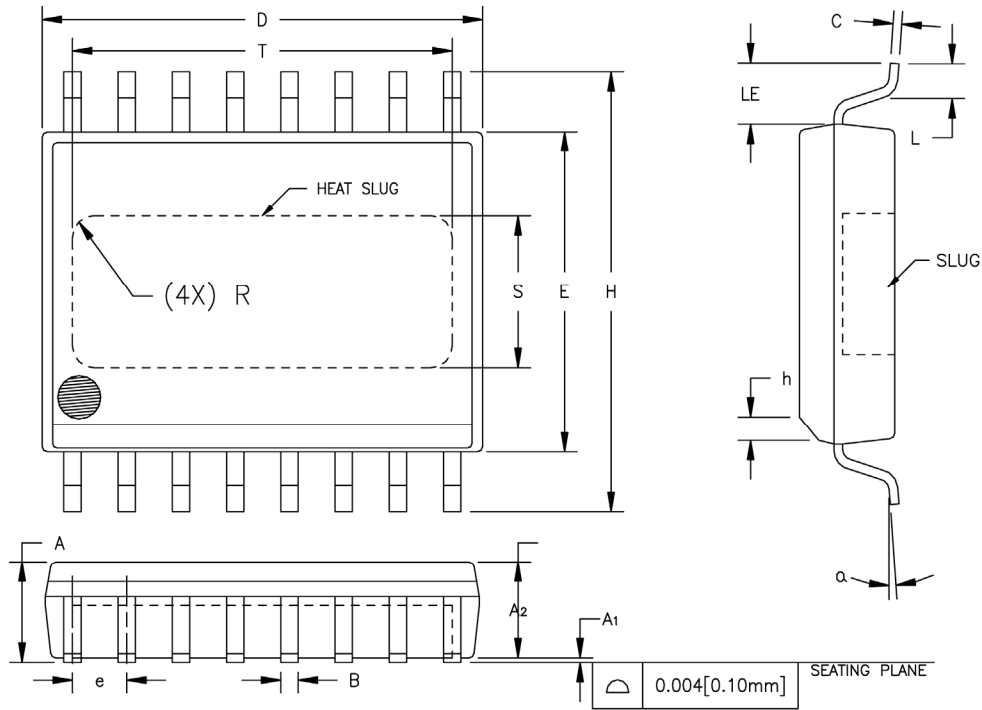

SYMBOL	INCHES		MILLIMETERS		NOTE
	MIN.	MAX.	MIN.	MAX.	
A	0.087	0.098	2.21	2.49	
A ₁	0.000	0.004	0.00	0.10	6
A ₂	0.087	0.094	2.21	2.39	
B	0.013	0.019	0.33	0.48	
C	0.007	0.009	0.18	0.23	
D	0.398	0.412	10.11	10.46	2
E	0.290	0.300	7.37	7.62	3
e	0.050	BSC	1.27	BSC	4
H	0.394	0.418	10.01	10.62	
h	0.010	0.028	0.25	0.71	
L	0.024	0.040	0.61	1.02	
LE	0.052	—	1.32	—	
α	0°	8°	0°	8°	
S	0.120	0.140	3.05	3.56	5
T	0.330	0.350	8.38	8.89	5
R	REF.	0.015	REF.	0.38	5

NOTES:

1. CONTROLLING DIMENSION: INCHES
2. DIMENSION "D" DOES NOT INCLUDE MOLD FLASH, PROTRUSIONS OR GATE BURRS. MOLD FLASH, PROTRUSIONS AND GATE BURRS SHALL NOT EXCEED 0.006 [0.15mm] PER SIDE.
3. DIMENSION "E" DOES NOT INCLUDE INTER-LEAD FLASH OR PROTRUSIONS. INTER-LEAD FLASH AND PROTRUSIONS SHALL NOT EXCEED 0.010 [0.25mm] PER SIDE.
4. MAXIMUM LEAD TWIST/SKEW TO BE ±0.005 [0.13mm].
5. DIMENSIONS "S", "T" AND "R" INDICATE EXPOSED SLUG AREA.
6. STANDOFF HEIGHT (A₁) MEASURED FROM BOTTOM OF SLUG.

204208-006

Figure 6. ACA2429 Package Dimensions

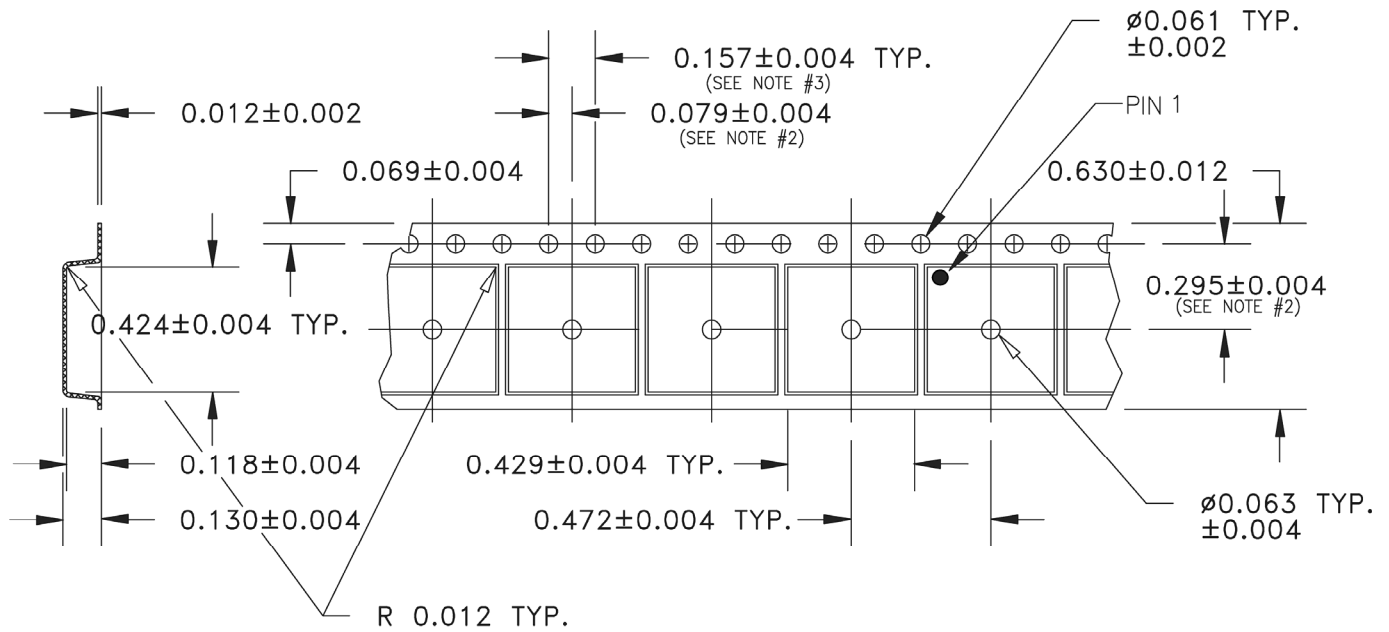

- NOTES: 1. MATERIAL – CONDUCTIVE POLYSTYRENE.
 2. MEASURED FROM CENTERLINE OF SPROCKET HOLE TO CENTERLINE OF POCKET.
 3. CUMULATIVE TOLERANCE OF 10 SPROCKET HOLES IS ± 0.008.

204208-007

Figure 7. ACA2429 Tape and Reel Dimensions

Ordering Information

Part Number	Product Description	Packaging
ACA2429P2	16-pin wide body SOIC with heat slug	1500-piece tape and reel
EVB2429	Evaluation Board	

Copyright © 2016-2019 Skyworks Solutions, Inc. All Rights Reserved.

Information in this document is provided in connection with Skyworks Solutions, Inc. (“Skyworks”) products or services. These materials, including the information contained herein, are provided by Skyworks as a service to its customers and may be used for informational purposes only by the customer. Skyworks assumes no responsibility for errors or omissions in these materials or the information contained herein. Skyworks may change its documentation, products, services, specifications or product descriptions at any time, without notice. Skyworks makes no commitment to update the materials or information and shall have no responsibility whatsoever for conflicts, incompatibilities, or other difficulties arising from any future changes.

No license, whether express, implied, by estoppel or otherwise, is granted to any intellectual property rights by this document. Skyworks assumes no liability for any materials, products or information provided hereunder, including the sale, distribution, reproduction or use of Skyworks products, information or materials, except as may be provided in Skyworks Terms and Conditions of Sale.

THE MATERIALS, PRODUCTS AND INFORMATION ARE PROVIDED “AS IS” WITHOUT WARRANTY OF ANY KIND, WHETHER EXPRESS, IMPLIED, STATUTORY, OR OTHERWISE, INCLUDING FITNESS FOR A PARTICULAR PURPOSE OR USE, MERCHANTABILITY, PERFORMANCE, QUALITY OR NON-INFRINGEMENT OF ANY INTELLECTUAL PROPERTY RIGHT; ALL SUCH WARRANTIES ARE HEREBY EXPRESSLY DISCLAIMED. SKYWORKS DOES NOT WARRANT THE ACCURACY OR COMPLETENESS OF THE INFORMATION, TEXT, GRAPHICS OR OTHER ITEMS CONTAINED WITHIN THESE MATERIALS. SKYWORKS SHALL NOT BE LIABLE FOR ANY DAMAGES, INCLUDING BUT NOT LIMITED TO ANY SPECIAL, INDIRECT, INCIDENTAL, STATUTORY, OR CONSEQUENTIAL DAMAGES, INCLUDING WITHOUT LIMITATION, LOST REVENUES OR LOST PROFITS THAT MAY RESULT FROM THE USE OF THE MATERIALS OR INFORMATION, WHETHER OR NOT THE RECIPIENT OF MATERIALS HAS BEEN ADVISED OF THE POSSIBILITY OF SUCH DAMAGE.

Skyworks products are not intended for use in medical, lifesaving or life-sustaining applications, or other equipment in which the failure of the Skyworks products could lead to personal injury, death, physical or environmental damage. Skyworks customers using or selling Skyworks products for use in such applications do so at their own risk and agree to fully indemnify Skyworks for any damages resulting from such improper use or sale.

Customers are responsible for their products and applications using Skyworks products, which may deviate from published specifications as a result of design defects, errors, or operation of products outside of published parameters or design specifications. Customers should include design and operating safeguards to minimize these and other risks. Skyworks assumes no liability for applications assistance, customer product design, or damage to any equipment resulting from the use of Skyworks products outside of stated published specifications or parameters.

Skyworks and the Skyworks symbol are trademarks or registered trademarks of Skyworks Solutions, Inc. or its subsidiaries in the United States and other countries. Third-party brands and names are for identification purposes only, and are the property of their respective owners. Additional information, including relevant terms and conditions, posted at www.skyworksinc.com, are incorporated by reference.

X-ON Electronics

Largest Supplier of Electrical and Electronic Components

Click to view similar products for [RF Amplifier](#) category:

Click to view products by [Skyworks](#) manufacturer:

Other Similar products are found below :

[A82-1](#) [BGA622H6820XTSA1](#) [BGA 728L7 E6327](#) [BGB719N7ESDE6327XTMA1](#) [HMC397-SX](#) [HMC405](#) [HMC561-SX](#) [HMC8120-SX](#)
[HMC8121-SX](#) [HMC-ALH382-SX](#) [HMC-ALH476-SX](#) [SE2433T-R](#) [SMA3101-TL-E](#) [SMA39](#) [A66-1](#) [A66-3](#) [A67-1](#) [A81-2](#) [LX5535LQ](#)
[LX5540LL](#) [MAAM02350](#) [HMC3653LP3BETR](#) [HMC549MS8GETR](#) [HMC-ALH435-SX](#) [SMA101](#) [SMA32](#) [SMA411](#) [SMA531](#)
[SST12LP19E-QX6E](#) [WPM0510A](#) [HMC5929LS6TR](#) [HMC5879LS7TR](#) [HMC1087F10](#) [HMC1086](#) [HMC1016](#) [SMA1212](#) [MAX2689EWS+T](#)
[MAAMSS0041TR](#) [MAAM37000-A1G](#) [LTC6430AIUF-15#PBF](#) [SMA70-2](#) [SMA4011](#) [A231](#) [HMC-AUH232](#) [LX5511LQ](#) [LX5511LQ-TR](#)
[HMC7441-SX](#) [HMC-ALH310](#) [XD1001-BD-000V](#) [A4011](#)