

2.4GHz High Power 802.11ac WLAN Linear Power Amplifier

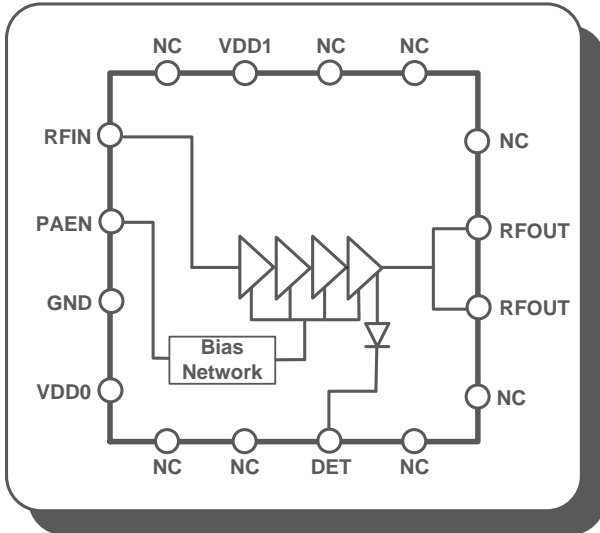

DESCRIPTION

The RFX242 is high power, high linearity power amplifier implemented in CMOS process. The device is optimized to provide all functionality of transmit power amplification for IEEE 802.11b/g/n/ac applications in the 2.4GHz frequency range.

The RFX242 provides 30dB gain and up to 25dBm linear output power with low EVM of <3% for 802.11n MCS7 HT40 and <1.8% for 802.11ac MCS9 VHT20 signals. It has CMOS logic control, on-chip input impedance matching, as well as integrated RF decoupling for the power supply.

The RFX242 is assembled in a compact 3.0x3.0mm 16L-QFN package.

It requires minimal number of external components to greatly simplify RF front-end implementation.

APPLICATIONS

- ▶ High Power WLAN AP/Router
- ▶ Outdoor WLAN Hotspots
- ▶ Wi-Fi Extenders
- ▶ Set-Top Box / Home Gateway
- ▶ FemtoCell
- ▶ Enterprise/SOHO Wi-Fi Networks

FEATURES

- ▶ 2.4GHz, Single Chip, Single-Die RF Power Amplifier
- ▶ 2.4GHz High Power PA with Low-Pass Harmonic Filter
- ▶ 802.11ac 256-QAM Support with <1.8% EVM up to 23dBm or <3% up to 25dBm at 5V
- ▶ High Gain of 30dB
- ▶ High Transmit Signal Linearity Meeting Standards for OFDM and CCK modulation
- ▶ Integrated Power Detector for Transmit Power Monitor and Control
- ▶ Compatible with Low Voltage (1.2V) CMOS Control Logic or levels up to VDD
- ▶ ESD Protection Circuitry on All Ports
- ▶ DC Decoupled RF Ports
- ▶ Internal RF Decoupling on All VDD Bias Pins
- ▶ Very Low DC Power Consumption
- ▶ Full On-chip Matching and Decoupling Circuitry
- ▶ Minimal External Components Required
- ▶ 50-Ohm Input / Output Matching
- ▶ 3 x 3 x 0.55mm Small Outline QFN-16 Package with Exposed Ground Pad

DEVICE PIN-OUT DIAGRAM

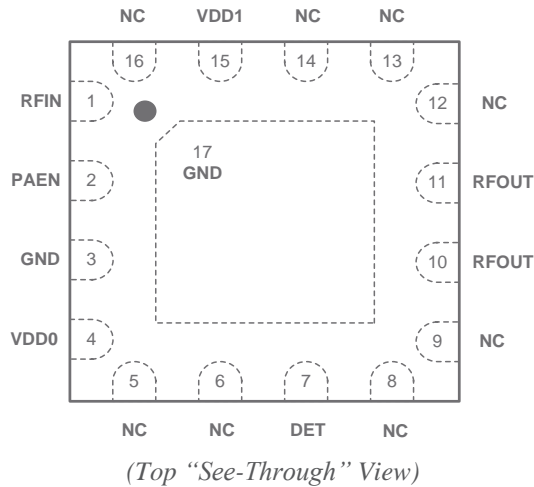

DEVICE PIN-OUT ASSIGNMENT

Pin Number	Pin Name	Description
1	RFIN	RF Input Signal to the PA
2	PAEN	CMOS Logic control to Enable the PA
3	GND	Ground – Must be connected to Ground in the Application Circuit
4, 15	VDD0 – VDD1	DC voltage supply
7	DET	PA Power Detector Voltage Output
10, 11	RFOUT	RF Output Signal from the PA
5, 6, 8, 9, 12, 13, 14, 16	NC	Not Connected

CONTROL LOGIC TRUTH TABLE

PAEN	Mode of Operation
0	PA is OFF; Device in Standby
1	PA is Enabled

Note: "1" denotes high voltage stage (>1.2V) at PAEN Control Pin;
"0" denotes low voltage stage (<0.3V) at PAEN Control Pin

ABSOLUTE MAXIMUM RATINGS

Parameters	Min	Max	Units	Conditions
DC VDD Voltage Supply	0	6.0	V	All VDD Pins
DC Control Pin Voltage	0	3.6	V	All Control Pins
DC VDD Current Consumption		800	mA	VDD Pins when PA is Enabled
TX RF Input Power		+10	dBm	
ANT RF Input Power		+10	dBm	
Junction Temperature		150	°C	
Storage Ambient Temperature	-50	+150	°C	Appropriate care required according to JEDEC Standards
Operating Ambient Temperature	-40	+85	°C	All Operating Modes
ESD Voltage (HBM)	1000		V	Human Body Model

Note: Sustained operation at or above the Absolute Maximum Ratings for any single or combinations of the above parameters may result in permanent damage to the device and is not recommended. All Maximum RF Input Power Ratings assume 50-Ohm terminal impedance.

GENERAL CHARACTERISTICS

Parameters	Min	Typ	Max	Units	Conditions
Operating Frequency	2.4		2.5	GHz	
DC VDD Voltage Supply (Note 1)	4.5	5.0	5.5	V	All VDD Pins
Control Voltage “High”	1.2		3.6	V	
Control Voltage “Low”		0	0.3	V	
Control Pin Current Consumption		1		μA	
DC Shutdown Current		5		μA	
PA Turn On/Off Time			1	μsec	
Input Single-Ended Impedance		50		Ω	
θ_{ja} (Note 2)		25		°C/W	
θ_{jc} Bottom (Note 3)		3.5		°C/W	For Indication Only
θ_{jc} Top (Note 3)		15		°C/W	For Indication Only

Note 1 – For normal operation of the RFX242, VDD must be continuously applied to all VDD supply pins.

Note 2 – For operation above +85 °C, use the θ_{ja} as guidance for system design to assure the junction temperature will not exceed the maximum of +150 °C.

Note 3 – θ_{jc} is provided for indication only. System operational design must be based on θ_{ja} .

TRANSMIT CHARACTERISTICS (VDD = 5.0V, PAEN = HI, T_A = +25°C, UNLESS OTHERWISE SPECIFIED, AS MEASURED ON RFX242 EVALUATION BOARD, DE-EMBEDDED TO THE DEVICE)

Parameters	Min	Typ	Max	Units	Conditions
Operating Frequency Band	2.4		2.5	GHz	All RF Pins Terminated by 50 Ohms
Output P1dB		+31		dBm	CW
Linear Output Power (802.11ac)		+23		dBm	802.11ac MCS9 VHT20 < -35dB DEVM
Linear Output Power (802.11n)		+25		dBm	802.11n MCS7 HT40 < -30dB DEVM
Linear Output Power (802.11b)		+29		dBm	1Mbps CCK Mask Compliance
Small-Signal Gain		32		dB	CW
Second Harmonic		-70		dBc	P _{OUT} = +29dBm, CW
Third Harmonic		-70		dBc	P _{OUT} = +29dBm, CW
Input Return Loss		-15		dB	At RFIN Pin
Output Return Loss		-5		dB	At RFOUT Pins
TX Quiescent Current		240		mA	No RF Input Signal
TX Linear Current		430		mA	P _{OUT} = +25dBm, 11n MCS7 64-QAM
Power Detector Voltage Output		0.3-1		V	P _{OUT} = +5 to +27 dBm, 10KΩ Load
Load VSWR for Stability (CW, Fix Pin for P _{OUT} = +29dBm with 50Ω Load)	4:1	6:1		N/A	All non-harmonically related spurs less than -43 dBm/Hz
Load VSWR for Ruggedness (CW, Fix Pin for P _{OUT} = +29dBm with 50Ω Load)	8:1	10:1		N/A	No damage

PACKAGE DIMENSIONS

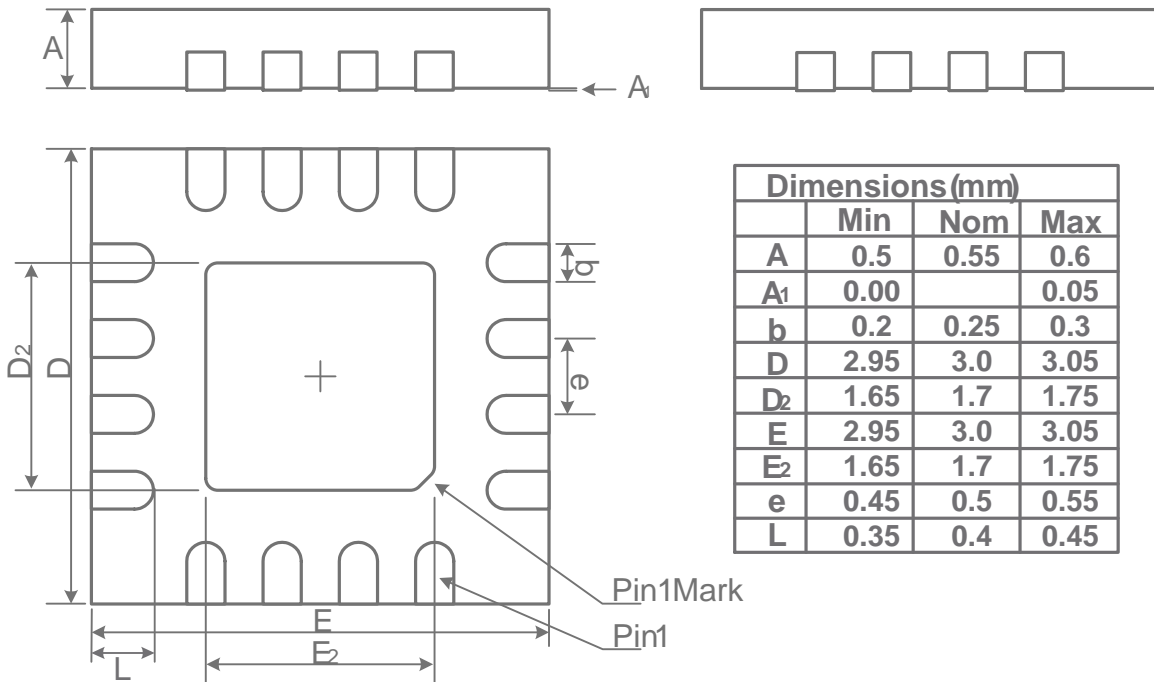

PACKAGE MARKING

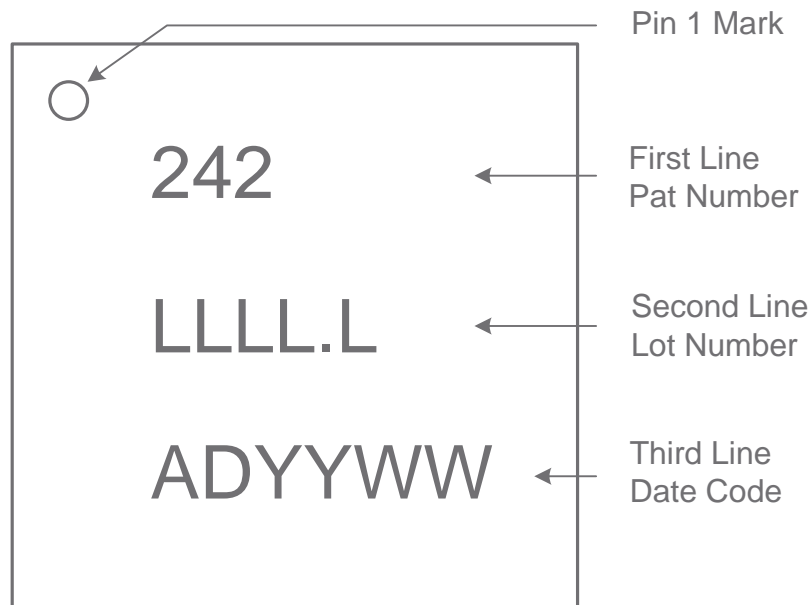

TAPE AND REEL INFORMATION:

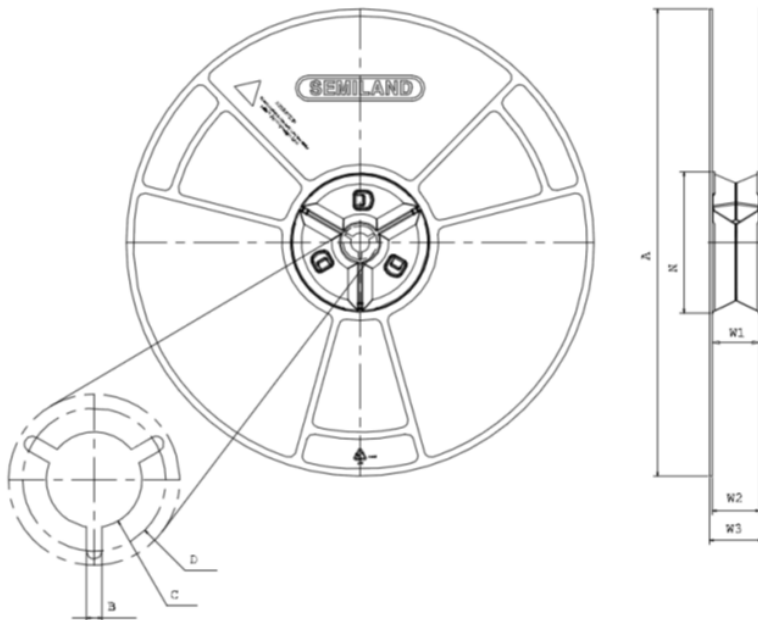
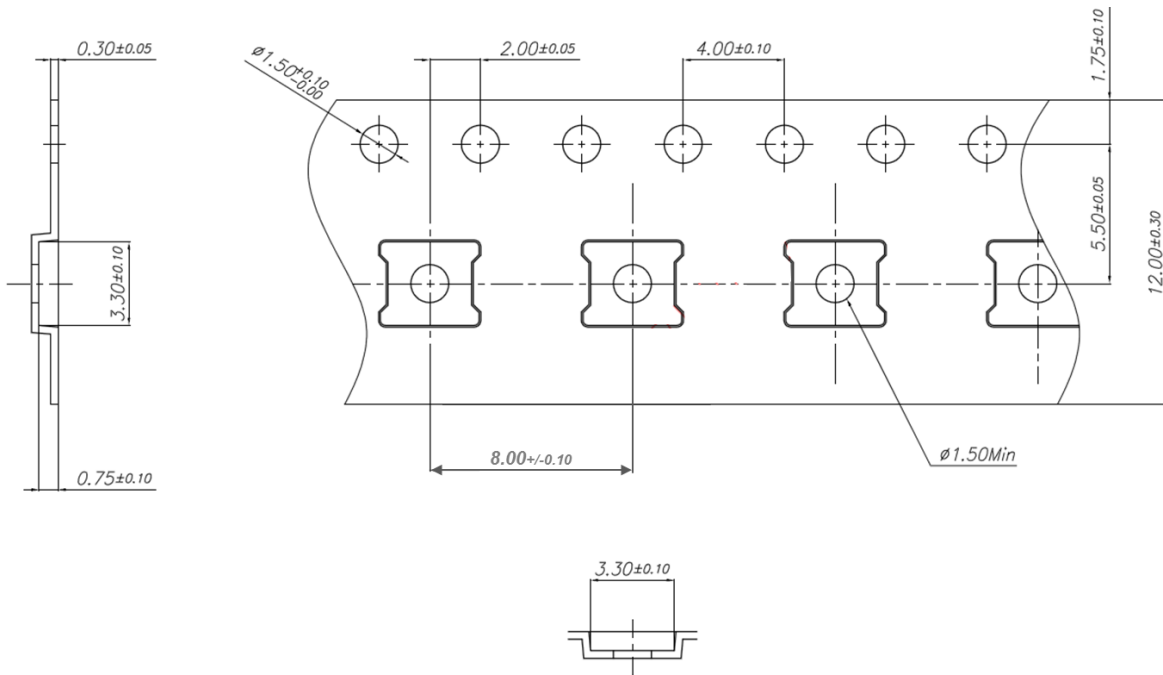

Size	12mm
A	330 ^{+0.2} _{-2.0}
B	1.5min
C	13.0 ^{+0.5} _{-0.2}
D	20.2min
N	100 ^{+2.0} _{-0.0}
W1	12.4 ^{+3.0} _{-0.0}
W2	12.4 ^{+3.0} _{-0.0}
W3	16.4 ^{+2.0} _{-2.0}
PART#	SRL-12134H

X-ON Electronics

Largest Supplier of Electrical and Electronic Components

Click to view similar products for [RF Development Tools](#) category:

Click to view products by [Skyworks](#) manufacturer:

Other Similar products are found below :

[MAAM-011117](#) [MAAP-015036-DIEEV2](#) [EV1HMC1113LP5](#) [EV1HMC6146BLC5A](#) [EV1HMC637ALP5](#) [EVAL-ADG919EBZ](#) [ADL5363-EVALZ](#) [LMV228SDEVAL](#) [SKYA21001-EVB](#) [SMP1331-085-EVB](#) [EV1HMC618ALP3](#) [EVAL01-HMC1041LC4](#) [MAAL-011111-000SMB](#)
[MAAM-009633-001SMB](#) [107712-HMC369LP3](#) [107780-HMC322ALP4](#) [SP000416870](#) [EV1HMC470ALP3](#) [EV1HMC520ALC4](#)
[EV1HMC244AG16](#) [124694-HMC742ALP5](#) [SC20ASATEA-8GB-STD](#) [MAX2837EVKIT+](#) [MAX2612EVKIT#](#) [MAX2692EVKIT#](#)
[SKY12343-364LF-EVB](#) [108703-HMC452QS16G](#) [EV1HMC863ALC4](#) [EV1HMC427ALP3E](#) [119197-HMC658LP2](#) [EV1HMC647ALP6](#)
[ADL5725-EVALZ](#) [106815-HMC441LM1](#) [EV1HMC1018ALP4](#) [UXN14M9PE](#) [MAX2016EVKIT](#) [EV1HMC939ALP4](#) [MAX2410EVKIT](#)
[MAX2204EVKIT+](#) [EV1HMC8073LP3D](#) [SIMSA868-DKL](#) [SIMSA868C-DKL](#) [SKY65806-636EK1](#) [SKY68020-11EK1](#) [SKY67159-396EK1](#)
[SKY66181-11-EK1](#) [SKY65804-696EK1](#) [SKY13396-397LF-EVB](#) [SKY13380-350LF-EVB](#) [SKY13373-460LF-EVB](#)