

DATA SHEET
SE2564L: 2.4 GHz High Efficiency Wireless LAN Front-End

Applications

- IEEE802.11b DSSS WLAN
- IEEE802.11g,n OFDM WLAN
- Access Points, PCMCIA, PC cards

Features

- Dual Mode IEEE802.11b, IEEE802.11g, IEEE802.11n
- Integrated PA, TX Filter, Diversity switch
- Integrated Positive Slope Power Detector
- 20 dBm Output Power, 802.11b, 11 Mbps
- 17 dBm @ 3.0 % EVM, 802.11g, 3.3V
- Lead free, halogen free and RoHS compliant
- Small plated package, 3 mm x 4 mm x 0.9 mm, MSL 1

Product Description

The SE2564L is a complete 802.11bgn WLAN RF front-end module providing all the functionality of the power amplifier, power detector, diversity switch and 50 ohm matching on all RF ports. The SE2564L provides a complete 2.4 GHz WLAN RF solution from the output of the transceiver to the antennas in an ultra compact form factor.

The SE2564L is designed for ease of use, with all the critical matching and harmonic filtering and integrated transmit/receive DPDT switch providing a 50 Ω interface to the antenna. The SE2564L also includes a transmitter power detector with 20 dB of dynamic range and a digital enable control for transmitter power ramp on/off control. The power ramp rise/fall time is 0.5 μs typical.

Ordering Information

Part No.	Package	Remark
SE2564L	24 pin QFN	Samples
SE2564L-R	24 pin QFN	Tape & Reel
SE2564L-EK1	N/A	Evaluation kit

Functional Block Diagram

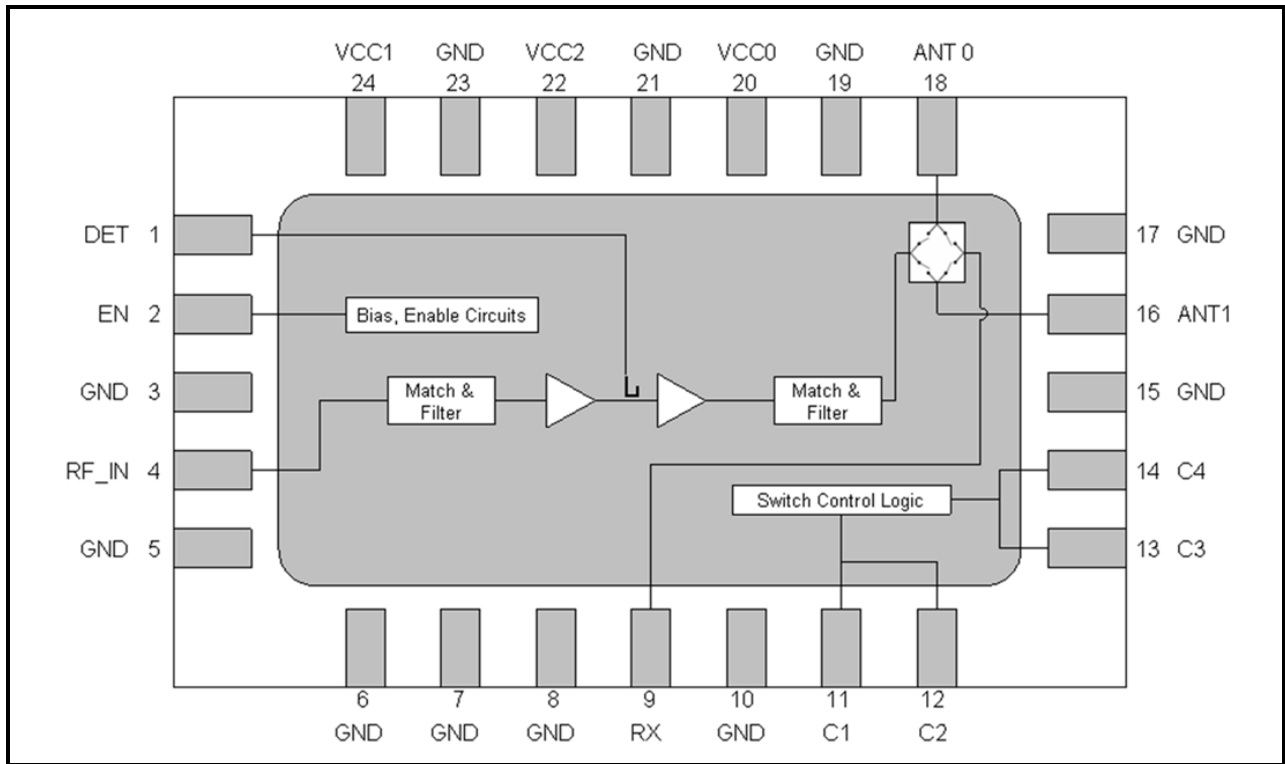

Figure 1: Functional Block Diagram

DATA SHEET
SE2564L: 2.4 GHz High Efficiency Wireless LAN Front-End

Pin Out Diagram

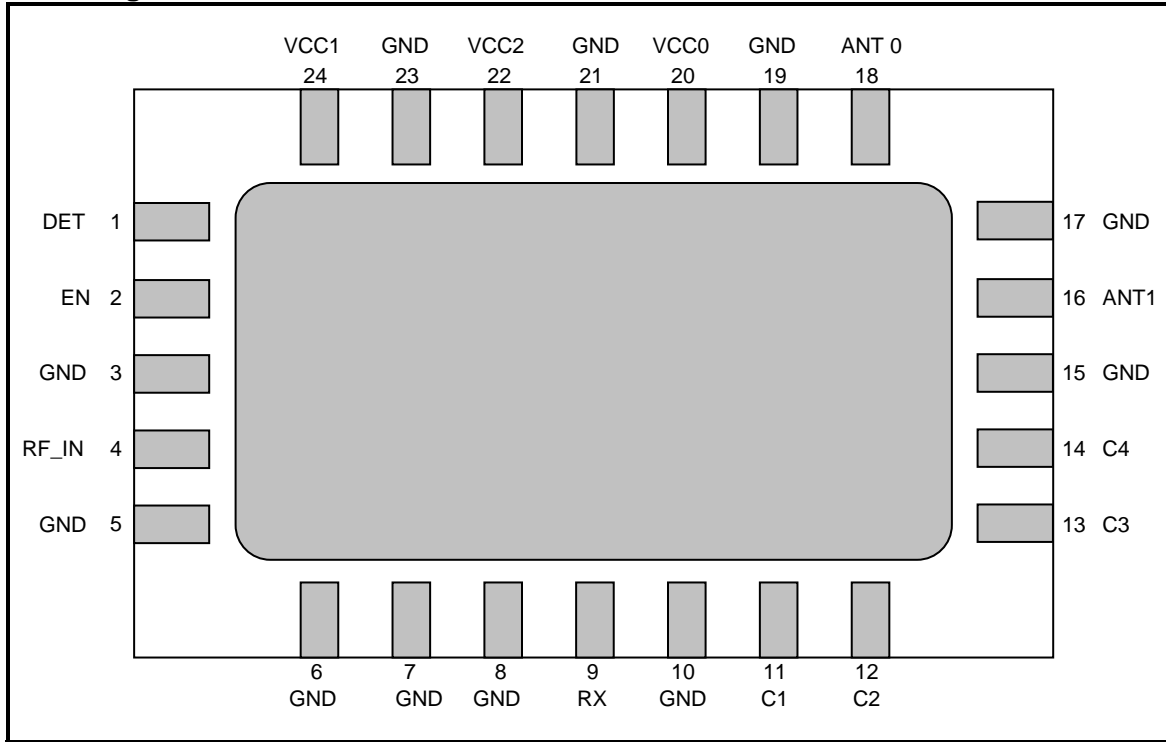

Figure 2: SE2564L Pin Out (Top View Through Package)

Pin Out Description

Pin No.	Name	Description
1	Det	Power Detector Output
2	EN	Power Amplifier Enable
3	GND	Ground
4	RF_IN	Transmit RF Input
5	GND	Ground
6	GND	Ground
7	GND	Ground
8	GND	Ground
9	RX	Receive RF Output
10	GND	Ground
11	C1	Switch Control Logic
12	C2	Switch Control Logic
13	C3	Switch Control Logic

Pin No.	Name	Description
14	C4	Switch Control Logic
15	GND	Ground
16	ANT1	Antenna 1
17	GND	Ground
18	ANT0	Antenna 0
19	GND	Ground
20	VCC0	Supply Voltage
21	GND	Ground
22	VCC2	Supply Voltage
23	GND	Ground
24	VCC1	Supply Voltage
Paddle	GND	Ground

DATA SHEET
SE2564L: 2.4 GHz High Efficiency Wireless LAN Front-End

Absolute Maximum Ratings

These are stress ratings only. Exposure to stresses beyond these maximum ratings may cause permanent damage to, or affect the reliability of the device. Avoid operating the device outside the recommended operating conditions defined below. This device is ESD sensitive. Handling and assembly of this device should be at ESD protected workstations.

Symbol	Definition	Min.	Max.	Unit
VCC	Supply Voltage on VCC	-0.3	5.5	V
V _{IN}	DC input on EN, C1, C2, C3, C4	-0.3	3.6	V
TX	RF Input Power. ANT0 and ANT1 terminated in 50Ω match	-	12.0	dBm
T _A	Operating Temperature Range	-30	85	°C
T _{STG}	Storage Temperature Range	-40	150	°C
ESD _{HBM}	JEDEC JESD22-A114 all pins	-	150	V
ESD _{CDM}	JESD22-C101E all pins	-	300	V

Recommended Operating Conditions

Symbol	Parameter	Min.	Typ.	Max.	Unit
T _A	Ambient temperature	-30	25	85	°C
VCC	VCC1, VCC2 supply voltage	2.9	3.3	5.5	V
	VCC0 supply voltage (may use GPIO)	2.7	-	3.6	V

DC Electrical Characteristics

Conditions: VCC = EN = 3.3 V, T_A = 25 °C, as measured on Skyworks Solutions' SE2564L-EK1 evaluation board (de-embedded to device), all unused ports terminated with 50 ohms, unless otherwise noted

Symbol	Parameter	Conditions	Min.	Typ.	Max.	Unit
I _{CC-G}	Total Supply Current	P _{OUT} = 17 dBm, 54 Mbps OFDM signal, 64QAM	-	130	-	mA
I _{CC-B}	Total Supply Current	P _{OUT} = 19 dBm, 11 Mbps CCK signal, BT = 0.45	-	160	-	mA
I _{CQ}	Total Supply Current	No RF	-	85	-	mA
I _{CNTL}	Control Line Current	C1, C2, C3 or C4 = 3.3V	-	1	10	μA
I _{CC0}	Supply Current on VCC0	No RF, VCC0 = 3.3V	-	70	100	μA
I _{CC-OFF}	Total Supply Current	No RF Applied, EN = R0 = T0 = T1 = R1 = VCC0 = 0 V	-	1	10	μA
		No RF Applied, EN = R0 = T0 = T1 = R1 = 0 V; VCC0 = 3.3V	-	71	110	μA

DATA SHEET
SE2564L: 2.4 GHz High Efficiency Wireless LAN Front-End

PA Logic Characteristics

Conditions: $V_{CC} = EN = 3.3\text{ V}$, $T_A = 25\text{ }^\circ\text{C}$, as measured on Skyworks Solutions' SE2564L-EK1 evaluation board (de-embedded to device), all unused ports terminated with 50 ohms, unless otherwise noted.

Symbol	Parameter	Conditions	Min.	Typ.	Max.	Unit
V_{ENH}	Logic High Voltage (Module On)	-	1.8	3.3	3.6	V
V_{ENL}	Logic Low Voltage (Module Off)	-	0	-	0.4	V
I_{ENH}	Input Current Logic High Voltage	-	-	2	10	μA
I_{ENL}	Input Current Logic Low Voltage	-	-	2	10	μA

Switch Logic Characteristics

Conditions: $V_{CC} = EN = 3.3\text{ V}$, $T_A = 25\text{ }^\circ\text{C}$, as measured on Skyworks Solutions' SE2564L-EK1 evaluation board (de-embedded to device), all unused ports terminated with 50 ohms, unless otherwise noted.

Symbol	Parameter	Conditions	Min.	Typ.	Max.	Unit
V_{CTL_ON}	Control Voltage (On State)	-	3.0	-	3.6	V
V_{CTL_OFF}	Control Voltage (OFF State)	-	0.0	-	0.2	V
ON	Low Loss Switch Control Voltage	High State = $V_{CTL_ON} - V_{CTL_OFF}$	2.7	-	3.6	V
OFF	High Loss Switch Control Voltage	Low State = $V_{CTL_OFF} - V_{CTL_OFF}$	0	-	0.3	V
C_{CTL}	Control Input Capacitance	-	-	-	100	pF



DATA SHEET
SE2564L: 2.4 GHz High Efficiency Wireless LAN Front-End

Switch Control Logic Table

Switch Logic				Operational Mode			
C1	C2	C3	C4	TX – ANT0	TX – ANT1	RX – ANT0	RX – ANT1
ON	ON	ON	ON	ON	OFF	OFF	OFF
OFF	ON	ON	ON	OFF	OFF	ON	OFF
ON	ON	ON	OFF	OFF	ON	OFF	OFF
OFF	ON	ON	OFF	OFF	OFF	OFF	ON
ON	OFF	OFF	OFF	ON	OFF	OFF	OFF
OFF	ON	OFF	OFF	OFF	OFF	OFF	ON
OFF	OFF	ON	OFF	OFF	ON	OFF	OFF
OFF	OFF	OFF	ON	OFF	OFF	ON	OFF
ON	ON	OFF	OFF	ON	OFF	OFF	ON
OFF	OFF	ON	ON	OFF	ON	ON	OFF
All other configurations				All switches set to OFF			



DATA SHEET
SE2564L: 2.4 GHz High Efficiency Wireless LAN Front-End

AC Electrical Characteristics

802.11g/n Transmit Characteristics

Conditions: VCC = EN = 3.3 V, TA = 25 °C, as measured on Skyworks Solutions' SE2564L-EK1 evaluation board (de-embedded to device), all unused ports terminated with 50 ohms, unless otherwise noted.

Symbol	Parameter	Condition	Min.	Typ.	Max.	Unit
F _{IN}	Frequency Range	-	2400	-	2500	MHz
P _{OUT}	Output Power	54 Mbps OFDM signal, 64 QAM, 3% Static EVM	-	17	-	dBm
		3% Dynamic EVM	-	17	-	
ACPR, IEEE Mask	Spectral Mask	P _{OUT} = 20 dBm, 11 Mbps CCK, BT = 0.45 11 – 22 MHz 22 – 33 MHz	-	-35 -55	-	dBc
P _{1dB}	P1dB	-	-	23.0	-	dBm
S ₂₁	Small Signal Gain	-	24	27	30	dB
ΔS ₂₁	Small Signal Gain Variation	Gain variation over single 40MHz channel Gain Variation over band	-	0.5	1.0	dB
S _{213.2}	Gain @ limit at Ref-vco spur frequency	3206 to 3312 MHz	-	-	15	dB
2f	Harmonics	P _{OUT} = 19 dBm, 1 Mbps, CCK	-	-50	-45	dBm/MHz
3f			-	-50	-45	dBm/MHz
t _{dr} , t _{df}	Delay and rise/fall Time	50 % of V _{EN} edge and 90/10 % of final output power level	-	0.7	-	μs
S ₁₁	Input Return Loss	-	10	14	-	dB
STAB	Stability	CW, P _{OUT} = 20 dBm 0.1 GHz – 20 GHz Load VSWR = 6:1	All non-harmonically related outputs less than -42 dBm/MHz			
RU	Ruggedness	P _{IN} = 12dBm, Load VSWR = 6:1	No permanent damage			

DATA SHEET
SE2564L: 2.4 GHz High Efficiency Wireless LAN Front-End

Receive Characteristics

Conditions: VCC = 3.3 V, EN = 0 V, TA = 25 °C, as measured on Skyworks Solutions' SE2564L-EK1 evaluation board (de-embedded to device), all unused ports terminated with 50 ohms, unless otherwise noted.

Symbol	Parameter	Condition	Min.	Typ.	Max.	Unit
F _{OUT}	Frequency Range	-	2400	-	2500	MHz
R _{XIL}	Insertion Loss	-	-	0.9	1.2	dB
R _{XRL}	Return Loss	-	10	15	-	dB
Delta Rx	Delta between Rx paths	ANT0 to RX or ANT1 to RX	-	-	0.5	dB
T _{on/off}	T/R on/off switching speed	Switching speed between T/R modes. V _{CC0} =3.3V.	-	100	250	nSec
T _{RISO}	Tx to Rx Leakage	Device transmitting (EN = 3.3 V) with 17.0 dBm. @ ANT0 or ANT1. Power measured @ RX TX ↔ ANT0 or ANT1 = ON, RX ↔ ANT0 or ANT1 = OFF	-	-3	0	dBm
ANTR _{ISOL}	Isolation between ANT0 and ANT1	Difference in transmitted signal level on ANT1 or ANT0 while transmitting from ANT0 or ANT1. TX ↔ ANT0 or ANT1 = ON, Rx and opposite ANT port terminated in 50ohm.	18	25	-	dB

DATA SHEET
SE2564L: 2.4 GHz High Efficiency Wireless LAN Front-End

Power Detector Characteristics

Conditions: $V_{CC} = EN = 3.3\text{ V}$, $T_A = 25\text{ }^\circ\text{C}$, as measured on Skyworks Solutions' SE2564L-EK1 evaluation board, unless otherwise noted.

Symbol	Parameter	Condition	Min.	Typ.	Max.	Unit
F _{OUT}	Frequency Range	-	2400	-	2500	MHz
PDR	Power detect range, CW	Measured at ANT0 or ANT1	0	-	21	dBm
PDZ _{src}	DC source impedance on PD_OUT	-	-	1	-	kΩ
PDV _{NoRF}	Output Voltage, P _{OUT} = No RF	Measured into 1MΩ	-	0.12	-	V
PDV _{p18}	Output Voltage, P _{OUT} = 17 dBm CW	Measured into 1MΩ	-	0.45	-	V
PDV _{p21}	Output Voltage, P _{OUT} = 21 dBm CW	Measured into 1MΩ	-	0.75	-	V
LPF _{-3dB}	Power detect low pass filter -3dB corner frequency	PDC _{LOAD} = 390 pF	270	290	400	kHz

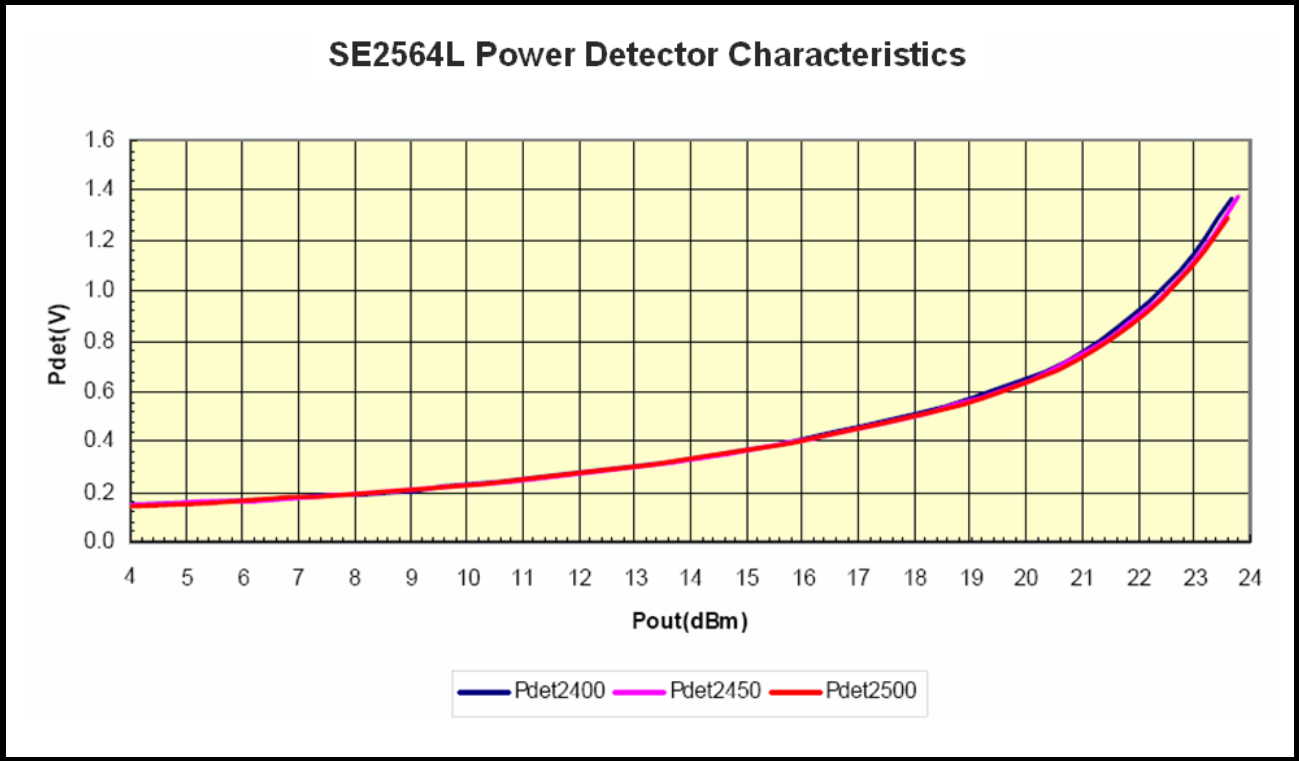

DATA SHEET
SE2564L: 2.4 GHz High Efficiency Wireless LAN Front-End

Package Diagram

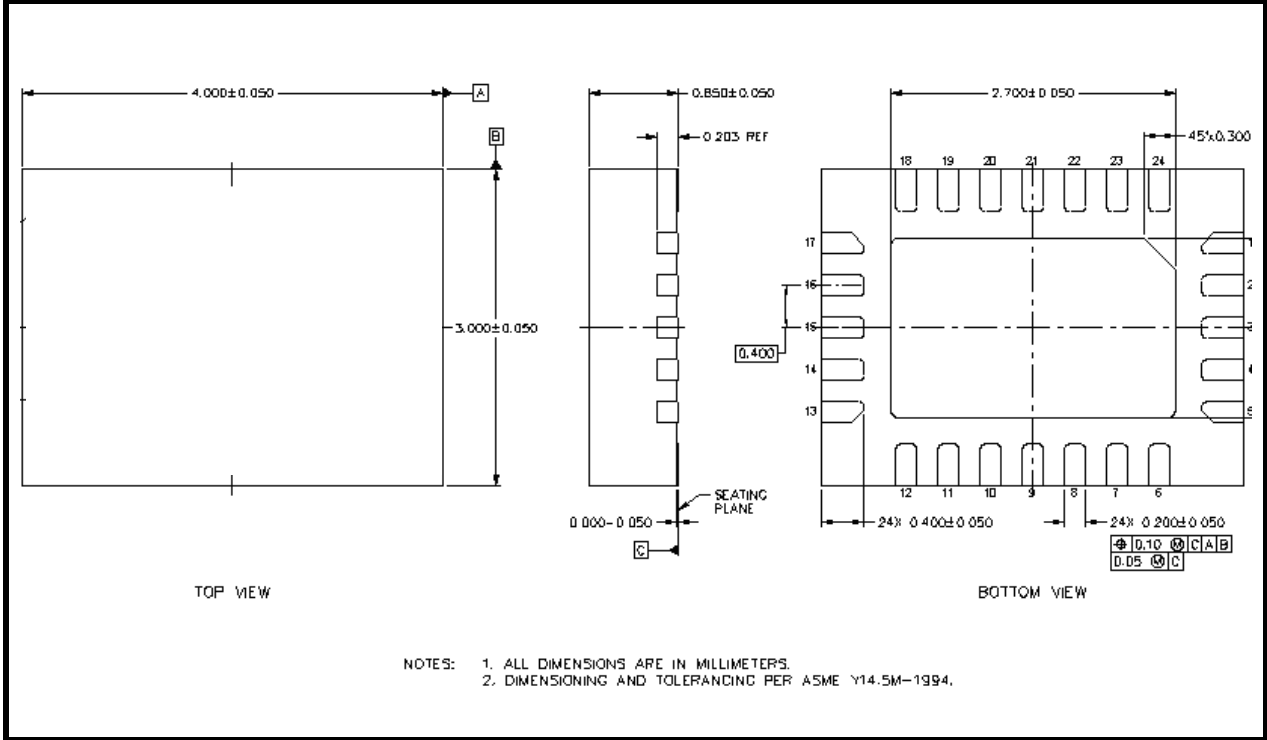

Figure 4: SE2564L Package Outline Drawing

Recommended Land and Solder Patterns

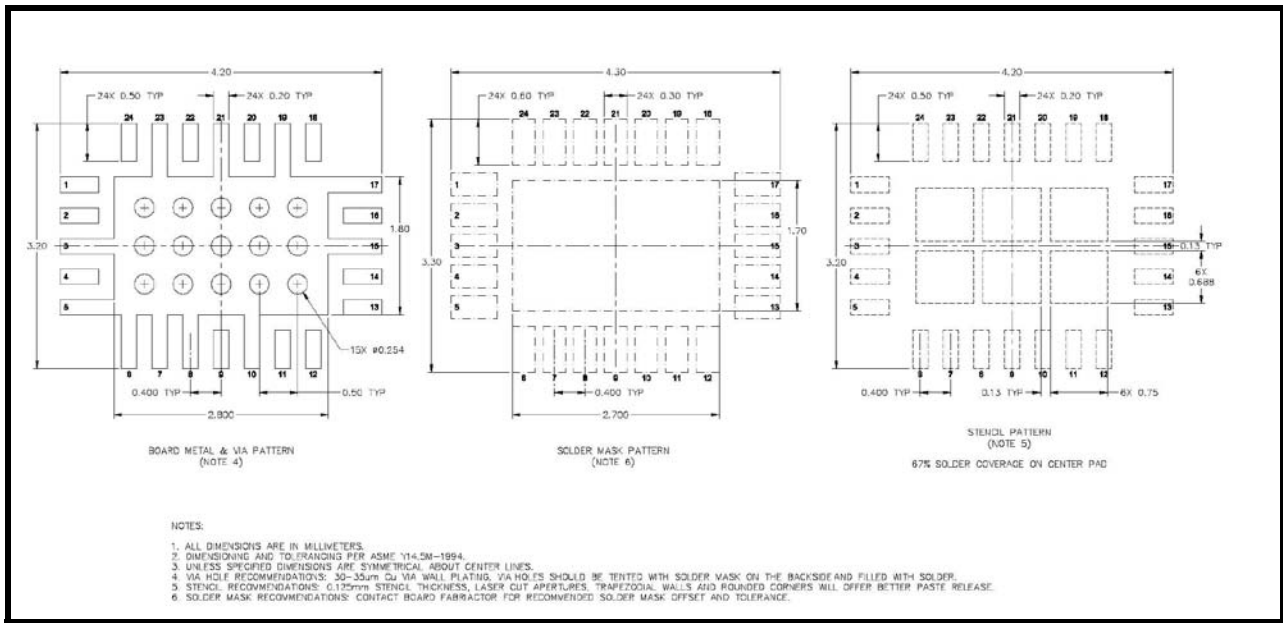

Figure 5: Recommended Land and Solder Patterns



DATA SHEET

SE2564L: 2.4 GHz High Efficiency Wireless LAN Front-End

Package Handling Information

Because of its sensitivity to moisture absorption, instructions on the shipping container label must be followed regarding exposure to moisture after the container seal is broken, otherwise, problems related to moisture absorption may occur when the part is subjected to high temperature during solder assembly. The SE2564L is capable of withstanding a Pb free solder reflow. Care must be taken when attaching this product, whether it is done manually or in a production solder reflow environment. If the part is manually attached, precaution should be taken to insure that the device is not subjected to temperatures above its rated peak temperature for an extended period of time. For details on both attachment techniques, precautions, and handling procedures recommended, please refer to:

- “Quad Flat No-Lead Module Solder Reflow & Rework Information”, *Document Number QAD-00045*
- “Handling, Packing, Shipping and Use of Moisture Sensitive QFN”, *Document Number QAD-00044*
- “ESD Control Policy”, *Document Number SQ03-0062*



Caution! Class 0 ESD sensitive device

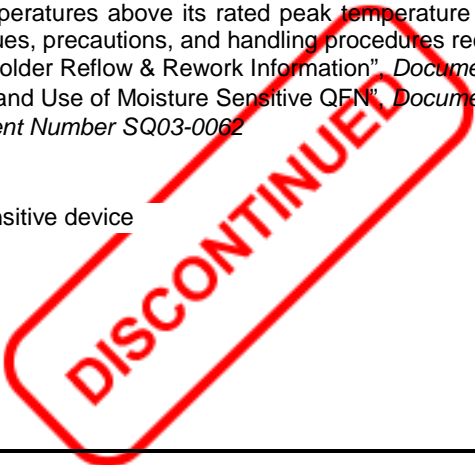

Branding Information

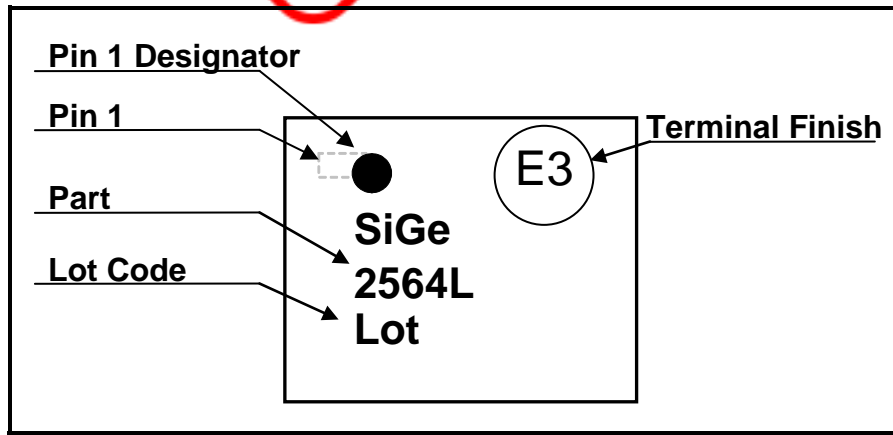

Figure 6: SE2564L Branding and Pin 1 Location

DATA SHEET
SE2564L: 2.4 GHz High Efficiency Wireless LAN Front-End

Tape and Reel Information

Parameter	Value
Devices Per Reel	3000
Reel Diameter	13 inches
Tape Width	12 millimeters

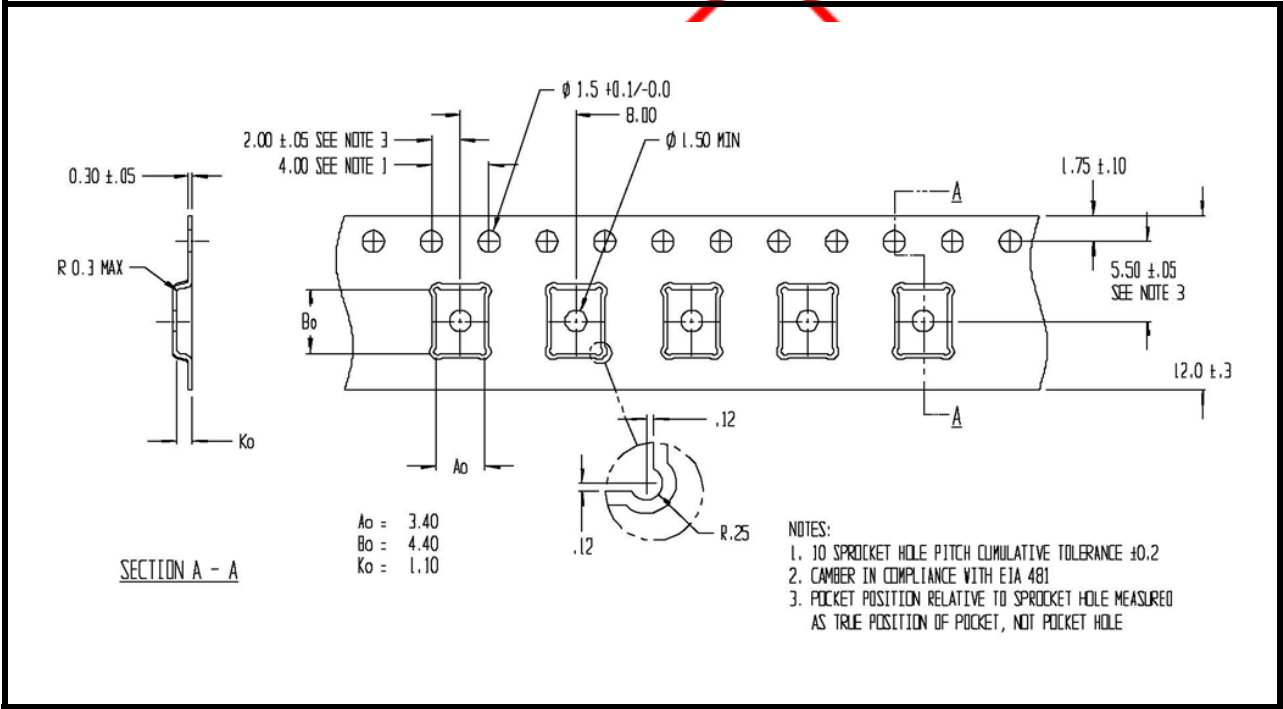

Figure 7: SE2564L-R Tape and Reel Information

DATA SHEET
SE2564L: 2.4 GHz High Efficiency Wireless LAN Front-End

Document Change History

Revision	Date	Notes
1.0	Jun 19, 2009	Created
1.1	Jul 8, 2009	Added ISO label
1.2	Aug 18, 2009	Added Solder and Land Pattern
1.3	Sep 4, 2009	Updated Total Leakage Current in OFF state Corrected Pinout Definition
1.4	Sep 18, 2009	Add Tape and Reel information
1.5	Sep 23, 2009	Add Dynamic EVM specification
1.6	Sep 29, 2009	Removed reference to pull down resistor, updated leakage current
1.7	Jan 21, 2010	Added ESD warning
1.8	Jan 29, 2010	Removed reference to incorrect part number
1.9	Jun 9, 2010	Updated MSL rating from MSL 3 to MSL 1
2.0	Nov 19, 2010	Updated recommended operating temperature range
2.1	Mar 7, 2012	Remove "Preliminary" from datasheet status.
2.2	Apr 10, 2012	Updated with Skyworks logo and disclaimer statement

Copyright © 2012 Skyworks Solutions, Inc. All Rights Reserved.

Information in this document is provided in connection with Skyworks Solutions, Inc. ("Skyworks") products or services. These materials, including the information contained herein, are provided by Skyworks as a service to its customers and may be used for informational purposes only by the customer. Skyworks assumes no responsibility for errors or omissions in these materials or the information contained herein. Skyworks may change its documentation, products, services, specifications or product descriptions at any time, without notice. Skyworks makes no commitment to update the materials or information and shall have no responsibility whatsoever for conflicts, incompatibilities, or other difficulties arising from any future changes.

No license, whether express, implied, by estoppel or otherwise, is granted to any intellectual property rights by this document. Skyworks assumes no liability for any materials, products or information provided hereunder, including the sale, distribution, reproduction or use of Skyworks products, information or materials, except as may be provided in Skyworks Terms and Conditions of Sale.

THE MATERIALS, PRODUCTS AND INFORMATION ARE PROVIDED "AS IS" WITHOUT WARRANTY OF ANY KIND, WHETHER EXPRESS, IMPLIED, STATUTORY, OR OTHERWISE, INCLUDING FITNESS FOR A PARTICULAR PURPOSE OR USE, MERCHANTABILITY, PERFORMANCE, QUALITY OR NON-INFRINGEMENT OF ANY INTELLECTUAL PROPERTY RIGHT; ALL SUCH WARRANTIES ARE HEREBY EXPRESSLY DISCLAIMED. SKYWORKS DOES NOT WARRANT THE ACCURACY OR COMPLETENESS OF THE INFORMATION, TEXT, GRAPHICS OR OTHER ITEMS CONTAINED WITHIN THESE MATERIALS. SKYWORKS SHALL NOT BE LIABLE FOR ANY DAMAGES, INCLUDING BUT NOT LIMITED TO ANY SPECIAL, INDIRECT, INCIDENTAL, STATUTORY, OR CONSEQUENTIAL DAMAGES, INCLUDING WITHOUT LIMITATION, LOST REVENUES OR LOST PROFITS THAT MAY RESULT FROM THE USE OF THE MATERIALS OR INFORMATION, WHETHER OR NOT THE RECIPIENT OF MATERIALS HAS BEEN ADVISED OF THE POSSIBILITY OF SUCH DAMAGE.

Skyworks products are not intended for use in medical, lifesaving or life-sustaining applications, or other equipment in which the failure of the Skyworks products could lead to personal injury, death, physical or environmental damage. Skyworks customers using or selling Skyworks products for use in such applications do so at their own risk and agree to fully indemnify Skyworks for any damages resulting from such improper use or sale.

Customers are responsible for their products and applications using Skyworks products, which may deviate from published specifications as a result of design defects, errors, or operation of products outside of published parameters or design specifications. Customers should include design and operating safeguards to minimize these and other risks. Skyworks assumes no liability for applications assistance, customer product design, or damage to any equipment resulting from the use of Skyworks products outside of stated published specifications or parameters.

Skyworks, the Skyworks symbol, and "Breakthrough Simplicity" are trademarks or registered trademarks of Skyworks Solutions, Inc., in the United States and other countries. Third-party brands and names are for identification purposes only, and are the property of their respective owners. Additional information, including relevant terms and conditions, posted at www.skyworksinc.com, are incorporated by reference.

X-ON Electronics

Largest Supplier of Electrical and Electronic Components

Click to view similar products for [RF Front End](#) category:

Click to view products by [Skyworks](#) manufacturer:

Other Similar products are found below :

[SE2622L-R](#) [BGM1032N7E6327XUSA1](#) [LX5586LL](#) [SKY85703-11](#) [LX5586HLL](#) [LX5586ALL](#) [SKY66111-21](#) [SKY65728-11](#) [SKY68000-31](#)
[SKY85308-11](#) [SKY85302-11](#) [SKY65724-11](#) [ADTR1107ACCZ](#) [LMP91051MTX/NOPB](#) [SE5501L-R](#) [QPF4519SR](#) [SE5503A-R](#)
[ADA8282WBCPZ](#) [ADRF5545ABCPZN](#) [ADRF5545ABCPZN-R7](#) [AD8283WBCPZ](#) [AD8284WCSVZ](#) [ADRF5547BCPZN](#)
[ADRF5547BCPZN-R7](#) [ADRF5549BCPZN](#) [ADRF5549BCPZN-R7](#) [HV7350K6-G](#) [SE5516A-R](#) [MCP2030-I/SL](#) [MAX2009ETI+](#)
[MAX2078CTK+](#) [MAX2335ETI+](#) [MAX2678GTB/V+T](#) [MD2131K7-G](#) [MD2134K7-G](#) [RFFM6903TR13](#) [HV7351K6-G](#) [MCP2035-I/ST](#)
[SE2614BT-R](#) [SE2438T-R](#) [SST12LF02-QXCE](#) [SST12LF09-Q3CE](#) [RFX2401C](#) [RFX2402E](#) [SKY85201-11](#) [RFFM4591FTR7](#) [RFFM8211TR7](#)
[RFFM4293TR7](#) [RFFM4203TR7](#) [RFFM5765QTR7](#)