

DATA SHEET
SE2567L: 5 GHz Power Amplifier with Power Detector
Preliminary Information

Applications

- DSSS 5 GHz WLAN (IEEE802.11a)
- Access Points, PCMCIA, PC cards

Features

- High output power amplifier 19dBm
- Integrated 50ohm input and output match
- Integrated power amplifier enable pin (VEN)
- Buffered, temperature compensated power detector
- 3% EVM, @19dBm, 64 QAM, 54 Mbps
- 30 dB Gain
- Lead Free and RoHS compliant, halogen free package
- 16 pin 3 mm x 3 mm x 0.9 mm QFN

Product Description

The SE2567L is a 5GHz power amplifier offering high linear power for wireless LAN applications. It incorporates a power detector for closed loop monitoring and control of the output power.

The SE2567L offers a high level of integration for a simplified design, providing quicker time to market and higher application board production yield. The device integrates the input match, the inter-stage match, a temperature compensated, load insensitive power detector with 15dB of dynamic range and a 3.8GHz notch filter. Two external components are required to complete the design.

For wireless LAN applications, the device meets the requirements of IEEE802.11a and delivers approximately 19dBm of linear output power.

The SE2567L integrates the reference voltage generator, allowing for a true CMOS compatible digital EN (enable) function to turn the power amplifier on and off.

Ordering Information

Part Number	Package	Remark
SE2567L	16 Pin QFN	Samples
SE2567L-R	16 Pin QFN	Tape and Reel
SE2567L-EK1	Evaluation Kit	Standard

Functional Block Diagram

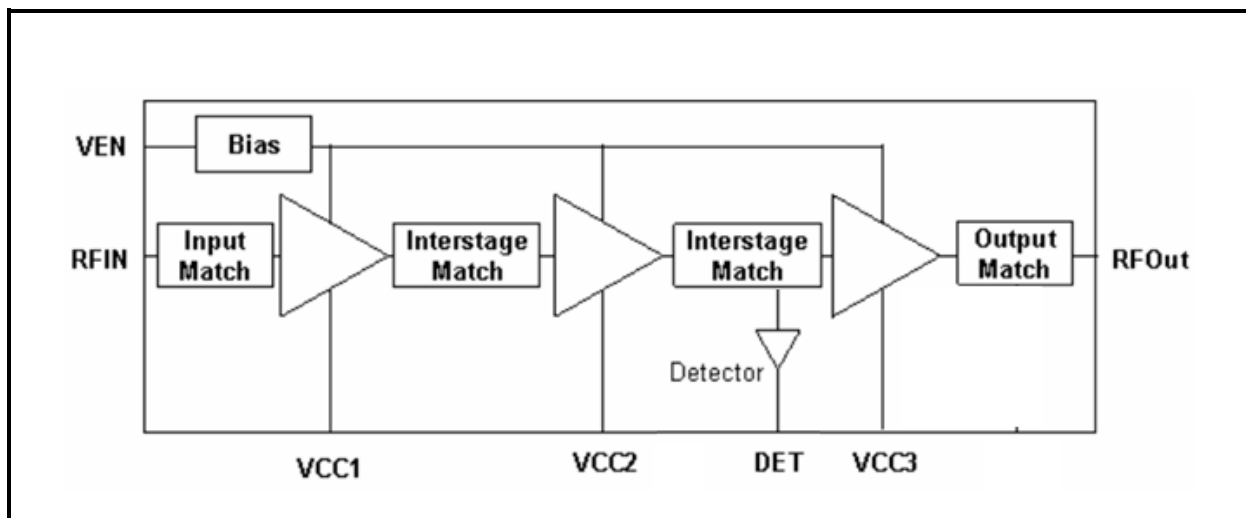

Figure 1: Functional Block Diagram

DATA SHEET
SE2567L: 5 GHz Power Amplifier with Power Detector
Preliminary Information

Pin Out Diagram

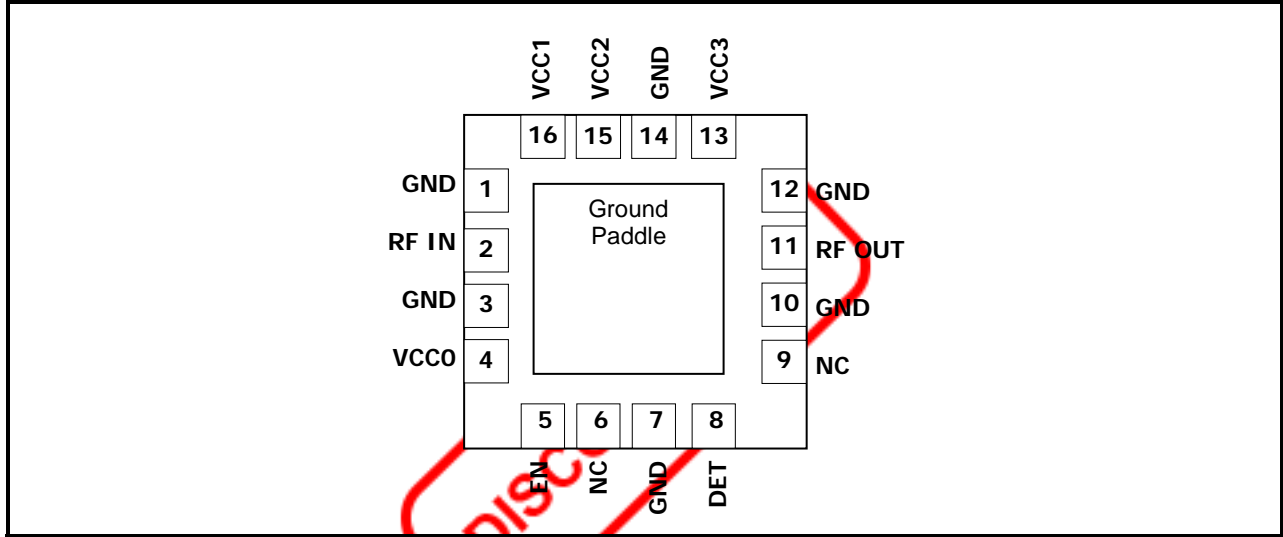

Figure 2: SE2567L Pin-Out Diagram

Pin Out Description

Pin No.	Name	Description
1	GND	Ground
2	RFin	Power Amplifier RF input, DC block required
3	GND	Ground
4	VCC0	Bias Circuit Supply Voltage
5	EN	Reference Voltage and Power Amplifier Enable
6	NC	No Connect
7	GND	Ground
8	DET	Analog Power Detector Output
9	NC	No Connect
10	GND	Ground
11	RFout	Power Amplifier RF Output, no DC block required
12	GND	Ground
13	VCC3	Third Stage Supply Voltage
14	GND	Ground
15	VCC2	Second Stage Supply Voltage
16	VCC1	First Stage Supply Voltage

DATA SHEET
SE2567L: 5 GHz Power Amplifier with Power Detector
Preliminary Information

Absolute Maximum Ratings

These are stress ratings only. Exposure to stresses beyond these maximum ratings for a long period of time may cause permanent damage to, or affect the reliability of the device. Avoid operating the device outside the recommended operating conditions defined below. This device is ESD sensitive. Handling and assembly of this device should be at ESD protected workstations.

Symbol	Definition	Min.	Max.	Unit
V _{CC}	Supply Voltage on pins VCC0, VCC1	-0.3	3.6	V
	Supply Voltage on pins VCC2, VCC3	-0.3	4.9	
EN	DC input on EN	-0.3	3.6	V
R _{FIN}	RF Input Power, R _{Fout} into 50Ω match	-	12	dBm
T _{STG}	Storage Temperature Range	-40	150	°C
ESD _{HBM}	JEDEC JESD22-A114 all pins	-	500	V

Recommended Operating Conditions

Symbol	Parameter	Min.	Max.	Unit
V _{CC}	Supply Voltage (VCC0, VCC1)	3.0	3.6	V
	Supply Voltage (VCC2, VCC3)	3.0	4.5	
T _A	Ambient Temperature	-40	85	°C

DC Electrical Characteristics

Conditions: V_{CC} = V_{EN} = 3.3 V, T_A = 25 °C, as measured on Skyworks Solutions' SE2567L-EV1 evaluation board, unless otherwise noted.

Symbol	Parameter	Conditions	Min.	Typ.	Max.	Unit
I _{CC-802.11a}	Supply Current	P _{OUT} = 19 dBm, 54 Mbps, 64 QAM	-	220	-	mA
I _{QC}	Quiescent Current	No RF	-	150	-	mA
I _{OFF}	Supply Current	V _{EN} = 0 V, No RF	-	10	100	μA
V _{ENH}	Logic High Voltage	-	1.6	-	3.6	V
V _{ENL}	Logic Low Voltage	-	0	-	0.5	V
I _{ENH}	Input Current Logic High Voltage	-	-	300	-	μA
I _{ENL}	Input Current Logic Low Voltage	-	-	<1	-	μA
Z _{EN}	Enable pin input impedance	Passive Pull Down		10		kΩ

DATA SHEET
SE2567L: 5 GHz Power Amplifier with Power Detector
Preliminary Information

AC Electrical Characteristics

802.11a AC Electrical Characteristics

Conditions: $V_{CC} = V_{EN} = 3.3V$, $f = 5.4$ GHz, $T_A = 25$ °C, as measured on Skyworks Solutions' SE2567L-EV1 evaluation board, unless otherwise noted

Symbol	Parameter	Conditions	Min.	Typ.	Max.	Unit
f _{L-U}	Frequency Range	-	4.9	-	5.9	GHz
P _{OUT}	Output Power, 54 Mbps OFDM signal, 64 QAM, 3% EVM	VCC0,1,2,3 = 3.3V	-	19	-	dBm
		VCC0,1 = 3.3V; VCC2,3 = 4.5V	-	21.5	-	
P _{1dB}	Output 1dB compression point	No modulation	-	25	-	dBm
S ₁₁	Input Return Loss	P _{IN} = -25 dBm	6	-	-	dB
S ₂₁	Small Signal Gain	P _{IN} = -25 dBm	-	30	-	dB
ΔS ₂₁	Small Signal Gain Variation	Gain variation over single 40MHz channel	-	0.5	-	dB
		Gain Variation over band	-	2.0	4.0	
S _{21_3.8}	Out of Band Gain	Gain at 3.8GHz	-	-	10	dB
2f	Harmonic	P _{OUT} = 19.0dBm @3.3V or P _{OUT} = 21.5dBm @4.5V	-	-50	-	dBm/MHz
3f			-	-50	-	dBm/MHz
t _r , t _f	Rise and Fall Time	-	-	0.5	-	us
STAB	Stability	P _{OUT} = 19 dBm, 54 Mbps, 64 QAM, VSWR = 6:1, all phases	All non-harmonically related outputs less than -50 dBc/100 kHz			
RU	Ruggedness: Tolerance to output load mismatching	P _{IN} = 12 dBm, VCC2 = VCC3 = 4.5V, 54 Mbps 64 QAM, 64 QAM, VSWR = 6:1, all phases	No damage			

DATA SHEET
SE2567L: 5 GHz Power Amplifier with Power Detector
Preliminary Information

Power Detector

Conditions: $V_{CC} = V_{EN} = 3.3V$, $f = 5.4 \text{ GHz}$, $T_A = 25 \text{ }^\circ\text{C}$, as measured on Skyworks Solutions' SE2567L-EV1 evaluation board, unless otherwise noted

Symbol	Parameter	Conditions	Min.	Typ.	Max.	Unit
PDR	P _{OUT} detect range	-	0	-	P _{1dB}	dBm
VDET	Detector voltage, P _{OUT} = 20dBm	Measured into 26.5KΩ	-	1.00	-	V
VDET	Detector voltage, P _{OUT} = 5dBm	Measured into 26.5KΩ	-	0.33	-	V
PDZ _{OUT}	Output Impedance	-	-	2.5	-	KΩ
PDZ _{LOAD}	DC load impedance	-	-	26.5	-	KΩ
LPF	Power detector low pass filter - 3dB corner frequency	Measured into 26.5KΩ	-	2.0	-	MHz

Figure 3: SE2567L Power Detector Characteristic

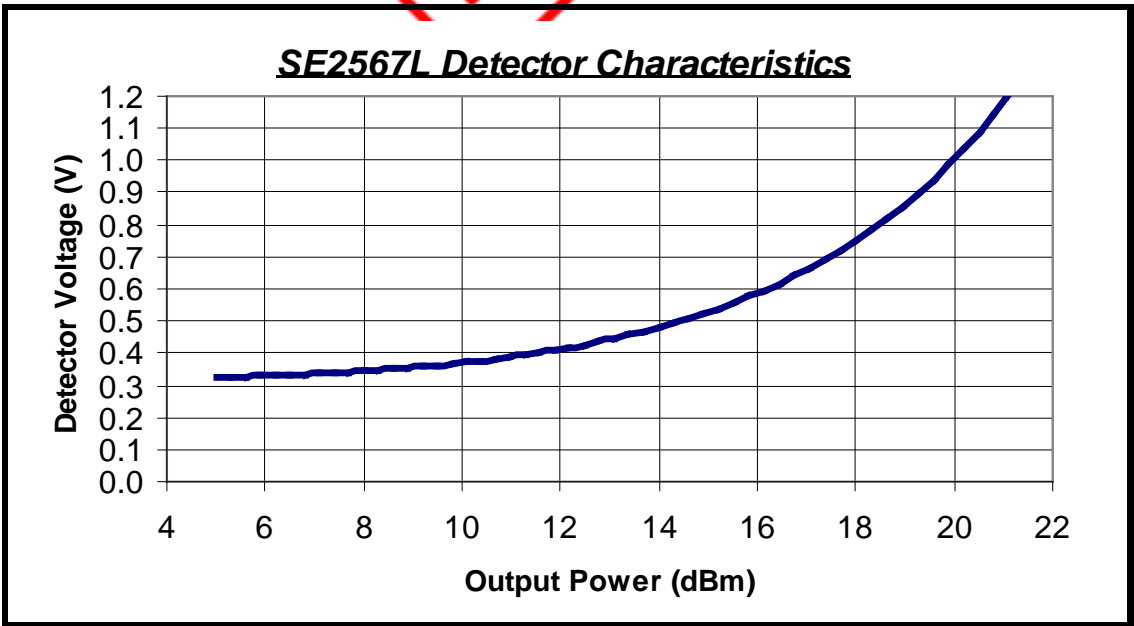



SKYWORKS®

DATA SHEET
SE2567L: 5 GHz Power Amplifier with Power Detector
Preliminary Information

Package Diagram

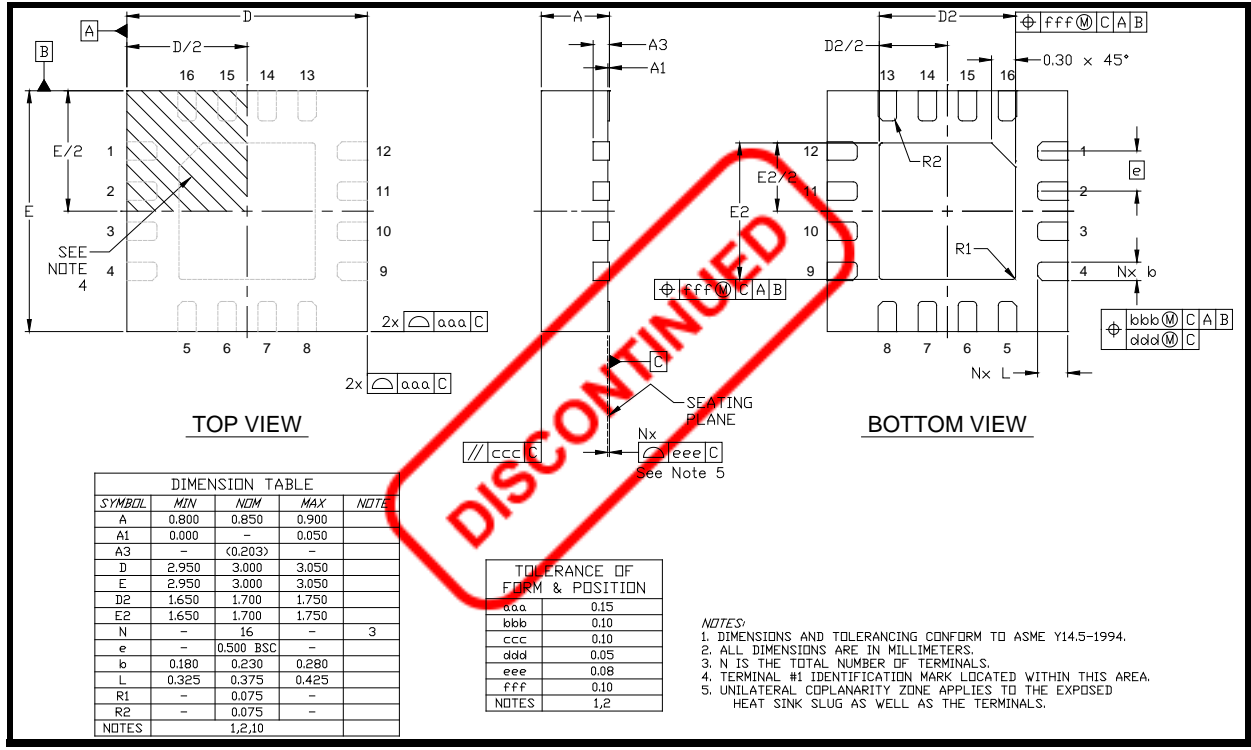

Figure 4: SE2567L Package Diagram

DATA SHEET
SE2567L: 5 GHz Power Amplifier with Power Detector
Preliminary Information

Recommended Land and Solder Patterns

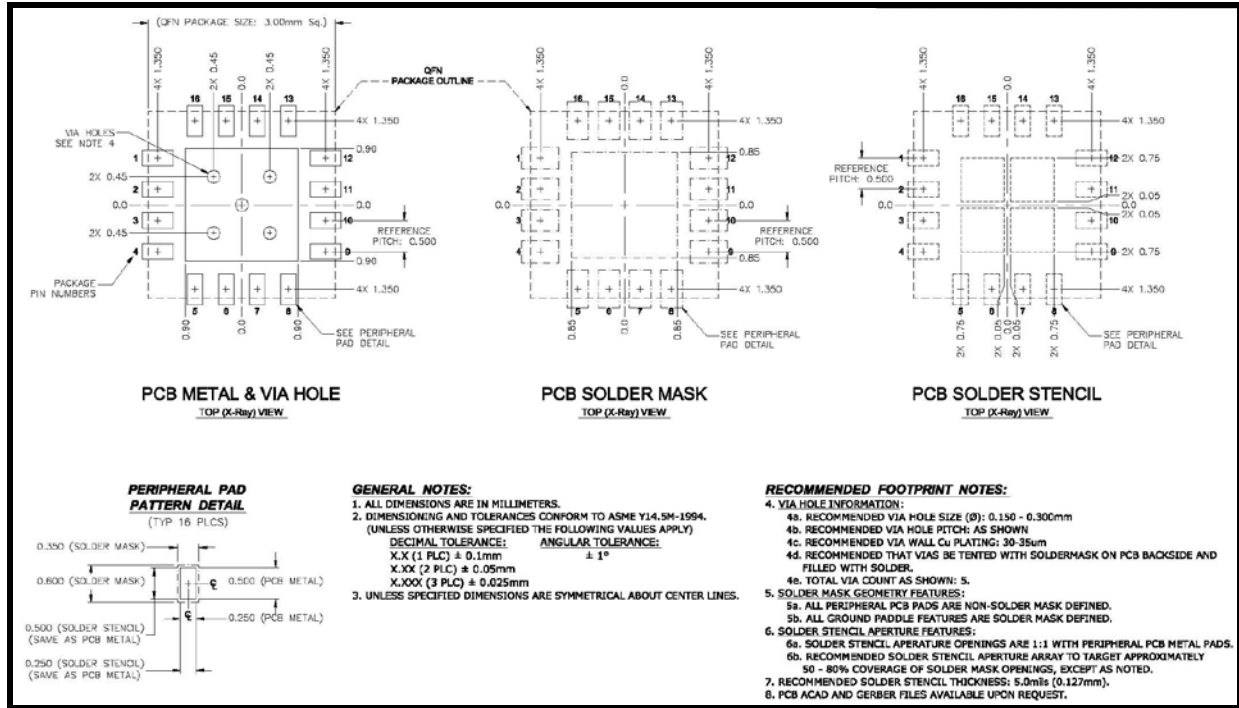
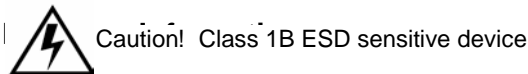

Figure 5: SE2567L Recommended Land and Solder Pattern

Package Handling Information

Because of its sensitivity to moisture absorption, instructions on the shipping container label must be followed regarding exposure to moisture after the container seal is broken, otherwise, problems related to moisture absorption may occur when the part is subjected to high temperature during solder assembly. The SE2597L is capable of withstanding a Pb free solder reflow. Care must be taken when attaching this product, whether it is done manually or in a production solder reflow environment. If the part is manually attached, precaution should be taken to ensure that the device is not subjected to temperatures above its rated peak temperature for an extended period of time. For details on both attachment techniques, precautions, and handling procedures recommended, please refer to:

- “Quad Flat No-Lead Module Solder Reflow & Rework Information”, *Document Number QAD-00045*
- “Handling, Packing, Shipping and Use of Moisture Sensitive QFN”, *Document Number QAD-00044*



DATA SHEET
SE2567L: 5 GHz Power Amplifier with Power Detector
Preliminary Information

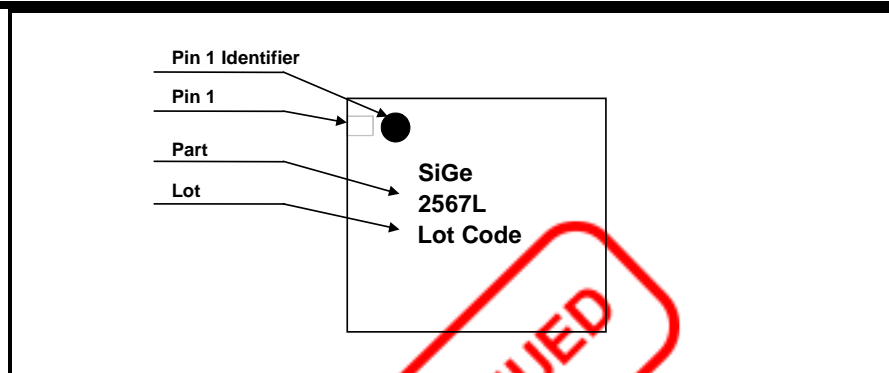

Figure 4: SE2567L Branding

Tape and Reel Information

Parameter	Value
Devices Per Reel	3000
Reel Diameter	13 inches
Tape Width	12 millimeters

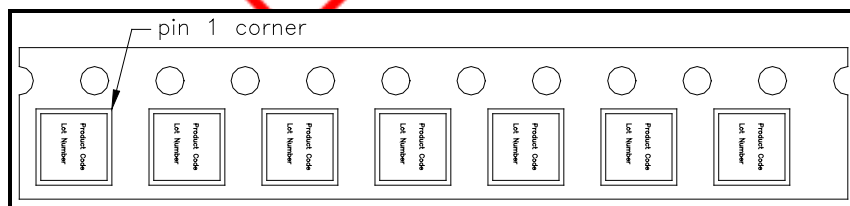
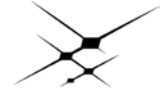

Figure 5: SE2567L-R Tape and Reel Information

Document Change History

Revision	Date	Notes
1.0	August 2, 2009	Created
1.1	February 3, 2010	Updated off-state leakage current. Added reference to "Class 0 ESD Device Handling"
1.2	March 30, 2010	Updated to include 4.5V operation
1.3	November 15, 2010	Updated Ruggedness Specification Updated Recommended Operating Temperature Updated ESD rating Updated marking diagram to remove terminal finish indicator
1.4	April 10, 2012	Updated with Skyworks logo and disclaimer statement



SKYWORKS®

DATA SHEET

SE2567L: 5 GHz Power Amplifier with Power Detector Preliminary Information



Copyright © 2012 Skyworks Solutions, Inc. All Rights Reserved.

Information in this document is provided in connection with Skyworks Solutions, Inc. ("Skyworks") products or services. These materials, including the information contained herein, are provided by Skyworks as a service to its customers and may be used for informational purposes only by the customer. Skyworks assumes no responsibility for errors or omissions in these materials or the information contained herein. Skyworks may change its documentation, products, services, specifications or product descriptions at any time, without notice. Skyworks makes no commitment to update the materials or information and shall have no responsibility whatsoever for conflicts, incompatibilities, or other difficulties arising from any future changes.

No license, whether express, implied, by estoppel or otherwise, is granted to any intellectual property rights by this document. Skyworks assumes no liability for any materials, products or information provided hereunder, including the sale, distribution, reproduction or use of Skyworks products, information or materials, except as may be provided in Skyworks Terms and Conditions of Sale.

THE MATERIALS, PRODUCTS AND INFORMATION ARE PROVIDED "AS IS" WITHOUT WARRANTY OF ANY KIND, WHETHER EXPRESS, IMPLIED, STATUTORY, OR OTHERWISE, INCLUDING FITNESS FOR A PARTICULAR PURPOSE OR USE, MERCHANTABILITY, PERFORMANCE, QUALITY OR NON-INFRINGEMENT OF ANY INTELLECTUAL PROPERTY RIGHT; ALL SUCH WARRANTIES ARE HEREBY EXPRESSLY DISCLAIMED. SKYWORKS DOES NOT WARRANT THE ACCURACY OR COMPLETENESS OF THE INFORMATION, TEXT, GRAPHICS OR OTHER ITEMS CONTAINED WITHIN THESE MATERIALS. SKYWORKS SHALL NOT BE LIABLE FOR ANY DAMAGES, INCLUDING BUT NOT LIMITED TO ANY SPECIAL, INDIRECT, INCIDENTAL, STATUTORY, OR CONSEQUENTIAL DAMAGES, INCLUDING WITHOUT LIMITATION, LOST REVENUES OR LOST PROFITS THAT MAY RESULT FROM THE USE OF THE MATERIALS OR INFORMATION, WHETHER OR NOT THE RECIPIENT OF MATERIALS HAS BEEN ADVISED OF THE POSSIBILITY OF SUCH DAMAGE.

Skyworks products are not intended for use in medical, lifesaving or life-sustaining applications, or other equipment in which the failure of the Skyworks products could lead to personal injury, death, physical or environmental damage. Skyworks customers using or selling Skyworks products for use in such applications do so at their own risk and agree to fully indemnify Skyworks for any damages resulting from such improper use or sale.

Customers are responsible for their products and applications using Skyworks products, which may deviate from published specifications as a result of design defects, errors, or operation of products outside of published parameters or design specifications. Customers should include design and operating safeguards to minimize these and other risks. Skyworks assumes no liability for applications assistance, customer product design, or damage to any equipment resulting from the use of Skyworks products outside of stated published specifications or parameters.

Skyworks, the Skyworks symbol, and "Breakthrough Simplicity" are trademarks or registered trademarks of Skyworks Solutions, Inc., in the United States and other countries. Third-party brands and names are for identification purposes only, and are the property of their respective owners. Additional information, including relevant terms and conditions, posted at www.skyworksinc.com, are incorporated by reference.

X-ON Electronics

Largest Supplier of Electrical and Electronic Components

Click to view similar products for [RF Amplifier](#) category:

Click to view products by [Skyworks](#) manufacturer:

Other Similar products are found below :

[A82-1](#) [BGA622H6820XTSA1](#) [BGA 728L7 E6327](#) [BGB719N7ESDE6327XTMA1](#) [HMC397-SX](#) [HMC405](#) [HMC561-SX](#) [HMC8120-SX](#)
[HMC8121-SX](#) [HMC-ALH382-SX](#) [HMC-ALH476-SX](#) [SE2433T-R](#) [SMA3101-TL-E](#) [SMA39](#) [A66-1](#) [A66-3](#) [A67-1](#) [A81-2](#) [LX5535LQ](#)
[LX5540LL](#) [MAAM02350](#) [HMC3653LP3BETR](#) [HMC549MS8GETR](#) [HMC-ALH435-SX](#) [SMA101](#) [SMA32](#) [SMA411](#) [SMA531](#)
[SST12LP19E-QX6E](#) [WPM0510A](#) [HMC5929LS6TR](#) [HMC5879LS7TR](#) [HMC1087F10](#) [HMC1086](#) [HMC1016](#) [SMA1212](#) [MAX2689EWS+T](#)
[MAAMSS0041TR](#) [MAAM37000-A1G](#) [LTC6430AIUF-15#PBF](#) [SMA70-2](#) [SMA4011](#) [A231](#) [HMC-AUH232](#) [LX5511LQ](#) [LX5511LQ-TR](#)
[HMC7441-SX](#) [HMC-ALH310](#) [XD1001-BD-000V](#) [A4011](#)