

# UG475: Si823Hx Gate Driver Board

The Si823Hx Gate Driver Board (GDB) is ideal for driving power modules and discrete transistors. This two-channel isolated gate driver solution features a differential digital interface, optimized on-board isolated power supply, and user-configurable turn-on and turn-off gate resistors. Status indicator LEDs and test points make evaluation and prototyping easy.

## Ordering Information:

- [Si823H-AAWA-KIT - 1  \$\Omega\$  gate resistors](#)
- [Si823H-ABWA-KIT - 4  \$\Omega\$  gate resistors](#)

## Additional System Components:

The Si823Hx GDB is highly versatile but must be combined with other components to form a complete system. You can choose various vendors' elements to complete your evaluation or prototyping system and tailor it to your specific needs.

For example: Because the Si823Hx Gate Driver Board requires differential signal inputs, and most lab equipment only provides single-ended signals, it may prove helpful to use the Differential Transceiver Companion Tool, listed below, to provide that translation.

## Tested Components Include:

- [Half-Bridge Clamped Inductive Load \(CIL\) Test Fixture](#)
- [Wolfspeed WolfPACK™ Power Module](#)
- [Six-Pack Clamped Inductive Load \(CIL\) Test Fixture](#)
- [Differential Transceiver Companion Tool](#)

## TECHNICAL FEATURES

- Two input, high-side/low-side gate driver
- User programmable dead-time
- Overlap protection
- 4 A symmetric peak output current
- Available with 1  $\Omega$  or 4  $\Omega$  gate resistors
- Independent control of turn on/turn off timing through gate resistor selection
- Flexible isolated power supplies
- 5 kV<sub>RMS</sub> safety rated isolation
- 125 kV/ $\mu$ s common mode transient immunity (CMTI)
- DC bus voltage up to 800 V
- Reverse polarity protection for 12 V input supply
- Differential inputs for increased noise immunity
- Module temperature (NTC) output as frequency modulated digital signal
- Reference design available

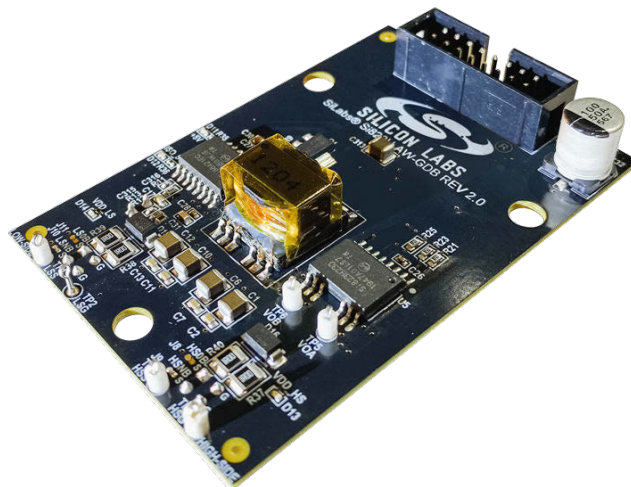

## 1. Electrical Specifications

Symbol	Parameter	Min	Nominal	Max	Unit
$V_{DC}$	Supply Voltage	10.2	12	13.2	V
$V_{IH}$	High Level Logic Input Voltage	2.0		5.5	
$V_{IL}$	Low Level Logic Input Voltage	0		0.8	
$f_S$	Maximum Switching Frequency (Module & MOSFET Dependent, see Power Estimate Section)		100		kHz
$T_{OP}$	Ambient Operating Temperature	-50		85	°C
$T_{STG}$	Storage Temperature	-50		125	

## 2. Pin Descriptions

**Table 2.1. Input Connectors**

Pin Number	Parameter	Description
1	VDC	Power supply input pin (+12 V Nominal Input)
2	Common	Common
3	HS-P <sup>1</sup>	Positive line of 5 V differential high-side PWM signal pair. Terminated Into 360 Ω.
4	HS-N <sup>1</sup>	Negative line of 5 V differential high-side PWM signal pair. Terminated into 360 Ω.
5	LS-P <sup>1</sup>	Positive line of 5 V differential low-side PWM signal pair. Terminated into 360 Ω.
6	LS-N <sup>1</sup>	Negative line of 5 V differential low-side PWM signal pair. Terminated into 360 Ω.
7	NC	Not Connected
8	NC	Not Connected
9	RTD-P <sup>1</sup>	Positive line of 5 V temperature dependent resistor output signal pair. Drive strength 20 mA. Temperature measurement is encoded via frequency.
10	RTD-N <sup>1</sup>	Negative line of 5 V temperature dependent resistor output signal pair. Drive strength 20mA. Temperature measurement is encoded via frequency.
11	NC	Not Connected
12	Common	Common
13	PWM EN	Pull down or leave floating to disable PWM input logic. Pull up to enable. Gate driver output will be held low through turn-off gate resistor if power supplies are enabled.
14	Common	Common
15	NC	Not Connected
16	Common	Common
<p><b>Note:</b></p> <p>1. Inputs 3 – 6, 9, and 10 are differential pairs.</p>		

### 3. Signal Descriptions

- **PWM Signals:** High-side and low-side PWM are RS-422 compatible differential inputs. The termination impedance of the differential receiver is 360  $\Omega$ . Overlap protection is provided to prevent both the high-side and low-side gates from turning on simultaneously. The overlap protection should not be used as a dead time generator. Programmable dead time is provided by resistor selection. See section XXX.
- **RTD (NTC):** RTD output is a differential signal that returns the resistance of the temperature sensor (NTC) integrated into some modules. The signal is a frequency modulated signal that encodes the resistance of the temperature sensor. The approximate temperature of the module can be determined from this resistance. See the section [Temperature Feedback](#) for further details.
- **PWM EN:** This is a single-ended input that enables the PWM inputs for both channels. When this signal is pulled down, or left floating, the isolated drivers for both channels are disabled and the gates will both be pulled low through  $R_{G-OFF}$ . All protection circuitry and power supplies will continue to operate including the RTD output.
- **Over-Voltage and Reverse Polarity Protection:** Power input on pin 1 of the gate driver board input connector features a power management circuit to protect the gate driver from damage by connecting a power source that exceeds the voltage rating of the gate driver. There is a diode and MOSFET in-line with the power input to protect against connecting a power source with positive and negative polarity reversed.

#### 4. Truth Table

PWM-HS	PWM-LS	PWM EN	UVLO	HS Gate	LS Gate
H	L	H	No	H	L
L	H	H	No	L	H
L	L	H	No	L	L
H	H	X	No	L	L
X	X	L or Z	No	L	L
X	X	X	Yes	L	L

**H = High | L = Low | X = Irrelevant | Z = High Impedance**

## 5. Gate Driver Interface

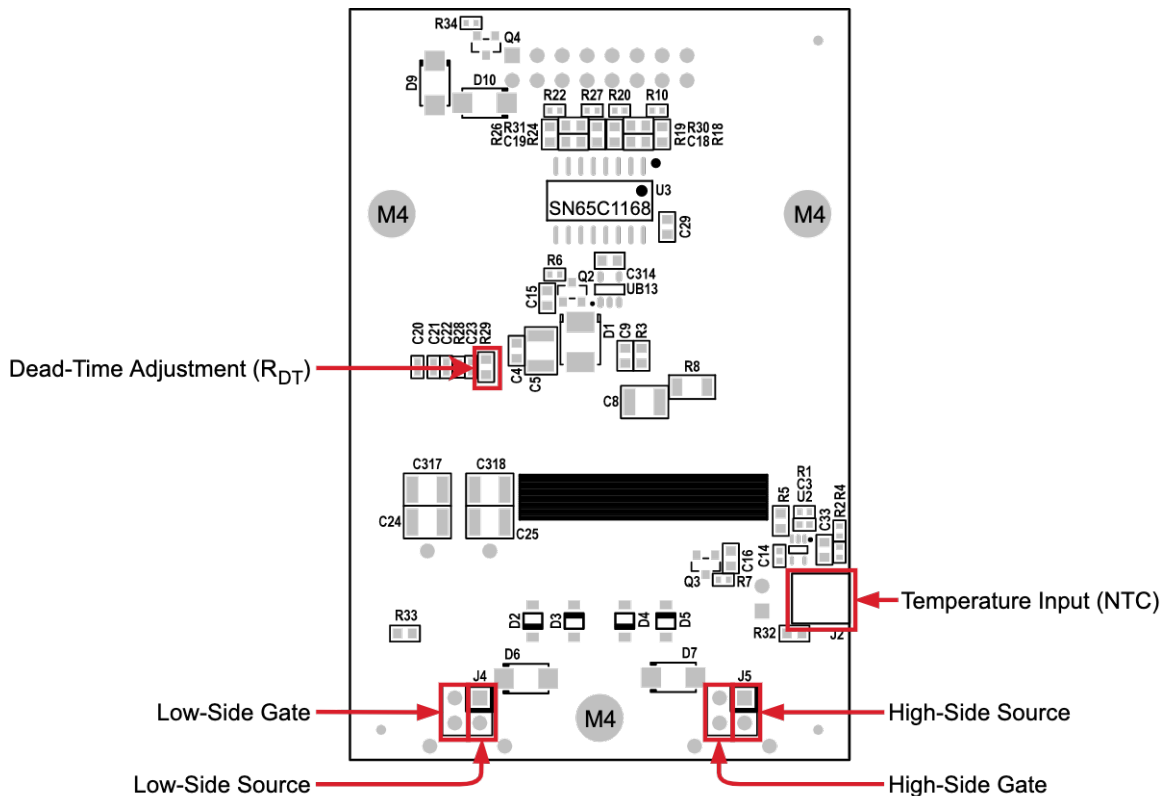
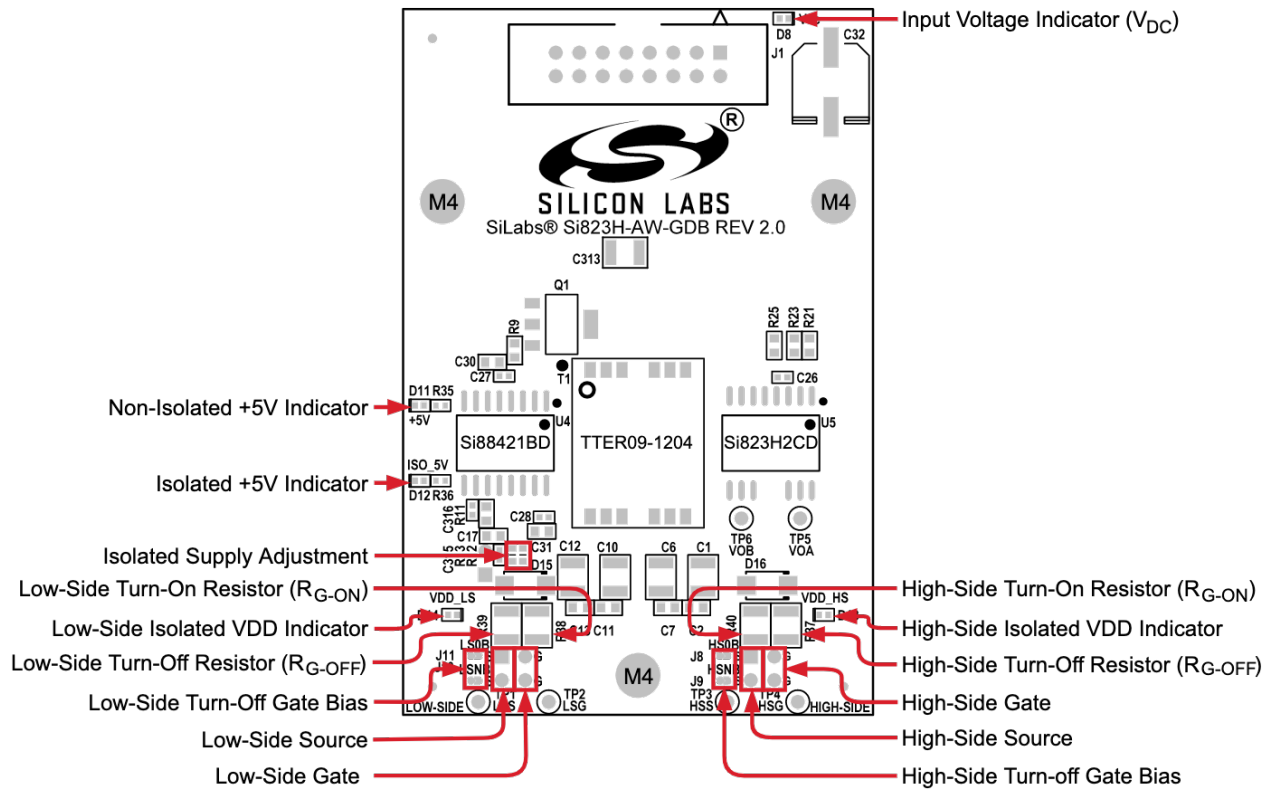

## 6. Function Block Diagram

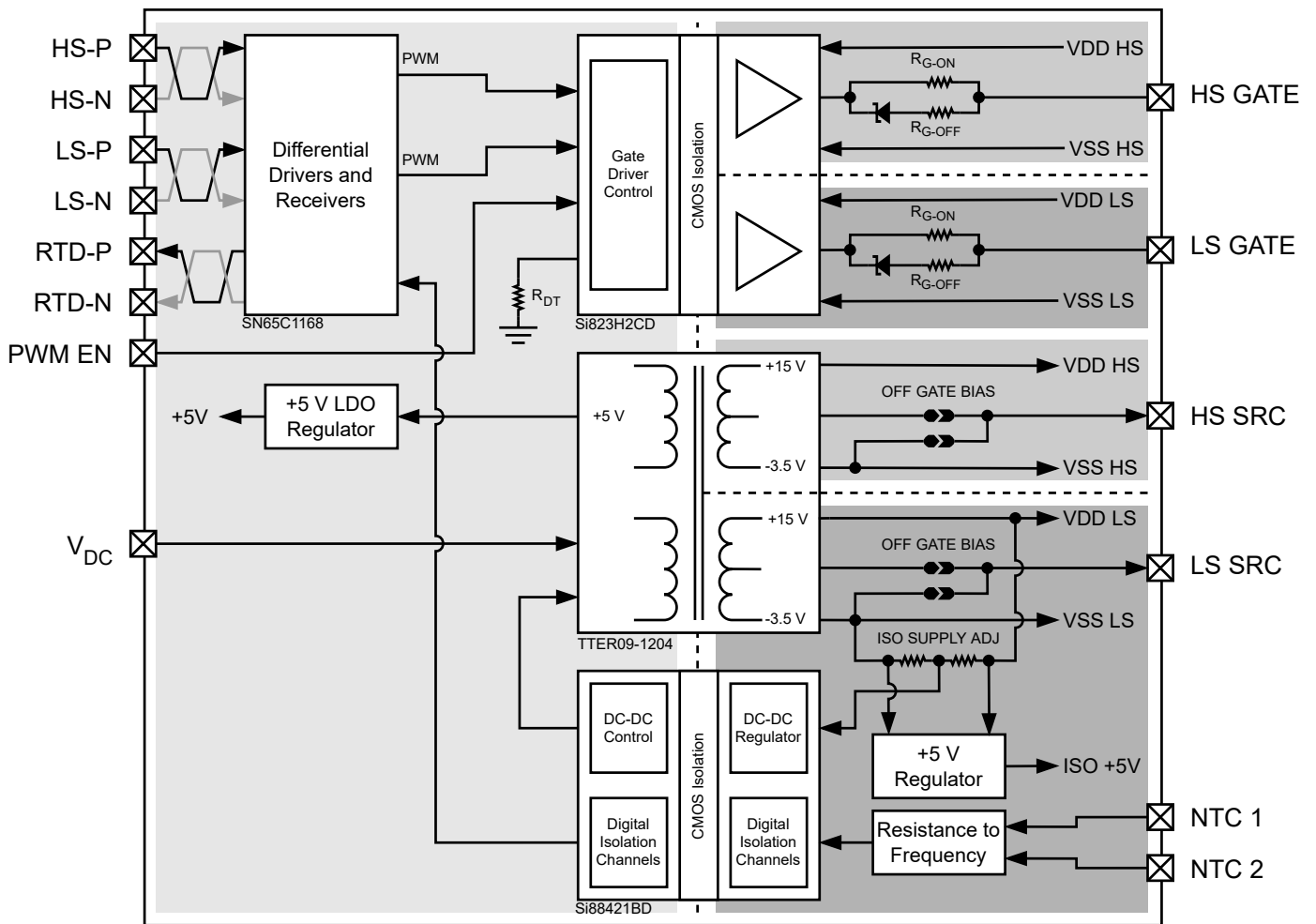

## 7. Temperature Feedback

Many power modules use a thermistor to provide temperature feedback of the power switching devices. If a thermistor is provided on the module, it can be connected to the driver board. The resistance of that sensor is converted to a 50% duty cycle square wave with a frequency that varies inversely with the resistance. The resistance to frequency relationship is displayed in the table below. The resistance measurement circuit is located on the low-side gate drive channel, and a digital isolator is used to transmit the frequency-encoded signal back to the primary side of the driver. For this reason, the temperature signal does not need any additional isolation, and can be included in the same cable as the rest of the gate driver's signals. The temperature reported by the sensor may differ from the junction temperature of the transistors used in the module.

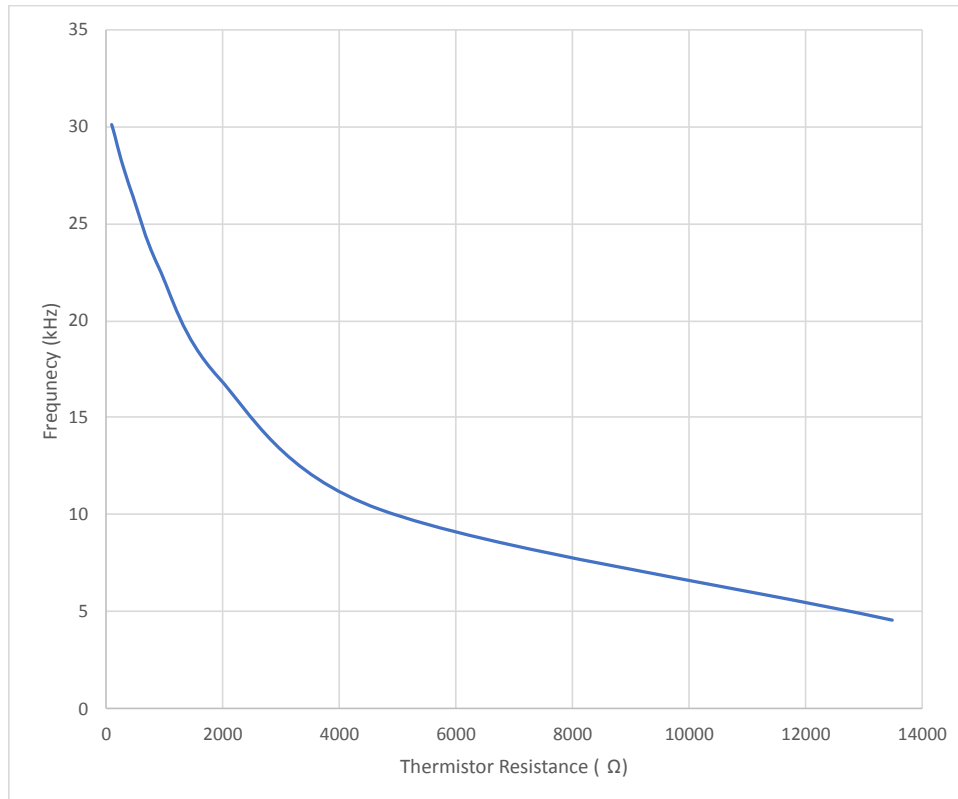

**Figure 7.1. Thermistor Resistance vs. Output Frequency**

Thermistor Resistance (Ω)	Frequency Output (kHz)
13,491	4.6
4,700	10.3
1,928	17.1
898	22.8
464	26.4
260	28.3
156	29.5
99	30.1



## 8. Connector Information

### 8.1 Input Connector Information

- 16 Positions Header, 0.100" (2.54 mm) Pitch, Through Hole, Gold (SBH11-PBPC-D08-ST-BK)

### 8.2 Suggested Mating Parts

- 16 Position Rectangular Header, IDC, Gold, 28 AWG (SFH210-PPPC-D08-ID-BK)
- 16 Position Header, 0.100" (2.54 mm) Pitch, Through Hole, Gold (SFH11-PBPC-D08-RA-BK)
- 16 Position Header, 0.100" (2.54 mm) Pitch, Through Hole, Right Angle, Gold (SFH11-PBPC-D08-RA-BK)

### 8.3 Output Connector Information

- 4 Positions Header, 0.100" (2.54 mm) Pitch, Through Hole, Gold (Samtec® ESQ-102-33-L-D)

## 9. User Configurable Options

### 9.1 Dead Time

Dead Time is a user selectable delay between the falling edge of the gate drive signal on one channel and the rising edge of the gate drive signal on the other channel. The value of this delay is programmable through the selection of a dead time resistor ( $R_{DT}$ ) on the Si823H2 driver. In this application, resistor R29 is that dead time resistor. The allowed range of the value of the dead time resistor is 6 k $\Omega$  to 100 k $\Omega$ . This provides a range of dead time between 20 nsec and 200 nsec. The relationship between dead time and the value of the dead time resistor is described by the equation:

$$Dead\ Time \approx 1.8 \times (R_{DT}) + 12$$

Where Dead Time is in nsec and  $R_{DT}$  is in k $\Omega$ .

To change the dead time value, the user would remove R29 and replace it with the calculated value based on the desired dead time. For additional information about dead time, refer to the [Si823Hx data sheet](#).

### 9.2 Series Gate Resistors

The Si823Hx GDB is available in two orderable configurations: one with 1  $\Omega$  series gate resistors (Si823H-AAWA-KIT) and another with 4  $\Omega$  gate resistors (Si823H-ABWA-KIT). These configurations have the same value of resistor in-series with the gate drive signal for both the high side and the low side channels. In addition, these resistor values are the same for both turn on ( $R_{G-ON}$ ) and turn off ( $R_{G-OFF}$ ).

However, the user can select any value for turn on and turn off timing control independently. Resistors R37 and R38 control the turn on timing for the high side and low side channels respectively. Resistors R40 and R39 affect the turn off time for the high side and low side respectively. Resistors R40 and R39 are connected in the gate drive path through diodes D15 and D16 such that they will effectively be in parallel with the turn on time resistors (see the schematic for reference). This configuration provides the user with complete flexibility in tuning the turn on and turn off times for each channel.

### 9.3 Negative Gate Bias

The default configuration of this driver board provides a gate drive signal that swings from +15 V to -3.5 V with respect to the source pin connection. The user can change this configuration using the solder bump jumpers J8 and J9 for the high side and J10 and J11 for the low side (OFF GATE BIAS). By removing the solder on J9 for the high side, or J10 for the low side, and adding solder to short the pads on J8 for the high side, or J11 for the low side, the output of the driver board will swing from +18.5 V to 0 V with respect to the source pin. To reduce the "on" state voltage in this configuration, the user will need to adjust the output of the isolated power supply converter as described in the next section.

### 9.4 Isolated Driver Power Supply Voltage

The Si823Hx GDB uses a dc-dc converter integrated into the Si88421 digital isolator. This converter regulates the output of one secondary of the transformer used in the application. The design of the transformer provides regulation of the other secondary winding to provide separate, isolated power supplies for both the high side and low side driver. The default configuration provides a driver power supply that is regulated to roughly 19 V. Since the source pin of each channel is biased about 3.5 V above the converter's reference, the gate will see a voltage swing from +15 V to -3.5 V when measured with respect to the source pin. As mentioned in the previous section, the board can be configured to eliminate the negative bias for the gate voltage by connecting the source pins directly to the converter's reference. However, this will cause the gate voltage to swing to +18.5 V with respect to the source pin. To adjust this, the user can modify the voltage feedback resistor network (ISO SUPPLY ADJ). Resistors R12 and R13 provide a feedback path for the integrated dc-dc converter controller. By adjusting the ratio of these resistors, the output voltage of the converter can be adjusted.

The converter expects the feedback divider to provide a sense voltage of 1.05 V on pin 13 of the Si88421 (VSNS). The output voltage can thus be described by the following equation:

$$V_{OUT} = \frac{(R12 + R13)}{R13} V_{SNS}$$

This equation demonstrates that replacing R13 with a 10.9 k $\Omega$  resistor will provide a  $V_{out}$  of close to 15 V.

## 10. Supporting Links & Tools

- [Silicon Labs Si823Hx data sheet](#)
- [Silicon Labs Si88x2x data sheet](#)
- Si823Hx Gate Driver Board Reference Designs:
  - [Si823Hx-AAWA-KIT](#)
  - [Si823Hx-ABWA-KIT](#)
- [AN892: Design Guide for Isolated DC-DC Using the Si882xx/883xx](#)
- [AN901: Design Guide for Isolated DC-DC Using the Si884xx/886xx](#)
- [AN1131: Design Guide for Reducing Radiated and Conducted Emissions in Isolated Systems Using Silicon Labs' Isolators](#)
- [AN1167: Safety Considerations for Silicon Labs Series Capacitor Isolators](#)

### 11. Dimensions

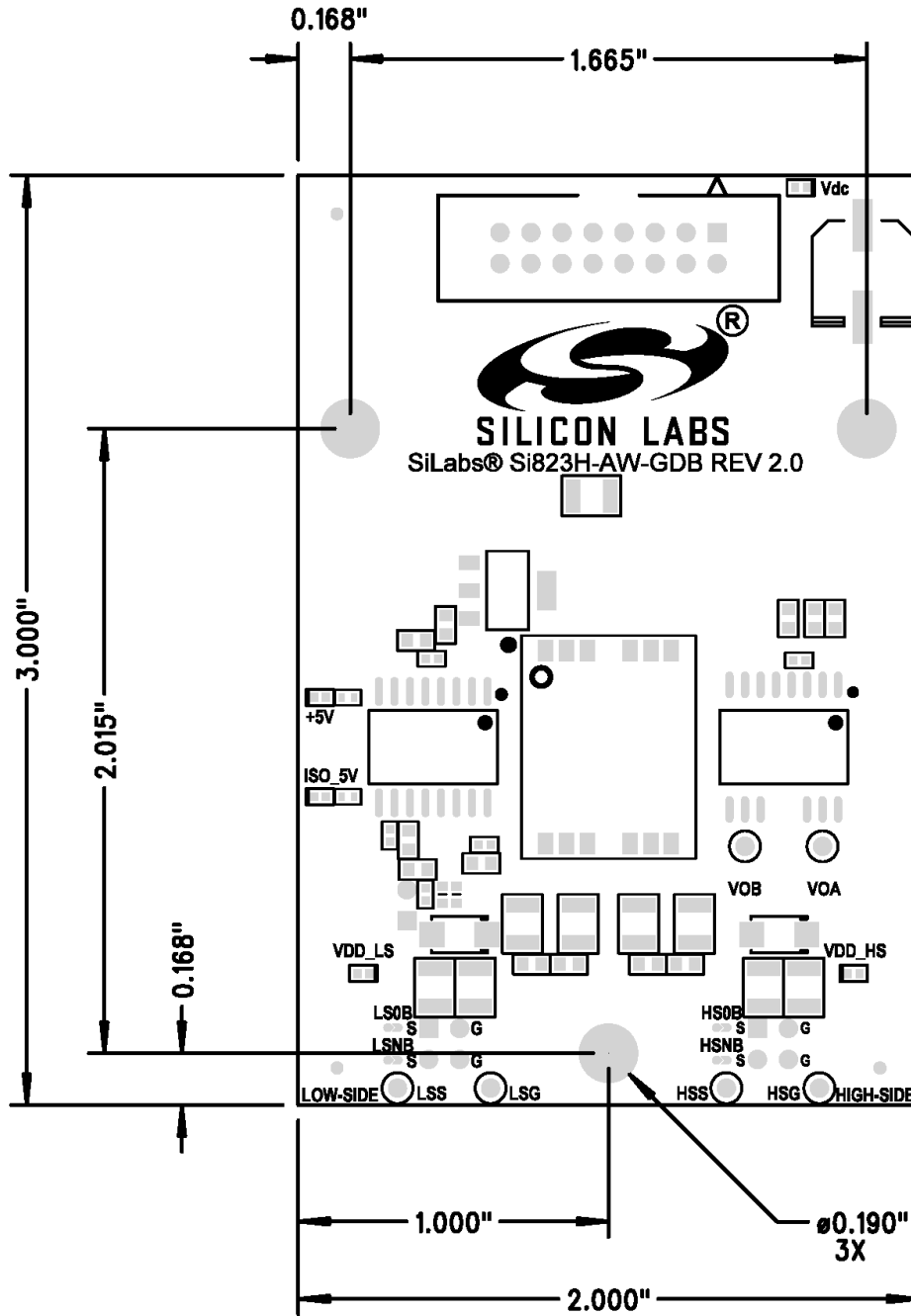

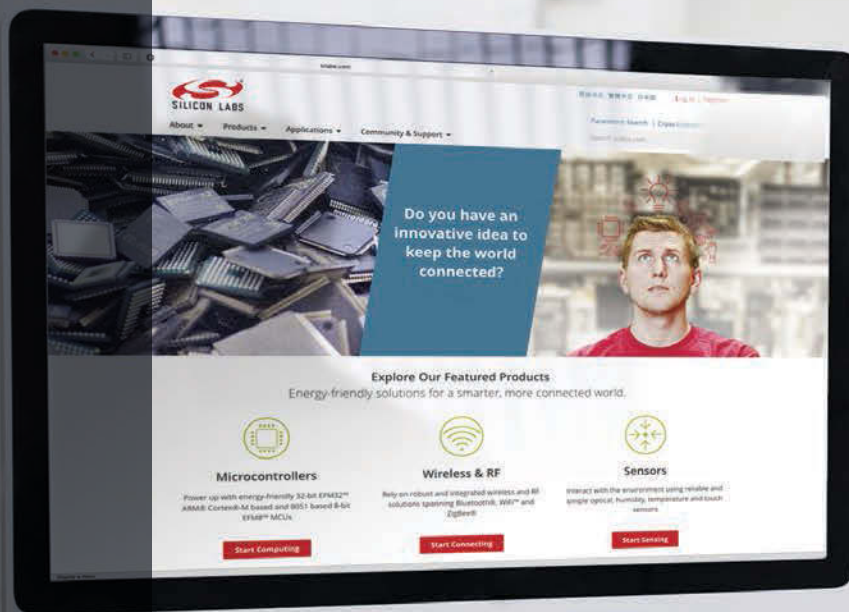

Smart.  
Connected.  
Energy-Friendly.



**Products**  
[www.silabs.com/products](http://www.silabs.com/products)

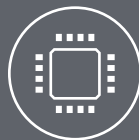

**Quality**  
[www.silabs.com/quality](http://www.silabs.com/quality)



**Support and Community**  
[community.silabs.com](http://community.silabs.com)

**Disclaimer**

Silicon Labs intends to provide customers with the latest, accurate, and in-depth documentation of all peripherals and modules available for system and software implementers using or intending to use the Silicon Labs products. Characterization data, available modules and peripherals, memory sizes and memory addresses refer to each specific device, and "Typical" parameters provided can and do vary in different applications. Application examples described herein are for illustrative purposes only. Silicon Labs reserves the right to make changes without further notice to the product information, specifications, and descriptions herein, and does not give warranties as to the accuracy or completeness of the included information. Without prior notification, Silicon Labs may update product firmware during the manufacturing process for security or reliability reasons. Such changes will not alter the specifications or the performance of the product. Silicon Labs shall have no liability for the consequences of use of the information supplied in this document. This document does not imply or expressly grant any license to design or fabricate any integrated circuits. The products are not designed or authorized to be used within any FDA Class III devices, applications for which FDA premarket approval is required, or Life Support Systems without the specific written consent of Silicon Labs. A "Life Support System" is any product or system intended to support or sustain life and/or health, which, if it fails, can be reasonably expected to result in significant personal injury or death. Silicon Labs products are not designed or authorized for military applications. Silicon Labs products shall under no circumstances be used in weapons of mass destruction including (but not limited to) nuclear, biological or chemical weapons, or missiles capable of delivering such weapons. Silicon Labs disclaims all express and implied warranties and shall not be responsible or liable for any injuries or damages related to use of a Silicon Labs product in such unauthorized applications.

**Trademark Information**

Silicon Laboratories Inc.®, Silicon Laboratories®, Silicon Labs®, SiLabs® and the Silicon Labs logo®, Bluegiga®, Bluegiga Logo®, ClockBuilder®, CMEMS®, DSPLL®, EFM®, EFM32®, EFR®, Ember®, Energy Micro, Energy Micro logo and combinations thereof, "the world's most energy friendly microcontrollers", Ember®, EZLink®, EZRadio®, EZRadioPRO®, Gecko®, Gecko OS, Gecko OS Studio, ISOModem®, Precision32®, ProSLIC®, Simplicity Studio®, SiPHY®, Telegesis, the Telegesis Logo®, USBXpress®, Zentri, the Zentri logo and Zentri DMS, Z-Wave®, and others are trademarks or registered trademarks of Silicon Labs. ARM, CORTEX, Cortex-M3 and THUMB are trademarks or registered trademarks of ARM Holdings. Keil is a registered trademark of ARM Limited. Wi-Fi is a registered trademark of the Wi-Fi Alliance. All other products or brand names mentioned herein are trademarks of their respective holders.



Silicon Laboratories Inc.  
400 West Cesar Chavez  
Austin, TX 78701  
USA

<http://www.silabs.com>

## X-ON Electronics

Largest Supplier of Electrical and Electronic Components

*Click to view similar products for [Power Management IC Development Tools](#) category:*

*Click to view products by [Skyworks](#) manufacturer:*

Other Similar products are found below :

[EVB-EP5348UI](#) [BQ25010EVM](#) [ISLUSBI2CKIT1Z](#) [ISL8002AEVAL1Z](#) [ISL91108IIA-EVZ](#) [ISL28022EVKIT1Z](#) [STEVAL-ISA008V1](#)  
[DRI0043](#) [NCP10671B05GEVB](#) [EVB-EN6337QA](#) [SAMPLEBOXILD8150TOBO1](#) [AP63300WU-EVM](#) [AP61100Z6-EVM](#)  
[KITA2GTC387MOTORCTRTOBO1](#) [AEK-MOT-TK200G1](#) [EVLONE65W](#) [STEVAL-ILH006V1](#) [STEVAL-IPE008V2](#) [STEVAL-IPP001V2](#)  
[STEVAL-ISA013V1](#) [STEVAL-ISA067V1](#) [STEVAL-ISQ002V1](#) [TPS2306EVM-001](#) [TPS2330EVM-185](#) [TPS40001EVM-001](#) [SECO-](#)  
[HVDCDC1362-15W-GEVB](#) [BTS7030-2EPA](#) [LTC3308AIV#WTRPBF](#) [TLT807B0EPV](#) [BTS71033-6ESA](#) [EV13N91A](#) [EV55W64A](#)  
[Si8285\\_86v2-KIT](#) [NCP-NCV51752D2PAK3LGEVB](#) [ISL81807EVAL1Z](#) [EVALM7HVIGBTPFCINV4TOBO1](#) [903-0300-000](#) [902-0173-000](#)  
[903-0301-000](#) [ROA1286023/1](#) [REFSHA35IMD111TSYSTOBO1](#) [150037482](#) [TDINV3000W50B-KIT](#) [NCP1681CCM1KWGEVB](#) [I7C08A-](#)  
[CC3-EVK-P2](#) [I7C12A-CC3-EVK-P2](#) [i7C20A-CC3-EVK-P2](#) [APEK89303KET-01-T](#) [NCP1681MM500WGEVB](#) [SI83401BAA-KIT](#)