

Si8931/32 Data Sheet

Isolated Amplifier for Voltage Measurement

The Si8931/32 is a galvanically isolated analog amplifier optimized for voltage sensing. Its 2.5 V input range is ideal for isolated voltage sensing applications. The output is a differential analog signal (Si8931) or single-ended signal (Si8932) that is proportional to the input voltage.

The Si8931/32 provides excellent linearity with low offset and gain drift to ensure that accuracy is maintained over the entire operating temperature range. Exceptionally high common-mode transient immunity means that the Si8931/32 delivers accurate measurements even in the presence of high-power switching as is found in motor drive systems and inverters.

The Si8931/32 isolated voltage sensing amplifier utilizes Skyworks' proprietary isolation technology. It supports up to 5.0 kVrms withstand voltage per UL1577. This technology enables higher performance, reduced variation with temperature and age, tighter part-to-part matching, and longer lifetimes compared to other isolation technologies.

Applications:

- Industrial, HEV and renewable energy inverters
- AC, Brushless, and DC motor controls and drives
- Variable speed motor control in consumer white goods
- Isolated switch mode and UPS power supplies
- General industrial data acquisition and sensor interface
- Automotive onboard chargers, battery management systems, and charging stations

Safety Approvals (pending):

- UL 1577 recognized
 - Up to 5000 Vrms for 1 minute
- CSA approval
 - IEC 60950-1, 62368-1 (reinforced insulation)
- VDE certification conformity
 - VDE0884 Part 11 (basic/reinforced insulation)
- CQC certification approval
 - GB4943.1-2011

KEY FEATURES

- 0 to 2.5 V nominal input voltage
- Low signal delay: 1 μ s
- Typical input offset: 0.16 mV
- Typical gain error: \pm 0.06%
- Excellent drift specifications
 - 0.75 μ V/ $^{\circ}$ C offset drift
 - 6 ppm/ $^{\circ}$ C typical gain drift
- Typical nonlinearity: 0.01%
- Typical SNR: 76 dB
- High common-mode transient immunity: 75 kV/ μ s
- Automotive-grade OPNs
 - AIAG-compliant PPAP documentation support
 - IMDS and CAMDS listing support
- Compact packages
 - 8-pin wide body stretched SOIC
 - 8-pin narrow body SOIC
- -40 to 125 $^{\circ}$ C

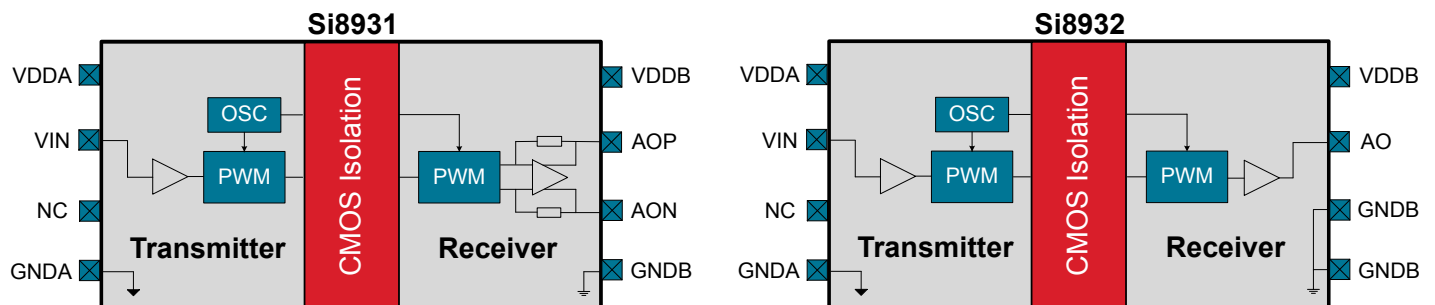

1. Ordering Guide

Ordering Part Number ^{1, 2, 3}	Automotive Ordering Part Number ^{1, 2, 3, 4}	Ordering Options			
		Input Range	Isolation Rating	Output	Package Type
Si8931D-IS4	Si8931D-AS4	0 to 2.5 V nominal	5.0 kVrms	Differential	WB Stretched SOIC-8
Si8931B-IS	Si8931B-AS	0 to 2.5 V nominal	2.5 kVrms	Differential	NB SOIC-8
Si8932D-IS4	Si8932D-AS4	0 to 2.5 V nominal	5.0 kVrms	Single-ended	WB Stretched SOIC-8
Si8932B-IS	Si8932B-AS	0 to 2.5 V nominal	2.5 kVrms	Single-ended	NB SOIC-8

Note:

1. All packages are RoHS-compliant.
2. "Si" and "SI" are used interchangeably.
3. AEC-Q100 pending qualification.
4. Automotive-Grade devices ("-A" suffix) are identical in construction materials, topside marking, and electrical parameters to their Industrial Grade ("-I suffix") version counterparts. Automotive-Grade products are produced utilizing full automotive process flows and additional statistical process controls throughout the manufacturing flow. The Automotive-Grade part number is included on shipping labels.

Table of Contents

1. Ordering Guide	2
2. System Overview	4
2.1 Fail-Safe and Low-Power Modes	5
3. Voltage Sense Application	6
4. Electrical Specifications	7
4.1 Regulatory Information	.12
4.2 Typical Operating Characteristics	.14
5. Pin Descriptions	19
5.1 Si8931 Pin Descriptions	.19
5.2 Si8932 Pin Descriptions	.20
6. Packaging	21
6.1 Package Outline: 8-Pin Wide Body Stretched SOIC	.21
6.2 Package Outline: 8-Pin Narrow Body SOIC	.23
6.3 Land Pattern: 8-Pin Wide Body Stretched SOIC	.25
6.4 Land Pattern: 8-Pin Narrow Body SOIC	.26
6.5 Top Marking: 8-Pin Wide Body Stretched SOIC	.27
6.6 Top Marking: 8-Pin Narrow Body SOIC	.28
7. Revision History	29

2. System Overview

The input to the Si8931/32 is designed for 0 to 2.5 V nominal input.

The Si8931/32 modulates the analog signal in a unique way for transmission across the semiconductor based isolation barrier. The input signal is first converted to a pulse-width modulated digital signal. On the other side of the isolation barrier, the signal is demodulated to faithfully reproduce the analog signal. This solution provides exceptional signal bandwidth and accuracy. The Si8931 provides a differential voltage output while the Si8932 provides a single-ended voltage output.

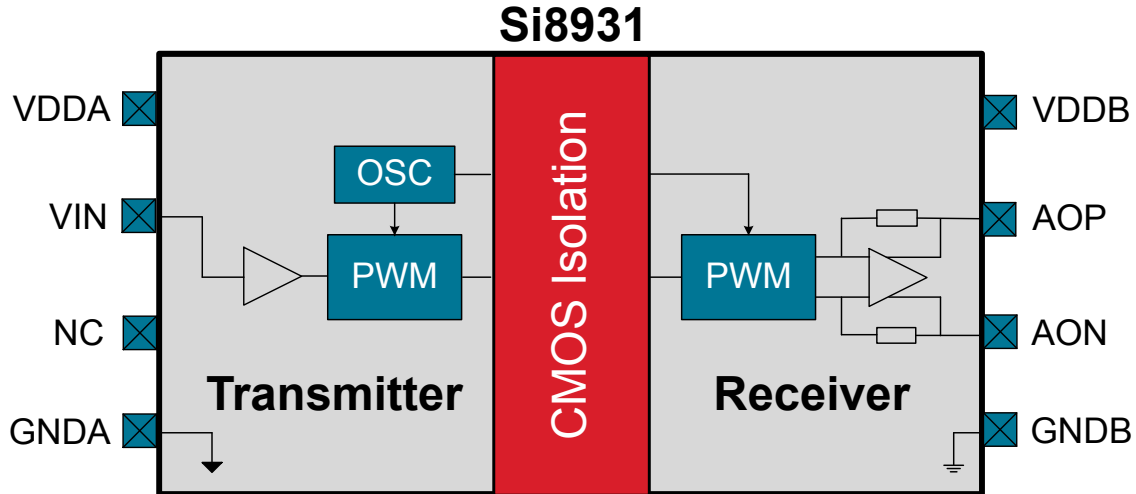

Figure 2.1. Si8931 Functional Block Diagram

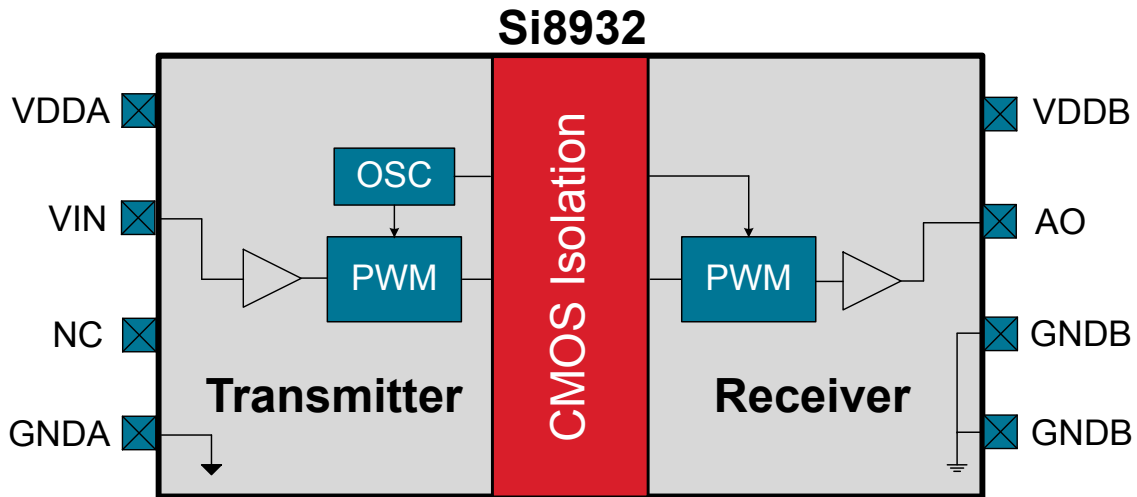

Figure 2.2. Si8932 Functional Block Diagram

2.1 Fail-Safe and Low-Power Modes

The Si8931/32 implements a fail-safe output when the high-side supply voltage VDDA goes away. This is important for safe operation in systems with high safety requirements. The fail-safe output is nominally 2.8 V (Si8932) or -2.8 V (Si8931) which can be differentiated from the maximum clipping output voltage of 2.6 V to simplify diagnostics on the system level.

Device	Output Voltage (VDDA Normal)	Output Voltage (VDDA Removed)
Si8931	~ ±2.6 V	~ -2.8 V
Si8932	0 to ~2.6 V	~ +2.8 V

In addition to the fail-safe output, when a loss of VDDA supply occurs, the part will automatically move into a lower power mode that reduces IDDB current to approximately 1 mA. The controller side continues to monitor high-side communications to determine when VDDA supply returns. When the supply voltage is returned, normal operation begins in approximately 250 μ s. Similarly, a loss of VDDB supply will reduce IDDA current to approximately 1 mA.

3. Voltage Sense Application

A typical isolated voltage sensing application circuit is shown below. In this example, a high voltage is divided down to produce a voltage (V_{IN}) within the optimum input signal range of the Si8931/32. Numerous alternative inputs configurations are possible with the flexibility of a high impedance input isolator. The Si8931 senses the single-ended input voltage and reproduces it as a differential (or single-ended with the Si8932) output voltage across the galvanic isolation barrier. The Si8931 differential outputs (AOP, AON) can be routed directly to a differential ADC as shown below. The Si8932 senses the single-ended input voltage and reproduces it as a single-ended output voltage across the galvanic isolation barrier. The single-ended output can be routed directly to a standard ADC (not shown). If the voltage sensed is > 2.5 V, a simple voltage divider consisting of R_1 and R_2 can be used to scale down any voltage to fit the input range of the Si8931/32. $R_2 < 10$ k Ω is recommended for best performance.

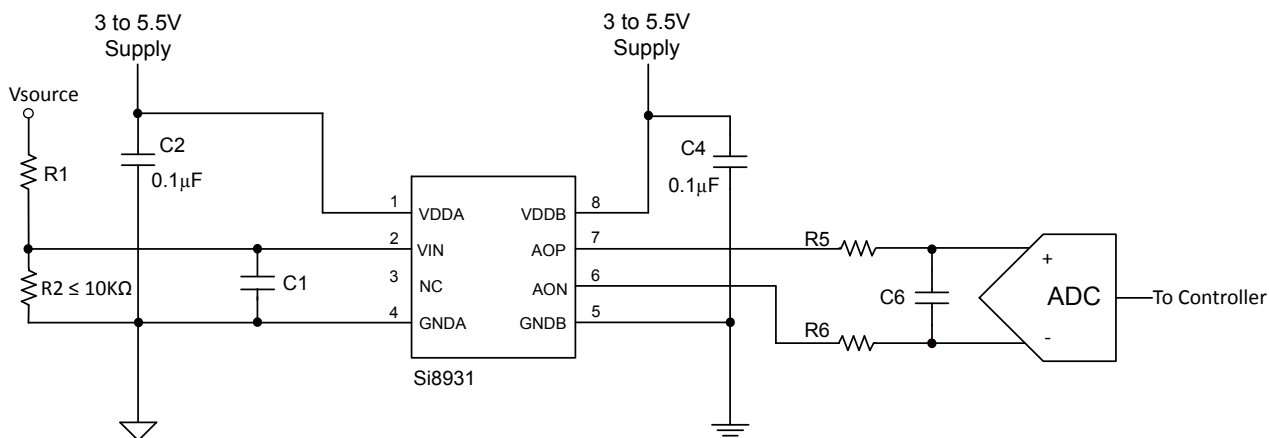

Figure 3.1. Voltage Sense Application

The amplifier bandwidth of the Si8931/32 is approximately 600 kHz. For applications where input filtering is required, a passive, differential RC low-pass filter can be placed at the input pin. Consider the source resistance of the signal measured (or the parallel combination of R_1 and R_2 if using a voltage divider) as it should be included in the filter calculation. Capacitor C_1 should be sized to make a band limiting filter at the desired frequency.

C_4 , the local bypass capacitor for the B-side of Si8931/32, should be placed close to V_{DDB} supply pin with its return close to $GNDB$. The output signal at AOP and AON is differential with unity gain and common mode of 1.4 V. The outputs are sampled by a differential input ADC. Depending on the sample rate of the ADC, an anti-aliasing filter may be required. A simple anti-aliasing filter can be made from the passive components, R_5 , C_6 , and R_6 . The characteristics of this filter are dictated by the input topology and sampling frequency of the ADC. However, to ensure the Si8931/32 outputs are not overloaded, $R_5 = R_6 > 5$ k Ω and C_6 can be calculated by the following equation:

$$C_6 = \frac{1}{2 \times \pi \times (R_5 + R_6) \times f_{3dB}}$$

4. Electrical Specifications

Table 4.1. Electrical Specifications
 $T_A = -40$ to $+125$ °C; typical specs at 25 °C with $V_{DDA} = V_{DDB} = 5$ V unless specified differently under Test Condition

Parameter		Symbol	Test Condition	Min	Typ	Max	Units
Input Side Supply Voltage		VDDA		3.0		5.5	V
Input Supply Current	Si8931/32	IDDA	VDDA = 3.3 V	3.8	4.7	5.7	mA
Output Side Supply Voltage		VDDB		3.0		5.5	V
Output Supply Current	Si8931	IDDB	VDDB = 3.3 V	2.8	3.5	4.5	mA
	Si8932	IDDB	VDDB = 3.3 V	3	4.3	5	mA
Amplifier Bandwidth					600		kHz
Amplifier Input							
Specified Linear Input Range		VIN		0.25		2.25	V
Maximum Input Voltage before Clipping		VIN			2.5		V
Input Referred Offset		VOS	$T_A = 25$ °C, $V_{IN} = 0.25$ V	-1	±0.16	1	mV
Input Offset Drift		VOS _T		-25	±0.75	25	µV/°C
Input Impedance		RIN			500		MΩ
Amplifier Output							
Full-scale Output					2.5		V _{pk}
Gain					1		
Gain Error			$T_A = 25$ °C	-0.25	±0.06	0.25	%
Gain Error Drift	Si8931			-40	6	20	ppm/°C
	Si8932			-30	-5	30	ppm/°C
Output Common Mode Voltage		Si8931	(VAOP + VAON)/2	1.34	1.39	1.44	V
Nonlinearity	Si8931		$T_A = 25$ °C	-0.04	0.01	0.04	%
	Si8932		$T_A = 25$ °C	-0.05	0.01	0.05	%
Nonlinearity Drift			$T_A = 25$ °C	-5		5	ppm/°C
Signal-to-Noise Ratio	Si8931	SNR	100 kHz bandwidth	73	77		dB
	Si8932	SNR	100 kHz bandwidth	72	76		dB
Total Harmonic Distortion	Si8931	THD	$F_{IN} = 1$ kHz		-80	-70	dB
	Si8932	THD	$F_{IN} = 1$ kHz		-80	-66	dB

Parameter		Symbol	Test Condition	Min	Typ	Max	Units
Power Supply Rejection Ratio		PSRR	VDDA at DC		-100		dB
			VDDA at 100 mV and 10 kHz ripple		-100		dB
			VDDB at DC		-100		dB
			VDDB at 100 mV and 10 kHz ripple		-100		dB
Output Resistive Load	Si8931	RLOAD	Between AON and AOP	5			k Ω
	Si8932		Between AO and GND	5			k Ω
Output Capacitive Load		CLOAD	Each pin to ground			100	pF
Timing							
Signal Delay		t_{PD}	50% to 50%		1		μ s
Rise Time		t_R	10% to 90%		1.6		μ s
Common-Mode Transient Immunity ¹		CMTI	VIN = GNDA, VCM = 1500 V	50	75		kV/ μ s
Note:							
1. An analog CMTI failure is defined as an output error of more than 100 mV persisting for at least 1 μ s.							

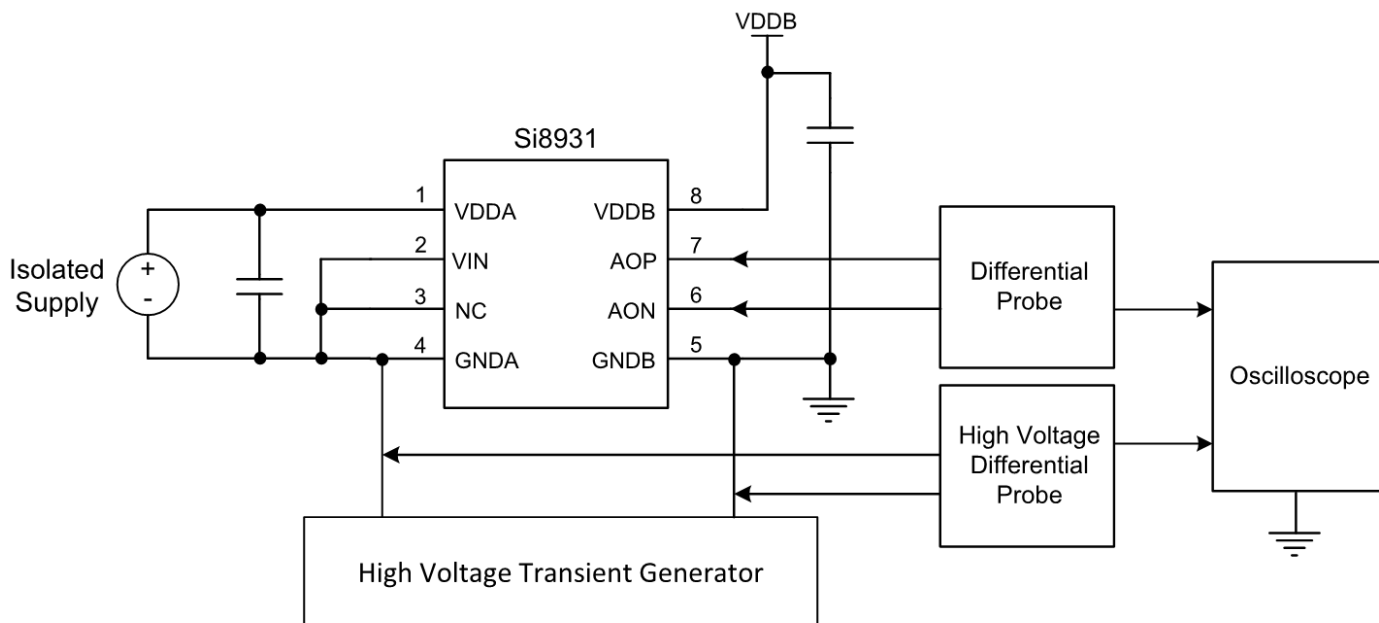

Figure 4.1. Common-Mode Transient Immunity Characterization Circuit

Table 4.2. IEC Safety Limiting Values¹

Parameter	Symbol	Test Condition	Characteristic	Unit
Safety Temperature	T_S		150	°C
Safety Input Current (WB Stretched SOIC-8)	I_S	$\theta_{JA} = 90 \text{ }^\circ\text{C/W}$ $V_{DD} = 5.5 \text{ V}$ $T_J = 150 \text{ }^\circ\text{C}$ $T_A = 25 \text{ }^\circ\text{C}$	253	mA
		$\theta_{JA} = 90 \text{ }^\circ\text{C/W}$ $V_{DD} = 3.6 \text{ V}$ $T_J = 150 \text{ }^\circ\text{C}$ $T_A = 25 \text{ }^\circ\text{C}$	386	mA
Safety Input Current (NB SOIC-8)	I_S	$\theta_{JA} = 112 \text{ }^\circ\text{C/W}$ $V_{DD} = 5.5 \text{ V}$ $T_J = 150 \text{ }^\circ\text{C}$ $T_A = 25 \text{ }^\circ\text{C}$	203	mA
		$\theta_{JA} = 112 \text{ }^\circ\text{C/W}$ $V_{DD} = 3.6 \text{ V}$ $T_J = 150 \text{ }^\circ\text{C}$ $T_A = 25 \text{ }^\circ\text{C}$	310	mA
Safety Input Power (WB Stretched SOIC-8)	P_S	$\theta_{JA} = 90 \text{ }^\circ\text{C/W}$ $T_J = 150 \text{ }^\circ\text{C}$ $T_A = 25 \text{ }^\circ\text{C}$	1389	mW
Safety Input Power (NB SOIC-8)	P_S	$\theta_{JA} = 112 \text{ }^\circ\text{C/W}$ $T_J = 150 \text{ }^\circ\text{C}$ $T_A = 25 \text{ }^\circ\text{C}$	1116	mW
Device Power Dissipation (WB Stretched SOIC-8)	P_D		1.39	W
Device Power Dissipation (NB SOIC-8)			1.12	W
Note:				
1. Maximum value allowed in the event of a failure. Refer to the thermal derating curves below.				

Table 4.3. Thermal Characteristics

Parameter	Symbol	WB Stretched SOIC-8	NB SOIC-8	Unit
IC Junction-to-Air Thermal Resistance	θ_{JA}	90	112	°C/W

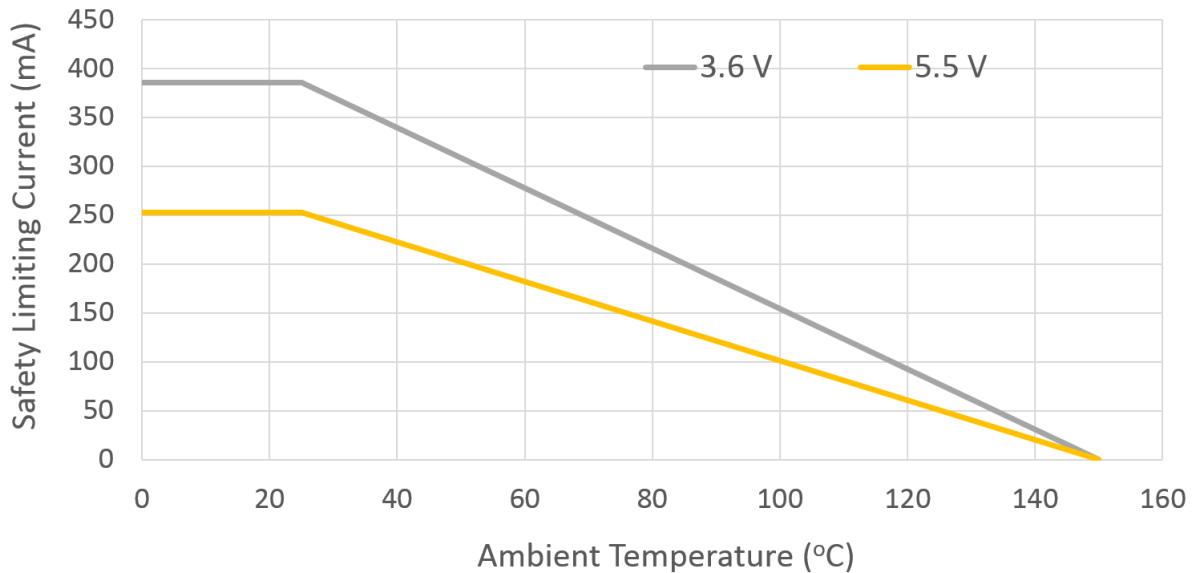

Figure 4.2. WB Stretched SOIC-8 Thermal Derating Curve for Safety Limiting Current

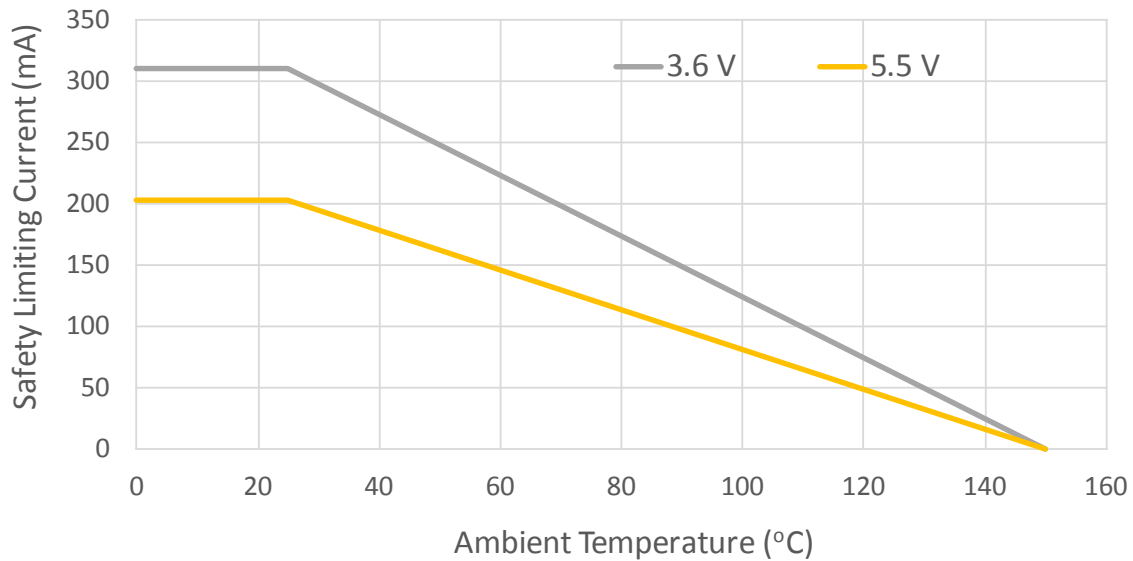

Figure 4.3. NB SOIC-8 Thermal Derating Curve for Safety Limiting Current

Table 4.4. Absolute Maximum Ratings¹

Parameter	Symbol	Min	Max	Unit
Storage Temperature	T_{STG}	-65	150	°C
Ambient Temperature Under Bias	T_A	-40	125	°C
Junction Temperature	T_J	—	150	°C
Supply Voltage	VDDA, VDDDB	-0.5	6.0	V
Input Voltage respect to GNDA	VIN	-0.5	VDDA + 0.5	V
Output Sink or Source Current	I _o	—	5	mA
Total Power Dissipation	P _T	—	212	mW
Lead Solder Temperature (10 s)		—	260	°C
Human Body Model ESD Rating		6000	—	V
Capacitive Discharge Model ESD Rating		2000	—	V
Maximum Isolation (WB Stretched SOIC-8 Input to Output) (1 s)		—	6500	V _{RMS}
Maximum Isolation (NB SOIC-8 package Input to Output) (1 s)		—	4500	V _{RMS}

Note:

1. Permanent device damage may occur if the absolute maximum ratings are exceeded. Functional operation should be restricted to conditions as specified in the operational sections of the data sheet.

4.1 Regulatory Information

Table 4.5. Regulatory Information (Pending)^{1, 2}

CSA
The Si8931/32 is certified under CSA. For more details, see Master Contract File 232873.
60950-1, 62368-1: Up to 600 V _{RMS} reinforced insulation working voltage; up to 1000 V _{RMS} basic insulation working voltage.
VDE
The Si8931/32 is certified according to VDE 0884-11. For more details, see File 5006301-4880-0001.
VDE 0884-11: Up to 1414 V _{peak} for reinforced insulation working voltage.
UL
The Si8931/32 is certified under UL1577 component recognition program. For more details, see File E257455.
Rated up to 5000 V _{RMS} isolation voltage for basic protection.
CQC
The Si8931/32 is certified under GB4943.1-2011.
Rated up to 600 V _{RMS} reinforced insulation working voltage; up to 1000 V _{RMS} basic insulation working voltage.
Note:
1. Regulatory Certifications apply to 5 kV _{RMS} rated devices which are production tested to 6.0 kV _{RMS} for 1 sec.
2. Regulatory Certifications apply to 2.5 kVRMS rated devices which are production tested to 3.0 kVRMS for 1 sec.

Table 4.6. Insulation and Safety-Related Specifications

Parameter	Symbol	Test Condition	Value		Unit
			WB Stretched SOIC-8	NB SOIC-8	
Nominal External Air Gap (Clearance)	CLR		9.0 ¹	4.9	mm
Nominal External Tracking (Creepage)	CPG		8.0 ¹	4.01	mm
Minimum Internal Gap (Internal Clearance)	DTI		36	36	μm
Tracking Resistance	PTI or CTI	IEC60112	600	600	V
Erosion Depth	ED		0.04	0.04	mm
Resistance (Input-Output) ²	R _{IO}		10 ¹²	10 ¹²	Ω
Capacitance (Input-Output) ²	C _{IO}	f = 1 MHz	1	1	pF
Note:					
1. The values in this table correspond to the nominal creepage and clearance values. VDE certifies the clearance and creepage limits as x.x mm minimum for the WB Stretched SOIC-8 package. UL does not impose a clearance and creepage minimum for component-level certifications. CSA certifies the clearance and creepage limits as x.x mm minimum for the WB Stretched SOIC-8 package.					
2. To determine resistance and capacitance, the Si8931/32 is converted into a two-terminal device. Pins 1–4 are shorted together to form the first terminal, and pins 5–8 are shorted together to form the second terminal. The parameters are then measured between these two terminals.					

Table 4.7. IEC 60664-1 Ratings

Parameter	Test Conditions	Specification	
		WB Stretched SOIC-8	NB SOIC-8
Basic Isolation Group	Material Group	I	I
Installation Classification	Rated Mains Voltages $\leq 150 V_{RMS}$	I-IV	I-IV
	Rated Mains Voltages $\leq 300 V_{RMS}$	I-IV	I-IV
	Rated Mains Voltages $\leq 600 V_{RMS}$	I-IV	I-III

Table 4.8. VDE 0884-11 Insulation Characteristics¹

Parameter	Symbol	Test Condition	Characteristic		Unit
			WB Stretched SOIC-8	NB SOIC-8	
Maximum Working Insulation Voltage	V_{IORM}		1414	560	V peak
Input to Output Test Voltage	V_{PR}	Method b1 ($V_{IORM} \times 1.875 = V_{PR}$, 100% Production Test, $t_m = 1$ sec, Partial Discharge < 5 pC)	2650	1050	V peak
Transient Overvoltage	V_{IOTM}	$t = 60$ sec	8000	4000	V peak
Surge Voltage	V_{IOSM}	Tested per IEC 60065 with surge voltage using rise/decay time of 1.2 μ s/50 μ s	6250 (Tested with 10 kV)	6250 (Tested with 10 kV)	V peak
Pollution Degree (DIN VDE 0110, Table 1)			2	2	
Insulation Resistance at T_S , $V_{IO} = 500$ V	R_S		$>10^9$	$>10^9$	Ω

Note:

1. This isolator is suitable for reinforced electrical isolation only within the safety limit data. Maintenance of the safety data is ensured by protective circuits. The Si8931/32 provides a climate classification of 40/125/21.

4.2 Typical Operating Characteristics

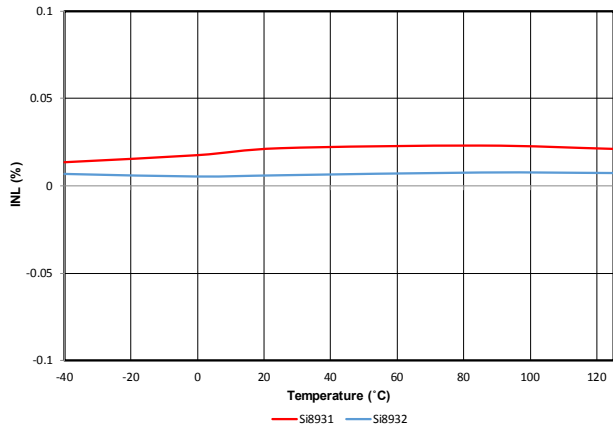

Figure 4.4. Nonlinearity (%) vs. Temperature (°C)

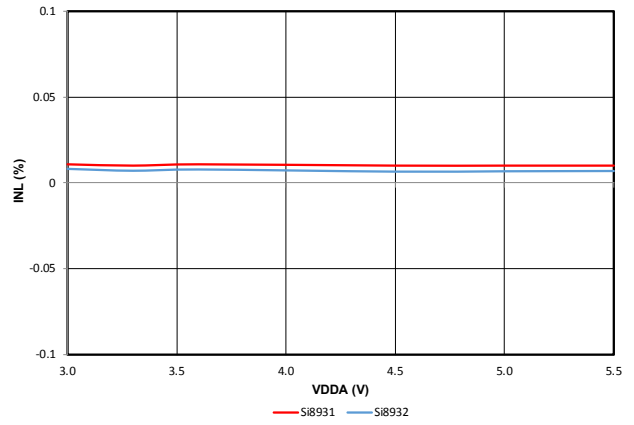

Figure 4.5. Nonlinearity (%) vs. VDDA Supply (V)

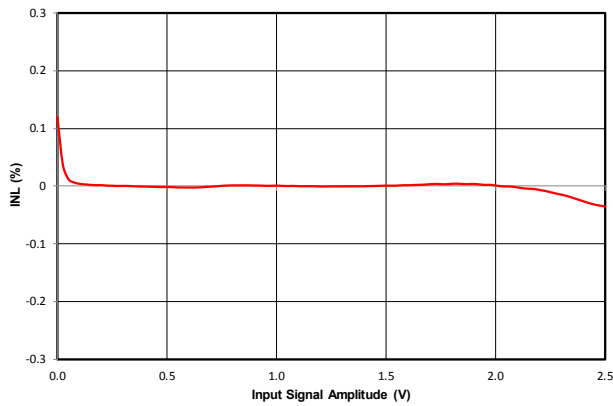

Figure 4.6. Si8931 Nonlinearity (%) vs. Input Signal Amplitude (mV)

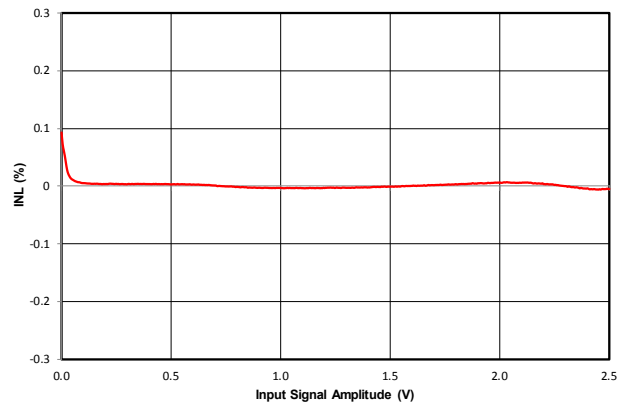

Figure 4.7. Si8932 Nonlinearity (%) vs. Input Signal Amplitude (mV)

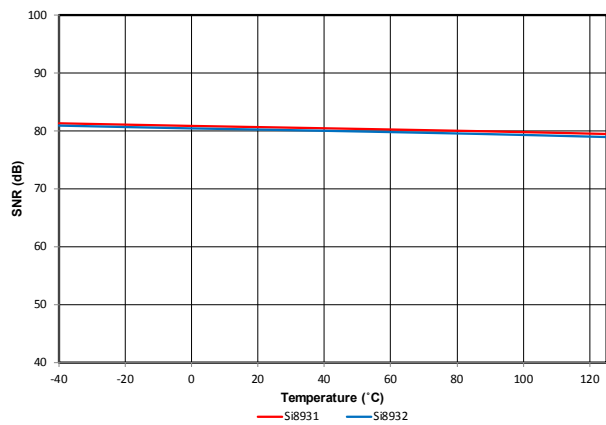

Figure 4.8. Signal-to-Noise Ratio (dB) vs. Temperature (°C)

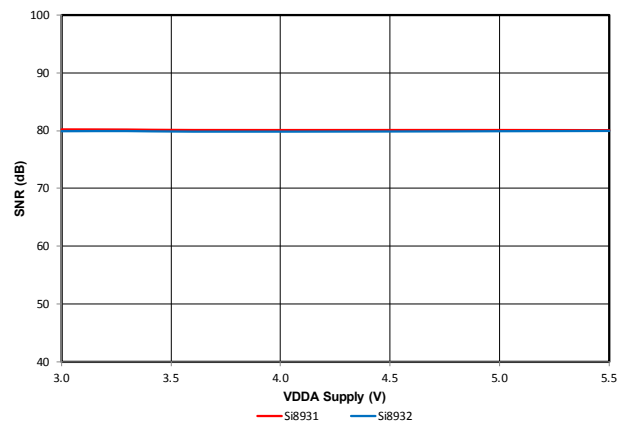

Figure 4.9. Signal-to-Noise Ratio (dB) vs. VDDA Supply (V)

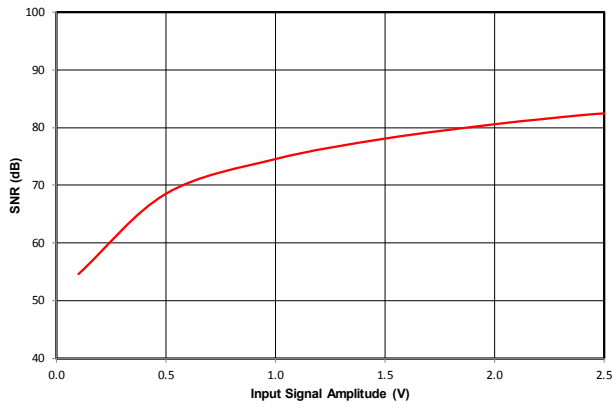

Figure 4.10. Si8931 Signal-to-Noise Ratio (dB) vs. Input Signal Amplitude (V)

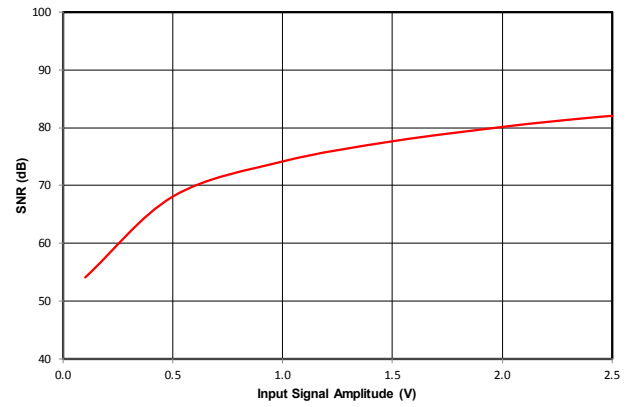

Figure 4.11. Si8932 Signal-to-Noise Ratio (dB) vs. Input Signal Amplitude (V)

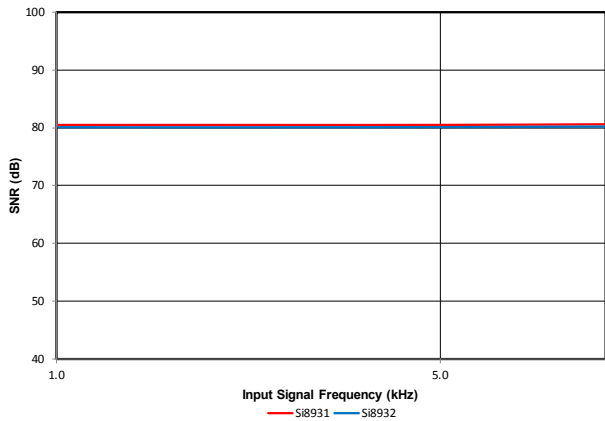

Figure 4.12. Signal-to-Noise Ratio (dB) vs. Input Signal Frequency (kHz)

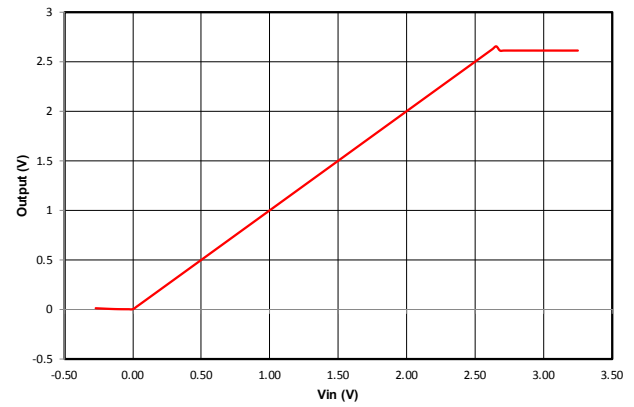

Figure 4.13. Output Voltage (V) vs. Input Voltage (V)

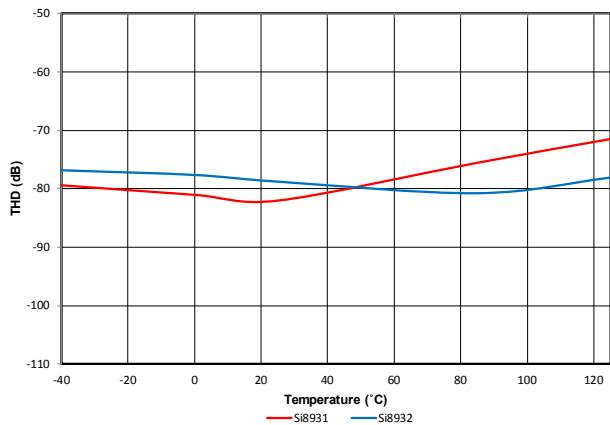

Figure 4.14. Total Harmonic Distortion (dB) vs. Temperature (°C)

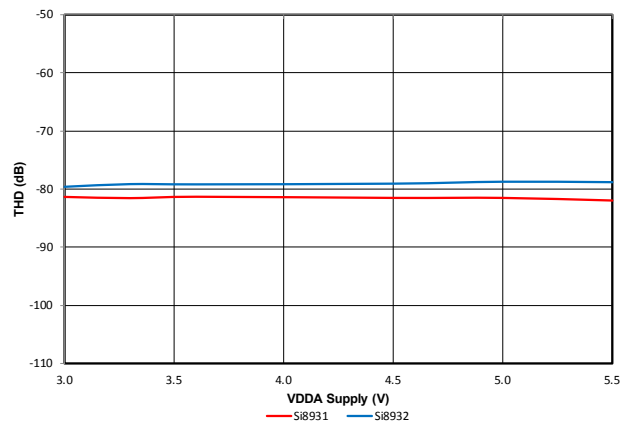

Figure 4.15. Total Harmonic Distortion (dB) vs. VDDA Supply (V)

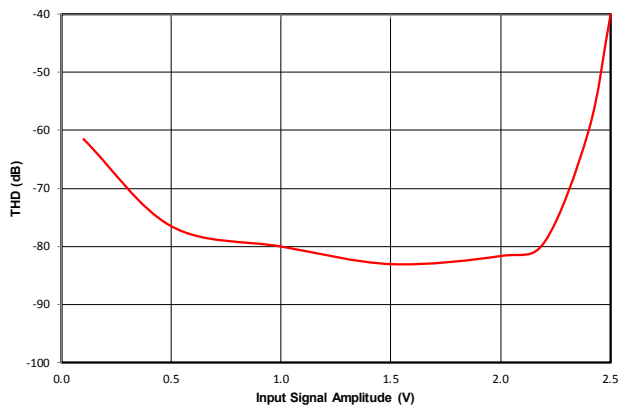

Figure 4.16. Si8931 Total Harmonic Distortion (dB) vs. Input Signal Amplitude (V)

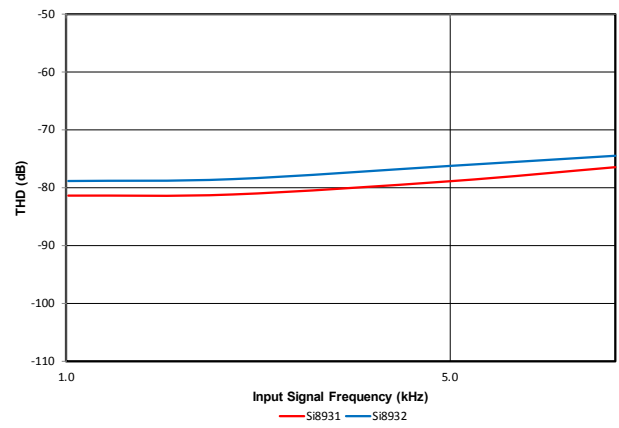

Figure 4.17. Total Harmonic Distortion (dB) vs. Input Signal Frequency (kHz)

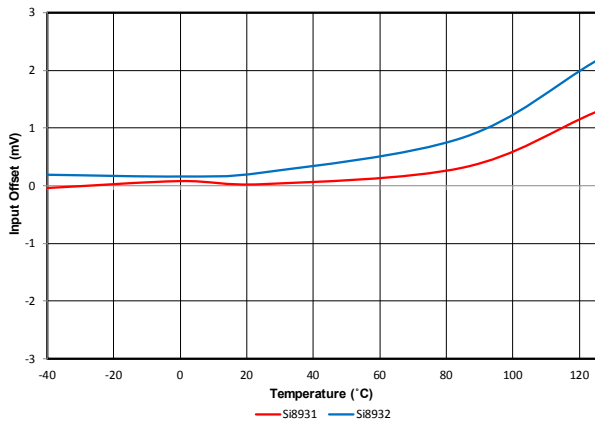

Figure 4.18. Input Offset (mV) vs. Temperature (°C)

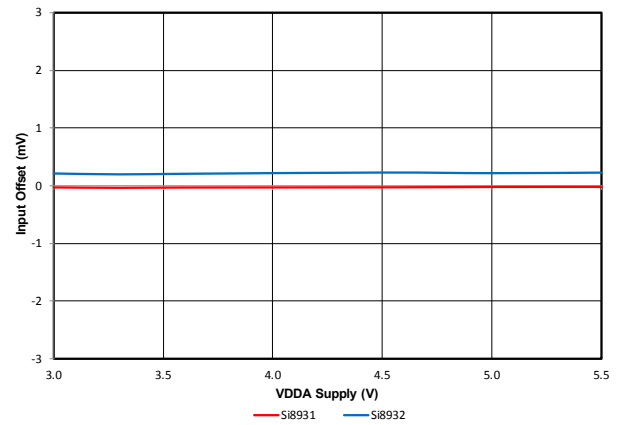

Figure 4.19. Input Offset (mV) vs. VDDA Supply (V)

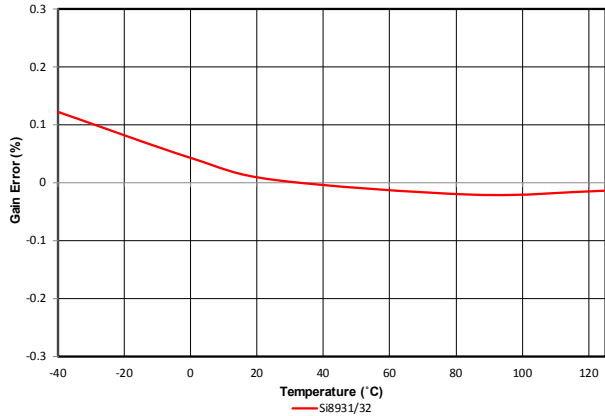

Figure 4.20. Gain Error (%) vs. Temperature (°C)

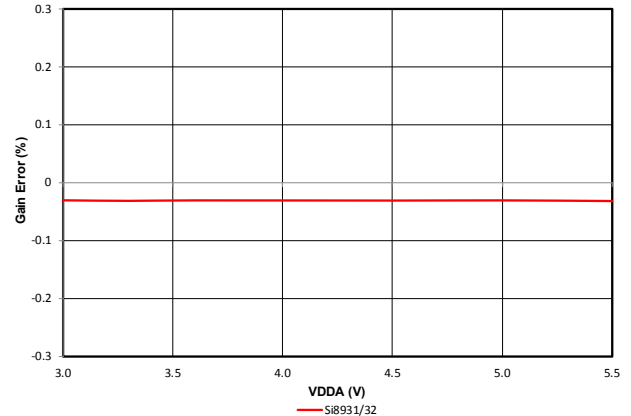

Figure 4.21. Gain Error (%) vs. VDDA Supply (V)

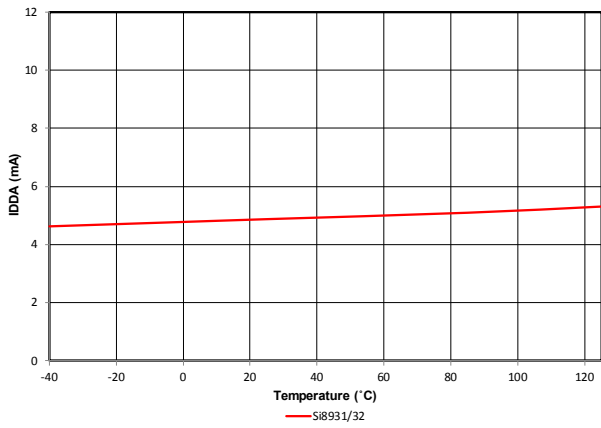

Figure 4.22. IDDA (mA) vs. Temperature (°C)

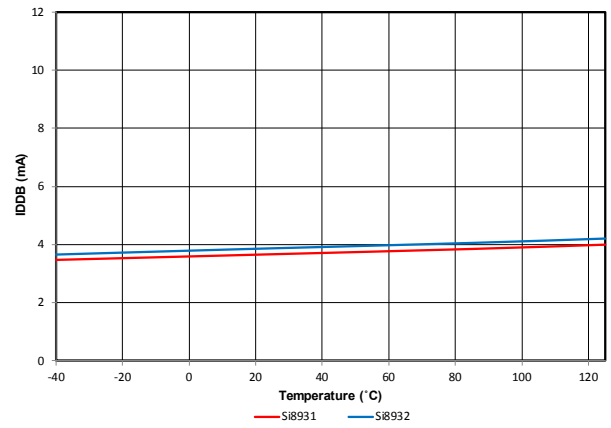

Figure 4.23. IDDB (mA) vs. Temperature (°C)

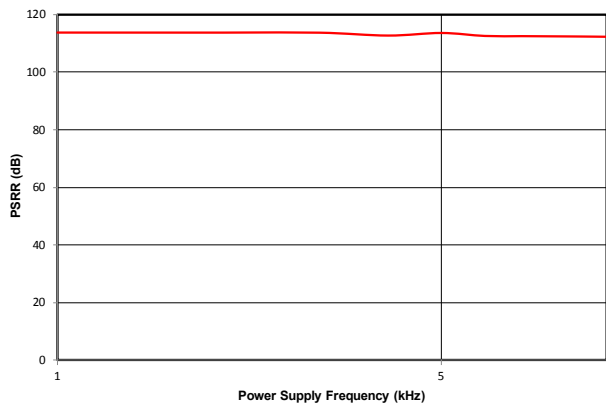

Figure 4.24. PSRR (dB) vs. Power Supply Frequency (kHz)

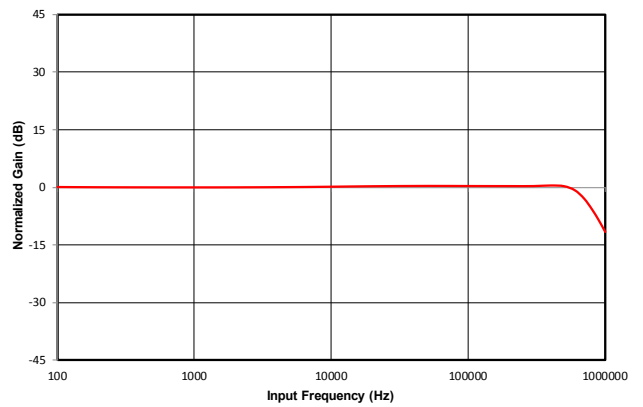

Figure 4.25. Amplifier Bandwidth

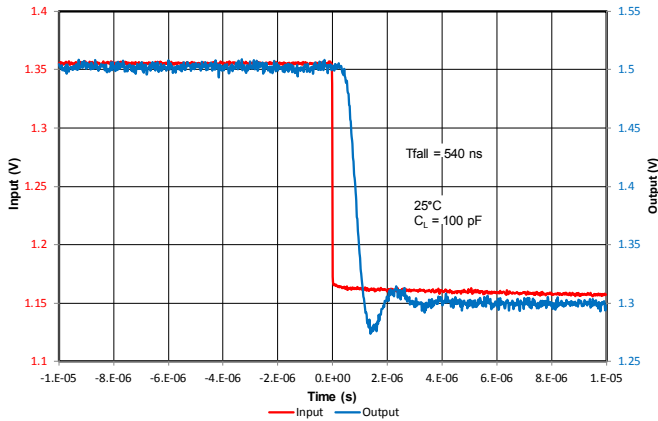

Figure 4.26. Si8931 High-to-Low Step Response

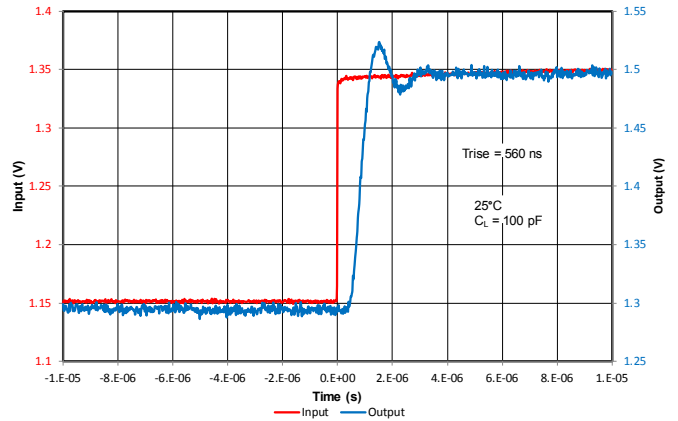

Figure 4.27. Si8931 Low-to-High Step Response

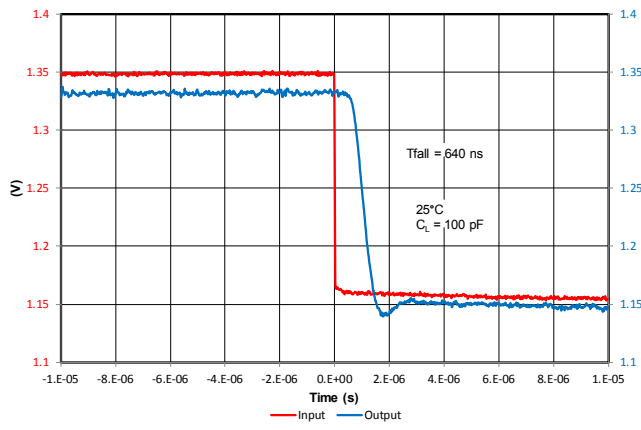

Figure 4.28. Si8932 High-to-Low Step Response

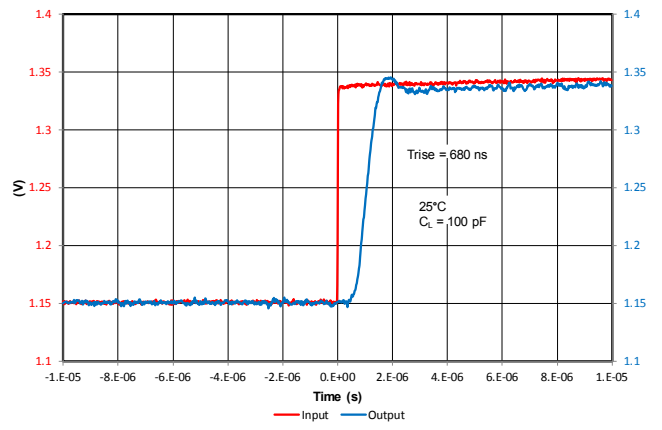

Figure 4.29. Si8932 Low-to-High Step Response

5. Pin Descriptions

5.1 Si8931 Pin Descriptions

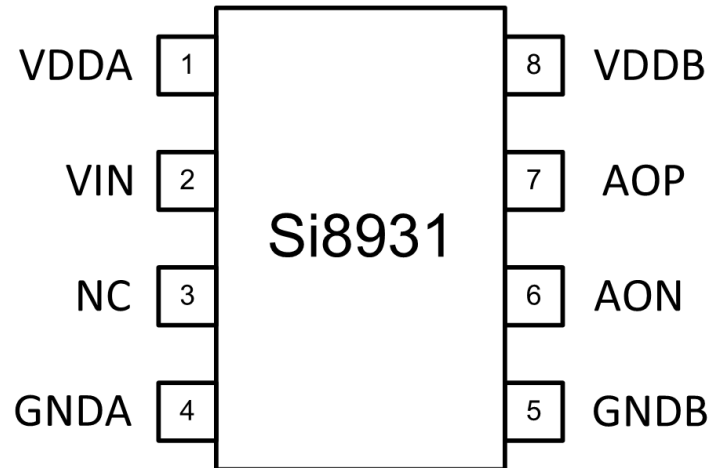

Table 5.1. Si8931 Pin Descriptions

Name	Pin Number	Description
VDDA	1	Input side power supply
VIN	2	Voltage input
NC ¹	3	No Connect
GNDA	4	Input side ground
GNDB	5	Output side ground
AON	6	Analog output low
AOP	7	Analog output high
VDDB	8	Output side power supply

Note:

1. No Connect. These pins are not internally connected. To maximize CMTI performance, these pins should be connected to the ground plane.

5.2 Si8932 Pin Descriptions

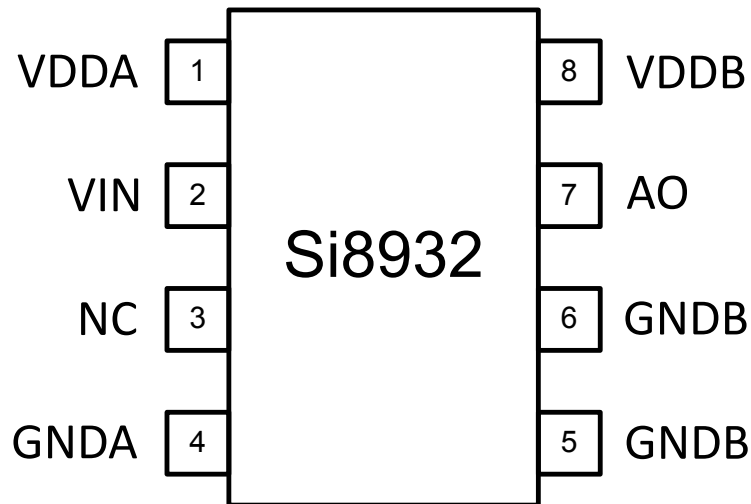

Table 5.2. Si8932 Pin Descriptions

Name	Pin Number	Description
VDDA	1	Input side power supply
VIN	2	Voltage input
NC ¹	3	No Connect
GNDA	4	Input side ground
GNDB	5	Output side ground
GNDB	6	Output side ground
AO	7	Analog output
VDDB	8	Output side power supply

Note:

1. No Connect. These pins are not internally connected. To maximize CMTI performance, these pins should be connected to the ground plane.

6. Packaging

6.1 Package Outline: 8-Pin Wide Body Stretched SOIC

The figure below illustrates the package details for the Si8931/32 in a 8-Pin Wide Body Stretched SOIC package. The table lists the values for the dimensions shown in the illustration.

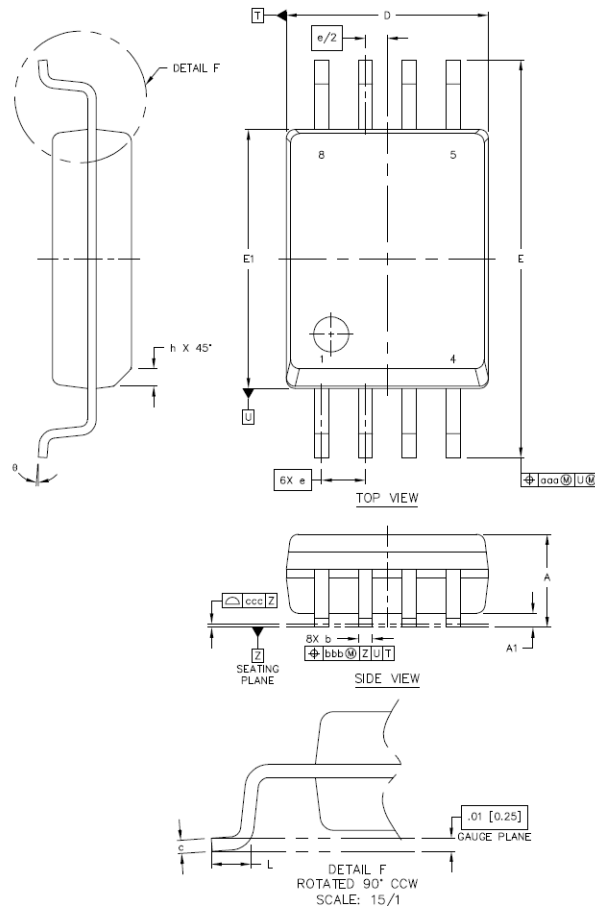

Figure 6.1. 8-Pin Wide Body Stretched SOIC Package

Table 6.1. 8-Pin Wide Body Stretched SOIC Package Diagram Dimensions

Symbol	Millimeters	
	Min	Max
A	2.49	2.79
A1	0.36	0.46
b	0.30	0.51
c	0.20	0.33
D	5.74	5.94
E	11.25	11.76
E1	7.39	7.59
e	1.27 BSC	
L	0.51	1.02
h	0.25	0.76

Symbol	Millimeters	
	Min	Max
θ	0°	8°
aaa	—	0.25
bbb	—	0.25
ccc	—	0.10

Note:

1. All dimensions shown are in millimeters (mm) unless otherwise noted.
2. Dimensioning and Tolerancing per ANSI Y14.5M-1994.
3. Recommended reflow profile per JEDEC J-STD-020C specification for small body, lead-free components.

6.2 Package Outline: 8-Pin Narrow Body SOIC

The figure below illustrates the package details for the Si8931/32 in an 8-Pin Narrow Body SOIC package. The table lists the values for the dimensions shown in the illustration.

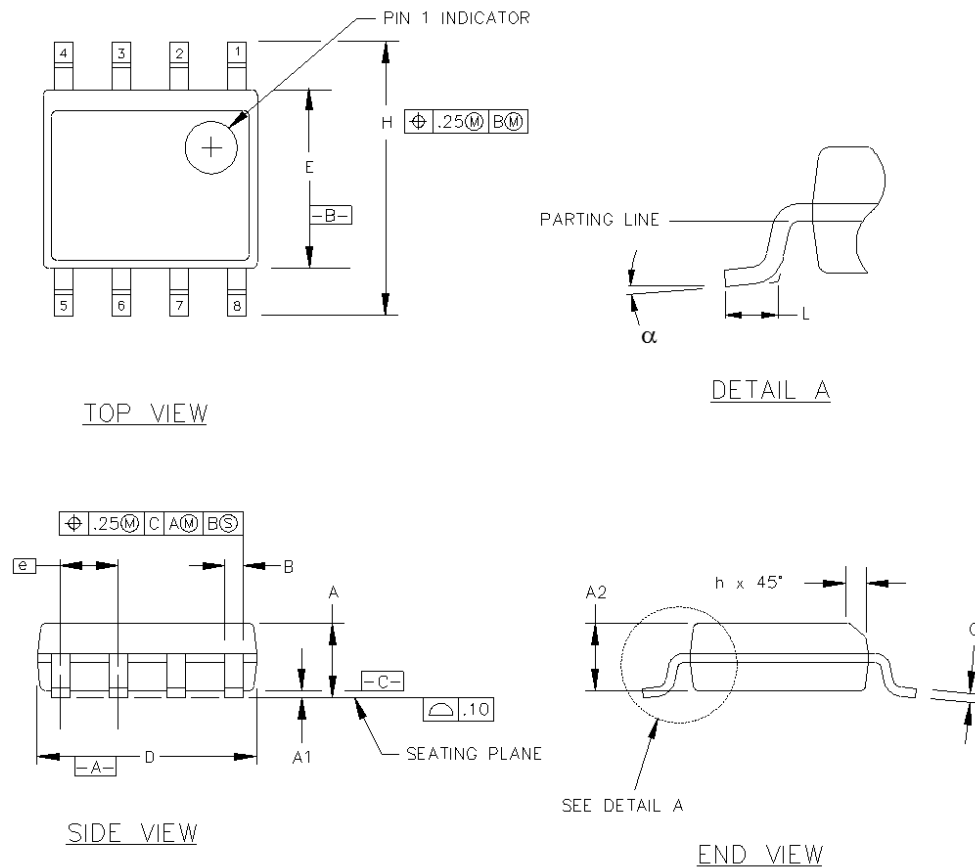

Figure 6.2. 8-Pin Narrow Body SOIC Package

Table 6.2. 8-Pin Narrow Body SOIC Package Diagram Dimensions

Dimension	Min	Max
A	1.35	1.75
A1	0.10	0.25
A2	1.40 REF	1.55 REF
B	0.33	0.51
C	0.19	0.25
D	4.80	5.00
E	3.80	4.00
e	1.27 BSC	
H	5.80	6.20
h	0.25	0.50
L	0.40	1.27
α	0°	8°

Dimension	Min	Max
<p>Note:</p> <ol style="list-style-type: none">1. All dimensions shown are in millimeters (mm) unless otherwise noted.2. Dimensioning and Tolerancing per ANSI Y14.5M-1982.3. This drawing conforms to JEDEC Outline MS-012.4. Recommended card reflow profile is per the JEDEC/IPC J-STD-020B specification for Small Body Components.		

6.3 Land Pattern: 8-Pin Wide Body Stretched SOIC

The figure below illustrates the recommended land pattern details for the Si8931/32 in a 8-Pin Wide Body Stretched SOIC package. The table lists the values for the dimensions shown in the illustration.

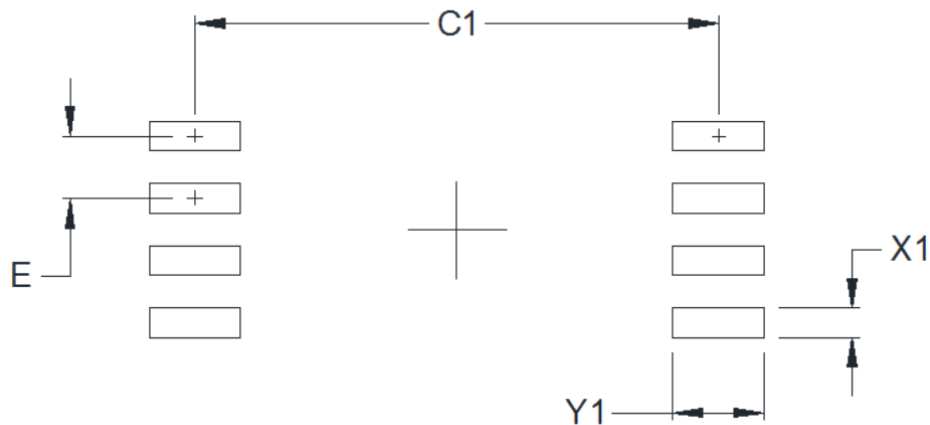

Figure 6.3. 8-Pin Wide Body Stretched SOIC Land Pattern

Table 6.3. 8-Pin Wide Body Stretched SOIC Land Pattern Dimensions¹

Dimension	(mm)
C1	10.60
E	1.27
X1	0.60
Y1	1.85

Note:

General

1. All dimensions shown are at Maximum Material Condition (MMC). Least Material Condition (LMC) is calculated based on a Fabrication Allowance of 0.05mm.
2. This Land Pattern Design is based on the IPC-7351 guidelines.

Solder Mask Design

1. All metal pads are to be non-solder mask defined (NSMD). Clearance between the solder mask and the metal pad is to be 60 μm minimum, all the way around the pad.

Stencil Design

1. A stainless steel, laser-cut and electro-polished stencil with trapezoidal walls should be used to assure good solder paste release.
2. The stencil thickness should be 0.125mm (5 mils).
3. The ratio of stencil aperture to land pad size should be 1:1 for all perimeter pins.

Card Assembly

1. A No-Clean, Type-3 solder paste is recommended.
2. The recommended card reflow profile is per the JEDEC/IPC J-STD-020 specification for Small Body Components.

6.4 Land Pattern: 8-Pin Narrow Body SOIC

The figure below illustrates the recommended land pattern details for the Si8931/32 in an 8-Pin Narrow Body SOIC package. The table lists the values for the dimensions shown in the illustration.

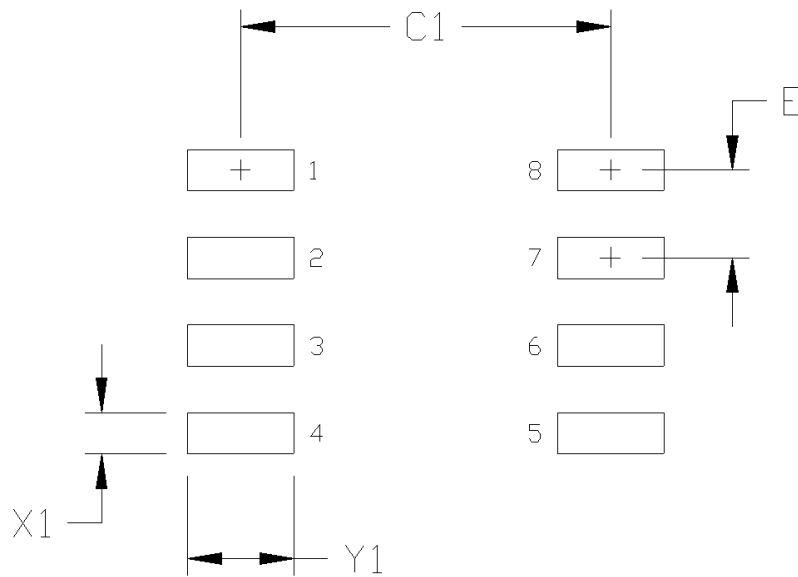

Figure 6.4. 8-Pin Narrow Body SOIC Land Pattern

Table 6.4. 8-Pin Narrow Body SOIC Land Pattern Dimensions

Symbol	mm
C1	5.40
E	1.27
X1	0.60
Y1	1.55

Note:

1. This Land Pattern Design is based on IPC-7351 pattern SOIC127P600X173-8N for Density Level B (Median Land Protrusion).
2. All feature sizes shown are at Maximum Material Condition (MMC) and a card fabrication tolerance of 0.05 mm is assumed.

6.5 Top Marking: 8-Pin Wide Body Stretched SOIC

The figure below illustrates the top markings for the Si8931/32 in a 8-Pin Wide Body Stretched SOIC package. The table explains the top marks shown in the illustration.

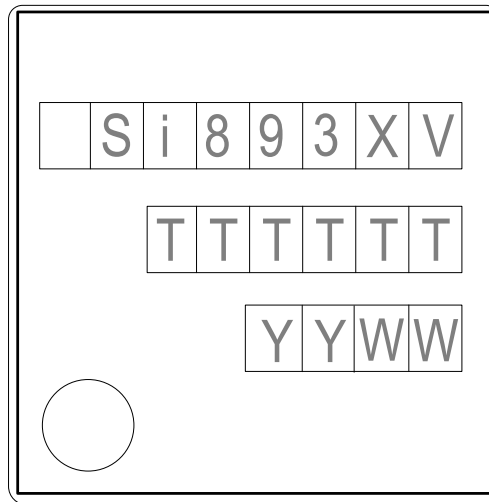

Figure 6.5. 8-Pin Wide Body Stretched SOIC Top Marking

Table 6.5. 8-Pin Wide Body Stretched SOIC Top Mark Explanation

Line 1 Marking:	Customer Part Number	Si893X X = Base part number • 1 = Differential output • 2 = Single-ended output V = Insulation rating: • D = 5.0 kVrms
Line 2 Marking:	TTTTTT = Mfg Code	Manufacturing Code from the Assembly Purchase Order form.
Line 3 Marking:	YY = Year WW = Work Week Circle = 43 mils Diameter Left-Justified	Assigned by the Assembly House. Corresponds to the year and work week of the mold date.

6.6 Top Marking: 8-Pin Narrow Body SOIC

The figure below illustrates the top markings for the Si8931/32 in an 8-Pin Narrow Body SOIC package. The table explains the top marks shown in the illustration.

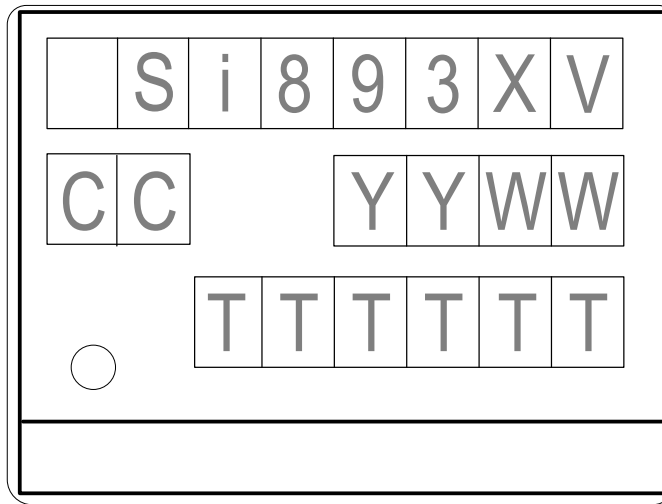

Figure 6.6. 8-Pin Narrow Body SOIC Top Marking

Table 6.6. 8-Pin Narrow Body SOIC Top Marking Explanation

Line 1 Marking:	Customer Part Number	<p>Si893X = Isolator Amplifier Series</p> <p>X = Base part number</p> <ul style="list-style-type: none"> • 1 = Differential output • 2 = Single-ended output <p>S = Input Range:</p> <ul style="list-style-type: none"> • A = ± 62.5 mV • B = ± 250 mV <p>V = Insulation rating:</p> <ul style="list-style-type: none"> • B = 2.5 kVrms
Line 2 Marking:	<p>CC = Country of Origin ISO Code Abbreviation</p> <p>YY = Year</p> <p>WW = Work Week</p>	Assigned by the Assembly House. Corresponds to the year and work week of the mold date.
Line 3 Marking:	<p>TTTTTT = Mfg Code</p> <p>Circle = 19.7 mils Diameter</p> <p>Left-Justified</p>	Manufacturing Code from the Assembly Purchase Order form.

7. Revision History

Revision 0.8

May, 2021

- Added Automotive OPNs to [1. Ordering Guide](#).
- Updated [Figure 3.1 Voltage Sense Application](#) on page 6.
- Updated [Table 4.4 Absolute Maximum Ratings¹](#) on page 11.
- Added Surge Voltage parameter to [Table 4.8 VDE 0884-11 Insulation Characteristics¹](#) on page 13.
- Changed "60 mm" to "60 μ m" in Solder Mask Design note in [Table 6.3 8-Pin Wide Body Stretched SOIC Land Pattern Dimensions¹](#) on page 25.

Revision 0.7

December, 2019

- Updated Applications and Key Features on front page.
- Updated [4. Electrical Specifications](#) after full characterization.
- Added section for Automotive Grade OPNs.
- Updated [Table 4.6 Insulation and Safety-Related Specifications](#) on page 12.
- Updated [6.6 Top Marking: 8-Pin Narrow Body SOIC](#).
- Changed Si8932 Pin 6 from NC to GND.
- Numerous clarifications throughout.

Revision 0.5

March, 2019

- Updated specifications.
- Added narrow body SOIC-8 package.

Revision 0.2

May, 2018

- Corrections and clarifications.

Revision 0.1

January, 2018

- Initial draft.



SKYWORKS®

**Connecting Everyone
and Everything,
All the Time**



Portfolio

www.skyworksinc.com

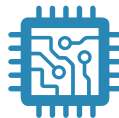

Quality

www.skyworksinc.com/quality



Support & Resources

www.skyworksinc.com/support

Copyright © 2021 Skyworks Solutions, Inc. All Rights Reserved.

Information in this document is provided in connection with Skyworks Solutions, Inc. ("Skyworks") products or services. These materials, including the information contained herein, are provided by Skyworks as a service to its customers and may be used for informational purposes only by the customer. Skyworks assumes no responsibility for errors or omissions in these materials or the information contained herein. Skyworks may change its documentation, products, services, specifications or product descriptions at any time, without notice. Skyworks makes no commitment to update the materials or information and shall have no responsibility whatsoever for conflicts, incompatibilities, or other difficulties arising from any future changes.

No license, whether express, implied, by estoppel or otherwise, is granted to any intellectual property rights by this document. Skyworks assumes no liability for any materials, products or information provided hereunder, including the sale, distribution, reproduction or use of Skyworks products, information or materials, except as may be provided in Skyworks' Terms and Conditions of Sale.

THE MATERIALS, PRODUCTS AND INFORMATION ARE PROVIDED "AS IS" WITHOUT WARRANTY OF ANY KIND, WHETHER EXPRESS, IMPLIED, STATUTORY, OR OTHERWISE, INCLUDING FITNESS FOR A PARTICULAR PURPOSE OR USE, MERCHANTABILITY, PERFORMANCE, QUALITY OR NON-INFRINGEMENT OF ANY INTELLECTUAL PROPERTY RIGHT; ALL SUCH WARRANTIES ARE HEREBY EXPRESSLY DISCLAIMED. SKYWOKS DOES NOT WARRANT THE ACCURACY OR COMPLETENESS OF THE INFORMATION, TEXT, GRAPHICS OR OTHER ITEMS CONTAINED WITHIN THESE MATERIALS. SKYWOKS SHALL NOT BE LIABLE FOR ANY DAMAGES, INCLUDING BUT NOT LIMITED TO ANY SPECIAL, INDIRECT, INCIDENTAL, STATUTORY, OR CONSEQUENTIAL DAMAGES, INCLUDING WITHOUT LIMITATION, LOST REVENUES OR LOST PROFITS THAT MAY RESULT FROM THE USE OF THE MATERIALS OR INFORMATION, WHETHER OR NOT THE RECIPIENT OF MATERIALS HAS BEEN ADVISED OF THE POSSIBILITY OF SUCH DAMAGE.

Skyworks products are not intended for use in medical, lifesaving or life-sustaining applications, or other equipment in which the failure of the Skyworks products could lead to personal injury, death, physical or environmental damage. Skyworks customers using or selling Skyworks products for use in such applications do so at their own risk and agree to fully indemnify Skyworks for any damages resulting from such improper use or sale.

Customers are responsible for their products and applications using Skyworks products, which may deviate from published specifications as a result of design defects, errors, or operation of products outside of published parameters or design specifications. Customers should include design and operating safeguards to minimize these and other risks. Skyworks assumes no liability for applications assistance, customer product design, or damage to any equipment resulting from the use of Skyworks products outside of Skyworks' published specifications or parameters.

Skyworks, the Skyworks symbol, Sky5®, SkyOne®, SkyBlue™, Skyworks Green™, Clockbuilder®, DSPLL®, ISOModem®, ProSLIC®, and SiPHY® are trademarks or registered trademarks of Skyworks Solutions, Inc. or its subsidiaries in the United States and other countries. Third-party brands and names are for identification purposes only and are the property of their respective owners. Additional information, including relevant terms and conditions, posted at www.skyworksinc.com, are incorporated by reference.

Skyworks Solutions, Inc. | Nasdaq: SWKS | sales@skyworksinc.com | www.skyworksinc.com

USA: 781-376-3000 | Asia: 886-2-2735 0399 | Europe: 33 (0)1 43548540 |

X-ON Electronics

Largest Supplier of Electrical and Electronic Components

Click to view similar products for [Isolation Amplifiers](#) category:

Click to view products by [Skyworks](#) manufacturer:

Other Similar products are found below :

[AD202JN](#) [AD202JY](#) [AD204JY](#) [AD204KN](#) [ADUM3190TRQZ-RL7](#) [ADUM3190BRQZ](#) [ADUM3190ARQZ](#) [ADUM3190WSRQZ](#)
[ADUM4190ARIZ-RL](#) [ADUM4190BRIZ](#) [ADUM4190SRIZ](#) [AMC1100DUBR](#) [AMC1200BDUBR](#) [AMC1200BDWVR](#) [AMC1200SDUBR](#)
[AMC1200STDUBRQ1](#) [AMC1301DWVR](#) [AMC1311DWVR](#) [ISO124P](#) [AD204KY](#) [2902005](#) [AMC1300DWVR](#) [ISO121BG](#) [ISO121G](#)
[ISO124U1K](#)