

DATA SHEET

SKY13321-360LF: 0.1-3.0 GHz GaAs SPDT Switch

Applications

- Higher power applications with excellent linearity performance
- WiMAX systems

Features

- Positive voltage control (0 to 1.8 V)
- High isolation, 26 dB typical @ 1 GHz
- Low loss, 0.4 dB typical @ 1 GHz
- Excellent linearity performance, P-0.1dB insertion point @ +39 dBm
- Small, QFN (8-pin, 2 x 2 mm) package (MSL1, 260 °C per JEDEC J-STD-020)

NEW



Skyworks Green™ products are RoHS (Restriction of Hazardous Substances)-compliant, conform to the EIA/EICTA/JEITA Joint Industry Guide (JIG) Level A guidelines, are halogen free according to IEC-61249-2-21, and contain <1,000 ppm antimony trioxide in polymeric materials.

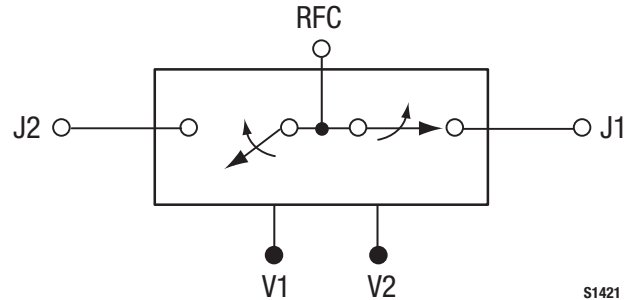

Figure 1. SKY13321-360LF Block Diagram

Description

The SKY13321-360LF is a pHEMT GaAs FET I/C switch. The switch may be used in transmit/receive applications by connecting the RF common port (RFC, pin 7) to either the J1 or J2 port (pin 1 or 4, respectively) using a low loss path (i.e., a positive voltage applied to either V1 or V2 pins).

The switch is manufactured in a compact, 2 x 2 mm, 8-pin exposed pad plastic Quad Flat No-Lead (QFN) package.

A functional block diagram is shown in Figure 1. The pin configuration and package are shown in Figure 2. Signal pin assignments and functional pin descriptions are provided in Table 1.

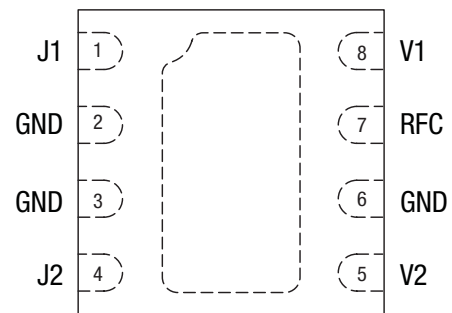

S1420

Figure 2. SKY13321-360LF Pinout – 8-Pin QFN (Top View)

Table 1. SKY13321-360LF Signal Descriptions

Pin #	Name	Description	Pin #	Name	Description
1	J1	RF port	5	V2	DC control voltage
2	GND	Ground	6	GND	Ground
3	GND	Ground	7	RFC	RF port
4	J2	RF port	8	V1	DC control voltage

Table 2. SKY13321-360LF Absolute Maximum Ratings

Parameter	Symbol	Minimum	Typical	Maximum	Units
Input power @ 900 MHz, 5 V @ 130 MHz, 5 V	P _{IN}			+40 +39	dBm dBm
Storage temperature	T _{STG}	-65		+150	°C
Operating temperature	T _{OP}	-40		+85	°C

Note: Exposure to maximum rating conditions for extended periods may reduce device reliability. There is no damage to device with only one parameter set at the limit and all other parameters set at or below their nominal value. Exceeding any of the limits listed here may result in permanent damage to the device.

CAUTION: Although this device is designed to be as robust as possible, Electrostatic Discharge (ESD) can damage this device. This device must be protected at all times from ESD. Static charges may easily produce potentials of several kilovolts on the human body or equipment, which can discharge without detection. Industry-standard ESD precautions should be used at all times.

Table 3. SKY13321-360LF Recommended Operating Conditions

Parameter	Symbol	Minimum	Typical	Maximum	Units
Frequency	f	0.1		3.0	GHz
Control voltage: low	V _{CTL_L}	0		0.2	V
high	V _{CTL_H}	1.8		5.0	V

Electrical and Mechanical Specifications

The absolute maximum ratings of the SKY13321-360LF are provided in Table 2. The recommended operating conditions are specified in Table 3 and electrical specifications are provided in Table 4.

Typical performance characteristics of the SKY13321-360LF are illustrated in Figures 3 through 8.

The state of the SKY13321-360LF is determined by the logic provided in Table 5.

Table 4. SKY13321-360LF Electrical Specifications (Note 1)**($V_{CTL} = 0\text{ V}$ and $+3\text{ V}$, $T_{OP} = +25\text{ }^{\circ}\text{C}$, $P_{IN} = 0\text{ dBm}$, Characteristic Impedance [Z_0] = $50\text{ }\Omega$, Unless Otherwise Noted)**

Parameter	Symbol	Test Condition	Min	Typical	Max	Units
Frequency	f		0.1		3.0	GHz
Insertion loss		0.1-1.0 GHz		0.40	0.50	dB
		1.0-2.0 GHz		0.50	0.60	dB
		2.0-2.5 GHz		0.55	0.70	dB
		2.5-3.0 GHz		0.60	0.80	dB
Isolation		0.1-1.0 GHz	23	26		dB
		1.0-2.0 GHz	17	20		dB
		2.0-2.5 GHz	15	18		dB
		2.5-3.0 GHz	13	16		dB
Return loss (insertion loss state)		0.1-3.0 GHz		25		dB
Switching characteristics:						
Rise/fall time		10/90% or 90/10% RF		650		ns
On/off time		50% V_{CTL} to 90/10% RF		800		ns
Input power for 0.1 dB compression		130 MHz		+39		dBm
		900 MHz		+39		dBm
		2450 MHz		+39		dBm
Second harmonic	2fo	$P_{IN} = +34.5\text{ dBm}$, f = 900 MHz		-75		dBc
		$P_{IN} = +32.0\text{ dBm}$, f = 1800 MHz		-70		dBc
		$P_{IN} = +36\text{ dBm}$, f = 350 to 470 MHz (UHF band),		-80		dBc
Third harmonic	3fo	$P_{IN} = +34.5\text{ dBm}$, f = 900 MHz		-75		dBc
		$P_{IN} = +32.0\text{ dBm}$, f = 1800 MHz		-70		dBc
		$P_{IN} = +36\text{ dBm}$, f = 350 to 470 MHz (UHF band)		-85		dBc
Blocker performance		Tone 1 = 1950 MHz @ +20 dBm, Tone 2 = 1760 MHz @ -15 dBm, IMD3 measured @ 2140 MHz		-105		dBm
Control voltage:						
Low	V_{CTL_L}		0		0.2	V
High	V_{CTL_H}		1.8		5.0	V
Control current	I_{CC}	$V_{CTL_H} = 5\text{ V}$		100		μA

Note 1: Performance is guaranteed only under the conditions listed in this Table.

Typical Performance Characteristics

($V_{CTL} = 0\text{ V}$ and $+3\text{ V}$, $T_{OP} = +25\text{ }^\circ\text{C}$, $P_{IN} = 0\text{ dBm}$, Characteristic Impedance [Z_0] = $50\ \Omega$, Blocking Capacitors = 100 pF , Bypass Capacitors = 33 pF , Unless Otherwise Noted)

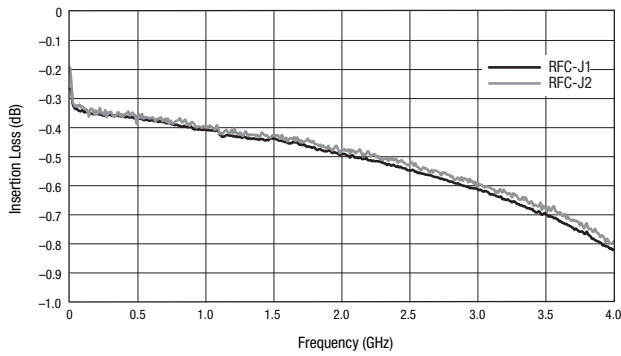

Figure 3. Typical Insertion Loss

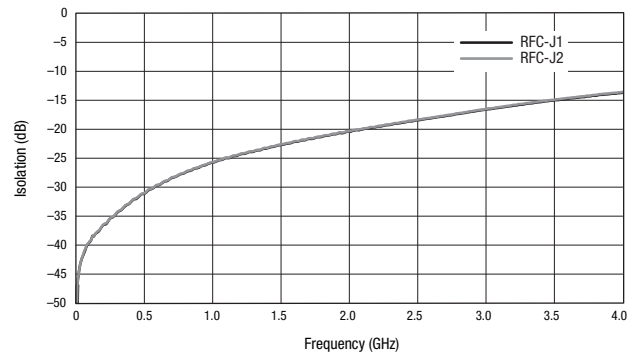

Figure 4. Typical Isolation

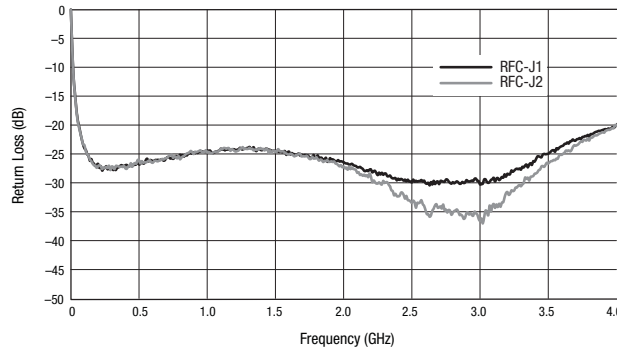

Figure 5. Typical Return Loss

Typical Performance Characteristics

(T_{OP} = +25 °C, Characteristic Impedance [Z₀] = 50 Ω, Unless Otherwise Noted)

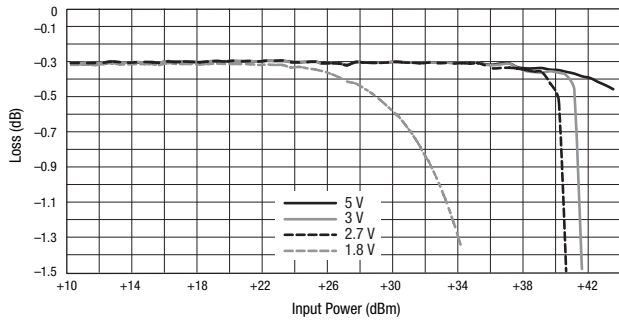

Figure 6. Typical 130 MHz Compression

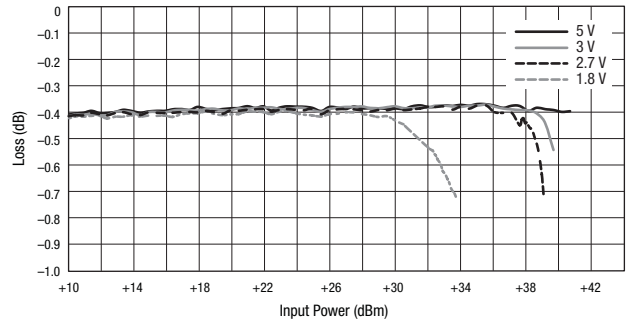

Figure 7. Typical 900 MHz Compression

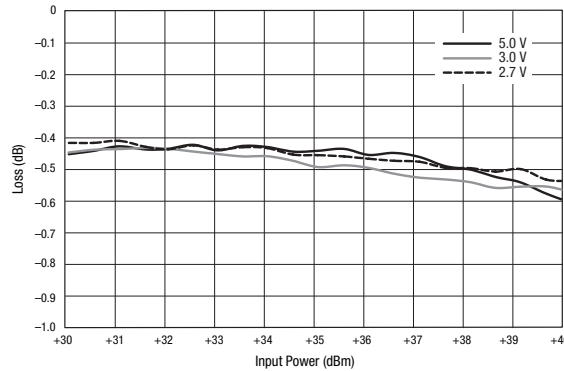

Figure 8. Typical 2450 MHz Compression

Table 5. SKY13321-360LF Truth Table

V1 (Pin 8)	V2 (Pin 5)	RFC to J1 Path	RFC to J2 Path
1	0	Insertion loss	Isolation
0	1	Isolation	Insertion loss

Note: "1" = +1.8 V to +5 V. "0" = 0 V. Any state other than described in this Table places the switch into an undefined state.

Evaluation Board Description

The SKY13321-360LF Evaluation Board is used to test the performance of the SKY13321-360LF SPDT Switch. An assembly drawing for the Evaluation Board is shown in Figure 9.

Package Dimensions

The PCB layout footprint for the SKY13321-360LF is provided in Figure 10. Typical case markings are shown in Figure 11. Package dimensions for the 4-pin QFN are shown in Figure 12, and tape and reel dimensions are provided in Figure 13.

Package and Handling Information

Instructions on the shipping container label regarding exposure to moisture after the container seal is broken must be followed. Otherwise, problems related to moisture absorption may occur when the part is subjected to high temperature during solder assembly.

THE SKY13321-360LF is rated to Moisture Sensitivity Level 1 (MSL1) at 260 °C. It can be used for lead or lead-free soldering.

Care must be taken when attaching this product, whether it is done manually or in a production solder reflow environment. Production quantities of this product are shipped in a standard tape and reel format.

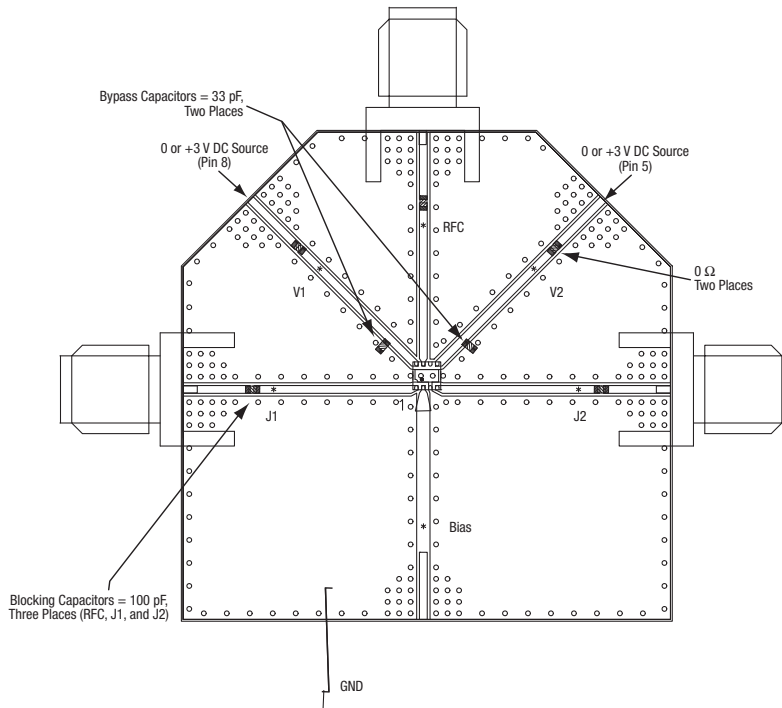

NOTE: A semi-universal Evaluation Board is used to test the SKY13321-360LF. Some RF lines are used to apply DC bias and have 0 Ω resistors installed. There are two RF bypass capacitors added to the DC control lines. The RF paths -- RFC, J1, and J2 -- have DC blocking capacitors installed.

S1476

Figure 9. SKY13321-360LF Evaluation Board Assembly Diagram

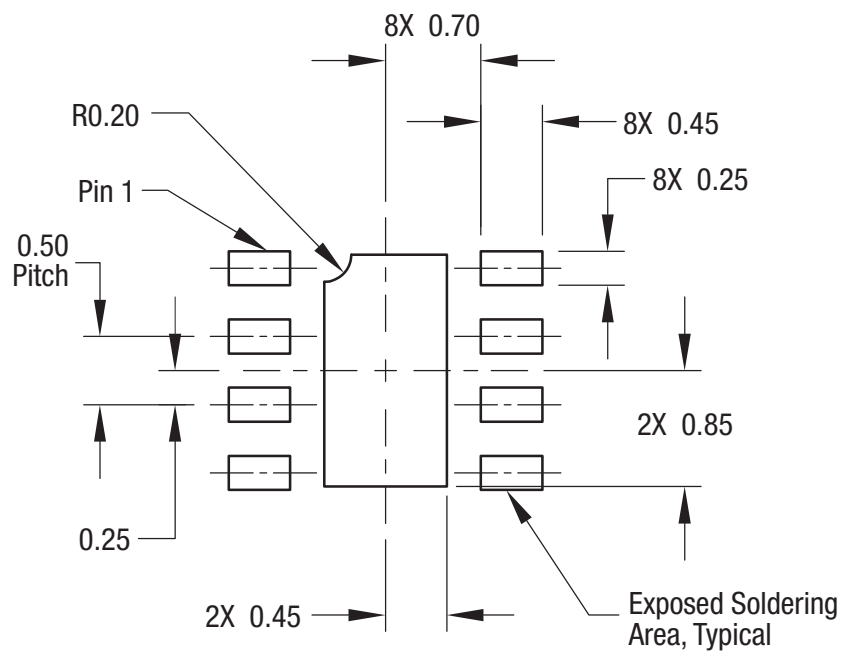

S1477

Figure 10. SKY13321-360LF PCB Layout Footprint

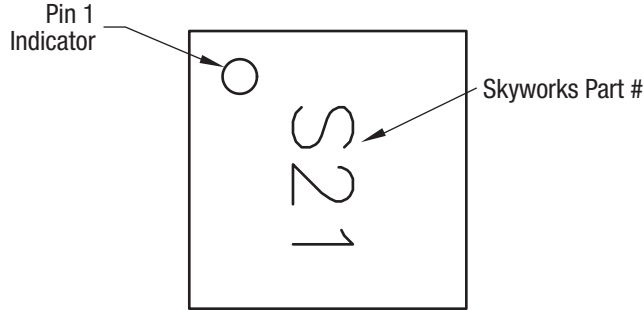
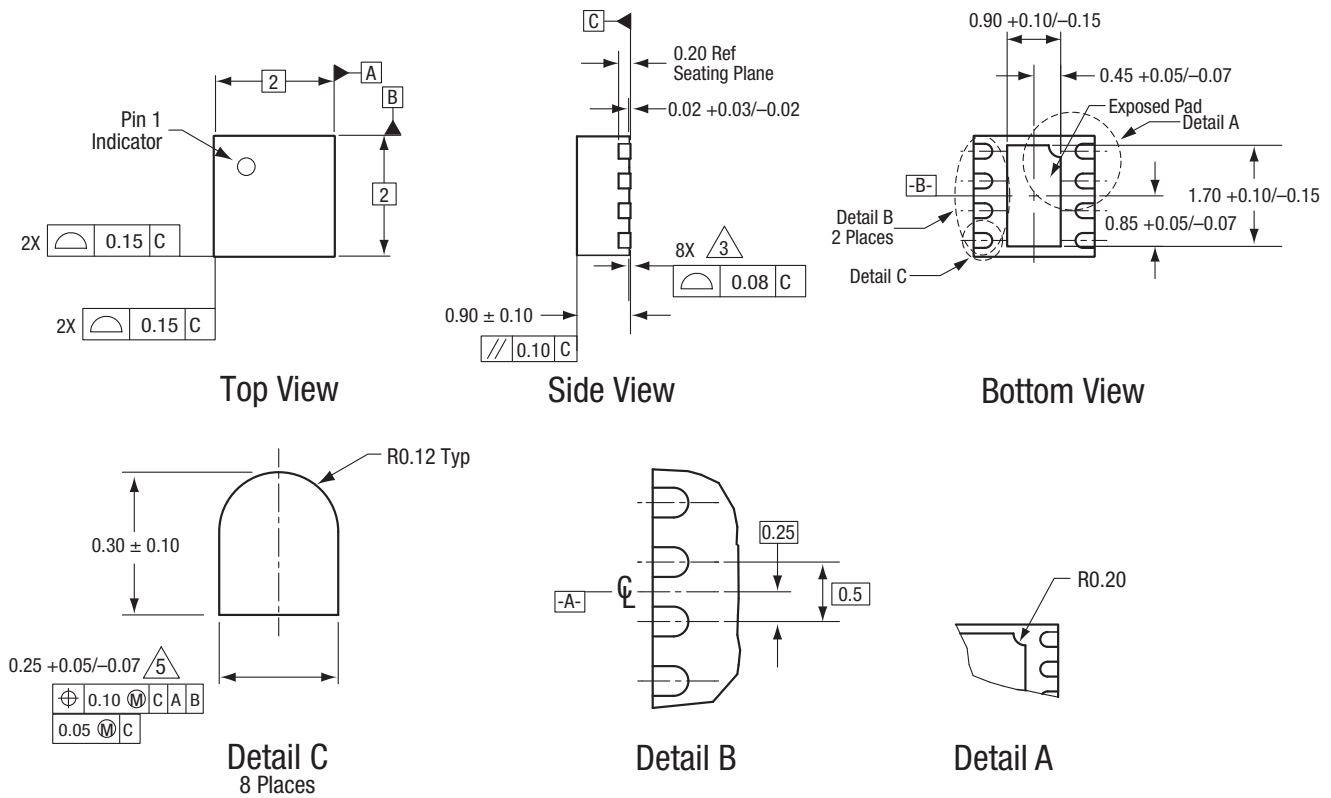

Figure 11. Typical Case Markings (Top View)



All measurements are in millimeters.
 Dimensioning and tolerancing according to ASME Y14.5M-1994.
 Coplanarity applies to the exposed heat sink slug as well as the terminals..
 Plating requirement per source control drawing (SCD) 2504.
 Dimension applies to metallized terminal and is measured between 0.15 mm and 0.30 mm from terminal tip.

S1415

Figure 12. SKY13321-360LF 8-Pin QFN Package Dimensions

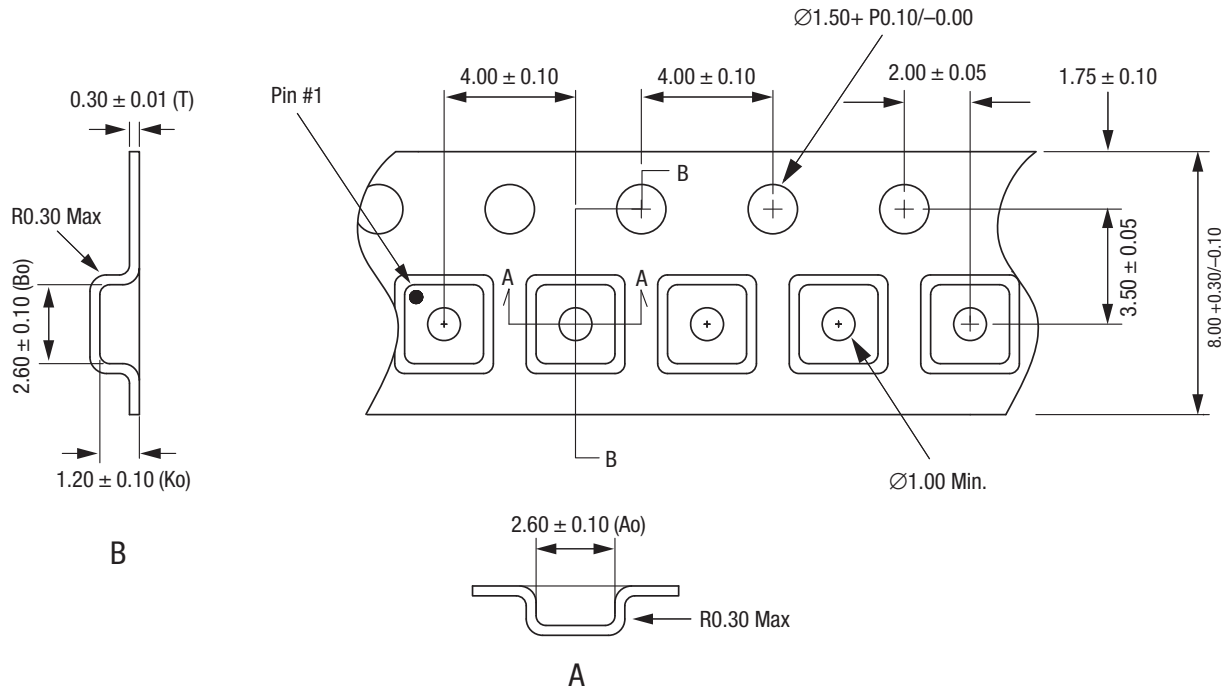

- Notes:
1. Carrier tape: black conductive polystyrene.
 2. Cover tape material: transparent conductive HSA.
 3. Cover tape size: 5.40 mm width.
 4. All measurements are in millimeters.

S1480

Figure 13. SKY13321-360LF Tape and Reel Dimensions

Ordering Information

Model Name	Manufacturing Part Number	Evaluation Kit Part Number
SKY13321-360LF SPDT Switch	SKY13321-360LF	SK40709-1, Rev. 3

Copyright © 2009, 2010 Skyworks Solutions, Inc. All Rights Reserved.

Information in this document is provided in connection with Skyworks Solutions, Inc. ("Skyworks") products or services. These materials, including the information contained herein, are provided by Skyworks as a service to its customers and may be used for informational purposes only by the customer. Skyworks assumes no responsibility for errors or omissions in these materials or the information contained herein. Skyworks may change its documentation, products, services, specifications or product descriptions at any time, without notice. Skyworks makes no commitment to update the materials or information and shall have no responsibility whatsoever for conflicts, incompatibilities, or other difficulties arising from any future changes.

No license, whether express, implied, by estoppel or otherwise, is granted to any intellectual property rights by this document. Skyworks assumes no liability for any materials, products or information provided hereunder, including the sale, distribution, reproduction or use of Skyworks products, information or materials, except as may be provided in Skyworks Terms and Conditions of Sale.

THE MATERIALS, PRODUCTS AND INFORMATION ARE PROVIDED "AS IS" WITHOUT WARRANTY OF ANY KIND, WHETHER EXPRESS, IMPLIED, STATUTORY, OR OTHERWISE, INCLUDING FITNESS FOR A PARTICULAR PURPOSE OR USE, MERCHANTABILITY, PERFORMANCE, QUALITY OR NON-INFRINGEMENT OF ANY INTELLECTUAL PROPERTY RIGHT; ALL SUCH WARRANTIES ARE HEREBY EXPRESSLY DISCLAIMED. SKYWORKS DOES NOT WARRANT THE ACCURACY OR COMPLETENESS OF THE INFORMATION, TEXT, GRAPHICS OR OTHER ITEMS CONTAINED WITHIN THESE MATERIALS. SKYWORKS SHALL NOT BE LIABLE FOR ANY DAMAGES, INCLUDING BUT NOT LIMITED TO ANY SPECIAL, INDIRECT, INCIDENTAL, STATUTORY, OR CONSEQUENTIAL DAMAGES, INCLUDING WITHOUT LIMITATION, LOST REVENUES OR LOST PROFITS THAT MAY RESULT FROM THE USE OF THE MATERIALS OR INFORMATION, WHETHER OR NOT THE RECIPIENT OF MATERIALS HAS BEEN ADVISED OF THE POSSIBILITY OF SUCH DAMAGE.

Skyworks products are not intended for use in medical, lifesaving or life-sustaining applications, or other equipment in which the failure of the Skyworks products could lead to personal injury, death, physical or environmental damage. Skyworks customers using or selling Skyworks products for use in such applications do so at their own risk and agree to fully indemnify Skyworks for any damages resulting from such improper use or sale.

Customers are responsible for their products and applications using Skyworks products, which may deviate from published specifications as a result of design defects, errors, or operation of products outside of published parameters or design specifications. Customers should include design and operating safeguards to minimize these and other risks. Skyworks assumes no liability for applications assistance, customer product design, or damage to any equipment resulting from the use of Skyworks products outside of stated published specifications or parameters.

Skyworks, the Skyworks symbol, and "Breakthrough Simplicity" are trademarks or registered trademarks of Skyworks Solutions, Inc., in the United States and other countries. Third-party brands and names are for identification purposes only, and are the property of their respective owners. Additional information, including relevant terms and conditions, posted at www.skyworksinc.com, are incorporated by reference.

X-ON Electronics

Largest Supplier of Electrical and Electronic Components

Click to view similar products for [RF Switch ICs](#) category:

Click to view products by [Skyworks](#) manufacturer:

Other Similar products are found below :

[MASW-008853-TR3000](#) [BGS13SN8E6327XTSA1](#) [BGSX210MA18E6327XTSA1](#) [SKY13446-374LF](#) [SW-227-PIN](#) [CG2185X2](#) [CG2415M6](#)
[MA4SW410B-1](#) [MASW-002102-13580G](#) [MASW-008543-001SMB](#) [MASW-008955-TR3000](#) [TGS4307](#) [BGS 12PL6 E6327](#)
[BGS1414MN20E6327XTSA1](#) [BGS1515MN20E6327XTSA1](#) [BGSA11GN10E6327XTSA1](#) [BGSX28MA18E6327XTSA1](#) [HMC199AMS8](#)
[SKY13374-397LF](#) [SKY13453-385LF](#) [CG2415M6-C2](#) [HMC986A-SX](#) [SW-314-PIN](#) [UPG2162T5N-E2-A](#) [SKY13416-485LF](#)
[MASWSS0204TR-3000](#) [MASWSS0201TR](#) [MASWSS0181TR-3000](#) [MASW-007588-TR3000](#) [MASW-004103-13655P](#) [MASW-003102-](#)
[13590G](#) [MASWSS0202TR-3000](#) [MA4SW310B-1](#) [MA4SW110](#) [SW-313-PIN](#) [CG2430X1](#) [SKY13321-360LF](#) [SKY13405-490LF](#)
[SKYA21001](#) [BGSF 18DM20 E6327](#) [SKY13415-485LF](#) [MMS008PP3](#) [BGS13PN10E6327XTSA1](#) [SKY13319-374LF](#)
[BGS14PN10E6327XTSA1](#) [SKY12213-478LF](#) [SKY13404-466LF](#) [MASW-011060-TR0500](#) [SKYA21024](#) [SKY85601-11](#)