

DATA SHEET

SKY65344-21: 2.4 GHz Transmit/Receive Front-End Module with Integrated Low-Noise Amplifier

Applications

- 2.4 GHz ISM band radios
- ZigBee® FEMs
- IEEE 802.15.4 applications

Features

- Transmit output power > +20 dBm
- Receive path NF < 2.2 dB
- High efficiency PA
- Programmable transmit power levels
- Configurable transmit/bidirectional paths
- Internal switching and control circuits
- Internal RF match and bias circuits
- Single DC supply = 3.3 V
- Interfaces seamlessly with Ember EM250, EM260, and EM35x ZigBee transceivers
- All RF ports are internally DC blocked
- Small footprint, MCM (20-pin, 6 x 6 mm) SMT package (MSL3, 260 °C per JEDEC J-STD-020)



Skyworks Green™ products are compliant with all applicable legislation and are halogen-free. For additional information, refer to *Skyworks Definition of Green™*, document number SQ04-0074.

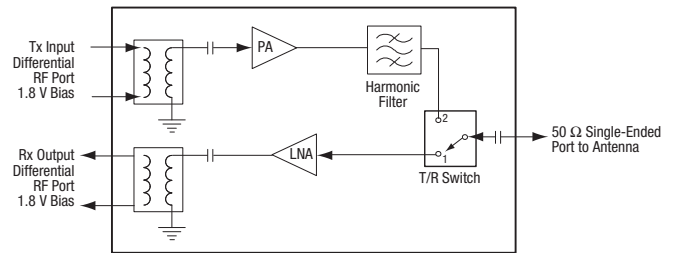

Figure 1. SKY65344-21 Block Diagram

Description

The Skyworks SKY65344-21 is a high-efficiency front-end module (FEM) for ZigBee and other 2.4 GHz ISM band applications. The small, 6 x 6 mm Multi-Chip Module (MCM) contains a 2400 to 2500 MHz high-efficiency transmit path and a low-loss bidirectional path. The bidirectional path can be used to directly connect the antenna port to a directional RF port.

The transmit path consists of an harmonic filter and high efficiency power amplifier (PA) capable of providing +20 dBm of power at the antenna port. Also included is an internal balun to allow use of differential input signals.

The receive path contains a high isolation transmit/receive (T/R) switch, low-noise amplifier (LNA), and balun for low-noise differential output.

The device is mounted in a 20-pin, 6 x 6 mm MCM surface-mount technology (SMT) package, which allows for a highly manufacturable low-cost solution.

A block diagram of the SKY65344-21 is shown in Figure 1. The device package and pinout for the 20-pin MCM are shown in Figure 2. Signal pin assignments and functional pin descriptions are described in Table 1.

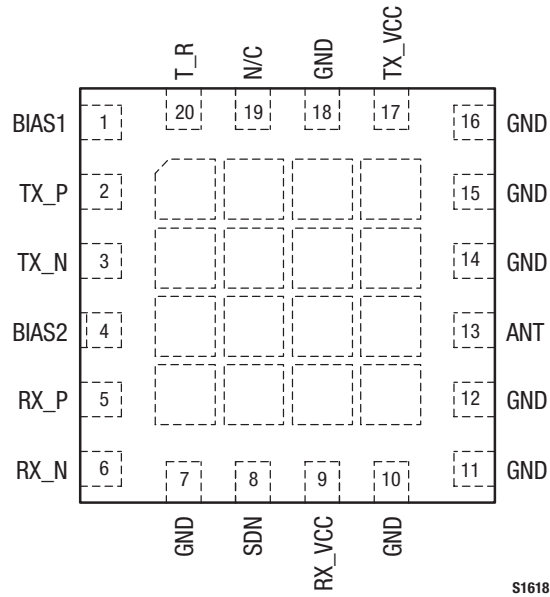

Figure 2. SKY65344-21 Pinout (Top View)

Table 1. SKY65344-21 Signal Descriptions¹

Pin	Name	Description	Pin	Name	Description
1	BIAS1	Transmit port bypass voltage	11	GND	Ground
2	TX_P	Positive transmit input port	12	GND	Ground
3	TX_N	Negative transmit input port	13	ANT	Antenna port
4	BIAS2	Receive port bypass voltage	14	GND	Ground
5	RX_P	Positive receive output port	15	GND	Ground
6	RX_N	Negative receive output port	16	GND	Ground
7	GND	Ground	17	TX_VCC	Transmit DC supply, +3.3 V
8	SDN	Shut down enable	18	GND	Ground
9	RX_VCC	Receive DC supply, +3.3 V	19	N/C	No connection
10	GND	Ground	20	T_R	Transmit/receive control

¹ The bottom ground pad **must be** connected to RF ground.

Technical Description

Shut Down and T/R Switch Mode Control

Pin 8 (SDN) is used to enable the device while pin 20 (T_R) enables transmit or receive mode. The following control logic is used to configure the transmit, receive, or shut down mode of the SKY65344-21:

SDN (Pin 8)	T_R (Pin 20)	Mode
High	High	Transmit mode
High	Low	Receive mode
Low	Low	Shut Down mode

Bottom Center Paddle

The bottom center paddles must be electrically grounded for proper RF performance. Customers should place adequate thermal vias under the ground paddles for optimum thermal performance. The Evaluation Board layout can be used as a guide for RF ground and thermal layout.

Electrical and Mechanical Specifications

The absolute maximum ratings of the SKY65344-21 are provided in Table 2. The recommended operating conditions are specified in Table 3 and electrical specifications are provided in Table 4.

Typical performance characteristics of the SKY65344-21 are shown in Figures 3, 4, and 5.

Table 2. SKY65344-21 Absolute Maximum Ratings¹

Parameter	Symbol	Minimum	Maximum	Units
Supply voltage	RX_VCC, TX_VCC	1.8	4	V
Control voltage	SDN, T_R		3.6	V
Bypass voltage	BIAS1, BIAS2		4	V
RF input power, antenna port	P _{IN_ANT}		+10	dBm
RF input power, transmit port	P _{IN_TX}		+8	dBm
Case operating temperature	T _C	-40	+85	°C
Storage temperature	T _{ST}	-55	+125	°C
Junction temperature	T _J		+150	°C

¹ Exposure to maximum rating conditions for extended periods may reduce device reliability. There is no damage to device with only one parameter set at the limit and all other parameters set at or below their nominal value. Exceeding any of the limits listed here may result in permanent damage to the device.

ESD HANDLING: *Although this device is designed to be as robust as possible, electrostatic discharge (ESD) can damage this device. This device must be protected at all times from ESD when handling or transporting. Static charges may easily produce potentials of several kilovolts on the human body or equipment, which can discharge without detection. Industry-standard ESD handling precautions should be used at all times.*

Table 3. SKY65344-21 Recommended Operating Conditions

Parameter	Symbol	Min	Typ	Max	Units
Frequency range	f	2400		2500	MHz
Supply voltage (TX_VCC, RX_VCC)	VCC	2.7	3.3	3.6	V
Shut down and T/R control voltage:					
Low	T_RL, SDN _L		0	0.1	V
High	T_RH, SDN _H	1.62	1.80	3.60	V

Table 4. SKY65344-21 Electrical Specifications¹
(V_{CC} = 3.3 V, T_c = 25 °C, P_{IN} = +3 dBm, Unless Otherwise Noted)

Parameter	Symbol	Test Condition	Min	Typ	Max	Units
Frequency range	f		2400		2500	MHz
Return loss ²	RL	All RF ports		10		dB
Transmit differential port (TX_P, TX_N) impedance ²	Z _{DTX}			29 + j75		Ω
Receive differential port (RX_P, RX_N) impedance ²	Z _{DRX}			68 + j38		Ω
Transmitter Section						
Input power range	P _{IN}			+3		dBm
Maximum output power ²	P _{SAT}			+21.5		dBm
Transmit output power	P _{OUT}		+19.5	+20.0		dBm
Operating current	I _{OP_H}			105	130	mA
2 nd harmonic	P _{n2}	IEEE 802.15.4 OQPSK modulated		-48	-43	dBm
3 rd harmonic	P _{n3}	IEEE 802.15.4 OQPSK modulated		-49	-43	dBm
Small signal gain ²	G _H	P _{IN} = -10 dBm		20		dB
Spur ²		VSWR up to 10:1 (all phase angles)	No parasitic oscillation > -44 dBm			-
Ruggedness ²		VSWR up to 10:1 (all phase angles)	No module damage or permanent degradation			-
Receive Section						
Small signal gain	G	CW	7	10		dB
Noise figure	NF			2.2	3.0	dB
1 dB input compression point ²	IP1dB	CW		-11		dBm
Third order input intercept point ²	IIP3	Two CW tones, spaced 1 MHz apart @ P _{IN} = -9 dBm		-1		dBm
Operating current	I _{CC}	CW		7	10	mA
Leakage current	I _{LEAK}	No RF input, V _{CC} = 3.3 V, SDN = 0 V, T _R = 0 V		4	10	μA

¹ Performance is guaranteed only under the conditions listed in this table.

² Parameter is characterized under the conditions in this Table but is not production tested.

Typical Performance Characteristics
 (V_{CC} = 3.3 V, T_c = 25 °C, P_{IN} = +3 dBm, Unless Otherwise Noted)

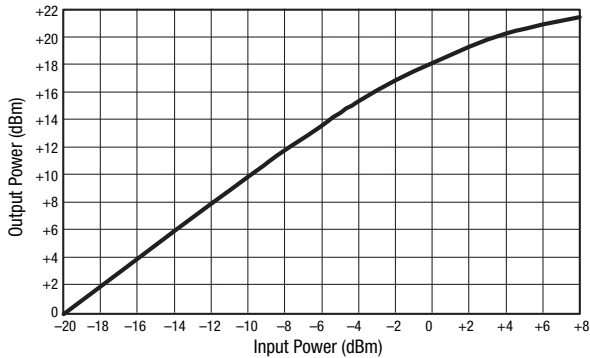

Figure 3. Output Power vs Input Power @ 2445 MHz

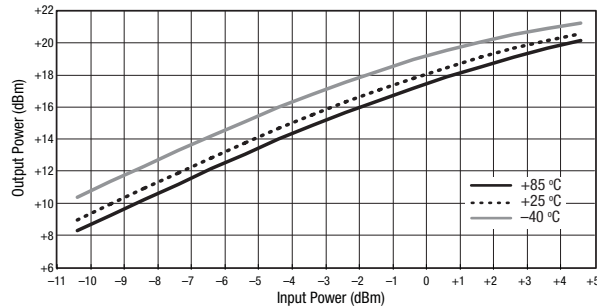

Figure 4. Output Power vs Input Power Over Temperature @ 2445 MHz

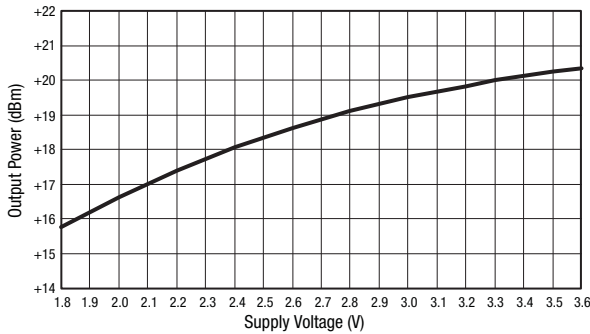
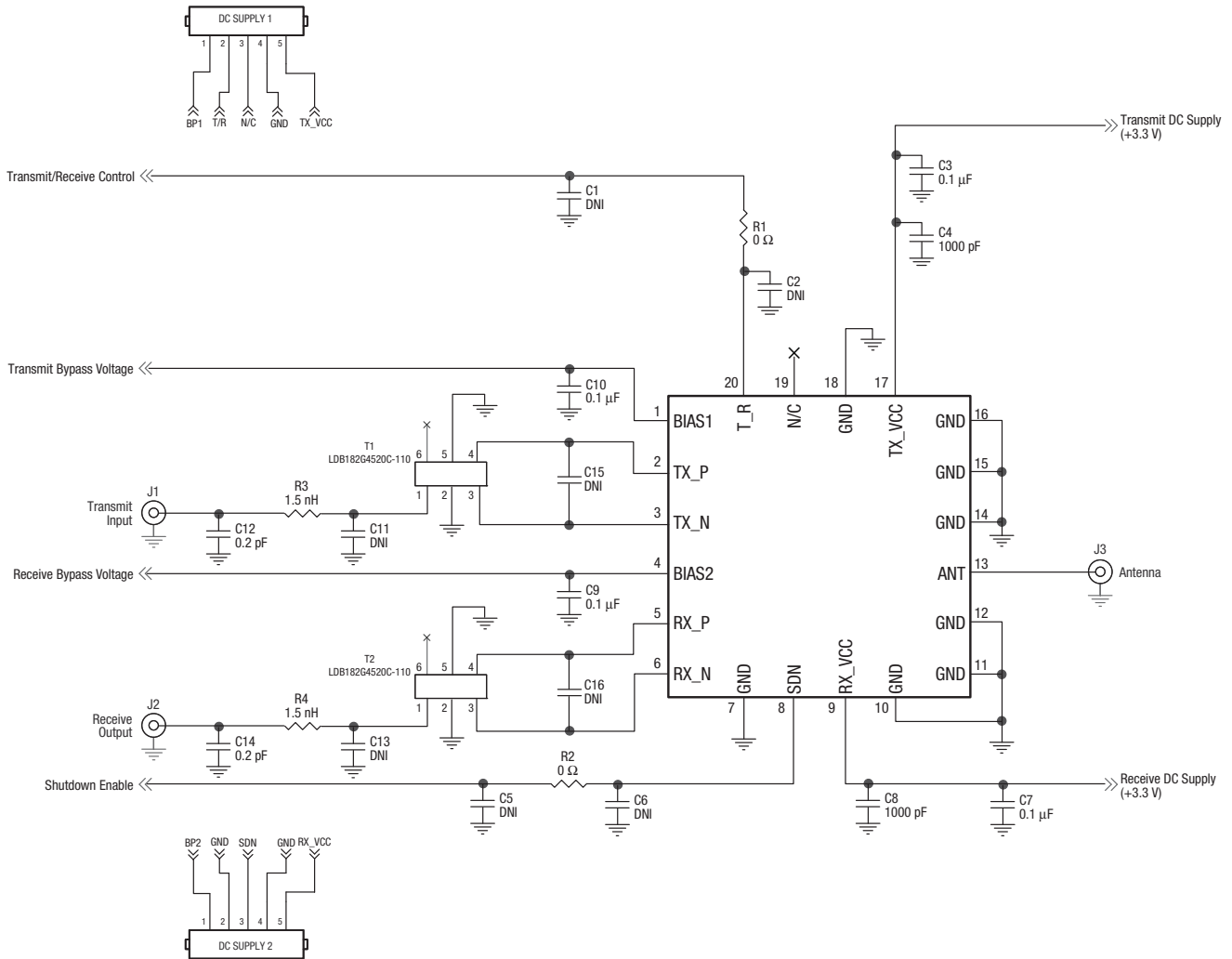

Figure 5. Output Power vs Supply Voltage @ 2445 MHz

Evaluation Board Description

The SKY65344-21 standalone Evaluation Board is used to test the performance of the SKY65344-21 FEM. The Evaluation Board schematic diagram is shown in Figure 6. An assembly drawing for the Evaluation Board is shown in Figure 7.

A reference design Evaluation Board is also available to test the SKY65344-21 with an Ember EM35x series transceiver (see **Ordering Information** on the last page of this data sheet).



Note: Some component labels may be different than the corresponding component symbol shown here. Component values, however, are accurate as of the date of this Data Sheet.

S1775

Figure 6. SKY65344-21 Standalone Evaluation Board Schematic

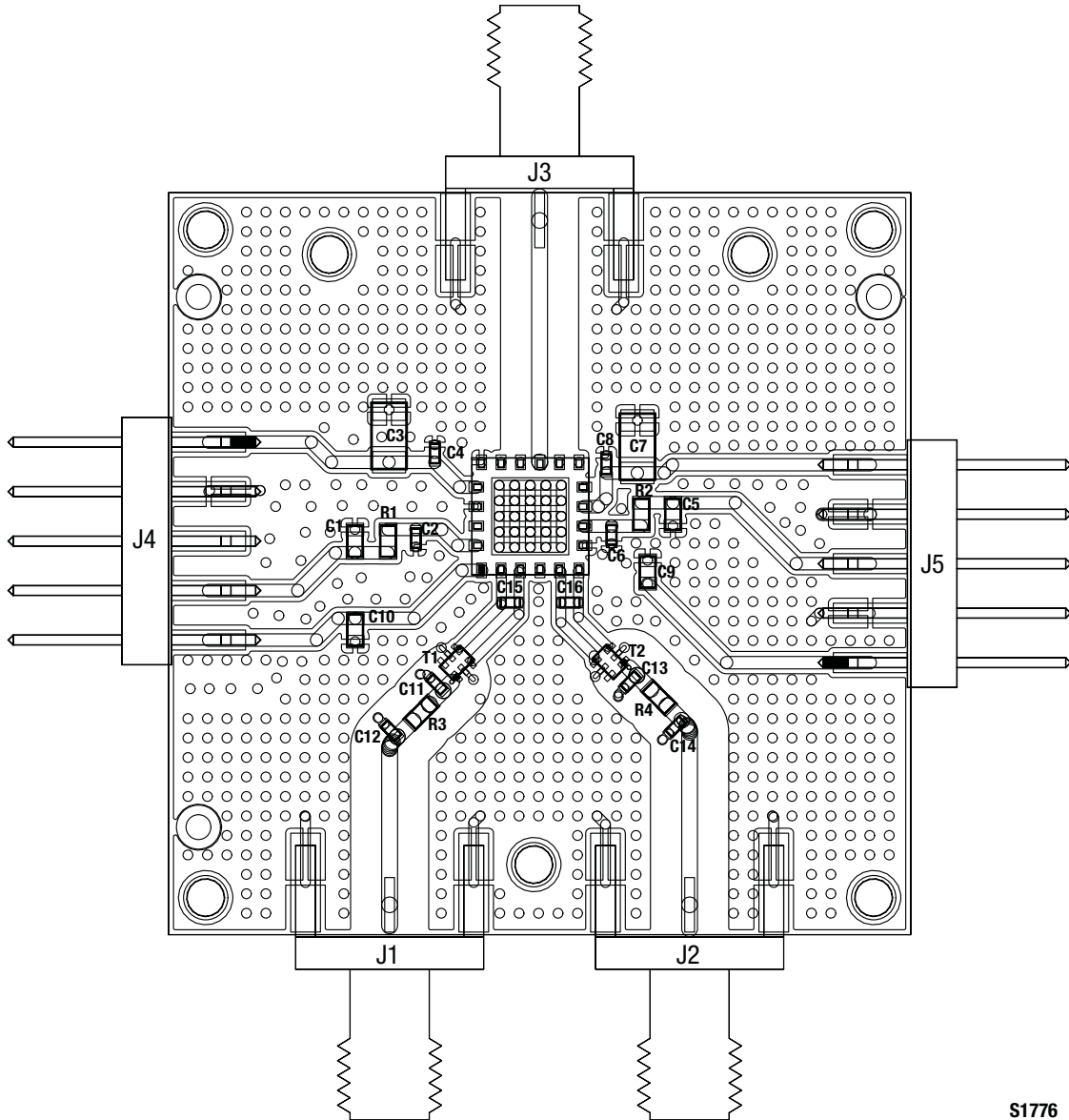

S1776

Figure 7. SKY65344-21 Standalone Evaluation Board Assembly Drawing

Package Dimensions

The phone board layout footprint for the SKY65344-21 is shown in Figure 8. Package dimensions are shown in Figure 9, and tape and reel dimensions are provided in Figure 10.

Package and Handling Information

Since the device package is sensitive to moisture absorption, it is baked and vacuum packed before shipping. Instructions on the shipping container label regarding exposure to moisture after the container seal is broken must be followed. Otherwise, problems related to moisture absorption may occur when the part is subjected to high temperature during solder assembly.

The SKY65344-21 is rated to Moisture Sensitivity Level 3 (MSL3) at 260 °C. It can be used for lead or lead-free soldering. For additional information, refer to Skyworks Application Note, *PCB Design and SMT Assembly/Rework Guidelines for MCM-L Packages*, document number 101752.

Care must be taken when attaching this product, whether it is done manually or in a production solder reflow environment. Production quantities of this product are shipped in a standard tape and reel format.

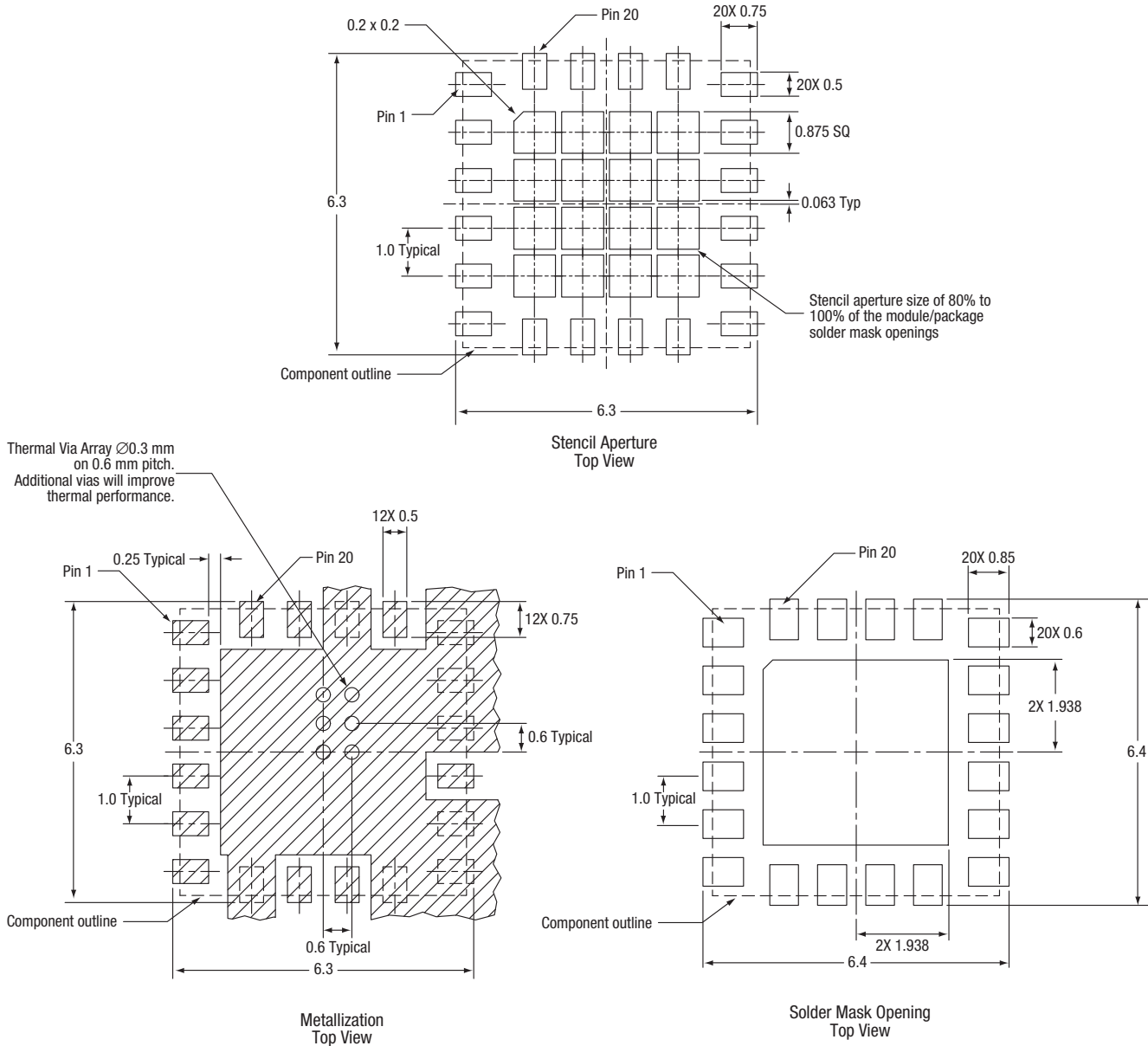

S1789

Figure 8. SKY65344-21 Phone Board Layout Footprint

DATA SHEET • SKY65344-21: TRANSMIT/RECEIVE FRONT-END MODULE WITH LNA

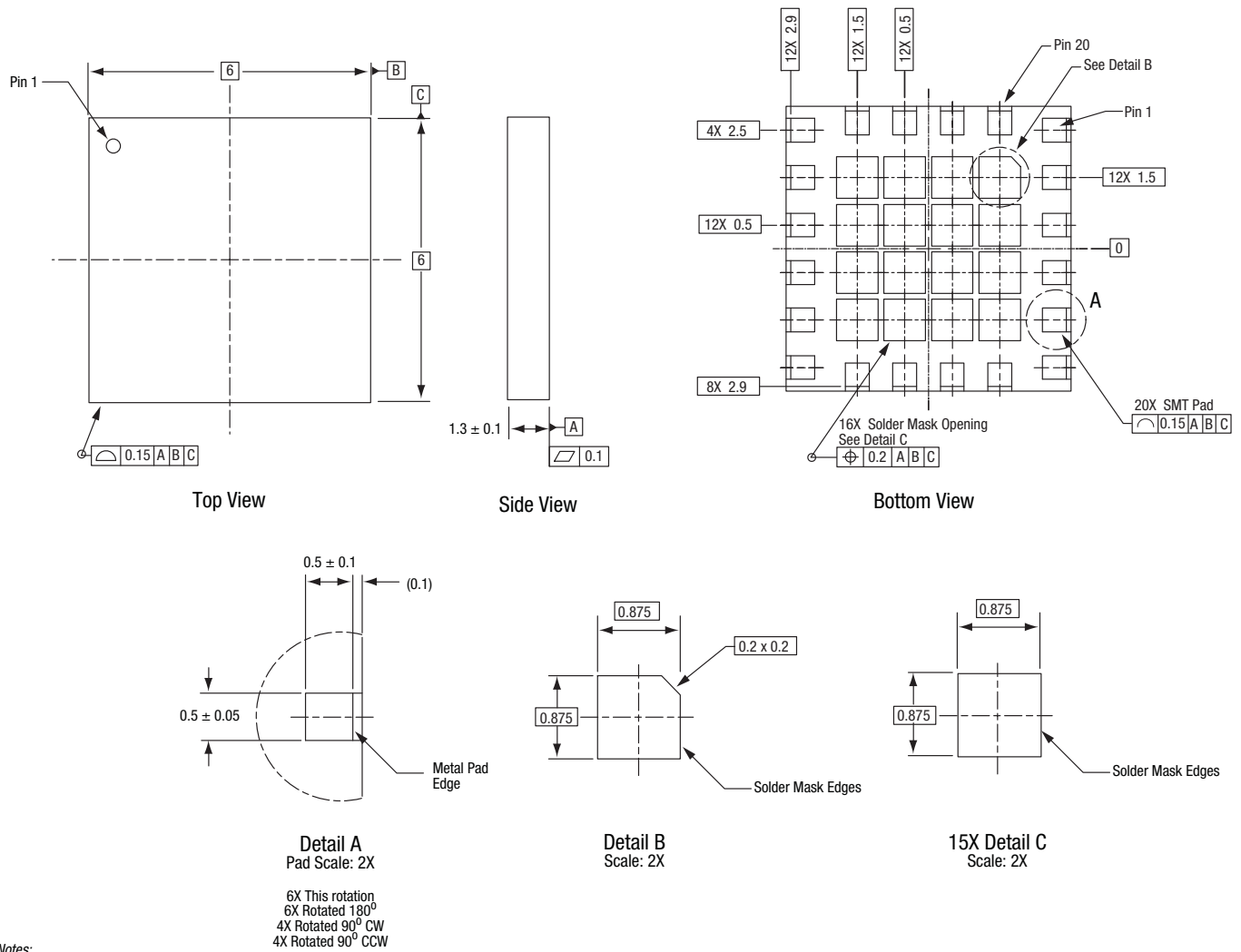

Notes:

1. All dimensions are in millimeters.
2. Dimensioning and tolerancing according to ASME Y14.5M-1994

S1790a

Figure 9. SKY65344-21 Package Dimensions

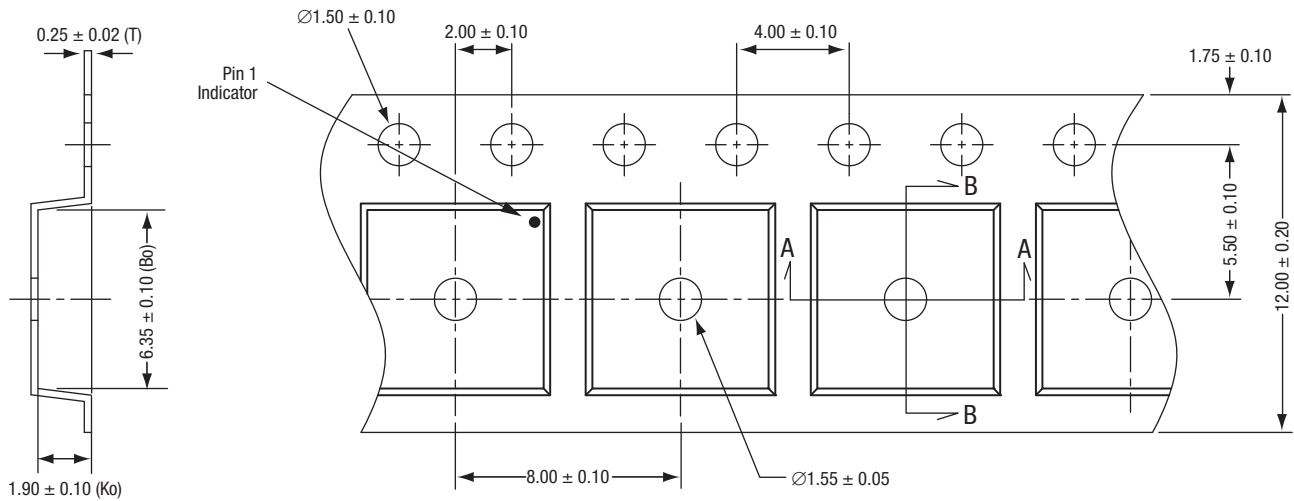

Detail B

Notes:

1. Carrier tape: black conductive polystyrene
2. Cover tape material: transparent conductive PSA
3. Cover tape size: 9.3 mm width
4. ESD surface resistivity is $\leq 1 \times 10^{10}$ Ohms/square per EIA, JEDEC tape and reel specification.
5. Po/P1 10 pitches cumulative tolerance on tape: ± 0.20 mm
6. Ao and Bo measurement point is 0.3 mm from bottom pocket
7. All dimensions are in millimeters

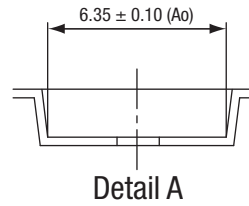

Detail A

S1786

Figure 10. SKY65344-21 Tape and Reel Dimensions

Ordering Information

Model Name	Manufacturing Part Number	Evaluation Board Part Number
SKY65344-21: T/R Front-End Module with LNA	SKY65344-21	SKY65344-21-EVB (standalone board) EM35X_SKY65344 (EM357 and SKY65344-21 Zigbee Reference Design)

Copyright © 2009-2011, 2017 Skyworks Solutions, Inc. All Rights Reserved.

Information in this document is provided in connection with Skyworks Solutions, Inc. (“Skyworks”) products or services. These materials, including the information contained herein, are provided by Skyworks as a service to its customers and may be used for informational purposes only by the customer. Skyworks assumes no responsibility for errors or omissions in these materials or the information contained herein. Skyworks may change its documentation, products, services, specifications or product descriptions at any time, without notice. Skyworks makes no commitment to update the materials or information and shall have no responsibility whatsoever for conflicts, incompatibilities, or other difficulties arising from any future changes.

No license, whether express, implied, by estoppel or otherwise, is granted to any intellectual property rights by this document. Skyworks assumes no liability for any materials, products or information provided hereunder, including the sale, distribution, reproduction or use of Skyworks products, information or materials, except as may be provided in Skyworks Terms and Conditions of Sale.

THE MATERIALS, PRODUCTS AND INFORMATION ARE PROVIDED “AS IS” WITHOUT WARRANTY OF ANY KIND, WHETHER EXPRESS, IMPLIED, STATUTORY, OR OTHERWISE, INCLUDING FITNESS FOR A PARTICULAR PURPOSE OR USE, MERCHANTABILITY, PERFORMANCE, QUALITY OR NON-INFRINGEMENT OF ANY INTELLECTUAL PROPERTY RIGHT; ALL SUCH WARRANTIES ARE HEREBY EXPRESSLY DISCLAIMED. SKYWORKS DOES NOT WARRANT THE ACCURACY OR COMPLETENESS OF THE INFORMATION, TEXT, GRAPHICS OR OTHER ITEMS CONTAINED WITHIN THESE MATERIALS. SKYWORKS SHALL NOT BE LIABLE FOR ANY DAMAGES, INCLUDING BUT NOT LIMITED TO ANY SPECIAL, INDIRECT, INCIDENTAL, STATUTORY, OR CONSEQUENTIAL DAMAGES, INCLUDING WITHOUT LIMITATION, LOST REVENUES OR LOST PROFITS THAT MAY RESULT FROM THE USE OF THE MATERIALS OR INFORMATION, WHETHER OR NOT THE RECIPIENT OF MATERIALS HAS BEEN ADVISED OF THE POSSIBILITY OF SUCH DAMAGE.

Skyworks products are not intended for use in medical, lifesaving or life-sustaining applications, or other equipment in which the failure of the Skyworks products could lead to personal injury, death, physical or environmental damage. Skyworks customers using or selling Skyworks products for use in such applications do so at their own risk and agree to fully indemnify Skyworks for any damages resulting from such improper use or sale.

Customers are responsible for their products and applications using Skyworks products, which may deviate from published specifications as a result of design defects, errors, or operation of products outside of published parameters or design specifications. Customers should include design and operating safeguards to minimize these and other risks. Skyworks assumes no liability for applications assistance, customer product design, or damage to any equipment resulting from the use of Skyworks products outside of stated published specifications or parameters.

Skyworks and the Skyworks symbol are trademarks or registered trademarks of Skyworks Solutions, Inc., in the United States and other countries. Third-party brands and names are for identification purposes only, and are the property of their respective owners. Additional information, including relevant terms and conditions, posted at www.skyworksinc.com, are incorporated by reference.

X-ON Electronics

Largest Supplier of Electrical and Electronic Components

Click to view similar products for [RF Front End](#) category:

Click to view products by [Skyworks](#) manufacturer:

Other Similar products are found below :

[SE2622L-R](#) [BGM1032N7E6327XUSA1](#) [LX5586LL](#) [SKY85703-11](#) [LX5586HLL](#) [LX5586ALL](#) [SKY66111-21](#) [SKY65728-11](#) [SKY68000-31](#)
[SKY85308-11](#) [SKY85302-11](#) [SKY65724-11](#) [ADTR1107ACCZ](#) [LMP91051MTX/NOPB](#) [SE5501L-R](#) [QPF4519SR](#) [SE5503A-R](#)
[ADA8282WBCPZ](#) [ADRF5545ABCPZN](#) [ADRF5545ABCPZN-R7](#) [AD8283WBCPZ](#) [AD8284WCSVZ](#) [ADRF5547BCPZN](#)
[ADRF5547BCPZN-R7](#) [ADRF5549BCPZN](#) [ADRF5549BCPZN-R7](#) [HV7350K6-G](#) [SE5516A-R](#) [MCP2030-I/SL](#) [MAX2009ETI+](#)
[MAX2078CTK+](#) [MAX2335ETI+](#) [MAX2678GTB/V+T](#) [MD2131K7-G](#) [MD2134K7-G](#) [RFFM6903TR13](#) [HV7351K6-G](#) [MCP2035-I/ST](#)
[SE2614BT-R](#) [SE2438T-R](#) [SST12LF02-QXCE](#) [SST12LF09-Q3CE](#) [RFX2401C](#) [RFX2402E](#) [SKY85201-11](#) [RFFM4591FTR7](#) [RFFM8211TR7](#)
[RFFM4293TR7](#) [RFFM4203TR7](#) [RFFM5765QTR7](#)