

**DATA SHEET**

# SKY65943-11: GNSS Low-Noise Amplifier Front-End Module with Integrated Pre-Filter and Post-Filter

## Applications

- Wearables
- Action cameras
- Drones
- Personal navigation devices
- GNSS radio receivers

## Features

- Small signal gain: 16 dB
- Out-of-band P1dB: +6 dBm
- Out-of-band rejection: +80 dBc, 1627 to 1660 MHz
- Low noise figure: 1.7 dB
- Low current consumption: 2.9 mA @ 1.8 V
- Input/output impedance internally matched to 50 Ω
- Single DC supply: 1.62 to 3.3 V
- Minimum number of external SMT devices required
- Small MCM (10-pin, 2.5 x 2.5 mm) package (MSL3, 260 °C per JEDEC J-STD-020)



Skyworks Green™ products are compliant with all applicable legislation and are halogen-free. For additional information, refer to *Skyworks Definition of Green™*, document number SQ04-0074.

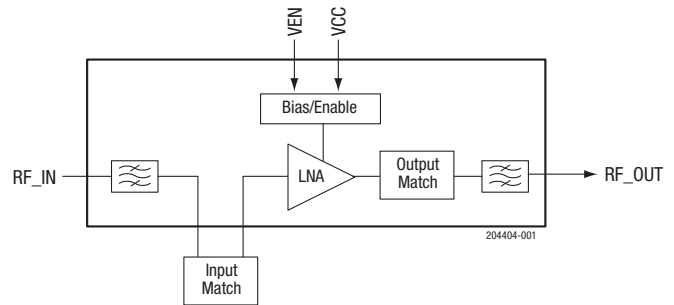

**Figure 1. SKY65943-11 Block Diagram**

## Description

The SKY65943-11 is a front-end module (FEM) with an integrated low-noise amplifier (LNA) and pre-filter and post-filter designed for Global Navigation Satellite System (GNSS) receiver applications. The device provides high gain, excellent out-of-band rejection, and low noise figure. The pre-filter and post-filter provide low in-band insertion loss and excellent rejection for the cellular, PCS, and WLAN frequency bands. Output matching components are embedded inside the device. Only one external input matching inductor is required.

The SKY65943-11 is optimized to operate at 1559 to 1606 MHz, which makes it ideal for GPS/GLONASS/Galileo/Compass/QZSS radio receiver applications.

The SKY65943-11 uses surface-mount technology (SMT) in the form of a 2.5 x 2.5 mm Multi-Chip Module (MCM) package, which allows for a highly manufacturable and low-cost solution.

A functional block diagram is shown in Figure 1. The pin configuration and package are shown in Figure 2. Signal pin assignments and functional pin descriptions are provided in Table 1.

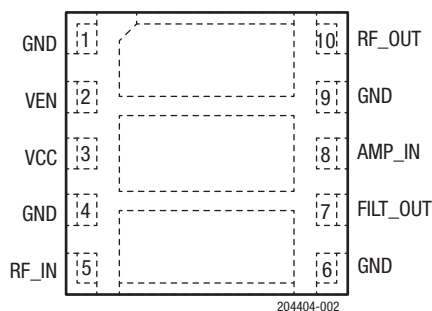

**Figure 2. SKY65943-11 Pinout (Top View)**

**Table 1. SKY65943-11 Signal Descriptions**

Pin	Name	Description	Pin	Name	Description
1	GND	Ground	6	GND	Ground
2	VEN	LNA enable	7	FILT_OUT	Filter output
3	VCC	LNA power supply	8	AMP_IN	LNA input
4	GND	Ground	9	GND	Ground
5	RF_IN	RF input	10	RF_OUT	RF output

## Technical Description

### LNA Enable

The VEN signal (pin 2) enables or disables the LNA. A logic high signal powers on the LNA, and a logic low signal powers off the device.

## Electrical and Mechanical Specifications

The absolute maximum ratings of the SKY65943-11 are provided in Table 2. The recommended operating conditions are specified in Table 3, and electrical specifications are provided in Tables 4 and 5.

**Table 2. SKY65943-11 Absolute Maximum Ratings<sup>1</sup>**

Parameter	Symbol	Minimum	Maximum	Units
RF input power	P <sub>IN</sub>		+10	dBm
Supply voltage	V <sub>CC</sub>	0	3.4	V
Storage temperature	T <sub>STG</sub>	-55	+150	°C
Junction temperature	T <sub>J</sub>		+150	°C
Electrostatic discharge: Human Body Model (HBM), Class 1A	ESD		250	V

<sup>1</sup> Exposure to maximum rating conditions for extended periods may reduce device reliability. There is no damage to device with only one parameter set at the limit and all other parameters set at or below their nominal value. Exceeding any of the limits listed here may result in permanent damage to the device.

**ESD HANDLING:** *Although this device is designed to be as robust as possible, electrostatic discharge (ESD) can damage this device. This device must be protected at all times from ESD when handling or transporting. Static charges may easily produce potentials of several kilovolts on the human body or equipment, which can discharge without detection. Industry-standard ESD handling precautions should be used at all times.*

**Table 3. SKY65943-11 Recommended Operating Conditions**

Parameter	Symbol	Min	Typ	Max	Units
Frequency	f	1559	1575	1606	MHz
Supply voltage	V <sub>CC</sub>	1.62		3.3	V
LNA enable:					
Enable (high)	LNA <sub>ENABLE</sub>	V <sub>CC</sub> - 0.3		V <sub>CC</sub>	V
Disable (low)	LNA <sub>DISABLE</sub>		0	0.3	V
Case temperature	T <sub>C</sub>	-40	+25	+85	°C

**Table 4. SKY65943-11 Electrical Specifications<sup>1</sup>**  
**(V<sub>CC</sub> = 1.8 V, V<sub>EN</sub> = 1.8 V, f = 1575 MHz, T<sub>c</sub> = +25 °C, Unless Otherwise Noted)**

Parameter	Symbol	Test Condition	Min	Typ	Max	Units
Small signal gain	IS21I	P <sub>IN</sub> = -30 dBm:				
		@ 1559 MHz	12	15		dB
		@ 1575 MHz	13.5	15		dB
		@ 1606 MHz	12	15		dB
Noise figure	NF	@ 1559 MHz		2.2	2.6	dB
		@ 1575 MHz		1.7	2.0	dB
		@ 1606 MHz		2.0	2.4	dB
In-band third order input intercept point	IIP3	f <sub>1</sub> = 1575 MHz @ P <sub>IN</sub> = -30 dBm f <sub>2</sub> = 1576 MHz @ P <sub>IN</sub> = -30 dBm		-7		dBm
In-band 1 dB input compression point	IP1dB			-13.5		dBm
Out-of-band 1dB input compression point	OOB_IP1dB	f <sub>OOB</sub> = 1627 MHz, IP1dB@ f=1575 MHz	6			dBm
		f <sub>OOB</sub> = 1540 MHz, IP1dB@ f=1575 MHz	6			dBm
Reverse isolation	IS12I	P <sub>IN</sub> = -30 dBm	30	38		dB
Input return loss	IS11I	P <sub>IN</sub> = -30 dBm		10		dB
Output return loss	IS22I	P <sub>IN</sub> = -30 dBm		13		dB
Supply current	I <sub>CC</sub>	No RF		2.9	4.0	mA
Shutdown current	I <sub>LEAK</sub>	No RF, V <sub>EN</sub> = 0 V		0.1	1	μA
Out-of-band rejection	OOB	P <sub>IN</sub> = 0 dBm (in-band referred):				
		@ 10 to 300 MHz		+80		dBc
		@ 300 to 700 MHz		+90		dBc
		@ 700 to 1525 MHz		+85		dBc
		@ 1525 to 1540 MHz		+60		dBc
		@ 1627 to 1660 MHz		+80		dBc
		@ 1660 to 2500 MHz		+75		dBc
@ 2500 to 6000 MHz		+65		dBc		
LNA turn-on time	t <sub>ON</sub>	P <sub>IN</sub> = -30 dBm, V <sub>CC</sub> = 1.8 V, 50% of Venable to 90% final RF power		1	1.5	μS
LNA turn-off time	t <sub>OFF</sub>	P <sub>IN</sub> = -30 dBm, V <sub>CC</sub> = 1.8 V, 50% of Venable to 10% final RF power		0.1	0.2	μS

<sup>1</sup> Performance is guaranteed only under the conditions listed in this table.

**Table 5. SKY65943-11 Electrical Specifications<sup>1</sup>**  
**(V<sub>CC</sub> = 2.8 V, V<sub>EN</sub> = 2.8 V, f = 1575 MHz, T<sub>c</sub> = +25 °C, Unless Otherwise Noted)**

Parameter	Symbol	Test Condition	Min	Typ	Max	Units
Small signal gain	IS21I	P <sub>IN</sub> = -30 dBm:				
		@ 1559 MHz	13.5	16		dB
		@ 1575 MHz	14.5	16		dB
		@ 1606 MHz	13.0	15.5		dB
Noise figure	NF	@ 1559 MHz		2.2	2.6	dB
		@ 1575 MHz		1.7	2.0	dB
		@ 1606 MHz		2.0	2.4	dB
In-band third order input intercept point	IIP3	f <sub>1</sub> = 1575 MHz @ P <sub>IN</sub> = -30 dBm f <sub>2</sub> = 1576 MHz @ P <sub>IN</sub> = -30 dBm		-7		dBm
In-band 1 dB input compression point	IP1dB			-13.0		dBm
Out-of-band 1dB input compression point	OOB_IP1dB	f <sub>OOB</sub> = 1627 MHz, IP1dB@ f=1575 MHz	6			dBm
		f <sub>OOB</sub> = 1540 MHz, IP1dB@ f=1575 MHz	6			dBm
Reverse isolation	IS12I	P <sub>IN</sub> = -30 dBm		40		dB
Input return loss	IS11I	P <sub>IN</sub> = -30 dBm		12		dB
Output return loss	IS22I	P <sub>IN</sub> = -30 dBm		18		dB
Supply current	ICC	No RF		3	4.5	mA
Shutdown current	ILEAK	No RF, V <sub>EN</sub> = 0 V		0.1	1	µA
Out-of-band rejection	OOB	P <sub>IN</sub> = 0 dBm (in-band referred):				
		@ 10 to 300 MHz		+80		dBc
		@ 300 to 700 MHz		+90		dBc
		@ 700 to 1525 MHz		+85		dBc
		@ 1525 to 1540 MHz		+60		dBc
		@ 1627 to 1660 MHz		+80		dBc
@ 1660 to 2500 MHz		+75		dBc		
@ 2500 to 6000 MHz		+65		dBc		
LNA turn-on time	T <sub>ON</sub>	P <sub>IN</sub> = -30 dBm, V <sub>CC</sub> = 2.8 V, 50% of Venable to 90% final RF power		1	1.5	µS
LNA turn-off time	T <sub>OFF</sub>	P <sub>IN</sub> = -30 dBm, V <sub>CC</sub> = 2.8 V, 50% of Venable to 10% final RF power		0.1	0.2	µS

<sup>1</sup> Performance is guaranteed only under the conditions listed in this table.

## Evaluation Board Description

The SKY65943-11 Evaluation Board is used to test the performance of the SKY65943-11 LNA. An assembly drawing for the Evaluation Board is shown in Figure 3. The Evaluation Board schematic diagram is shown in Figure 4. Table 6 provides the Bill of Materials (BOM) list for Evaluation Board components.

## Package Dimensions

The PCB layout footprint for the SKY65943-11 is provided in Figure 5. Typical part markings are shown in Figure 6. Package dimensions are shown in Figure 7, and tape and reel dimensions are provided in Figure 8.

## Package and Handling Information

Since the device package is sensitive to moisture absorption, it is baked and vacuum packed before shipping. Instructions on the shipping container label regarding exposure to moisture after the container seal is broken must be followed. Otherwise, problems related to moisture absorption may occur when the part is subjected to high temperature during solder assembly.

The SKY65943-11 is rated to Moisture Sensitivity Level 3 (MSL3) at 260 °C. It can be used for lead or lead-free soldering. For additional information, refer to the Skyworks Application Note, *PCB Design & SMT Assembly/Rework Guidelines for MCM-L Packages*, document number 101752.

Care must be taken when attaching this product, whether it is done manually or in a production solder reflow environment. Production quantities of this product are shipped in a standard tape and reel format.

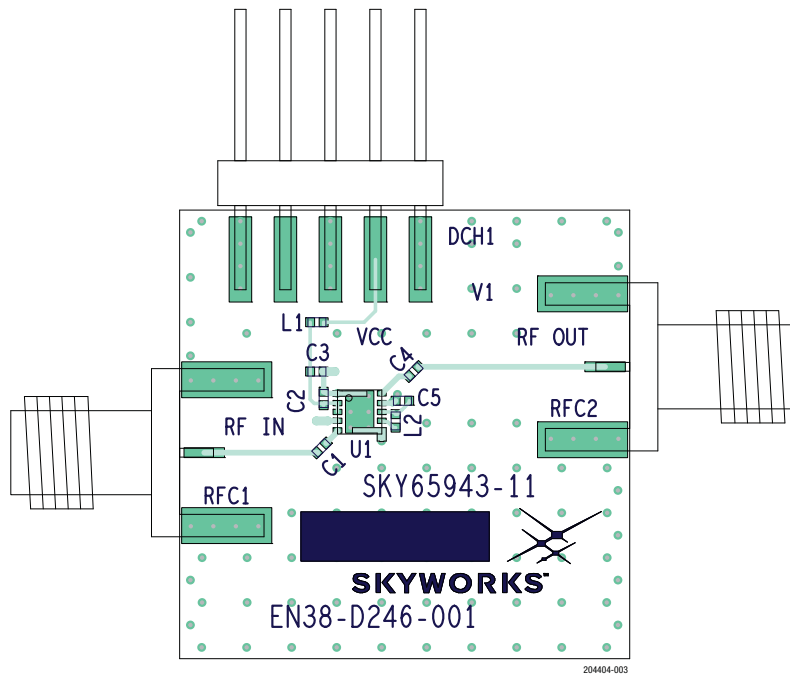

Figure 3. SKY65943-11 Evaluation Board Assembly Diagram

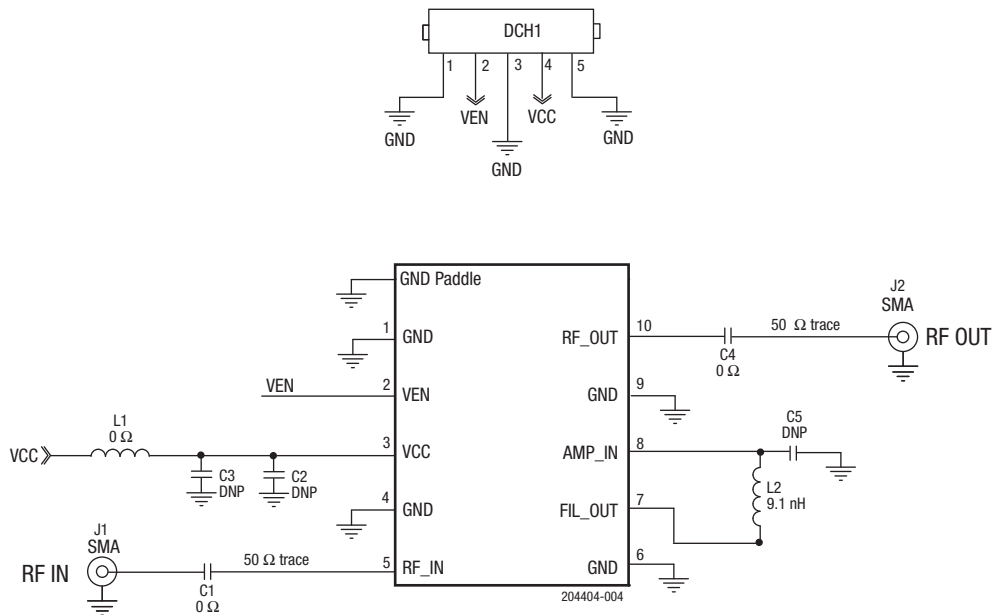
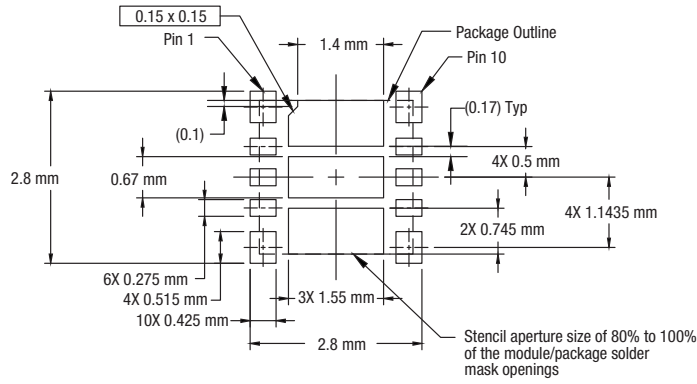

Figure 4. SKY65943-11 Evaluation Board Schematic

Table 6. SKY65943-11 Evaluation Board Bill of Materials

Component	Size	Value	Manufacturer	Mfr Part Number
L1 (optional)	0402	0 Ω	Panasonic	ERJ-2GE0R00X
L2	0402	9.1 nH	Murata	LQW15AN9N1J00D
C1, C4	0402	0 Ω	Panasonic	ERJ-2GE0R00X
C2, C3, C5	0402	DNP		DNP



Stencil Aperture

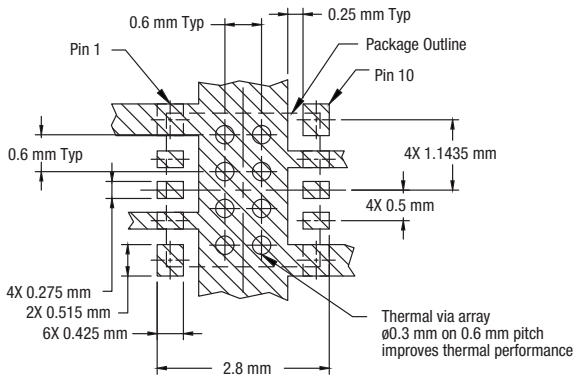

Metallization

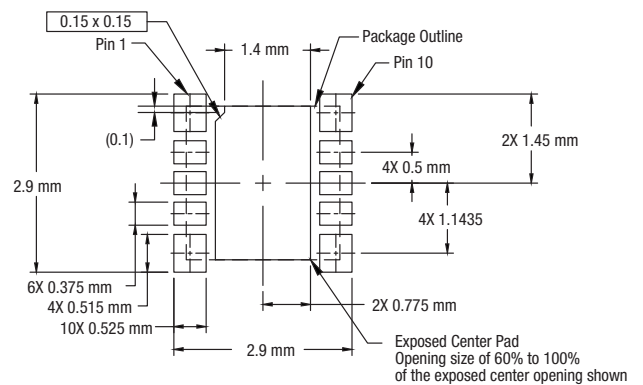

Solder Mask Opening

Notes:

1. All dimensions are in millimeters, unless otherwise specified.
2. Thermal vias should be resin filled and capped in accordance with IPC-4761 Type VII vias. Recommended Cu thickness is 30 to 35  $\mu$ m.

204404-005

Figure 5. SKY65943-11 PCB Layout Footprint

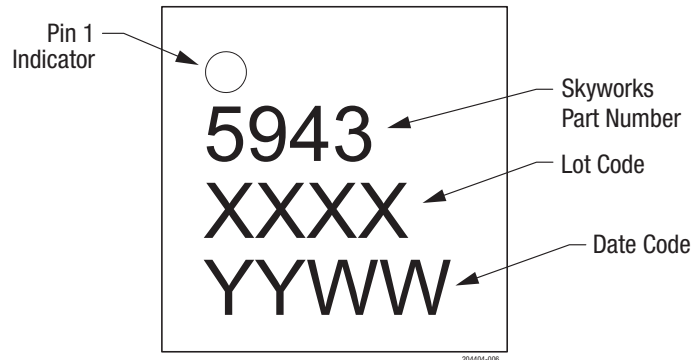
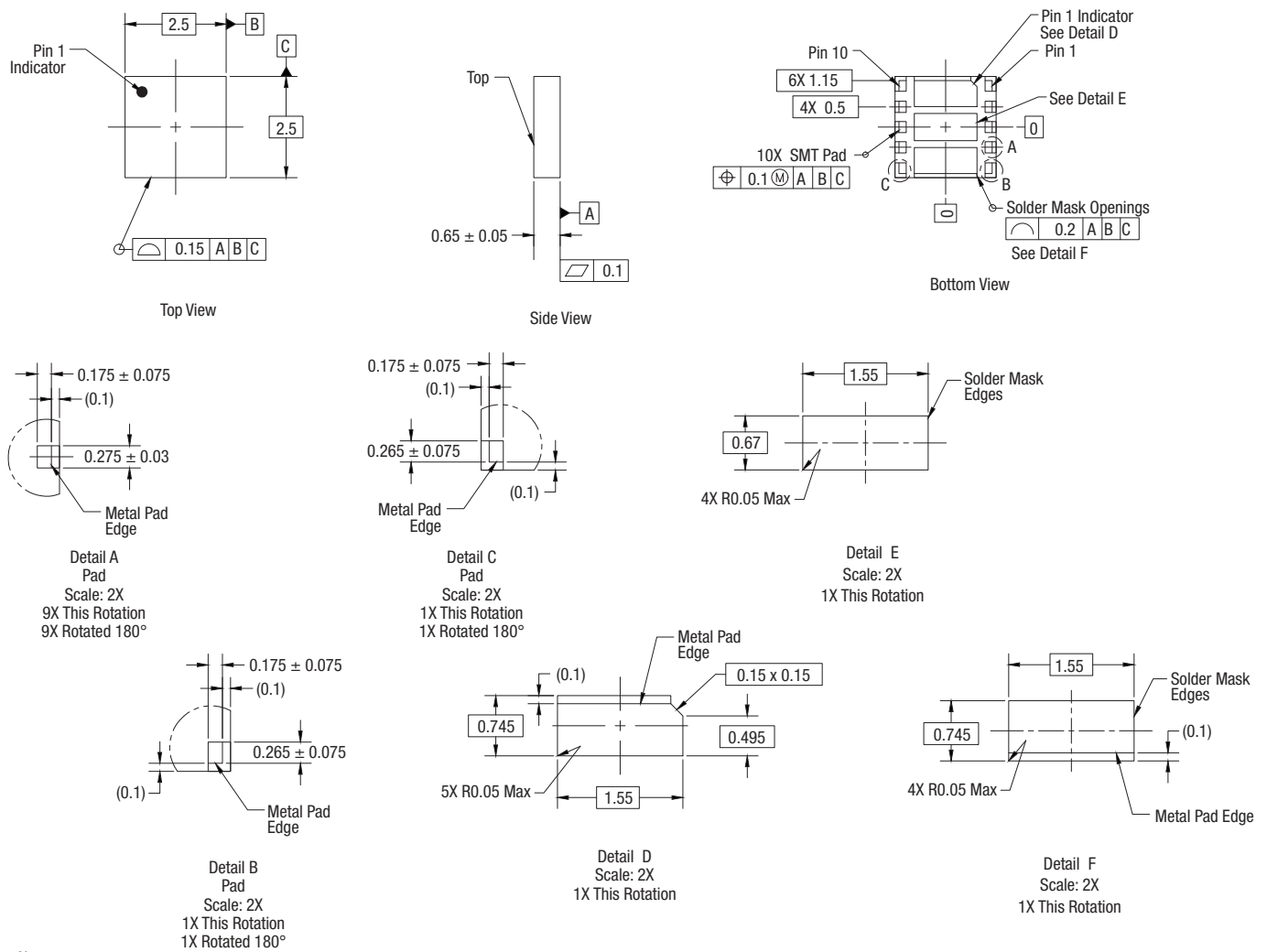

Figure 6. Typical Part Markings (Top View)

**DATA SHEET • SKY65943-11: GNSS LOW-NOISE AMPLIFIER FEM WITH GPS/GLONASS/BDS PRE-FILTER AND POST-FILTER**



**Notes:**

1. Dimensions are in millimeters.
2. Dimensions and tolerances according to ASME Y14.5M-1994.
3. Pad definitions per details on drawing.

**Figure 7. SKY65943-11 Package Dimensions**

204404-007



**DATA SHEET • SKY65943-11: GNSS LOW-NOISE AMPLIFIER FEM WITH GPS/GLONASS/BDS PRE-FILTER AND POST-FILTER**

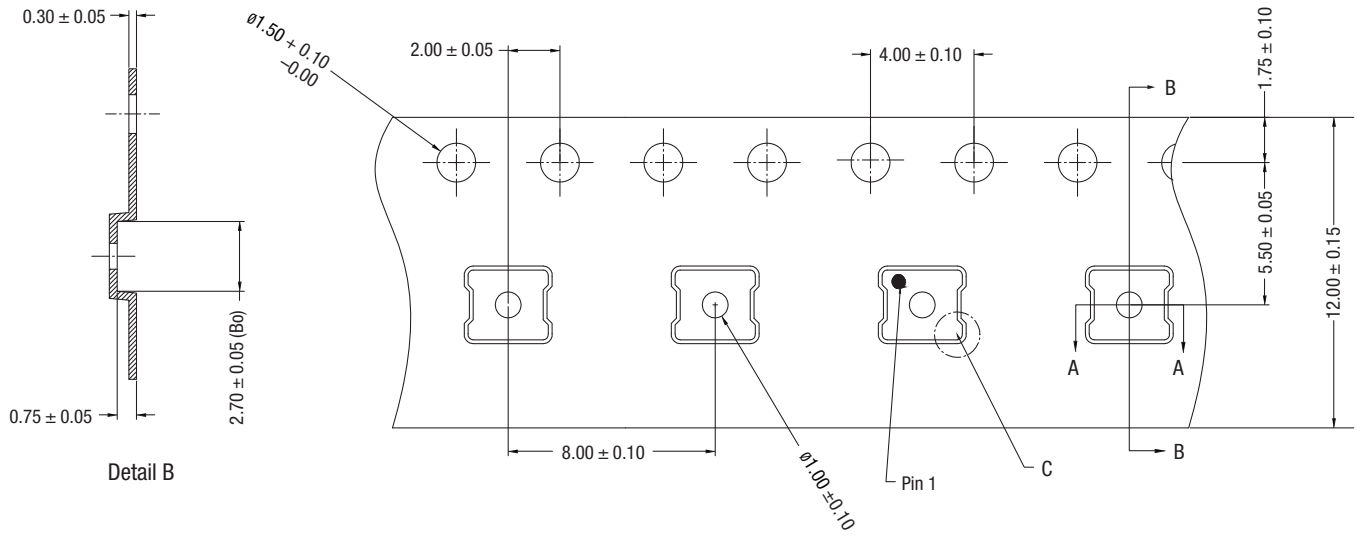

Detail B

**Notes:**

1. Carrier tape must meet all requirements of Skyworks GP01-D233 procurement spec for tape and reel shipping.
2. Carrier tape shall be black conductive polycarbonate or polystyrene.
3. Cover tape shall be transparent conductive material.
4. ESD-surface resistivity shall meet GP01-D233 .
5. 10-sprocket hole pitch cumulative tolerance:  $\pm 0.20$  mm.
6. Ao and Bo measured on plane 0.30 mm above the bottom of the pocket.
7. All measurements are in millimeters.

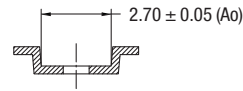

Detail A

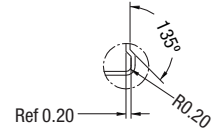

Detail C

204404-008

**Figure 8. SKY65943-11 Tape and Reel Dimensions**

## Ordering Information

Part Number	Product Description	Evaluation Board Part Number
SKY65943-11	GNSS LNA Front-End Module with Pre-Filter and Post-Filter	SKY65943-11-EVB

Copyright © 2016-2018 Skyworks Solutions, Inc. All Rights Reserved.

Information in this document is provided in connection with Skyworks Solutions, Inc. (“Skyworks”) products or services. These materials, including the information contained herein, are provided by Skyworks as a service to its customers and may be used for informational purposes only by the customer. Skyworks assumes no responsibility for errors or omissions in these materials or the information contained herein. Skyworks may change its documentation, products, services, specifications or product descriptions at any time, without notice. Skyworks makes no commitment to update the materials or information and shall have no responsibility whatsoever for conflicts, incompatibilities, or other difficulties arising from any future changes.

No license, whether express, implied, by estoppel or otherwise, is granted to any intellectual property rights by this document. Skyworks assumes no liability for any materials, products or information provided hereunder, including the sale, distribution, reproduction or use of Skyworks products, information or materials, except as may be provided in Skyworks Terms and Conditions of Sale.

THE MATERIALS, PRODUCTS AND INFORMATION ARE PROVIDED “AS IS” WITHOUT WARRANTY OF ANY KIND, WHETHER EXPRESS, IMPLIED, STATUTORY, OR OTHERWISE, INCLUDING FITNESS FOR A PARTICULAR PURPOSE OR USE, MERCHANTABILITY, PERFORMANCE, QUALITY OR NON-INFRINGEMENT OF ANY INTELLECTUAL PROPERTY RIGHT; ALL SUCH WARRANTIES ARE HEREBY EXPRESSLY DISCLAIMED. SKYWORKS DOES NOT WARRANT THE ACCURACY OR COMPLETENESS OF THE INFORMATION, TEXT, GRAPHICS OR OTHER ITEMS CONTAINED WITHIN THESE MATERIALS. SKYWORKS SHALL NOT BE LIABLE FOR ANY DAMAGES, INCLUDING BUT NOT LIMITED TO ANY SPECIAL, INDIRECT, INCIDENTAL, STATUTORY, OR CONSEQUENTIAL DAMAGES, INCLUDING WITHOUT LIMITATION, LOST REVENUES OR LOST PROFITS THAT MAY RESULT FROM THE USE OF THE MATERIALS OR INFORMATION, WHETHER OR NOT THE RECIPIENT OF MATERIALS HAS BEEN ADVISED OF THE POSSIBILITY OF SUCH DAMAGE.

Skyworks products are not intended for use in medical, lifesaving or life-sustaining applications, or other equipment in which the failure of the Skyworks products could lead to personal injury, death, physical or environmental damage. Skyworks customers using or selling Skyworks products for use in such applications do so at their own risk and agree to fully indemnify Skyworks for any damages resulting from such improper use or sale.

Customers are responsible for their products and applications using Skyworks products, which may deviate from published specifications as a result of design defects, errors, or operation of products outside of published parameters or design specifications. Customers should include design and operating safeguards to minimize these and other risks. Skyworks assumes no liability for applications assistance, customer product design, or damage to any equipment resulting from the use of Skyworks products outside of stated published specifications or parameters.

Skyworks and the Skyworks symbol are trademarks or registered trademarks of Skyworks Solutions, Inc. or its subsidiaries in the United States and other countries. Third-party brands and names are for identification purposes only, and are the property of their respective owners. Additional information, including relevant terms and conditions, posted at [www.skyworksinc.com](http://www.skyworksinc.com), are incorporated by reference.

## X-ON Electronics

Largest Supplier of Electrical and Electronic Components

*Click to view similar products for [RF Development Tools](#) category:*

*Click to view products by [Skyworks](#) manufacturer:*

Other Similar products are found below :

[MAAM-011117](#) [MAAP-015036-DIEEV2](#) [EV1HMC1113LP5](#) [EV1HMC6146BLC5A](#) [EV1HMC637ALP5](#) [EVAL-ADG919EBZ](#) [ADL5363-EVALZ](#) [LMV228SDEVAL](#) [SKYA21001-EVB](#) [SMP1331-085-EVB](#) [EV1HMC618ALP3](#) [EVAL01-HMC1041LC4](#) [MAAL-011111-000SMB](#)  
[MAAM-009633-001SMB](#) [107712-HMC369LP3](#) [107780-HMC322ALP4](#) [SP000416870](#) [EV1HMC470ALP3](#) [EV1HMC520ALC4](#)  
[EV1HMC244AG16](#) [MAX2614EVKIT#](#) [124694-HMC742ALP5](#) [SC20ASATEA-8GB-STD](#) [MAX2837EVKIT+](#) [MAX2612EVKIT#](#)  
[MAX2692EVKIT#](#) [EV1HMC629ALP4E](#) [SKY12343-364LF-EVB](#) [108703-HMC452QS16G](#) [EV1HMC863ALC4](#) [EV1HMC427ALP3E](#)  
[119197-HMC658LP2](#) [EV1HMC647ALP6](#) [ADL5725-EVALZ](#) [106815-HMC441LM1](#) [EV1HMC1018ALP4](#) [UXN14M9PE](#) [MAX2016EVKIT](#)  
[EV1HMC939ALP4](#) [MAX2410EVKIT](#) [MAX2204EVKIT+](#) [EV1HMC8073LP3D](#) [SIMSA868-DKL](#) [SIMSA868C-DKL](#) [SKY65806-636EK1](#)  
[SKY68020-11EK1](#) [SKY67159-396EK1](#) [SKY66181-11-EK1](#) [SKY65804-696EK1](#) [SKY13396-397LF-EVB](#)