

DATA SHEET

SKY66118-11: 2.4 GHz +20 dBm Front-End Module for Bluetooth® IoT Applications

Applications

- Wearables
- Personal trackers
- Smart appliances
- Smart thermostats
- Smart lighting
- BT connectivity modules
- Internet of Things (IoT) devices

Features

- Integrated PA with up to +20 dBm output power
- Integrated bypass path, matching and harmonic filtering
- Output power control: ± 1 dB
- Wide supply range: 1.7 V to 3.3 V
- Fast switch on/off time: 800 ns
- Low sleep current: $< 1 \mu\text{A}$
- Wide temperature range: -40°C to 105°C
- Small MCM (18-pin, 2.6 mm x 2.4 mm x 0.75 mm) package, (MSL3, 260 °C per JEDEC-J-STD-020)



Skyworks Green™ products are compliant with all applicable legislation and are halogen-free. For additional information, refer to *Skyworks Definition of Green™*, document number SQ04-0074.

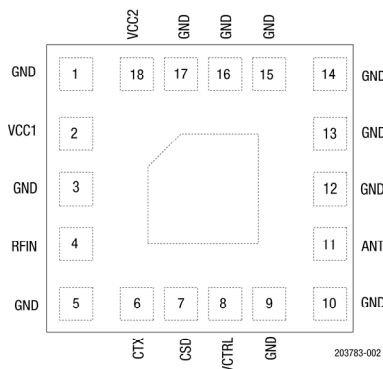

Figure 2. SKY66118-11 Pinout (Top View)

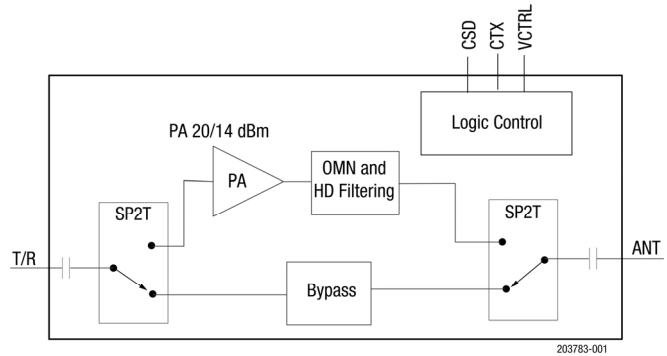

Figure 1. SKY66118-11 Block Diagram

Description

The SKY66118-11 is a high-performance, fully integrated RF front-end module (FEM) designed for Bluetooth, Zigbee®, and Thread applications.

The SKY66118-11 is designed for ease of use and maximum flexibility. The device integrates a +20 dBm power amplifier, RF switches, output matching, and harmonic filtering. Using simple 2-pin GPIO control, the FEM supports three modes of operation (transmit mode, bypass mode, and an ALL OFF sleep mode). The output power can also be externally adjusted through the VCTRL pin.

A low transmit current consumption and operation over a wide supply range enable the FEM to be used with a direct battery connection, supporting a wide range of battery discharge voltages.

A functional block diagram is shown in Figure 1. The SKY66118-11 is provided in a small, 18-pin, 2.6 mm x 2.4 mm Multi-Chip Module (MCM) package. The pin configuration and package are shown in Figure 2. Signal pin assignments and functional pin descriptions are provided in Table 1.

Table 1. SKY66118-11 Signal Descriptions¹

Pin	Name	Description	Pin	Name	Description
1	GND	Ground	10	GND	Ground
2	VCC1	Connect to positive supply	11	ANT	Connect to 50 Ω antenna
3	GND	Ground	12	GND	Ground
4	RFIN	RF input power	13	GND	Ground
5	GND	Ground	14	GND	Ground
6	CTX	Transmit enable control input (see Table 6)	15	GND	Ground
7	CSD	Shutdown control input (see Table 6)	16	GND	Ground
8	VCTRL	Output power control voltage	17	GND	Ground
9	GND	Ground	18	VCC2	Connect to positive supply

¹ The paddle should be connected to ground.

Electrical and Mechanical Specifications

The absolute maximum ratings of the SKY66118-11 are provided in Table 2. The recommended operating conditions are specified in Table 3, and electrical specifications are provided in Tables 4 and 5.

The state of the SKY66118-11 is determined by the logic provided in Table 6.

Table 2. SKY66118-11 Absolute Maximum Ratings¹

Parameter	Symbol	Minimum	Maximum	Units
Supply voltage	V _{CC1}	-0.3	+3.6	V
	V _{CC2}	-0.3	+3.6	V
Control pin voltages (CTX and CSD)	V _{CTRL}	-0.3	+3.6	V
Transmit output power at ANT port into 50 Ω load	P _{OUT_TX_MAX}		+22	dBm
Transmit input power at RFIN port	P _{IN_TX_MAX}		+5.0	dBm
Bypass input power at ANT port ²	P _{IN_BYP_MAX}		+20	dBm
Operating temperature	T _A	-40	+105	°C
Storage temperature	T _{STG}	-40	+125	°C
Electrostatic discharge:	ESD			
Human Body Model (HBM), pin 11 (PAOUT)			500	V
Human Body Model (HBM), all other pins			3000	V

¹ Exposure to maximum rating conditions for extended periods may reduce device reliability. There is no damage to device with only one parameter set at the limit and all other parameters set at or below their nominal value. Exceeding any of the limits listed here may result in permanent damage to the device.

² CW test signal.

ESD HANDLING: *Although this device is designed to be as robust as possible, electrostatic discharge (ESD) can damage this device. This device must be protected at all times from ESD when handling or transporting. Static charges may easily produce potentials of several kilovolts on the human body or equipment, which can discharge without detection. Industry-standard ESD handling precautions should be used at all times.*

Table 3. SKY66118-11 Recommended Operating Conditions

Parameter	Symbol	Min	Typ	Max	Units
Supply voltage on VCC1 pin	Vcc1	1.7	3.0	3.3	V
Supply voltage on VCC2 pin	Vcc2	1.7	3.0	3.3	V
Supply voltage on VCTRL pin	VCTRL	0.6		3.3	V
Operating temperature	TA	-40	+25	+105	°C

Table 4. SKY66118-11 Electrical Specifications¹

(Vcc1 = 3.0 V, Vcc2 = 3.0 V, VCTRL = 3.0 V, TA = +25 °C, Unless Otherwise Noted)

Parameter	Symbol	Test Condition	Min	Typ	Max	Units
DC Characteristics						
Total supply current	I _{CC_TX}	P _{OUT} = +20 dBm P _{OUT} = +14 dBm		90 55		mA mA
Total supply current	I _{CC_BYP}			5		μA
Sleep supply current	I _{CC_OFF}	No RF			1	μA
Quiescent current	I _{CCQ_TX}	No RF		30		mA
Logic Characteristics						
Control voltage (CTX and CSD): High Low	V _{IH} V _{IL}		1.6	1.8 0	VCC1 0.3	V V
Control current (CTX and CSD): High Low	I _{IH} I _{IL}				1.0 1.0	μA μA
VCTRL	VCTRL		0.6		VCC1	V

¹ Performance is guaranteed only under the conditions listed in this table.

Table 5. SKY66118-11 Electrical Specifications¹
(Vcc1 = 3.0 V, Vcc2 = 3.0 V, VCTRL = 3.0 V, TA = +25 °C, All Unused Ports Terminated with 50 Ω, Unless Otherwise Noted)

Parameter	Symbol	Test Condition	Min	Typ	Max	Units
Transmit Characteristics						
Frequency range	f		2400		2483	MHz
Output power at ANT port	POUT ²	BDR, GFSK EDR-3, 8-DPSK		+20 +14		dBm dBm
Saturated gain	GSAT			19		dB
Flatness over band	ΔPOUT			±0.5		dB
Output power control		1.6 V < VCTRL < 3.6 V		±1		dB
2nd and 3rd harmonics	2fo, 3fo ³	POUT = +20 dBm, BDR, GFSK			-42	dBm/MHz
Input return loss	S11			-10		dB
Turn-on time	trISE	From 50% of CTX edge to 90% of final RF power		800		ns
Turn-off time	tFALL	From 50% of CTX edge to 90% of final RF power		800		ns
Stability	STAB	CW, PIN=0 dBm, 0.1 GHz to 20 GHz, load VSWR = 6:1	All non-harmonically related outputs < -42 dBm/MHz			
Ruggedness	RUG	CW, PIN =0 dBm, load VSWR = 10:1	No permanent damage			
Bypass Characteristics						
Frequency range	f		2400		2483	MHz
Bypass gain	BYP_GAIN			-1.7		dB
Input return loss	S11			-10		dB
Output return loss	S22			-12		dB

¹ Performance is guaranteed only under the conditions listed in this table.

² POUT can be controlled by varying the VCTRL. See Figures 3 through 6.

³ Guaranteed by characterization.

Table 6. SKY66118-11 Mode Control Logic

Mode	Description	CSD	CTX
0	ALL OFF (sleep mode)	0	X
1	Transmit mode	1	1
2	Bypass mode	1	0

VCTRL Pin Usage

The SKY66118-11 VCTRL pin supplies the bias to the internal PA. By varying the voltage at this pin, PA operating parameters including gain, supply current, and efficiency can be adjusted.

The VCTRL pin can also be used to adjust the SKY66118-11 output power when the RF source (transceiver or baseband) has a fixed level.

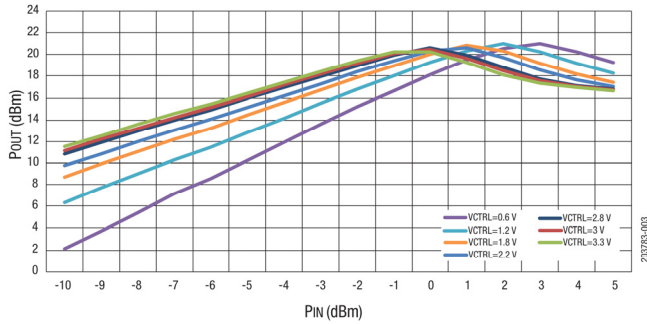

Figure 3. POUT vs PIN vs VCTRL (Vcc1 = Vcc2 = 3 V), f = 2440 MHz, CW

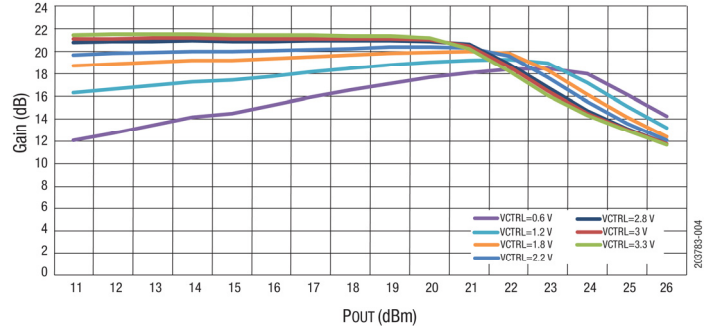

Figure 4. Gain vs POUT vs VCTRL (Vcc1 = Vcc2 = 3 V), f = 2440 MHz, CW

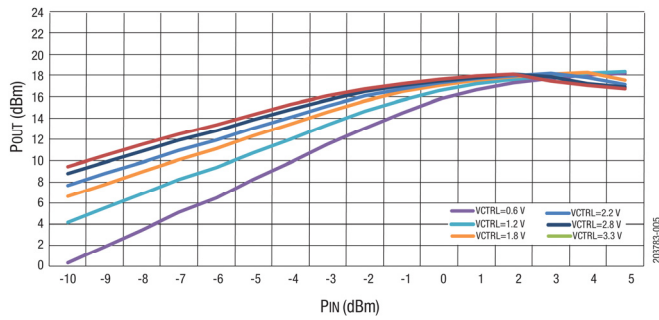

Figure 5. POUT vs PIN vs VCTRL (Vcc1 = Vcc2 = 1.8 V), f = 2440 MHz, CW

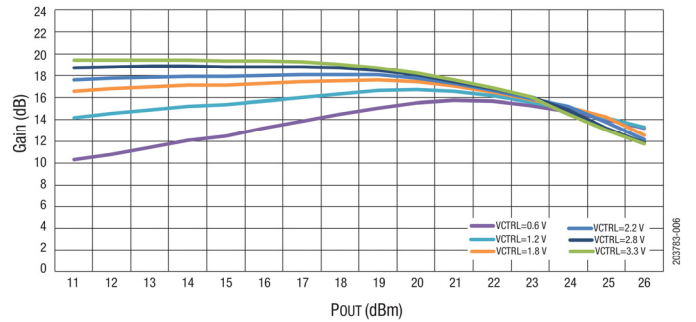

Figure 6. Gain vs POUT vs VCTRL (Vcc1 = Vcc2 = 1.8 V), f = 2440 MHz, CW

Application Schematic Description

A reference design schematic is provided in Figure 7. An evaluation board schematic diagram is shown in Figure 8.

A photograph of the Evaluation Board is shown in Figure 9. The Evaluation Board Bill of Materials (BOM) is shown in Table 7.

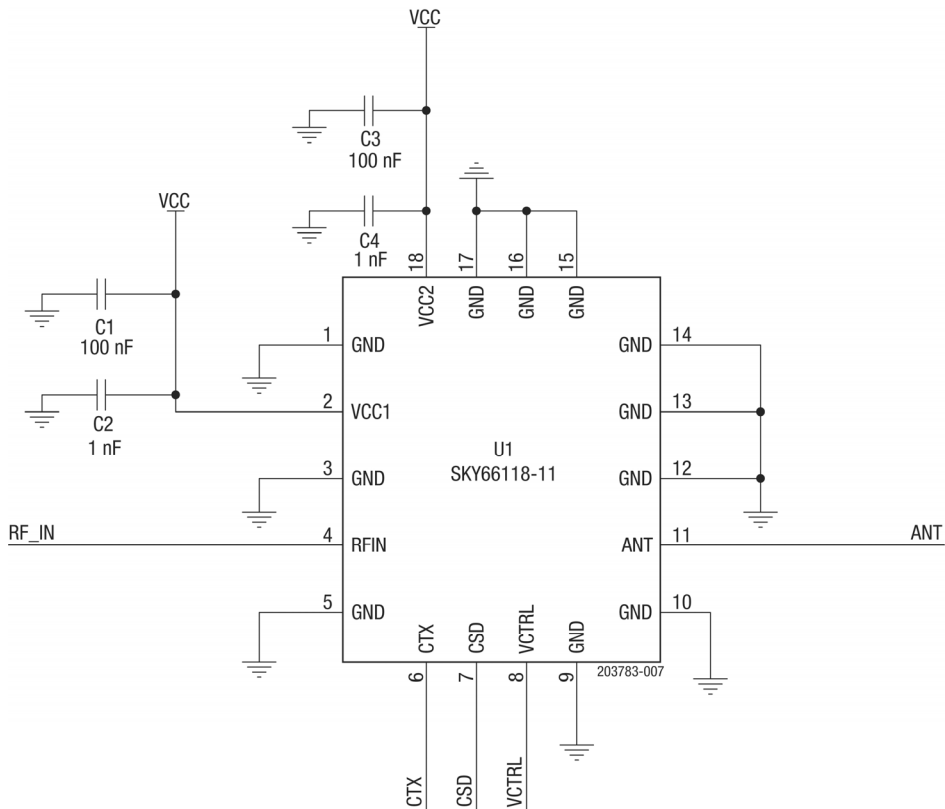
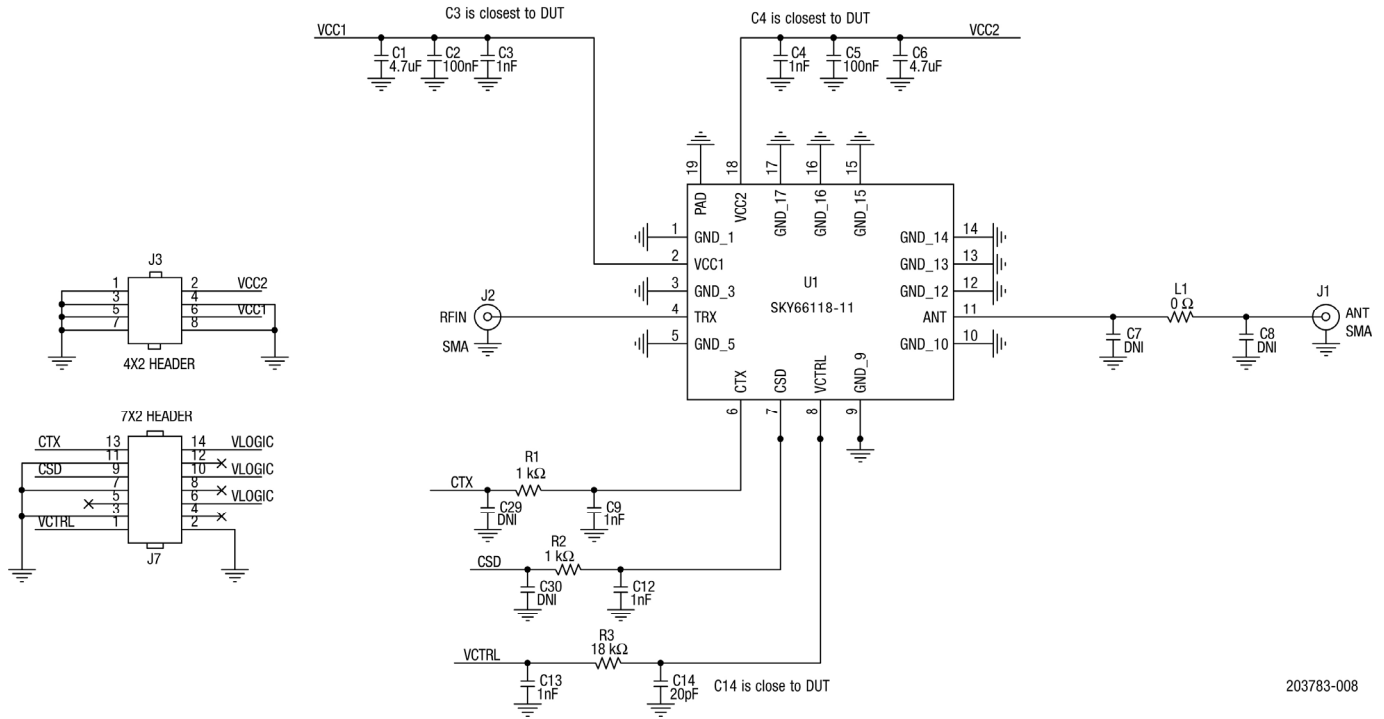

Figure 7. SKY66118-11 Reference Design Schematic

DATA SHEET • SKY66118-11: 2.4 GHz +20 dBm FRONT-END MODULE FOR BLUETOOTH IoT APPLICATIONS



203783-008

Figure 8. SKY66118-11 Evaluation Board Schematic Diagram

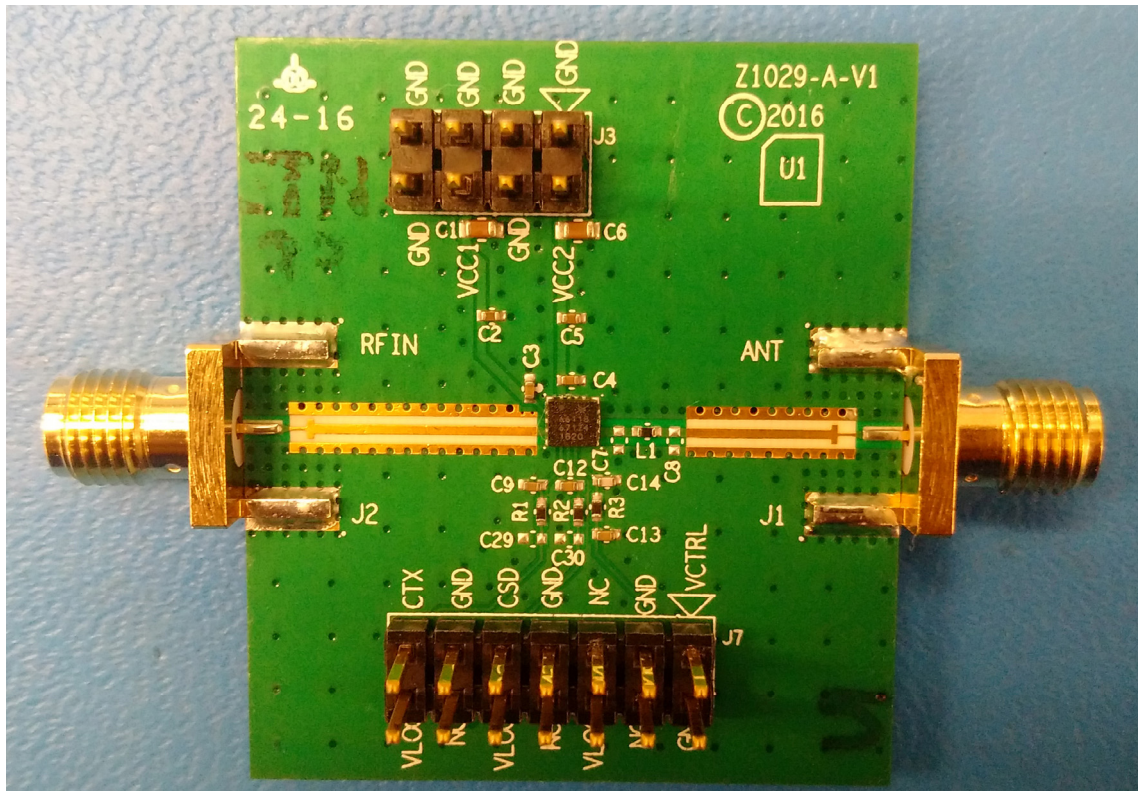

Figure 9. SKY66118-11 Evaluation Board Photograph

Table 7. SKY66118-11 Evaluation Board Bill of Materials (BOM)

Quantity	Reference	Value	Manufacturer	Mfr Part Number	Package
2	C1, C6	4.7 uF	Murata	GRM188C71A475KE11D	0603
2	C2, C5	100 nF	Murata	GRM155R71C104KA88D	0402
5	C3, C4, C9, C12, C13	1 nF	Murata	GRM155R71H102KA01	0402
4	C7, C8, C29, C30	DNI			0402
1	C14	20 pF	Murata	GJM1555C1H200GB01	0402
4	J1, J2	SMA	Johnson Components	142-0701-851	end launch
1	J3	4X2 HEADER	Samtec	TSW-104-07-G-D	100 mil
1	J7	7X2 HEADER	Samtec	TSW-107-07-G-D	100 mil
2	L1	0 Ω	Panasonic	ERJ2GE0R00	0402
1	PCB1	Z1029-A-V1			
2	R1, R2	1 kΩ	Panasonic	ERJ2GEJ102	0402
1	R3	18 kΩ	Panasonic	ERJ2GEJ183	0402
1	U1	SKY66118-11	Skyworks Solutions	SKY66118-11	MCM2.4X2.6

Package Dimensions

The PCB layout footprint for the SKY66118-11 is provided in Figure 10. The typical part marking is shown in Figure 11. Package dimensions are shown in Figure 12, and tape and reel dimensions are provided in Figure 13.

Package and Handling Information

Since the device package is sensitive to moisture absorption, it is baked and vacuum packed before shipping. Instructions on the shipping container label regarding exposure to moisture after the container seal is broken must be followed. Otherwise, problems related to moisture absorption may occur when the part is subjected to high temperature during solder assembly.

The SKY66118-11 is rated to Moisture Sensitivity Level 3 (MSL3) at 260 °C. It can be used for lead or lead-free soldering. For additional information, refer to the Skyworks Application Note, *PCB Design and SMT Assembly/Rework Guidelines for MCM-L Packages*, document number 101752.

Care must be taken when attaching this product, whether it is done manually or in a production solder reflow environment. Production quantities of this product are shipped in a standard tape and reel format.

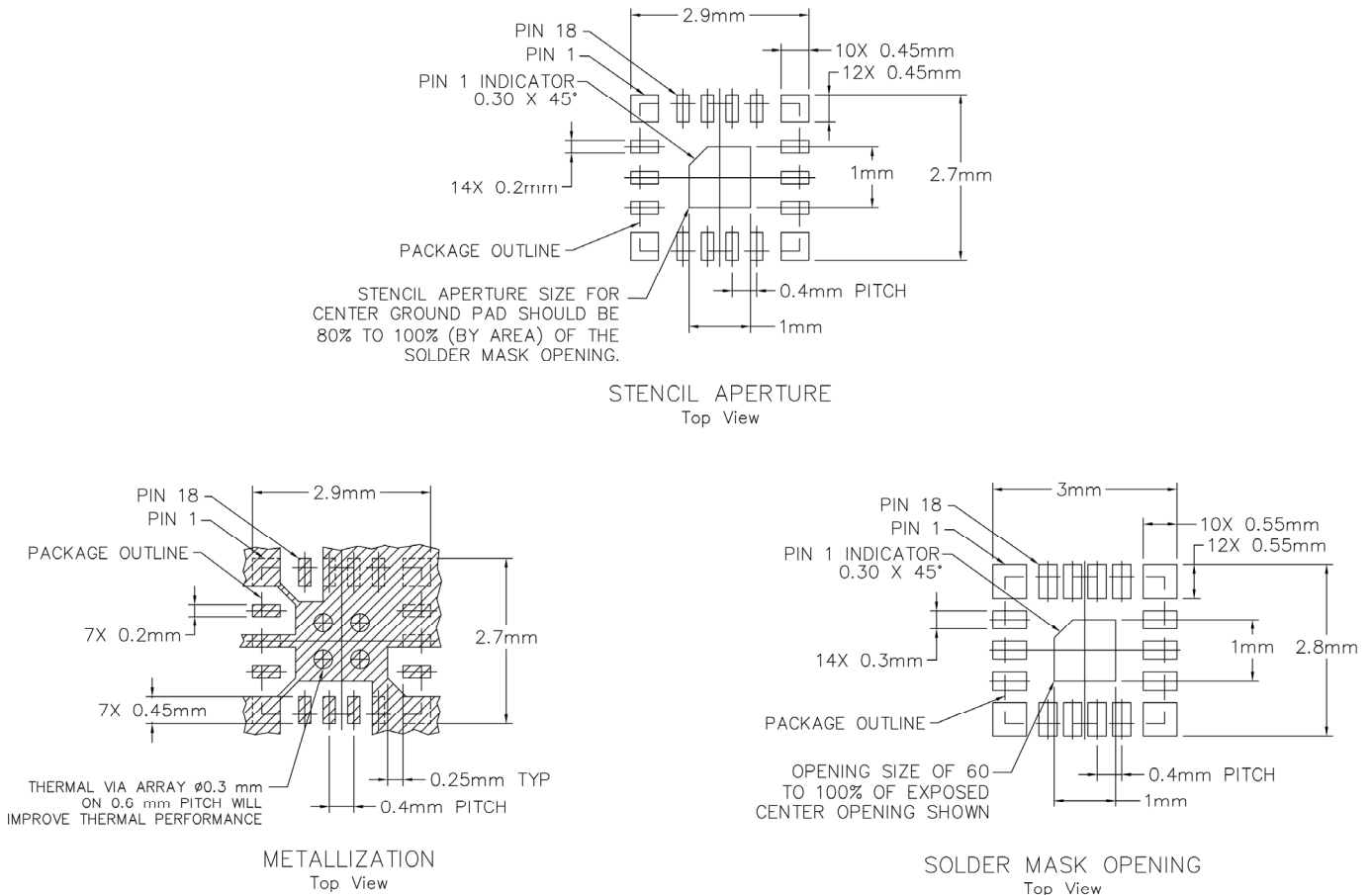

NOTE: THERMAL VIAS SHOULD BE RESIN FILLED AND CAPPED IN ACCORDANCE WITH IPC-4761 TYPE VII VIAS. 30-35UM CU THICKNESS IS RECOMMENDED.

203783-010

Figure 10. SKY66118-11 PCB Layout Footprint

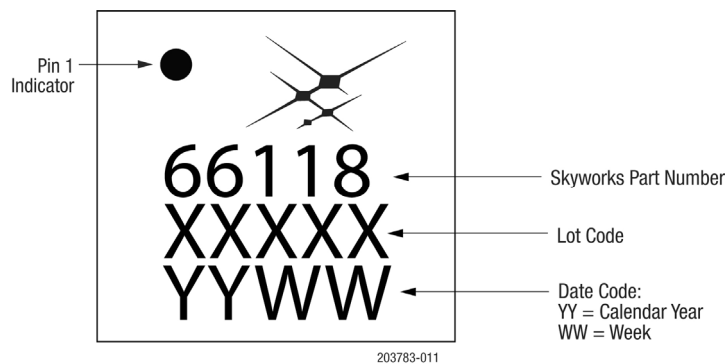
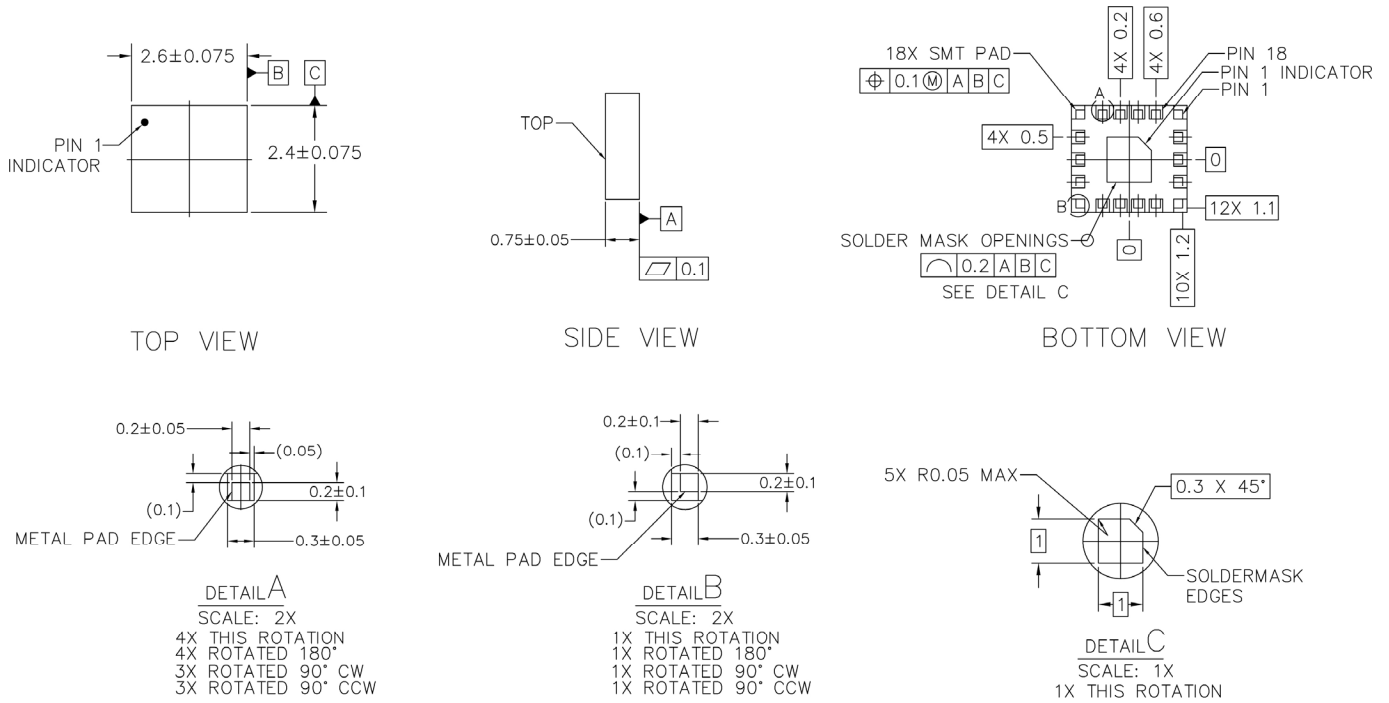

Figure 11. SKY66118-11 Typical Part Marking (Top View)

DATA SHEET • SKY66118-11: 2.4 GHz +20 dBm FRONT-END MODULE FOR BLUETOOTH IoT APPLICATIONS



NOTES: UNLESS OTHERWISE SPECIFIED.

1. DIMENSIONING AND TOLERANCING IN ACCORDANCE WITH ASME Y14.5M-1994.
2. DIMENSIONS ARE IN MILLIMETERS

203783-012

Figure 12. SKY66118-11 Package Dimensions

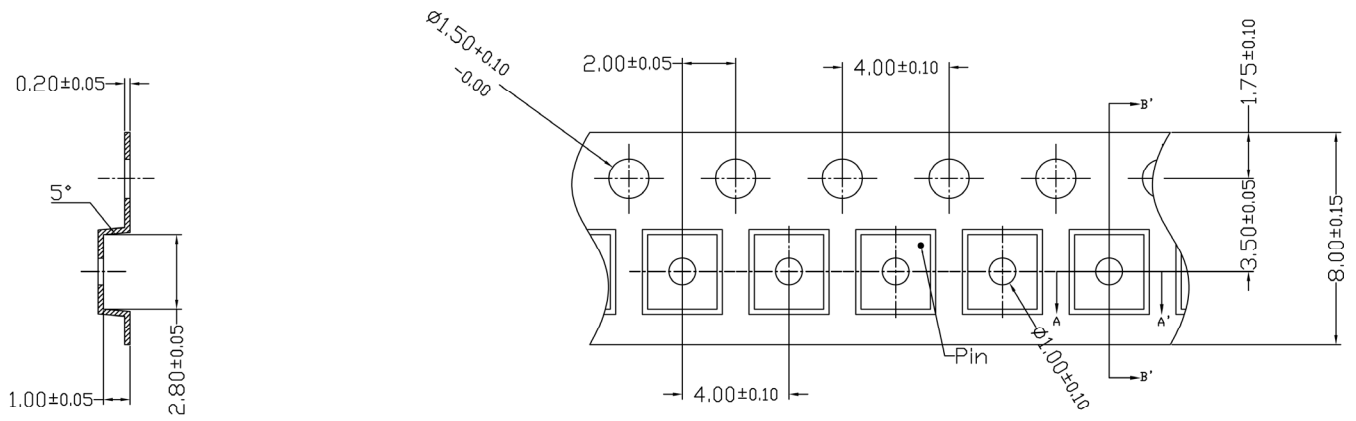

SECTION B-B'

1. CARRIER TAPE MUST MEET ALL SKYWORKS REQUIREMENTS OF GP01-D233 PROCUREMENT SPEC FOR TAPE AND REEL
- ② CARRIER TAPE SHALL BE BLACK CONDUCTIVE POLYCARBONATE NON BAKEABLE.
3. COVER TAPE SHALL BE TRANSPARENT CONDUCTIVE MATERIAL
4. ESD-SURFACE RESISTIVITY SHALL MEET GP01-D233
5. 10 SPROCKET HOLE PITCH CUMULATIVE TOLERANCE : ± 0.20 mm
6. A_o & B_o MEASURED ON PLANE 0.30mm ABOVE THE BOTTOM OF THE POCKET.
7. ALL DIMENSIONS ARE IN MILLIMETERS.

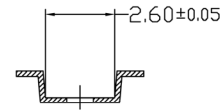

SECTION A-A'

Figure 13. SKY66118-11 Tape and Reel Dimensions

203783-013

Ordering Information

Part Number	Product Description	Evaluation Board Part Number
SKY66118-11	2.4 GHz +20 dBm Front-End Module for Bluetooth IoT Applications	SKY66118-11EK1

Copyright © 2016, 2018-2019 Skyworks Solutions, Inc. All Rights Reserved.

Information in this document is provided in connection with Skyworks Solutions, Inc. ("Skyworks") products or services. These materials, including the information contained herein, are provided by Skyworks as a service to its customers and may be used for informational purposes only by the customer. Skyworks assumes no responsibility for errors or omissions in these materials or the information contained herein. Skyworks may change its documentation, products, services, specifications or product descriptions at any time, without notice. Skyworks makes no commitment to update the materials or information and shall have no responsibility whatsoever for conflicts, incompatibilities, or other difficulties arising from any future changes.

No license, whether express, implied, by estoppel or otherwise, is granted to any intellectual property rights by this document. Skyworks assumes no liability for any materials, products or information provided hereunder, including the sale, distribution, reproduction or use of Skyworks products, information or materials, except as may be provided in Skyworks Terms and Conditions of Sale.

THE MATERIALS, PRODUCTS AND INFORMATION ARE PROVIDED "AS IS" WITHOUT WARRANTY OF ANY KIND, WHETHER EXPRESS, IMPLIED, STATUTORY, OR OTHERWISE, INCLUDING FITNESS FOR A PARTICULAR PURPOSE OR USE, MERCHANTABILITY, PERFORMANCE, QUALITY OR NON-INFRINGEMENT OF ANY INTELLECTUAL PROPERTY RIGHT; ALL SUCH WARRANTIES ARE HEREBY EXPRESSLY DISCLAIMED. SKYWORKS DOES NOT WARRANT THE ACCURACY OR COMPLETENESS OF THE INFORMATION, TEXT, GRAPHICS OR OTHER ITEMS CONTAINED WITHIN THESE MATERIALS. SKYWORKS SHALL NOT BE LIABLE FOR ANY DAMAGES, INCLUDING BUT NOT LIMITED TO ANY SPECIAL, INDIRECT, INCIDENTAL, STATUTORY, OR CONSEQUENTIAL DAMAGES, INCLUDING WITHOUT LIMITATION, LOST REVENUES OR LOST PROFITS THAT MAY RESULT FROM THE USE OF THE MATERIALS OR INFORMATION, WHETHER OR NOT THE RECIPIENT OF MATERIALS HAS BEEN ADVISED OF THE POSSIBILITY OF SUCH DAMAGE.

Skyworks products are not intended for use in medical, lifesaving or life-sustaining applications, or other equipment in which the failure of the Skyworks products could lead to personal injury, death, physical or environmental damage. Skyworks customers using or selling Skyworks products for use in such applications do so at their own risk and agree to fully indemnify Skyworks for any damages resulting from such improper use or sale.

Customers are responsible for their products and applications using Skyworks products, which may deviate from published specifications as a result of design defects, errors, or operation of products outside of published parameters or design specifications. Customers should include design and operating safeguards to minimize these and other risks. Skyworks assumes no liability for applications assistance, customer product design, or damage to any equipment resulting from the use of Skyworks products outside of stated published specifications or parameters.

Skyworks and the Skyworks symbol are trademarks or registered trademarks of Skyworks Solutions, Inc. or its subsidiaries in the United States and other countries. Third-party brands and names are for identification purposes only, and are the property of their respective owners. Additional information, including relevant terms and conditions, posted at www.skyworksinc.com, are incorporated by reference.

X-ON Electronics

Largest Supplier of Electrical and Electronic Components

Click to view similar products for [Bluetooth Development Tools - 802.15.1 category:](#)

Click to view products by [Skyworks manufacturer:](#)

Other Similar products are found below :

[DA14580PRODTLKT](#) [1628](#) [MBH7BLZ02-EF-KIT](#) [CYBLE-014008-PROG](#) [FWM7BLZ20-EB-KIT](#) [ATSAMB11ZR-XPRO](#) [SKY66111-21EK1](#) [SECO-RSL10-TAG-GEVB](#) [ENW89857AXKF](#) [3026](#) [MIKROE-2471](#) [MOD-NRF8001](#) [BLE-IOT-GEVB](#) [450-0184](#) [MIKROE-2399](#) [EKSHCNZXZ](#) [EVAL_PAN1026](#) [EVAL_PAN1720](#) [EVAL_PAN1740](#) [2267](#) [2479](#) [2487](#) [2633](#) [STEVAL-IDB005V1D](#) [STEVAL-IDB001V1](#) [MIKROE-2545](#) [SIPKITSLF001](#) [2995](#) [STEVAL-IDB007V1M](#) [2829](#) [DFR0267](#) [DFR0296](#) [DFR0492](#) [TEL0073](#) [BM-70-CDB](#) [WSM-BL241-ADA-008DK](#) [STEVAL-BTDP1](#) [ACD52832](#) [TEL0095](#) [ISP1507-AX-TB](#) [RN-4871-PICTAIL](#) [DA14695-00HQDEVKT-P](#) [DA14695-00HQDEVKT-U](#) [EVK-NINA-B112](#) [EBSHJNZXZ](#) [EKSGJNZWY](#) [EKSHJNZXZ](#) [BMD-200-EVAL-S](#) [ACN BREAKOUT BOARD](#) [ACN SKETCH](#)