

DATA SHEET

SKY66407-11: 2.4 GHz Low-Power, Low-Profile Front-End Module for Bluetooth® IoT Applications

Applications

- Wearables
- Trackers
- Beacons
- Sensor networks
- Home automation
- Internet of Things (IoT) devices

Features

- Adjustable gain, output power, and current consumption
- Max BT EDR output power: +11.5 dBm
- Wide supply range: 1.7 to 3.6 V
- High ESD rating: 2 kV
- Low sleep current: < 1 uA
- Low Rx bypass loss
- Small CSP (9-pin, 1.2 x 1.2 x 0.35 mm) package (MSL1, 260 °C per JEDEC-J-STD-020)



Skyworks Green™ products are compliant with all applicable legislation and are halogen-free. For additional information, refer to *Skyworks Definition of Green™*, document number SQ04-0074.

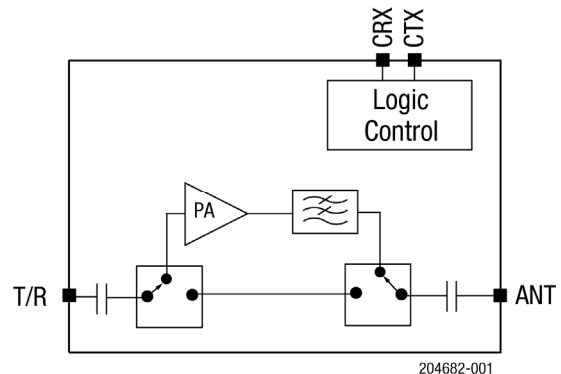

Figure 1. SKY66407-11 Functional Block Diagram

Description

The SKY66407-11 is a highly integrated front-end module (FEM) designed for Bluetooth IoT applications operating in the 2.4 to 2.4835 GHz range.

The device is provided in a 1.2 x 1.2 x 0.35 mm 9-pin CSP package. A functional block diagram is shown in Figure 1. Pin assignments are shown in Figure 2. Signal pin assignments and functional pin descriptions are provided in Table 1.

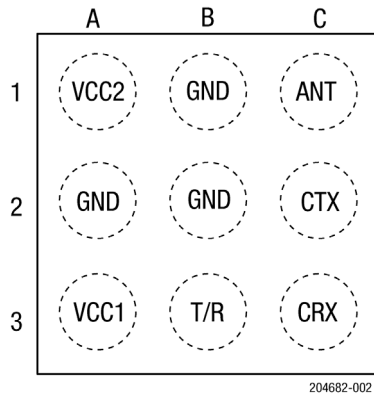

Figure 2. SKY66407-11 Pinout (Top View)

Table 1. SKY66407-11 Signal Descriptions

Bump	Name	Description	Bump	Name	Description
A1	VCC2	Positive power supply	B3	T/R	Connect to 50 Ω transceiver output
A2	GND	Ground	C1	ANT	Connect to 50 Ω antenna
A3	VCC1	Positive power supply	C2	CTX	Tx control signal
B1	GND	Ground	C3	CRX	RX control signal
B2	GND	Ground			

Electrical and Mechanical Specifications

The absolute maximum ratings of the SKY66407-11 are provided in Table 2. The recommended operating conditions are specified in Table 3.

Electrical specifications are provided in Tables 4 through 6.

Table 2. SKY66407-11 Absolute Maximum Ratings¹

Parameter	Symbol	Minimum	Maximum	Units
Supply voltage	VCC1, VCC2	0.3	4.0	V
Control voltages	CTX, CRX	0.3	4.0	V
Transmit input power at T/R port	PIN_TX		+8	dBm
Receive input power at ANT port ²	PIN_RX		+20	dBm
Voltage standing wave ratio	VSWR		10:1	
Operating temperature	TA	-40	+105	°C
Storage temperature	TSTG	-40	+125	°C
Electrostatic discharge: Human Body Model (HBM), Class 2	ESD		2000	V

¹ Exposure to maximum rating conditions for extended periods may reduce device reliability. There is no damage to device with only one parameter set at the limit and all other parameters set at or below their nominal value. Exceeding any of the limits listed here may result in permanent damage to the device.

² CW test signal.

ESD HANDLING: *Although this device is designed to be as robust as possible, electrostatic discharge (ESD) can damage this device. This device must be protected at all times from ESD when handling or transporting. Static charges may easily produce potentials of several kilovolts on the human body or equipment, which can discharge without detection. Industry-standard ESD handling precautions should be used at all times.*

Table 3. Recommended Operating Conditions

Parameter	Symbol	Min	Typ	Max	Units
Supply voltage	VCC1, VCC2	1.7	3.3	3.6	V
Control voltages	CTX	1.0	1.8	2.2	V
Operating temperature	TA	-40	+25	+85	°C

Table 4. SKY66407-11 DC Electrical Specifications¹

(VCC1 = VCC2 = 3.3 V, CTX = 1.8 V, TA = +25 °C, Characteristic Impedance [Zo] = 50 Ω, Unless Otherwise Noted)

Parameter	Symbol	Test Condition	Min	Typ	Max	Units
Transmit operating current	ICC_TX	TX mode (PIN = 0 dBm):				
		VCC2 = 1.8 V		13		mA
		VCC2 = 3.3 V		16		mA
		VCC2 = 3.6 V		17		mA
Transmit quiescent current	ICQ_TX	TX mode		8		mA
Receive (bypass) current ²	ICC_RX	RX mode		4.0		µA
Sleep mode current	ICC_OFF	Sleep mode		0.1	1	µA
Logic Characteristics						
Control voltage:	VIH VIL		1.6 0		VCC1 0.3	V V
Tx bias current (CTX pin)	IBIAS_TX			30		µA
Rx control current (CRX pin)	IBIAS_RX			1.0		µA

¹ Performance is guaranteed only under the conditions listed in this table.

² The current will be the same as sleep current if logic high levels are equal to VCC1.

Table 5. SKY66407-11 AC Electrical Specifications¹
(Vcc1 = Vcc2 = 3.3 V, CTX = 1.8 V, TA = +25 °C, PIN = 0 dBm, Characteristic Impedance [Zo] = 50 Ω, Unless Otherwise Noted)

Parameter	Symbol	Test Condition	Min	Typ	Max	Units
Transmit Characteristics						
Frequency range	f		2400		2483.5	MHz
Output power	POUT	VCC2 = 1.8 V BDR		+9.5		dBm
		VCC2 = 3.3 V BDR		+12		dBm
		VCC2 = 3.6 V BDR		+12.5		dBm
		VCC2 = 3.3 V EDR-3		+10.0 ²		dBm
		VCC2 = 3.6 V EDR-3		+10.5 ²		dBm
Saturated gain ³	G_SAT	PIN = 0 dBm		12		dB
Small signal gain	S21_TX	PIN = -25 dBm		13		dB
Gain slope	GSLOPE	Over frequency range			1	dBp-p
Input return loss ³	S11_TX	T/R port		-10		dB
Output return loss ³	S22_TX	ANT port		-12		dB
2 nd harmonic ³	2fo	POUT = +10 dBm, CW signal source			-40	dBm/MHz
3 rd harmonic ³	3fo	POUT = +10 dBm, CW signal source			-30	dBm/MHz
TX turn-on time ³	tON_TX	50% VCTX to 90% RF		800		ns
TX turn-off time ³	tOFF_TX	50% VCTX to 10% RF		200		ns
Stability ³	STAB	CW, PIN = 0 dBm, 0 GHz to 20 GHz, load VSWR = 6:1	All non-harmonically related outputs < -42 dBm/MHz			
Ruggedness ³	RUG	CW, PIN = 0 dBm, load VSWR = 10:1	No permanent damage			
Receive Characteristics						
Frequency range	f		2400		2483.5	MHz
Insertion loss	S21_RX			-1.0		dB
Input return loss ³	S11_RX	ANT port		-15		dB
Output return loss ³	S22_RX	T/R port		-15		dB
RX turn-on time ³	tON_RX	50% VCRX to 90% RF		800		ns
RX turn-off time ³	tOFF_RX	50% VCRX to 10% RF		200		ns

¹ Performance is guaranteed only under the conditions listed in this table.

² Refer to Bluetooth EDR section for higher output power operation.

³ Guaranteed by characterization.

Table 6. SKY66407-11 Mode Logic Truth Table

Mode	CTX	CRX
Sleep mode	0	0
Receive (RX) mode	0	1
Transmit (TX) mode	1	X

CTX Pin Usage

The SKY66407-11 CTX pin supplies the bias to the internal PA. By varying the voltage at this pin, PA operating parameters including gain, supply current, and efficiency can be adjusted.

The CTX pin can also be used to adjust the SKY66407-11 output power when the RF source (transceiver or baseband) has a fixed level. Figure 3 shows the output power vs CTX level at different input power, while Figures 4 through 12 show the gain, current, and PAE performance vs CTX at different output power.

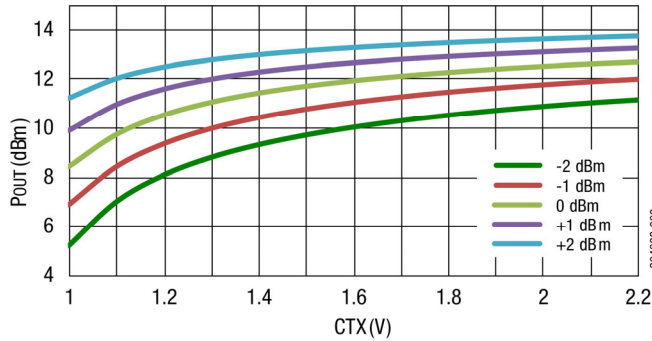

Figure 3. Pout vs CTX and Pin
(Vcc = 3.3 V, f = 2440 MHz)

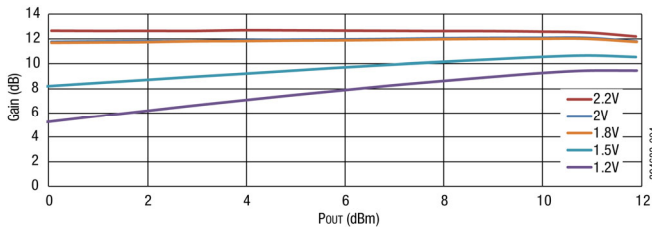

Figure 4. Gain vs Pout and CTX
(Vcc = 3.3 V, f = 2440 MHz @ 25 °C)

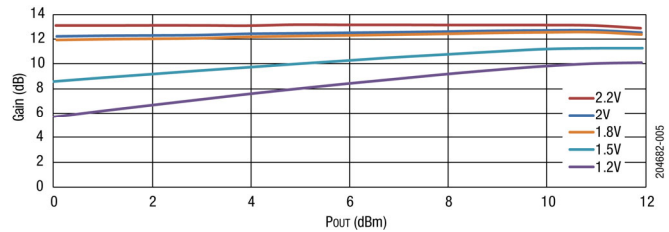

Figure 5. Gain vs Pout and CTX
(Vcc = 3.3 V, f = 2440 MHz = 3.3 V @ -20 °C)

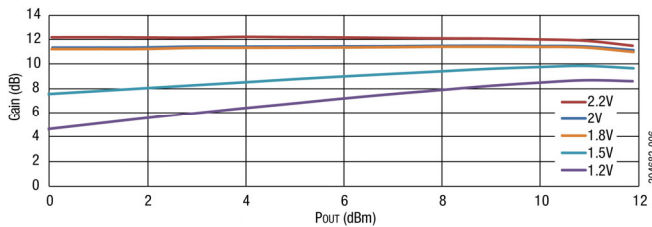

Figure 6. Gain vs Pout and CTX
(Vcc = 3.3 V, f = 2440 MHz = 3.3 V @ +60 °C)

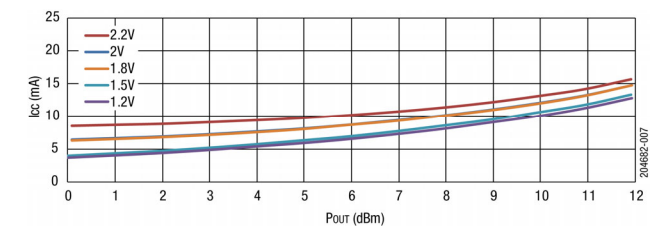

Figure 7. Icc vs Pout and CTX
(Vcc = 3.3 V, f = 2440 MHz @ 25 °C)

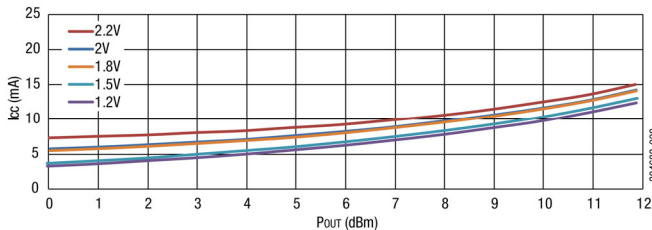

Figure 8. Icc vs Pout and CTX
(Vcc = 3.3 V, f = 2440 MHz V @ -20 °C)

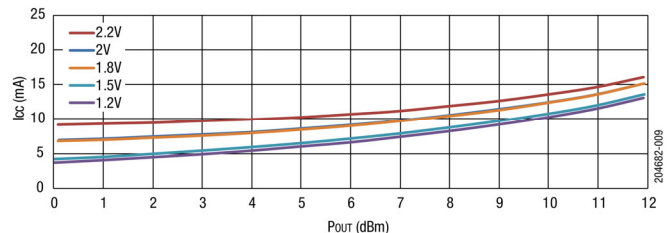

Figure 9. Icc vs Pout and CTX and Pin
(Vcc = 3.3 V, f = 2440 MHz @ +60 °C)

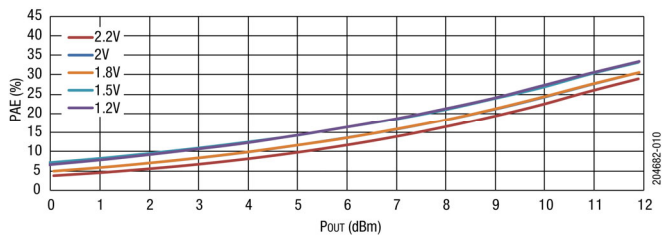

Figure 10. PAE vs Pout and CTX
(Vcc = 3.3 V, f = 2440 MHz @ 25 °C)

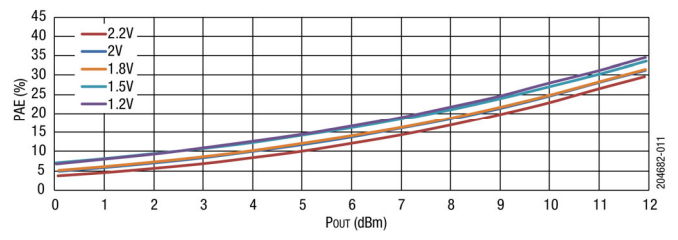

Figure 11. PAE vs Pout and CTX
(Vcc = 3.3 V, f = 2440 MHz @ -20 °C)

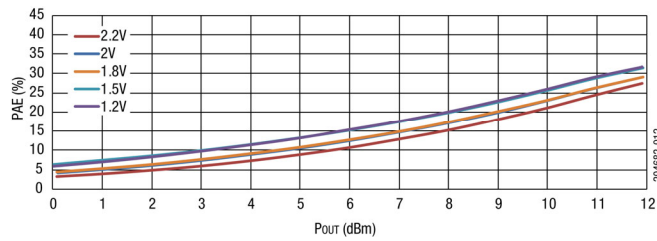

Figure 12. PAE vs Pout and CTX
(Vcc = 3.3 V, f = 2440 MHz @ +60 °C)

In many applications, a variable DC supply voltage may not be available. The desired bias voltage can be generated by connecting CTX to the GPIO controlling CTX with a resistor (refer to Figure 13). With no RF input, the CTX pin draws very little current. Toggling the CTX from the GPIO also causes the PA to

turn off when CTX is pulled low, reducing the RX and shutdown mode current.

Table 7 lists the relationship between CTX voltage/current and bias resistance.

Table 7. V_{CTX} Voltage and Current vs Bias Resistance (V_{CC} = 3.3 V)

R _{BIAS} (kΩ)	CTX (V)	I _{CTX} (μA)	ICC (mA)
22	2.2	58	12.9
27	2.1	55	11.5
32	2	50	10.2
39	1.9	46	8.9
47	1.8	40	7.6
59	1.7	36	6.4
76	1.6	32	5.2
99	1.5	28	4.1
133	1.4	24	3.1
200	1.3	20	2.1
310	1.2	16	1.3
600	1.1	14	0.7

If a fixed CTX voltage (for example, from an LDO) is available in the application circuit, using this instead of a resistor reduces the variation of output power with V_{CC}. To minimize SKY66407-11

current consumption in RX bypass and shutdown modes, the voltage to the CTX pin should be switched off when the CTX is logic low.

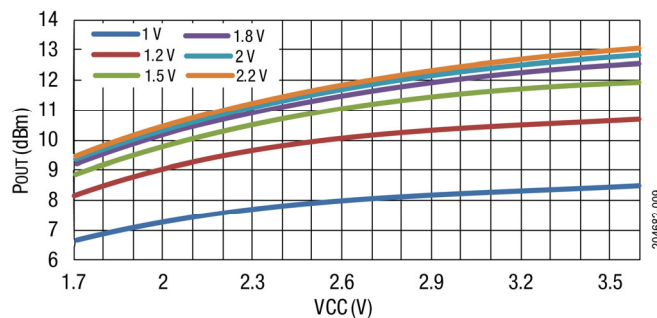

Figure 13. P_{out} vs V_{CC} and CTX (P_{IN} = 0 dBm, f = 2440 MHz)

Bluetooth EDR Adjacent Channel Power

The SKY66407-11 benefits from excellent adjacent channel power (ACP) performance in Bluetooth EDR applications.

Typical ACP measurements for EDR modulations ($\pi/4$ -DQPSK with 2-DH5 packets) are shown in Figures 14 through 17 (Note: VCC = 3.3 V, VCTX = 1.8 V, f = 2440 MHz).

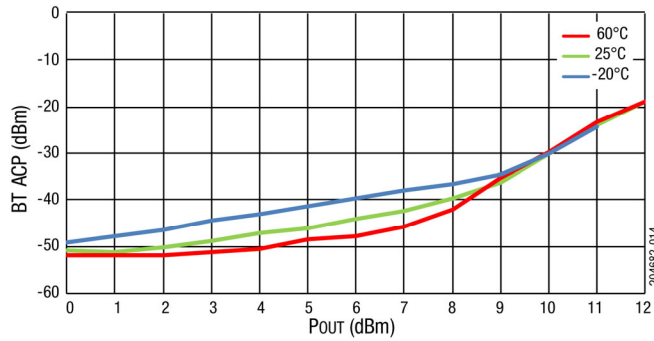

Figure 14. BT ACP CH+2 vs POUT, BT-EDR-2DH5

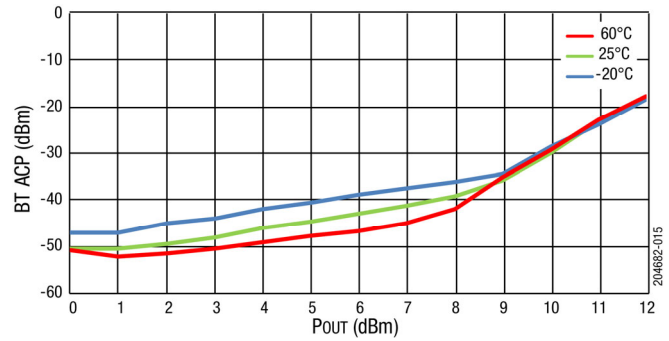

Figure 15. BT ACP CH-2 vs POUT, BT-EDR-2DH5

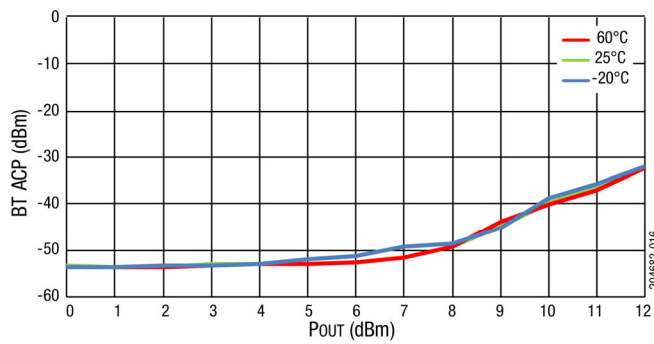

Figure 16. BT ACP CH+3 vs POUT, BT-EDR-2DH5

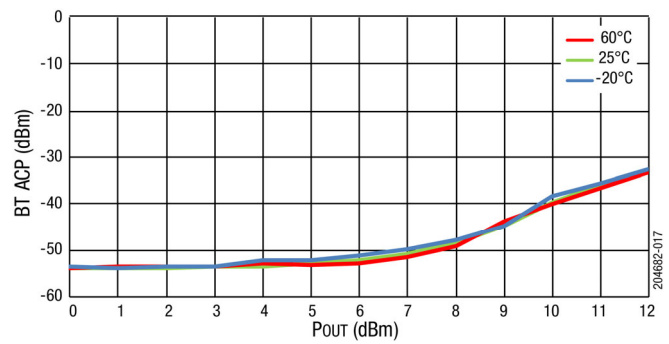

Figure 17. BT ACP CH-3 vs POUT, BT-EDR-2DH5

Evaluation Board Description

The SKY66407-11 Evaluation Board is used to test the performance of the SKY66407-11 front-end module. The board is optimized for evaluation, experimentation, and investigation with a BLE or 802.15.4 signal source. The design and layout can be quickly and easily transferred into a production design.

A reference design schematic is provided in Figure 18. An Evaluation Board schematic diagram is provided in Figure 19. A photograph of the Evaluation Board is shown in Figure 20. The Evaluation Board Bill of Materials (BoM) is listed in Table 8.

Evaluation Board Setup Procedure

1. Connect system ground to pin 1 of the J3 header.
2. Apply 3.3 V to pin 2 of the J3 header.
3. Select a path according to the information in Table 6 (L = 0 V, H = 3.3 V) using pin 6 (VCTX) and pin 10 (VCRX) of the J3 header.

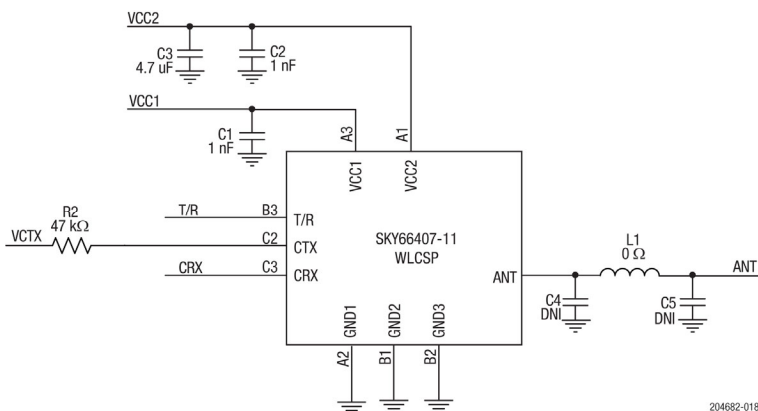

Figure 18. SKY66407-11 Reference Design Schematic

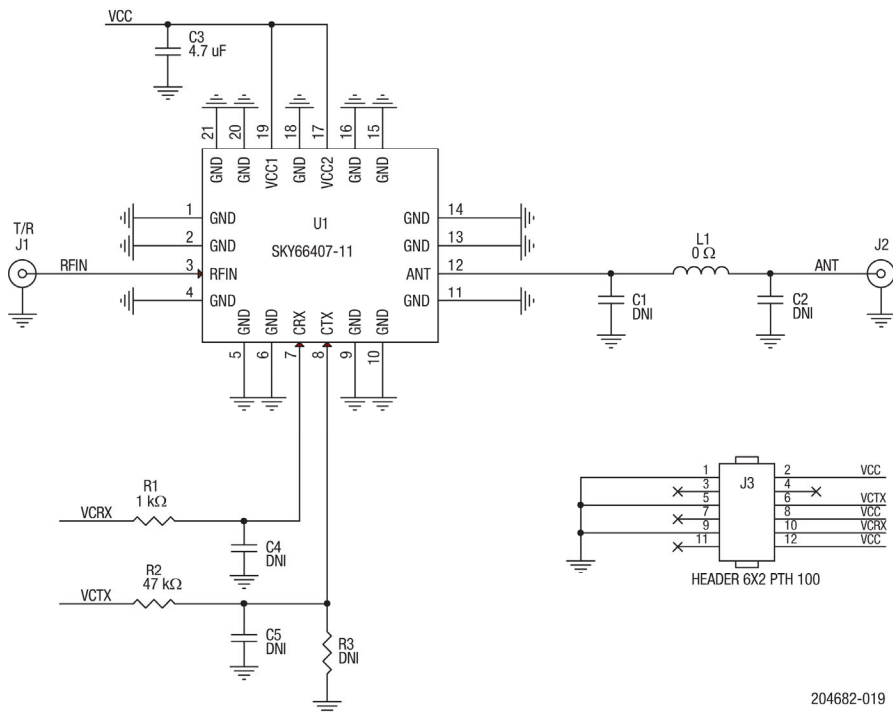

Figure 19. SKY66407-11 Evaluation Board Schematic

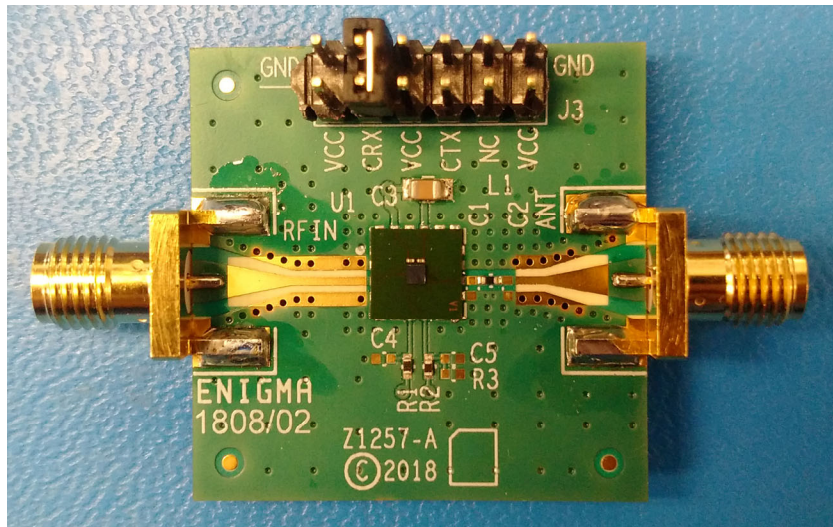

Figure 20. SKY66407-11 Evaluation Board

Table 8. SKY66407-11 Evaluation Board Bill of Materials (BoM)

Reference	Value	Manufacturer	Mfr Part Number	Package	Description
C1, C2, R3, C4, C5	DNI			0402	DNI
C3	4.7 uF	muRata	GRM21BR71C475KA73L	0805	Ceramic capacitor, 4.7 uF, 16 V, X7R
J1, J2	SMA	Johnson Components	142-0701-851	End Launch	Connector SMA jack, STR, 50 Ω, edge mount
J3	Header 6X2 PTH 100	Samtec	TSW-106-07-G-D		Connector header, 12 POS, 100" DL gold
L1	0 Ω			0402	
PCB1	Z1257-A	Skyworks	Z1257-A		PCB
R1	1 kΩ	Panasonic	ERJ-PA2F1001X	0402	Resistor, SMD, 1 kΩ, 1%, 1/5 W
R2	47 kΩ	Multi-vendor	5424R27-134	0402	Resistor, 47 kΩ, jumper, 0.063 W
U1	SKY66407-11 CSP	Skyworks Solutions			

Package Dimensions

The PCB layout footprint for the SKY66407-11 is provided in Figure 21. The typical part marking is shown in Figure 22. Package dimensions are shown in Figure 23, and tape and reel dimensions are provided in Figure 24.

Package and Handling Information

Instructions on the shipping container label regarding exposure to moisture after the container seal is broken must be followed. Otherwise, problems related to moisture absorption may occur when the part is subjected to high temperature during solder assembly.

The SKY66407-11 is rated to Moisture Sensitivity Level 1 (MSL1) at 260 °C. It can be used for lead or lead-free soldering.

Care must be taken when attaching this product, whether it is done manually or in a production solder reflow environment. Production quantities of this product are shipped in a standard tape and reel format.

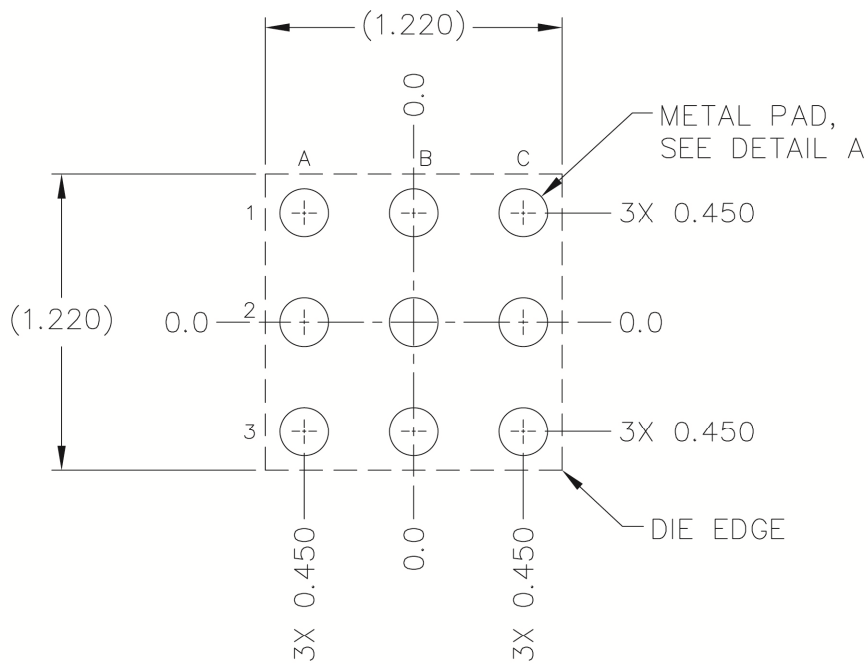

TOP VIEW

(THRU WLCSP DIE, BUMP SIDE DOWN)

NOTES:

1. ALL DIMENSIONS ARE IN MILLIMETERS.
2. DIMENSIONING AND TOLERANCING PER ASME Y14.5M-1994.
3. UNLESS SPECIFIED DIMENSIONS ARE SYMMETRICAL ABOUT CENTER LINES.
4. TOLERANCING (UNLESS OTHERWISE SPECIFIED).

DECIMAL TOLERANCE:

- X.X (1 PLC) ± 0.1mm
- X.XX (2 PLC) ± 0.05mm
- X.XXX (3 PLC) ± 0.025mm

ANGULAR TOLERANCE:

± 1/2°

DETAIL A

(2X SCALE)
9 PLCS

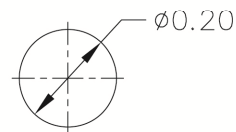

204682-021

Figure 21. PCB Layout Footprint

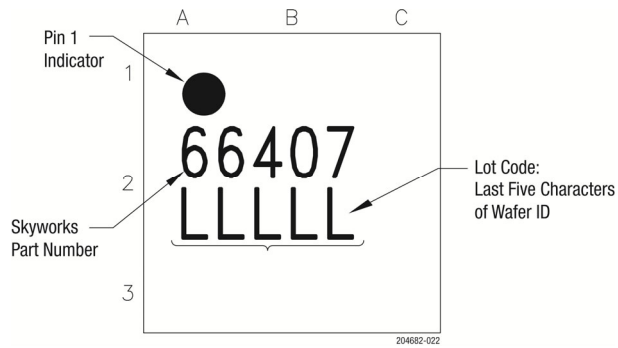
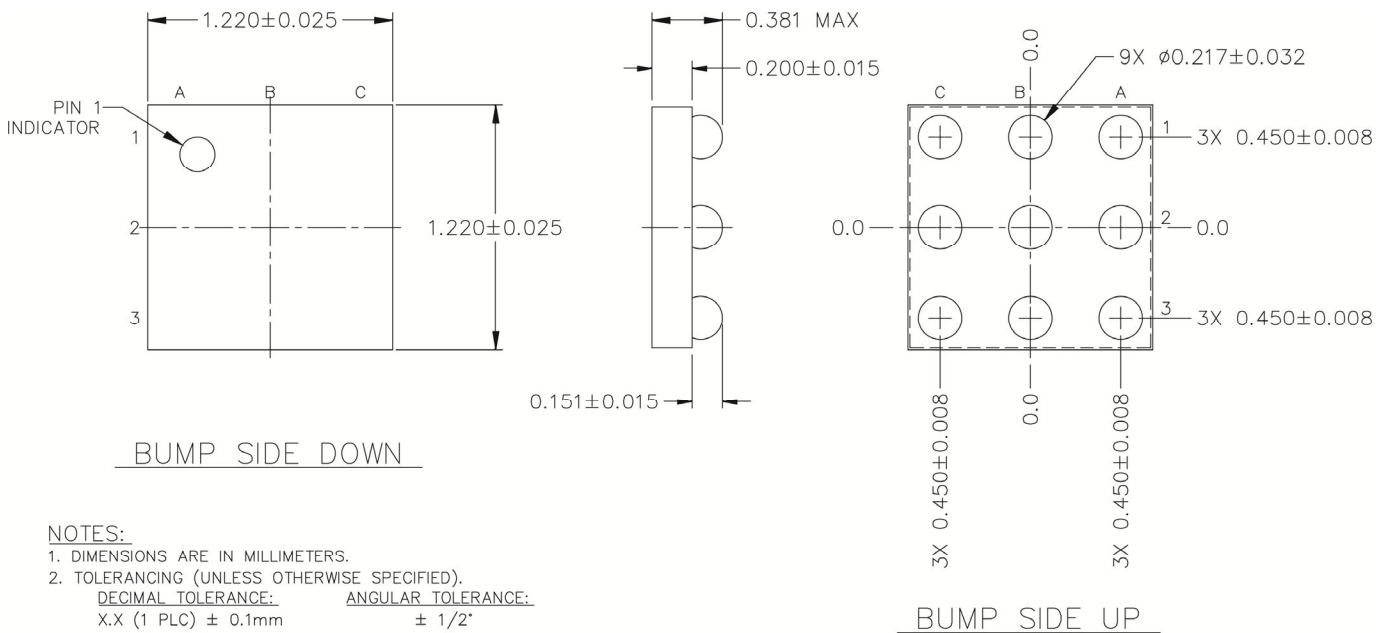

Figure 22. Typical Part Marking



NOTES:

1. DIMENSIONS ARE IN MILLIMETERS.
2. TOLERANCING (UNLESS OTHERWISE SPECIFIED).

DECIMAL TOLERANCE:	ANGULAR TOLERANCE:
X.X (1 PLC) ± 0.1mm	± 1/2°
X.XX (2 PLC) ± 0.05mm	
X.XXX (3 PLC) ± 0.025mm	
3. UNLESS SPECIFIED DIMENSIONS ARE SYMMETRICAL ABOUT CENTER LINES.

204682-023

Figure 23. SKY66407-11 Package Dimensions

DATA SHEET • SKY66407-11: 2.4 GHz Low-Power, Low-Profile FEM for Bluetooth IoT Applications

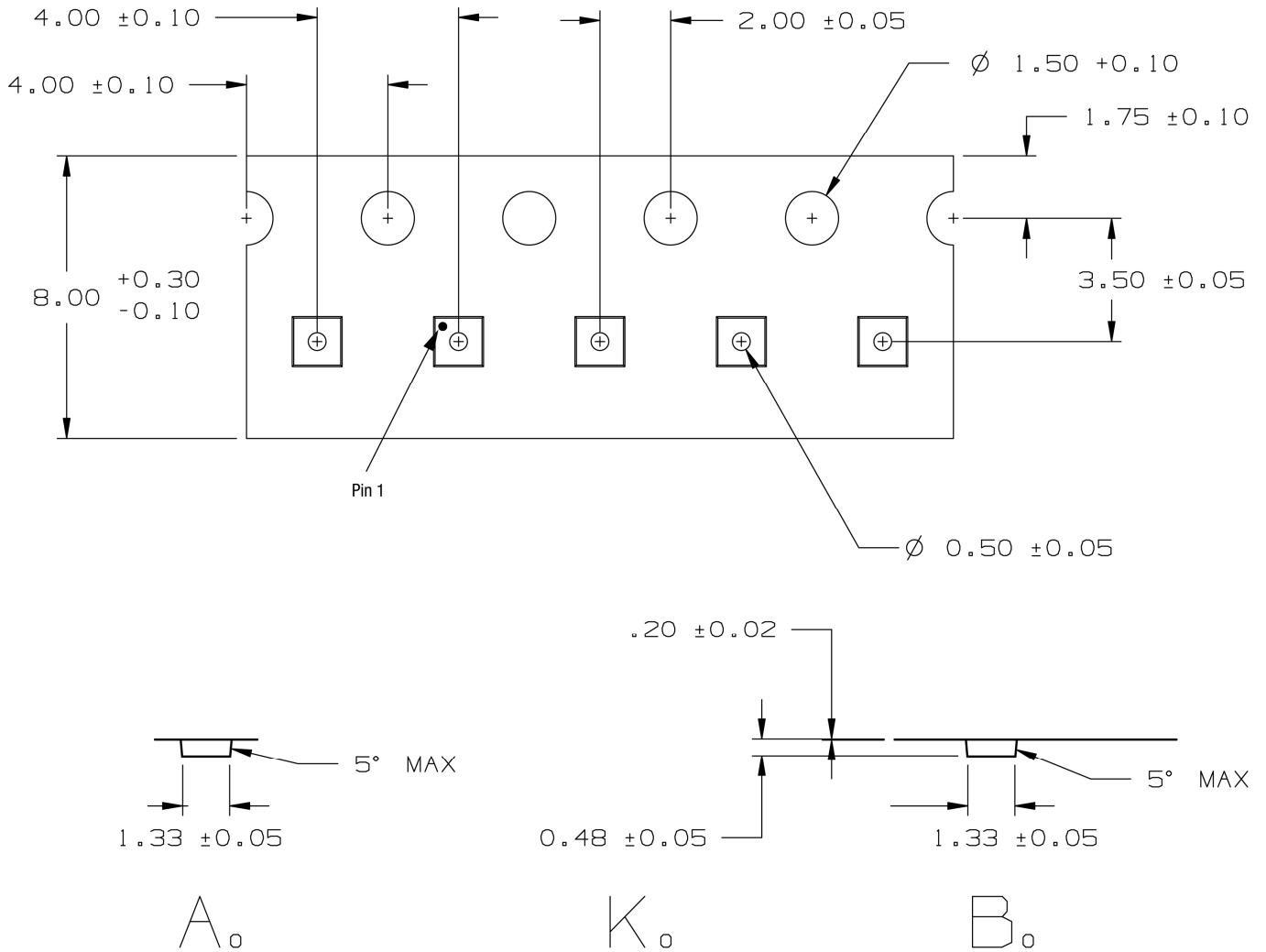

All dimensions are in millimeters.

204682-024

Figure 24. SKY66407-11 Tape and Reel Dimensions

Ordering Information

Part Number	Product Description	Evaluation Board Part Number
SKY66407-11	2.4 GHz Low-Power, Low-Profile FEM for Bluetooth IoT Applications	SKY66407-11EK1

Copyright © 2017-2020 Skyworks Solutions, Inc. All Rights Reserved.

Information in this document is provided in connection with Skyworks Solutions, Inc. (“Skyworks”) products or services. These materials, including the information contained herein, are provided by Skyworks as a service to its customers and may be used for informational purposes only by the customer. Skyworks assumes no responsibility for errors or omissions in these materials or the information contained herein. Skyworks may change its documentation, products, services, specifications or product descriptions at any time, without notice. Skyworks makes no commitment to update the materials or information and shall have no responsibility whatsoever for conflicts, incompatibilities, or other difficulties arising from any future changes.

No license, whether express, implied, by estoppel or otherwise, is granted to any intellectual property rights by this document. Skyworks assumes no liability for any materials, products or information provided hereunder, including the sale, distribution, reproduction or use of Skyworks products, information or materials, except as may be provided in Skyworks Terms and Conditions of Sale.

THE MATERIALS, PRODUCTS AND INFORMATION ARE PROVIDED “AS IS” WITHOUT WARRANTY OF ANY KIND, WHETHER EXPRESS, IMPLIED, STATUTORY, OR OTHERWISE, INCLUDING FITNESS FOR A PARTICULAR PURPOSE OR USE, MERCHANTABILITY, PERFORMANCE, QUALITY OR NON-INFRINGEMENT OF ANY INTELLECTUAL PROPERTY RIGHT; ALL SUCH WARRANTIES ARE HEREBY EXPRESSLY DISCLAIMED. SKYWORKS DOES NOT WARRANT THE ACCURACY OR COMPLETENESS OF THE INFORMATION, TEXT, GRAPHICS OR OTHER ITEMS CONTAINED WITHIN THESE MATERIALS. SKYWORKS SHALL NOT BE LIABLE FOR ANY DAMAGES, INCLUDING BUT NOT LIMITED TO ANY SPECIAL, INDIRECT, INCIDENTAL, STATUTORY, OR CONSEQUENTIAL DAMAGES, INCLUDING WITHOUT LIMITATION, LOST REVENUES OR LOST PROFITS THAT MAY RESULT FROM THE USE OF THE MATERIALS OR INFORMATION, WHETHER OR NOT THE RECIPIENT OF MATERIALS HAS BEEN ADVISED OF THE POSSIBILITY OF SUCH DAMAGE.

Skyworks products are not intended for use in medical, lifesaving or life-sustaining applications, or other equipment in which the failure of the Skyworks products could lead to personal injury, death, physical or environmental damage. Skyworks customers using or selling Skyworks products for use in such applications do so at their own risk and agree to fully indemnify Skyworks for any damages resulting from such improper use or sale.

Customers are responsible for their products and applications using Skyworks products, which may deviate from published specifications as a result of design defects, errors, or operation of products outside of published parameters or design specifications. Customers should include design and operating safeguards to minimize these and other risks. Skyworks assumes no liability for applications assistance, customer product design, or damage to any equipment resulting from the use of Skyworks products outside of stated published specifications or parameters.

Skyworks and the Skyworks symbol are trademarks or registered trademarks of Skyworks Solutions, Inc. or its subsidiaries in the United States and other countries. Third-party brands and names are for identification purposes only, and are the property of their respective owners. Additional information, including relevant terms and conditions, posted at www.skyworksinc.com, are incorporated by reference.

X-ON Electronics

Largest Supplier of Electrical and Electronic Components

Click to view similar products for [RF Front End](#) category:

Click to view products by [Skyworks](#) manufacturer:

Other Similar products are found below :

[SE2622L-R](#) [BGM1032N7E6327XUSA1](#) [LX5586LL](#) [SKY85703-11](#) [LX5586HLL](#) [LX5586ALL](#) [SKY66111-21](#) [SKY65728-11](#) [SKY68000-31](#)
[SKY85308-11](#) [SKY85302-11](#) [SKY65724-11](#) [ADTR1107ACCZ](#) [LMP91051MTX/NOPB](#) [SE5501L-R](#) [QPF4519SR](#) [SE5503A-R](#)
[ADA8282WBCPZ](#) [ADRF5545ABCPZN](#) [ADRF5545ABCPZN-R7](#) [AD8283WBCPZ](#) [AD8284WCSVZ](#) [ADRF5547BCPZN](#)
[ADRF5547BCPZN-R7](#) [ADRF5549BCPZN](#) [ADRF5549BCPZN-R7](#) [HV7350K6-G](#) [SE5516A-R](#) [MCP2030-I/SL](#) [MAX2009ETI+](#)
[MAX2078CTK+](#) [MAX2335ETI+](#) [MAX2678GTB/V+T](#) [MD2131K7-G](#) [MD2134K7-G](#) [RFFM6903TR13](#) [HV7351K6-G](#) [MCP2035-I/ST](#)
[SE2614BT-R](#) [SE2438T-R](#) [SST12LF02-QXCE](#) [SST12LF09-Q3CE](#) [RFX2401C](#) [RFX2402E](#) [SKY85201-11](#) [RFFM4591FTR7](#) [RFFM8211TR7](#)
[RFFM4293TR7](#) [RFFM4203TR7](#) [RFFM5765QTR7](#)