



DATA SHEET

# SKY67103-396LF: 0.5 to 4.0 GHz High Linearity, Active Bias Low-Noise Amplifier

## Applications

- LTE, GSM, WCDMA, HSDPA macro base stations
- Small cells
- Cellular repeaters, DAS, and RRH/RRUs
- 0.5 to 4.0 GHz low-noise receivers
- High-temperature receiver applications to +105 °C
- Improved high-frequency performance and footprint compatible with several industry standard low-noise amplifiers

## Features

- High gain:
  - 25 dB @ 0.85 GHz
  - 20 dB @ 1.85 GHz
  - 18.2 dB @ 2.6 GHz
  - 16.5 dB @ 3.6 GHz
- Low noise figure:
  - 0.5 dB @ 0.85 GHz
  - 0.6 dB @ 1.85 GHz
  - 0.65 dB @ 2.6 GHz
  - 0.7 dB @ 3.6 GHz
- High IIP3 performance: +17.8 dBm @ 3.6 GHz
- Return loss > 17.5 dB @ 3.6 GHz
- Adjustable supply current and gain
- Flexible bias voltage: 3 to 5 V
- Adjustable supply current from 30 mA to 100 mA
- Temperature and process-stable active bias
- Miniature DFN (8-pin, 2 x 2 mm) package (MSL1 @ 260 °C per JEDEC J-STD-020)



Skyworks Green™ products are compliant with all applicable legislation and are halogen-free. For additional information, refer to *Skyworks Definition of Green™*, document number SQ04-0074.

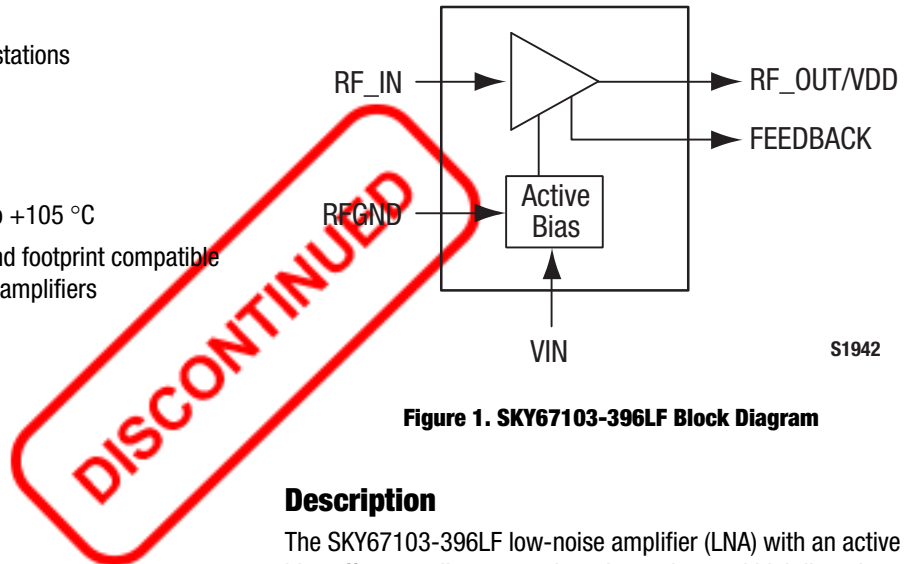


Figure 1. SKY67103-396LF Block Diagram

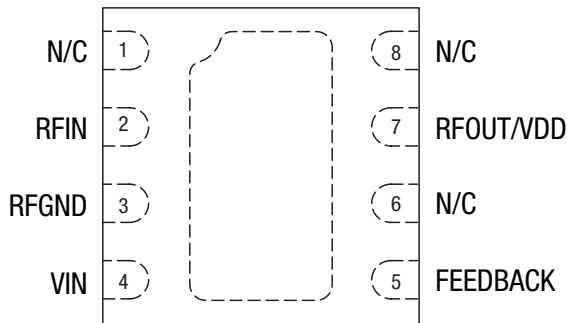
## Description

The SKY67103-396LF low-noise amplifier (LNA) with an active bias offers excellent return loss, low noise, and high linearity performance.

The internal active bias circuitry provides stable performance over temperature and process variation. The device offers the ability to externally adjust supply current and gain. Supply voltage is applied to the RFOUT/VDD pin through an RF choke inductor. Pin 4 (VIN) should be connected to RFOUT/VDD through an external resistor to control the supply current. The RFIN and RFOUT/VDD pins should be DC blocked to ensure proper operation. Pin 5 (FEEDBACK) is connected through an RC network to externally adjust the gain of the device without affecting the noise figure (NF) of the LNA.

The SKY67103-396LF operates in the frequency range of 0.5 to 4.0 GHz with appropriate tuning. The SKY67103-396LF is an improved higher frequency version of the SKY67102-396LF. The SKY67103-396LF is pin-compatible with the SKY67100-396LF and SKY67101-396LF series of low-noise devices.

The LNA is available in a compact, 2 x 2 mm, 8-pin Dual Flat No-Lead (DFN) package. A functional block diagram is shown in Figure 1. The pin configuration and package are shown in Figure 2. Signal pin assignments and functional pin descriptions are provided in Table 1.



S1943

**Figure 2. SKY67103-396LF Pinout – 8-Pin DFN (Top View)**

**Table 1. SKY67103-396LF Signal Descriptions**

Pin	Name	Description	Pin	Name	Description
1	N/C	No connection. May be connected to ground with no change in performance.	5	FEEDBACK	LNA external gain control. Connect to RFOUT using a series RC network.
2	RFIN	RF input. DC blocking capacitor required.	6	N/C	No connection. May be connected to ground with no change in performance.
3	RFGND	RF ground. Connect to ground through a capacitor.	7	RFOUT/VDD	RF output. Apply VDD through RF choke inductor. DC blocking capacitor required.
4	VIN	LNA supply current. Connect through series resistor to VDD.	8	N/C	No connection. May be connected to ground with no change in performance.

### Electrical and Mechanical Specifications

The absolute maximum ratings of the SKY67103-396LF are provided in Table 2. Thermal performance data are provided in Table 3.

Typical performance characteristics of the SKY67103-396LF for broadband operation are illustrated in Figures 3 through 13.

Electrical specifications for broadband operation are provided in Table 4.

Electrical specifications for narrowband operation are provided in Tables 5, 6, and 7. Table 8 provides data for noise parameters versus frequency.

**Table 2. SKY67103-396LF Absolute Maximum Ratings (Note 1)**

Parameter	Symbol	Minimum	Maximum	Units
Supply voltage	V <sub>dd</sub>		5.5	V
Quiescent supply current	I <sub>dq</sub>		120	mA
RF input power	P <sub>in</sub>		+21	dBm
Storage temperature	T <sub>stg</sub>	-40	+150	°C
Operating temperature	T <sub>A</sub>	-40	+105	°C
Electrostatic discharge:	ESD			
Charged Device Model (CDM), Class 4			1000	V
Human Body Model (HBM), Class 1A			250	V
Machine Model (MM), Class A			30	V

**Note 1:** Performance is guaranteed only under the conditions listed in this table.

**CAUTION:** Although this device is designed to be as robust as possible, electrostatic discharge (ESD) can damage this device. This device must be protected at all times from ESD. Static charges may easily produce potentials of several kilovolts on the human body or equipment, which can discharge without detection. Industry-standard ESD precautions should be used at all times.

**Table 3. SKY67103-396LF: Thermal Performance Data (Note 1)**

**(V<sub>DD</sub> = 5 V, T<sub>A</sub> = +25 °C, P<sub>IN</sub> = -25 dBm, Characteristic Impedance [Z<sub>0</sub>] = 50 Ω, Unless Otherwise Noted)**

Parameter	Symbol	Test Condition	Min	Typical	Max	Units
Thermal resistance	Θ <sub>jc</sub>			45		°C/W
Channel temperature @ +85 °C reference (package heat slug)		V <sub>DD</sub> = 5 V, I <sub>DD</sub> = 70 mA, no RF applied, dissipated power = 0.35 W		101		°C

**Note 1:** Performance is guaranteed only under the conditions listed in this table.

**Table 4. SKY67103-396LF Electrical Specifications for Operation at 3.6 GHz (Note 1)**  
**(V<sub>DD</sub> = 5.0 V, I<sub>DD</sub> = 78 mA, T<sub>A</sub> = +25 °C, P<sub>IN</sub> = -20 dBm, Characteristic Impedance [Z<sub>0</sub>] = 50 Ω, Unless Otherwise Noted)**

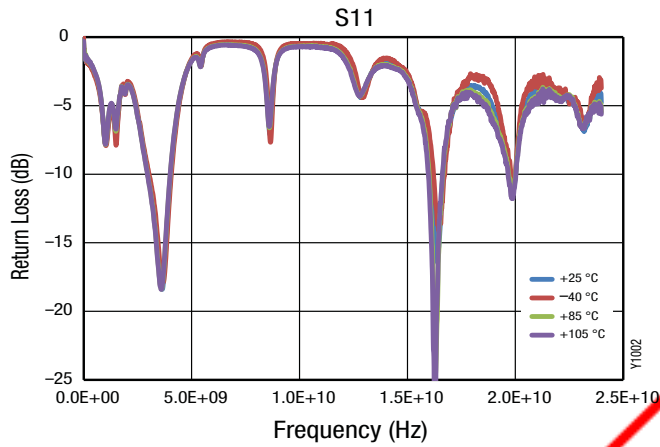
Parameter	Symbol	Test Condition	Min	Typical	Max	Units
<b>RF Specifications</b>						
Noise figure (Note 2)	NF	@ 3.4 GHz @ 3.6 GHz @ 3.8 GHz		0.65 0.70 0.76	0.85 0.90 0.96	dB dB dB
Small signal gain	IS21I	@ 3.4 GHz @ 3.6 GHz @ 3.8 GHz	15.3 15.0 14.6	16.8 16.5 16.1		dB dB dB
Input return loss	IS11I	@ 3.4 GHz @ 3.6 GHz @ 3.8 GHz		14.5 17.5 16.0		dB dB dB
Output return loss	IS22I	@ 3.4 GHz @ 3.6 GHz @ 3.8 GHz		18 17 17		dB dB dB
Reverse isolation	IS12I	@ 3.4 GHz @ 3.6 GHz @ 3.8 GHz		27.0 26.4 27.0		dB dB dB
3 <sup>rd</sup> Order input intercept point	IIP3	@ 3.6 GHz, Δf = 1 MHz, P <sub>IN</sub> = -20 dBm/tone		+17.8		dBm
3 <sup>rd</sup> Order output intercept point	OIP3	@ 3.6 GHz, Δf = 1 MHz, P <sub>IN</sub> = -20 dBm/tone		+34.3		dBm
1 dB input compression point	IP1dB	@ 3.6 GHz		+1.9		dBm
1 dB output compression point	OP1dB	@ 3.6 GHz		+17.4		dBm
Stability	μ1, μ2	Up to 18 GHz, -40 °C to +105 °C		>1		-
<b>DC Specifications</b>						
Supply voltage	V <sub>DD</sub>			5.0		V
Supply current	I <sub>DD</sub>	Set with external resistor		78		mA

**Note 1:** Performance is guaranteed only under the conditions listed in this table.

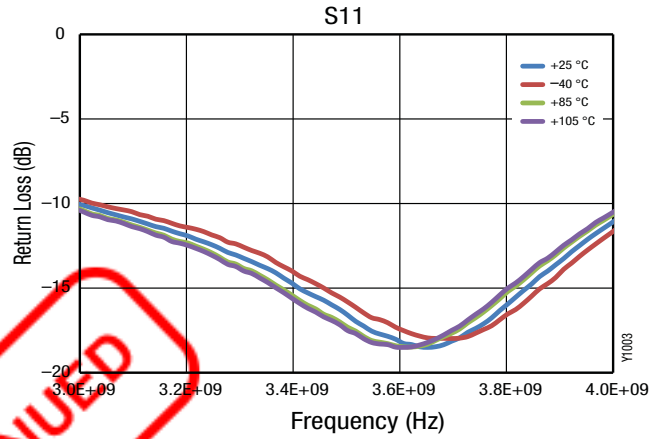
**Note 2:** Loss from the input SMA connector and Evaluation Board up to component C1 has been de-embedded from the NF measurement by 0.05 dB.

**Typical Performance Characteristics**

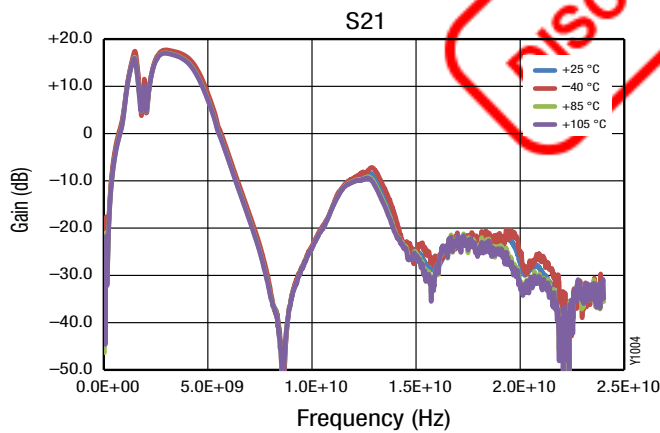
(V<sub>DD</sub> = 77 mA, P<sub>IN</sub> = -20 dBm, Characteristic Impedance [Z<sub>0</sub>] = 50 Ω, Unless Otherwise Noted)



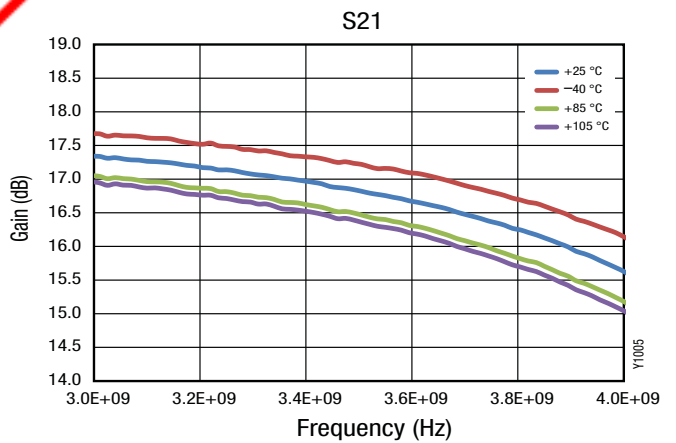
**Figure 3. Broadband Input Return Loss vs Frequency and Temperature**



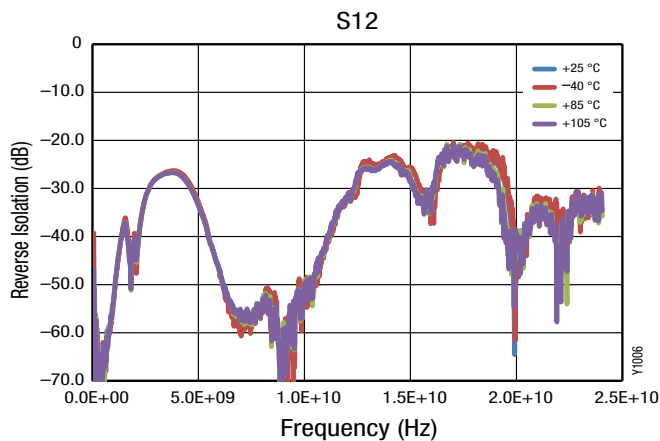
**Figure 4. Narrowband Input Return Loss vs Frequency and Temperature**



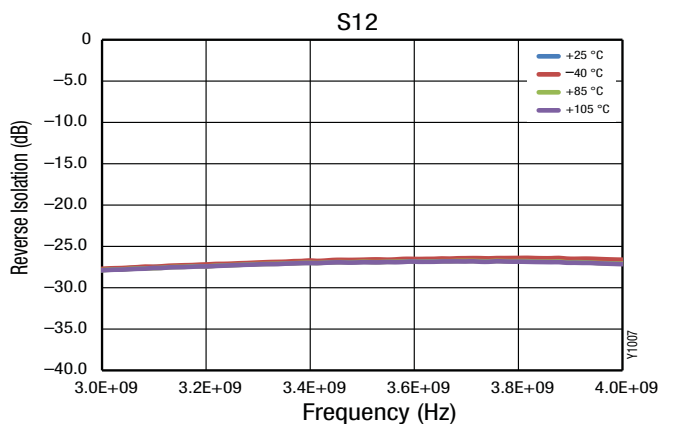
**Figure 5. Broadband Gain vs Frequency and Temperature**



**Figure 6. Narrowband Gain vs Frequency and Temperature**



**Figure 7. Broadband Reverse Isolation vs Frequency and Temperature**



**Figure 8. Narrowband Reverse Isolation vs Frequency and Temperature**

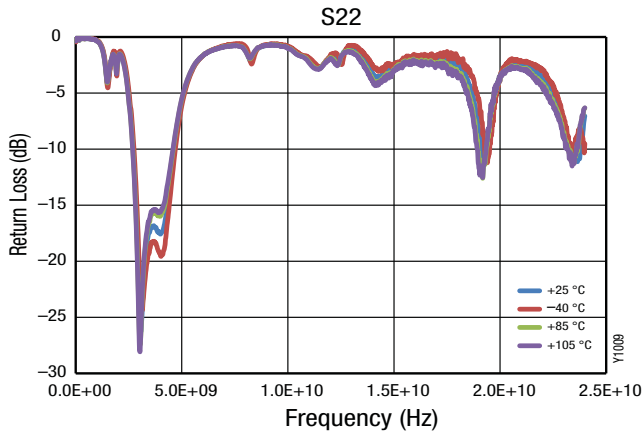


Figure 9. Broadband Output Return Loss vs Frequency and Temperature

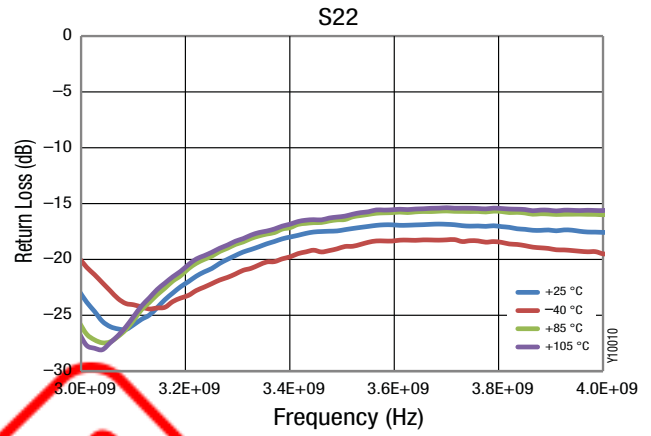


Figure 10. Narrowband Output Return Loss vs Frequency and Temperature

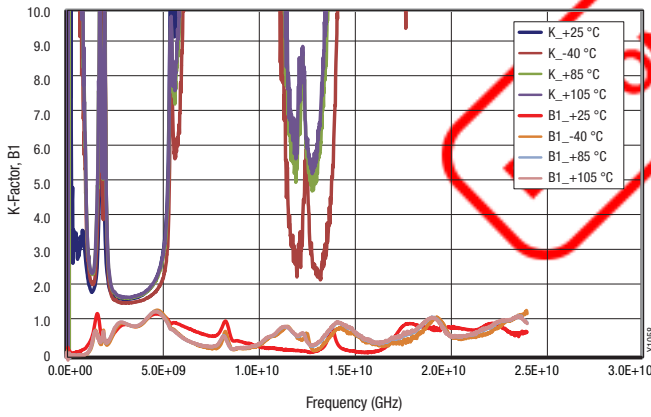


Figure 11. Stability Factor K, B1 vs Frequency and Temperature

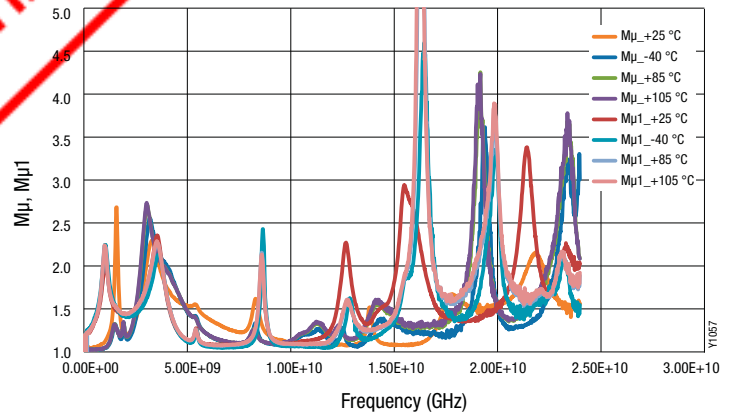


Figure 12. Stability Factor  $M\mu$ ,  $M\mu_1$  vs Frequency and Temperature

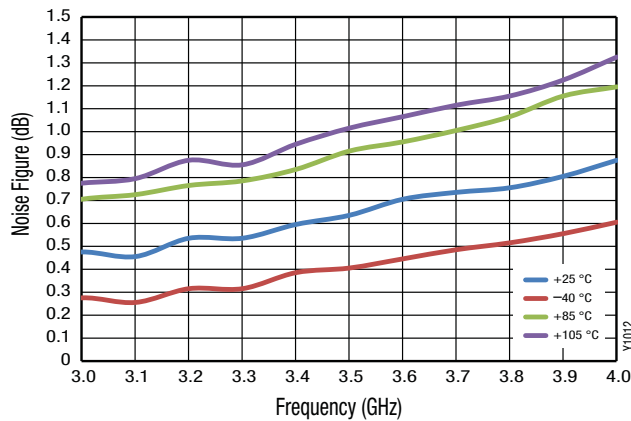


Figure 13. Noise Figure vs Frequency and Temperature

**Table 5. SKY67103-396LF Electrical Specifications for Operation at 850 MHz (Note 1)**  
**(V<sub>DD</sub> = 5.0 V, I<sub>DD</sub> = 78 mA, T<sub>A</sub> = +25 °C, P<sub>IN</sub> = -20 dBm, Characteristic Impedance [Z<sub>0</sub>] = 50 Ω, Unless Otherwise Noted)**

Parameter	Symbol	Test Condition	Min	Typical	Max	Units
Noise figure (Note 2)	NF	@ 850 MHz		0.50		dB
Small signal gain	IS21I	@ 850 MHz		25.0		dB
Input return loss	IS11I	@ 850 MHz		16.0		dB
Output return loss	IS22I	@ 850 MHz		15.0		dB
Reverse isolation	IS12I	@ 850 MHz		32.0		dB
Input third order intercept point	IIP3	$\Delta F=1$ MHz, P <sub>IN</sub> =-20 dBm/Tone 850 MHz		+7.5		dBm
Output third order intercept point	OIP3	$\Delta F=1$ MHz, P <sub>IN</sub> =-20 dBm/Tone 850 MHz		+34.5		dBm
Input 1 dB compression point	IP1dB	@ 850 MHz		-5.0		dBm
Output 1 dB compression point	OP1dB	@ 850 MHz		+21.0		dBm
Stability	$\mu_1, \mu_2, K, B$			>1		
<b>DC Specifications</b>						
Supply voltage	VDD			5.0		V
Quiescent supply current	IDD			76.0		mA

**Note 1:** Performance is guaranteed only under the conditions listed in this table.

**Note 2:** No correction for evaluation board and connector has been taken in the measurement.

**Table 6. SKY67103-396LF Electrical Specifications for Operation at 1.85 GHz (Note 1)**  
**(V<sub>DD</sub> = 5.0 V, I<sub>DD</sub> = 78 mA, T<sub>A</sub> = +25 °C, P<sub>IN</sub> = -20 dBm, Characteristic Impedance [Z<sub>0</sub>] = 50 Ω, Unless Otherwise Noted)**

Parameter	Symbol	Test Condition	Min	Typical	Max	Units
Noise figure (Note 2)	NF	@ 1.85 GHz		0.60		dB
Small signal gain	IS21I	@ 1.85 GHz		20.0		dB
Input return loss	IS11I	@ 1.85 GHz		16.0		dB
Output return loss	IS22I	@ 1.85 GHz		15.0		dB
Reverse isolation	IS12I	@ 1.85 GHz		28.0		dB
Input third order intercept point	IIP3	ΔF=1 MHz, P <sub>IN</sub> =-20 dBm/Tone 1850 MHz		+15.5		dBm
Output third order intercept point	OIP3	ΔF=1 MHz, P <sub>IN</sub> =-20 dBm/Tone 1850 MHz		+35.5		dBm
Input 1 dB compression point	IP1dB	@ 1.85 GHz		+1.0		dBm
Output 1 dB compression point	OP1dB	@ 1.85 GHz		+20.0		dBm
Stability	μ1, μ2, K, B			>1		-
<b>DC Specifications</b>						
Supply voltage	VDD			5.0		V
Quiescent supply current	IDD			76.0		mA

**Note 1:** Performance is guaranteed only under the conditions listed in this table.

**Note 2:** No correction for evaluation board and connector has been taken in the measurement.



**Table 7. SKY67103-396LF Electrical Specifications for Operation at 2.6 GHz (Note 1)**  
**(V<sub>DD</sub> = 5.0 V, I<sub>DD</sub> = 78 mA, T<sub>A</sub> = +25 °C, P<sub>IN</sub> = -20 dBm, Characteristic Impedance [Z<sub>0</sub>] = 50 Ω, Unless Otherwise Noted)**

Parameter	Symbol	Test Condition	Min	Typical	Max	Units
Noise figure (Note 2)	NF	@ 2.6 GHz		0.65		dB
Small signal gain	IS21I	@ 2.5 GHz		18.4		dB
		@ 2.6 GHz		18.2		dB
		@ 2.7 GHz		17.9		dB
Input return loss	IS11I	@ 2.5 GHz		14.2		dB
		@ 2.6 GHz		16.4		dB
		@ 2.7 GHz		18.7		dB
Output return loss	IS22I	@ 2.5 GHz		24.9		dB
		@ 2.6 GHz		19.6		dB
		@ 2.7 GHz		17.5		dB
Reverse isolation	IS12I	@ 2.5 GHz		28.2		dB
		@ 2.6 GHz		27.9		dB
		@ 2.7 GHz		27.7		dB
Input third order intercept point	IIP3	ΔF=1 MHz, P <sub>IN</sub> =-20 dBm/Tone 2600 MHz		+17.5		dBm
Output third order intercept point	OIP3	ΔF=1 MHz, P <sub>IN</sub> =-20 dBm/Tone 2600 MHz		+35.8		dBm
Input 1 dB compression point	IP1dB	@ 2600 MHz		+1.6		dBm
Output 1 dB compression point	OP1dB	@ 2600 MHz		+18.9		dBm
Stability	μ1, μ2, K, B			>1		
<b>DC Specifications</b>						
Supply voltage	VDD			5		V
Quiescent supply current	IDD			76		mA

**Note 1:** Performance is guaranteed only under the conditions listed in this table.

**Note 2:** No correction for evaluation board and connector has been taken in the measurement.

**Table 8. Noise Parameters vs Frequency (@ +25 °C, 5 V, 78 mA) (1 of 3)**

Frequency (MHz)	FMIN (dB)	Gamma opt (Mag)	Gamma opt (Phase)	Noise Resistance (RN) (Ω)	Associated Gain (dB)	Maximum Gain (GMAX) (dB)
400	0.33	0.40	7.69	0.06	29.58	31.69
450	0.31	0.37	13.49	0.06	29.19	31.12
500	0.30	0.35	19.08	0.05	28.81	30.58
550	0.29	0.33	24.47	0.05	28.44	30.05
600	0.28	0.31	29.66	0.05	28.07	29.55
650	0.27	0.29	34.66	0.05	27.72	29.06
700	0.26	0.27	39.48	0.05	27.38	28.60
750	0.25	0.26	44.13	0.04	27.04	28.16
800	0.25	0.25	48.60	0.04	26.72	27.73
850	0.24	0.23	52.92	0.04	26.40	27.32
900	0.24	0.22	57.08	0.04	26.09	26.93
950	0.23	0.21	61.09	0.04	25.79	26.55
1000	0.23	0.20	64.96	0.04	25.50	26.19
1050	0.23	0.20	68.69	0.04	25.22	25.84
1100	0.23	0.19	72.29	0.03	24.94	25.51
1150	0.23	0.19	75.77	0.03	24.67	25.19
1200	0.23	0.18	79.12	0.03	24.41	24.89
1250	0.23	0.18	82.37	0.03	24.16	24.60
1300	0.24	0.18	85.51	0.03	23.91	24.32
1350	0.24	0.17	88.54	0.03	23.67	24.05
1400	0.24	0.17	91.48	0.03	23.43	23.79
1450	0.25	0.17	94.33	0.03	23.21	23.55
1500	0.25	0.17	97.09	0.03	22.98	23.31
1550	0.25	0.17	99.76	0.03	22.77	23.08
1600	0.26	0.18	102.36	0.03	22.56	22.87
1650	0.27	0.18	104.89	0.03	22.35	22.66
1700	0.27	0.18	107.35	0.03	22.15	22.46
1750	0.28	0.19	109.74	0.03	21.96	22.27
1800	0.28	0.19	112.08	0.03	21.77	22.08
1850	0.29	0.19	114.36	0.03	21.59	21.90
1900	0.30	0.20	116.58	0.03	21.41	21.73
1950	0.31	0.20	118.76	0.03	21.23	21.57
2000	0.31	0.21	120.89	0.03	21.06	21.41
2050	0.32	0.22	122.99	0.03	20.90	21.26
2100	0.33	0.22	125.04	0.03	20.74	21.11
2150	0.34	0.23	127.06	0.03	20.58	20.97
2200	0.35	0.24	129.05	0.03	20.42	20.83
2250	0.36	0.24	131.00	0.03	20.27	20.69



**Table 8. Noise Parameters vs Frequency (@ +25 °C, 5 V, 78 mA) (2 of 3)**

Frequency (MHz)	F <sub>MIN</sub> (dB)	Gamma opt (Mag)	Gamma opt (Phase)	Noise Resistance (R <sub>N</sub> ) (Ω)	Associated Gain (dB)	Maximum Gain (G <sub>MAX</sub> ) (dB)
2300	0.37	0.25	132.94	0.03	20.13	20.56
2350	0.37	0.26	134.85	0.03	19.99	20.44
2400	0.38	0.26	136.74	0.03	19.85	20.31
2450	0.39	0.27	138.61	0.03	19.71	20.19
2500	0.40	0.28	140.46	0.03	19.58	20.07
2550	0.41	0.29	142.31	0.03	19.45	19.96
2600	0.42	0.29	144.14	0.03	19.32	19.85
2650	0.43	0.30	145.96	0.03	19.19	19.74
2700	0.44	0.31	147.77	0.03	19.07	19.63
2750	0.45	0.32	149.57	0.03	18.95	19.52
2800	0.45	0.32	151.37	0.03	18.84	19.42
2850	0.46	0.33	153.17	0.03	18.72	19.32
2900	0.47	0.34	154.97	0.03	18.61	19.21
2950	0.48	0.34	156.76	0.03	18.50	19.11
3000	0.49	0.35	158.55	0.03	18.39	19.02
3050	0.50	0.36	160.35	0.03	18.29	18.92
3100	0.51	0.36	162.14	0.03	18.18	18.82
3150	0.51	0.37	163.94	0.04	18.08	18.72
3200	0.52	0.38	165.74	0.04	17.98	18.63
3250	0.53	0.38	167.54	0.04	17.89	18.53
3300	0.54	0.39	169.35	0.04	17.79	18.44
3350	0.55	0.39	171.16	0.04	17.69	18.34
3400	0.55	0.40	172.97	0.04	17.60	18.25
3450	0.56	0.41	174.78	0.04	17.51	18.15
3500	0.57	0.41	176.59	0.04	17.42	18.06
3550	0.58	0.42	178.41	0.04	17.33	17.97
3600	0.58	0.42	-179.77	0.04	17.24	17.87
3650	0.59	0.43	-177.96	0.04	17.16	17.78
3700	0.60	0.43	-176.14	0.04	17.07	17.69
3750	0.60	0.43	-174.33	0.04	16.99	17.60
3800	0.61	0.44	-172.52	0.04	16.91	17.51
3850	0.62	0.44	-170.71	0.04	16.83	17.42
3900	0.62	0.45	-168.91	0.04	16.75	17.33
3950	0.63	0.45	-167.11	0.04	16.67	17.25
4000	0.64	0.45	-165.33	0.04	16.59	17.16
4050	0.64	0.46	-163.55	0.04	16.52	17.07
4100	0.65	0.46	-161.79	0.04	16.44	16.99
4150	0.66	0.46	-160.05	0.04	16.37	16.91

Table 8. Noise Parameters vs Frequency (@ +25 °C, 5 V, 78 mA) (3 of 3)

Frequency (MHz)	FMIN (dB)	Gamma opt (Mag)	Gamma opt (Phase)	Noise Resistance (RN) (Ω)	Associated Gain (dB)	Maximum Gain (GMAX) (dB)
4200	0.66	0.46	-158.32	0.04	16.30	16.83
4250	0.67	0.47	-156.61	0.04	16.23	16.75
4300	0.68	0.47	-154.92	0.04	16.15	16.67
4350	0.68	0.47	-153.26	0.04	16.09	16.60
4400	0.69	0.47	-151.62	0.04	16.02	16.52
4450	0.70	0.47	-150.02	0.04	15.95	16.45
4500	0.70	0.48	-148.45	0.04	15.89	16.39
4550	0.71	0.48	-146.91	0.04	15.82	16.32
4600	0.72	0.48	-145.42	0.04	15.76	16.26
4650	0.72	0.48	-143.96	0.04	15.70	16.20
4700	0.73	0.48	-142.56	0.04	15.64	16.15
4750	0.74	0.49	-141.21	0.04	15.58	16.10
4800	0.74	0.49	-139.91	0.05	15.52	16.06
4850	0.75	0.49	-138.66	0.05	15.46	16.02
4900	0.76	0.49	-137.48	0.05	15.41	15.98
4950	0.77	0.49	-136.37	0.05	15.35	15.95
5000	0.78	0.50	-135.33	0.05	15.30	15.93
5050	0.79	0.50	-134.36	0.05	15.25	15.91
5100	0.80	0.50	-133.48	0.05	15.20	15.90
5150	0.81	0.51	-132.68	0.06	15.15	15.90
5200	0.82	0.51	-131.97	0.06	15.11	15.90
5250	0.83	0.51	-131.35	0.06	15.06	15.92
5300	0.84	0.52	-130.83	0.06	15.02	15.94
5350	0.85	0.52	-130.42	0.06	14.98	15.97
5400	0.86	0.53	-130.12	0.07	14.94	16.00
5450	0.88	0.53	-129.94	0.07	14.91	16.05
5500	0.89	0.54	-129.88	0.07	14.87	16.11
5550	0.90	0.54	-129.95	0.07	14.84	16.18
5600	0.92	0.55	-130.15	0.08	14.81	16.25
5650	0.93	0.56	-130.49	0.08	14.79	16.35
5700	0.95	0.56	-130.97	0.08	14.76	16.45
5750	0.97	0.57	-131.61	0.09	14.74	16.56
5800	0.99	0.58	-132.41	0.09	14.72	16.69
5850	1.01	0.59	-133.37	0.10	14.71	16.83
5900	1.03	0.60	-134.51	0.10	14.70	16.99
5950	1.05	0.61	-135.82	0.11	14.69	17.16
6000	1.07	0.62	-137.33	0.11	14.68	17.35



### Evaluation Board Description

The SKY67103-396LF Evaluation Board is used to test the performance of the SKY67103-396LF LNA. An assembly drawing for the Evaluation Board is shown in Figure 14. An Evaluation Board schematic diagram is provided in Figure 15. Table 9 provides the Bill of Materials (BOM) list for Evaluation Board components at 3600 MHz.

The test board uses a 10 mil Rogers 4350B substrate on a 50 mil FR4 supporting substrate. The Rogers 4350B material was selected for the RF circuit because of its low dielectric constant ( $\epsilon_r$ ) and low  $\epsilon_r$  variation over temperature for the best possible noise performance.

### Package Dimensions

The PCB layout footprint for the SKY67103-396LF is provided in Figure 16. Typical case markings are shown in Figure 17. Package dimensions for the 8-pin DFN are shown in Figure 18, and tape and reel dimensions are provided in Figure 19.

### Package and Handling Information

Instructions on the shipping container label regarding exposure to moisture after the container seal is broken must be followed. Otherwise, problems related to moisture absorption may occur when the part is subjected to high temperature during solder assembly.

The SKY67103-396LF is rated to Moisture Sensitivity Level 1 (MSL1) at 260 °C. It can be used for lead or lead-free soldering. For additional information, refer to the Skyworks Application Note, *Solder Reflow Information*, document number 200164.

Care must be taken when attaching this product, whether it is done manually or in a production solder reflow environment. Production quantities of this product are shipped in a standard tape and reel format.

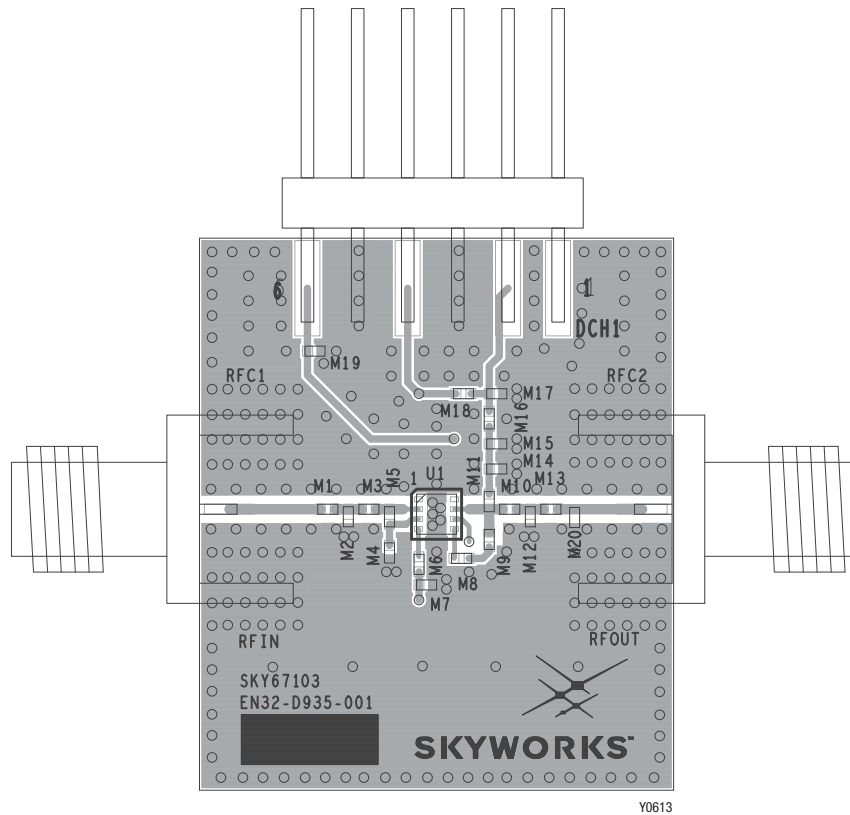


Figure 14. SKY67103-396LF Evaluation Board Assembly Diagram

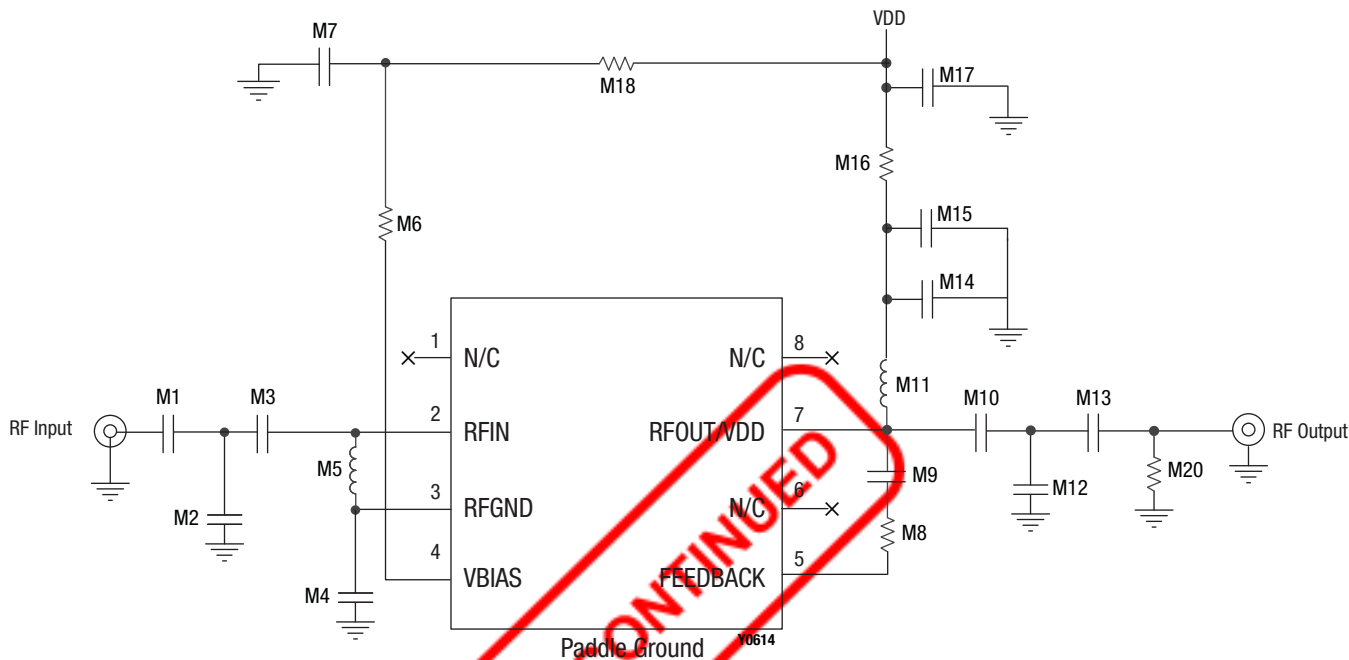


Figure 15. SKY67103-396LF Evaluation Board Schematic

Table 9. SKY67103-396LF Evaluation Board Bill of Materials (3 GHz to 4 GHz)

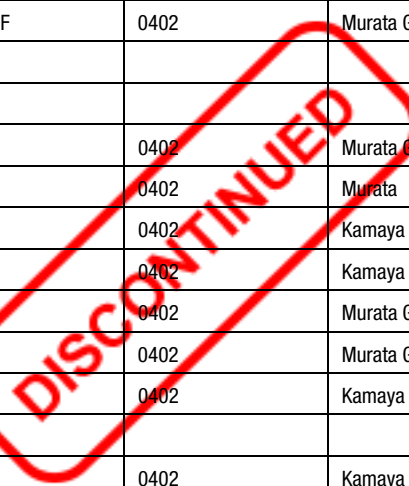
Component	Description	Value	Size	Manufacturer	Mfr Part Number
M1	Capacitor	15 pF	0402	Murata GJM	GJM1555C1H150JB01
M2	Capacitor	1 pF	0402	Murata GJM	GJM1555C1H1R0CB01
M3	Resistor	0 Ω	0402	Kamaya RMC 1/16S	RMC1/16SJPTH
M4		DNP			
M5	Inductor	15 nH	0402	Coilcraft HP	0402HP-15N0XJL
M6	Resistor	10.2k	0402	Kamaya RMC 1/16S	RMC1/16SK1022FTH
M7	Capacitor	1000 pF	0402	Murata GRM	GRM155R71H102KA01
M8		DNP			
M9		DNP			
M10	Inductor	1 nH	0402	Coilcraft HP	0402HP-1N0XJL
M11	Inductor	1 nH	0402	Coilcraft HP	0402HP-1N0XJL
M12		DNP			
M13	Capacitor	1.1 pF	0402	Murata GJM	GJM1555C1H1R1CB01
M14	Capacitor	10 pF	0402	Murata GJM	GJM1555C1H100JB01
M15	Capacitor	1000 pF	0402	Murata GRM	GRM155R71H102KA01
M16	Resistor	0 Ohm	0402	Kamaya RMC 1/16S	RMC1/16SJPTH
M17		DNP			
M18	Resistor	0 Ω	0402	Kamaya RMC 1/16S	RMC1/16SJPTH
M19		DNP			
M20	Resistor	5.1k	0402	Kamaya RMC 1/16S	RMC1/16SK511FTH

**Table 10. SKY67103-396LF Evaluation Board Bill of Materials (850 MHz)**

Component	Description	Value	Size	Manufacturer	Mfr Part Number
M1	Inductor	2.2 nH	0402	Coilcraft	0402HP-2N2XJL
M2	DNI				
M3	Capacitor	20 pF	0402	Murata GJM	GJM1555C1H200JB01
M4	Capacitor	68 pF	0402	Murata GRM	GRM1555C1H680JZ01
M5	Inductor	15 nH	0402	Coilcraft HP	0402HP-15N0XJL
M6	Resistor	10.2k	0402	Kamaya RMC 1/16S	RMC1/16SK1022FTH
M7	Capacitor	1000 pF	0402	Murata GRM	GRM155R71H102KA01
M8		DNP			
M9		DNP			
M10	Capacitor	100 pF	0402	Murata GJM	GRM1555C1H101JZ01
M11	Inductor	8.2 nH	0402	Murata	LQG15HS8N2J02
M12	Capacitor	1.8 pF	0402	Murata GJM	GRM1555C1H1R8CB01
M14	Capacitor	100 pF	0402	Murata GJM	GRM1555C1H101JZ01
M14	Capacitor	100 pF	0402	Murata GJM	GRM1555C1H101JZ01
M15	Capacitor	10000 pF	0402	Murata GRM	GRM155R71H103KA01
M16	Resistor	0 $\Omega$	0402	Kamaya RMC 1/16S	RMC1/16SJPTH
M17		DNP			
M18	Resistor	0 $\Omega$	0402	Kamaya RMC 1/16S	RMC1/16SJPTH
M19		DNP			
M20	Resistor	5.1k	0402	Kamaya RMC 1/16S	RMC1/16SK511FTH

**Table 11. SKY67103-396LF Evaluation Board Bill of Materials (1.85 GHz)**

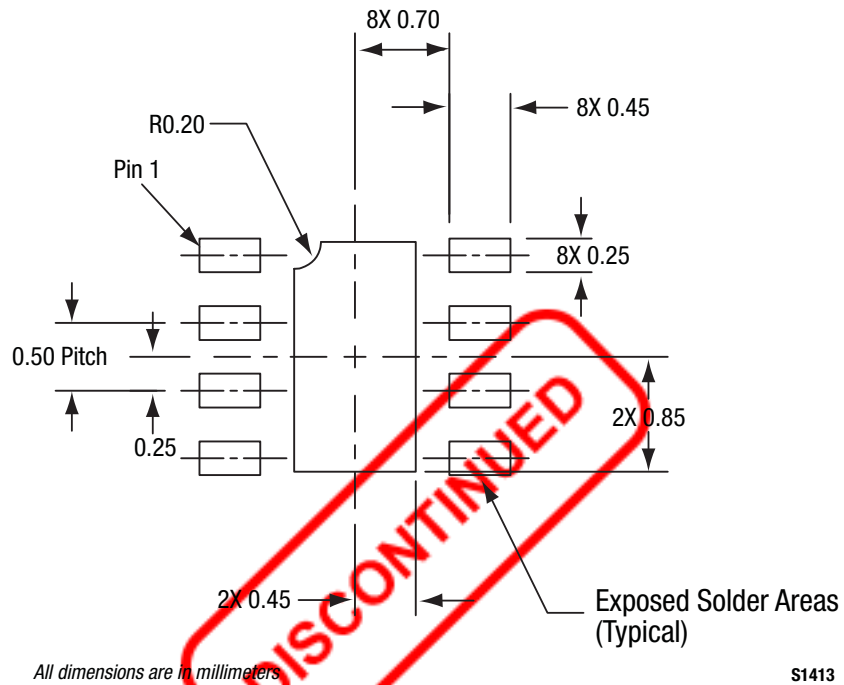
Component	Description	Value	Size	Manufacturer	Mfr Part Number
M1	Capacitor	20 pF	0402	Murata GJM	GJM1555C1H200JB01
M2	Capacitor	1 pF	0402	Murata GJM	GJM1555C1H1R0CB01
M3	Inductor	2 nH	0402	Coilcraft HP	0402HP-2N0XJL
M4	Capacitor	8.2 pF	0402	Murata GRM	GJM1555C1H8R2DB01
M5	Inductor	10 nH	0402	Coilcraft HP	0402HP-10N0XJL
M6	Resistor	10.2 K	0402	Kamaya RMC 1/16S	RMC1/16SK1022FTH
M7	Capacitor	10000 pF	0402	Murata GRM	GRM155R71H103KA01
M8		DNP			
M9		DNP			
M10	Capacitor	3.6 pF	0402	Murata GJM	GRM1555C1H3R6CB01
M11	Inductor	3.6 nH	0402	Murata	LQG15HS3N6S02
M12	Resistor	2.0 K	0402	Kamaya RMC 1/16S	RMC1/16S-202JTH
M13	Resistor	0 Ω	0402	Kamaya RMC 1/16S	RMC1/16SJPTH
M14	Capacitor	22 pF	0402	Murata GRM	GRM1555C1H220JZ01
M15	Capacitor	1000 pF	0402	Murata GRM	GRM155R71H102KA01
M16	Resistor	0 Ω	0402	Kamaya RMC 1/16S	RMC1/16SJPTH
M17		DNP			
M18	Resistor	0 Ω	0402	Kamaya RMC 1/16S	RMC1/16SJPTH
M19		DNP			
M20	Resistor	5.1k	0402	Kamaya RMC 1/16S	RMC1/16SK511FTH



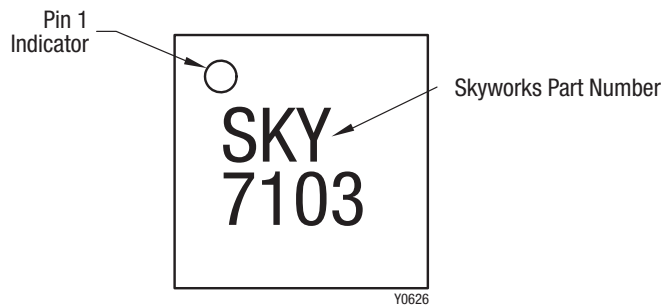


**Table 12. SKY67103-396LF Evaluation Board Bill of Materials (2.6 GHz)**

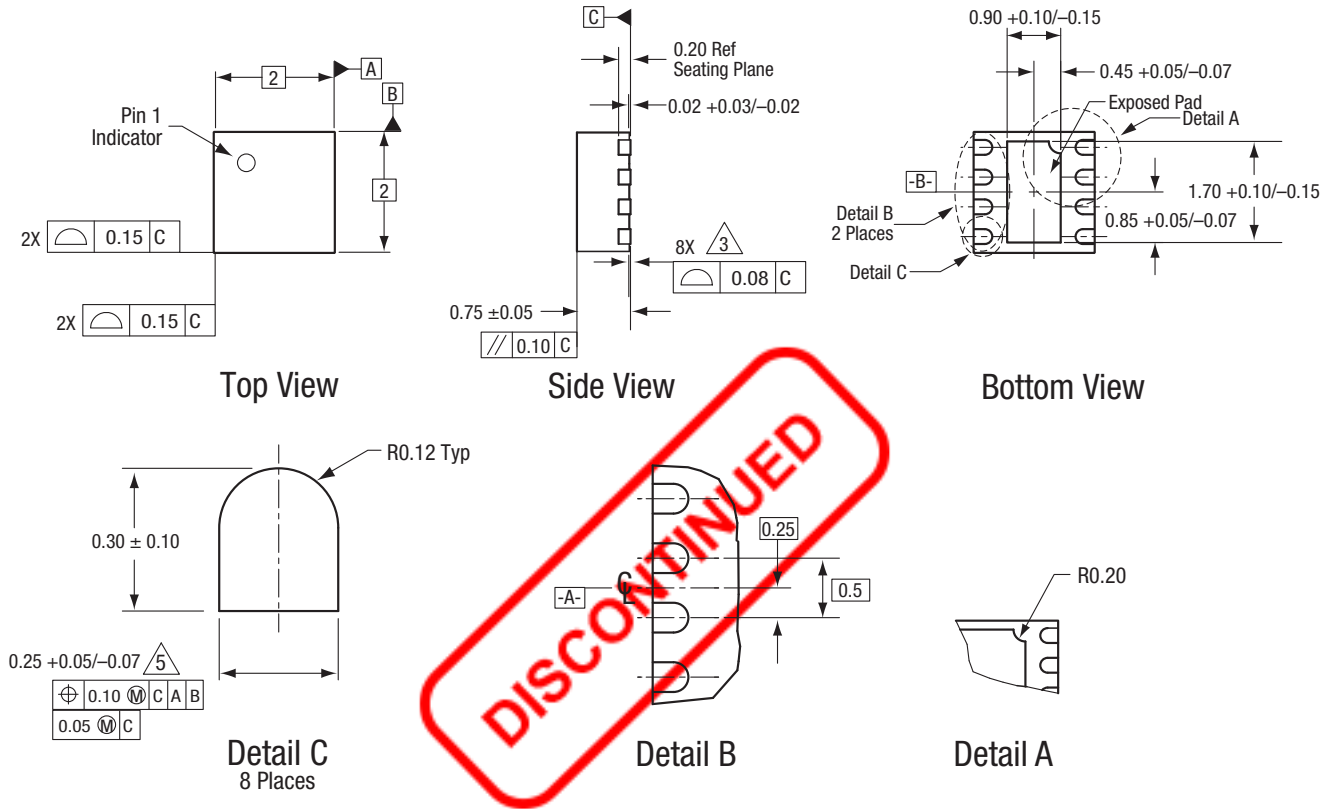
Component	Description	Value	Size	Manufacturer	Mfr Part Number
M1	Capacitor	20 pF	0402	Murata GJM	GJM1555C1H200JB01
M2	Capacitor	1 pF	0402	Murata GJM	GJM1555C1H1R0CB01
M3	Resistor	0 $\Omega$	0402	Kamaya RMC 1/16S	RMC1/16SJPTH
M4	Capacitor	56 pF	0402	Murata GRM	GRM1555C1H560JZ01
M5	Inductor	12 nH	0402	Coilcraft HP	0402HP-12N0XJL
M6	Resistor	10.2 K	0402	Kamaya RMC 1/16S	RMC1/16SK1022FTH
M7	Capacitor	10000 pF	0402	Murata GRM	GRM155R71H103KA01
M8		DNP			
M9		DNP			
M10	Capacitor	3.9 pF	0402	Murata GJM	GRM1555C1H3R9CZ01
M11	Inductor	2.7 nH	0402	Murata	LQG15HS2N7S02
M12	Resistor	2.0 K	0402	Kamaya RMC 1/16S	RMC1/16S-202JTH
M13	Resistor	0 $\Omega$	0402	Kamaya RMC 1/16S	RMC1/16SJPTH
M14	Capacitor	22 pF	0402	Murata GRM	GRM1555C1H220JZ01
M15	Capacitor	1000 pF	0402	Murata GRM	GRM155R71H102KA01
M16	Resistor	0 Ohm	0402	Kamaya RMC 1/16S	RMC1/16SJPTH
M17		DNP			
M18	Resistor	0 $\Omega$	0402	Kamaya RMC 1/16S	RMC1/16SJPTH
M19		DNP			
M20	Resistor	5.1k	0402	Kamaya RMC 1/16S	RMC1/16SK511FTH



**Figure 15. SKY67103-396LF PCB Layout Footprint (Top View)**



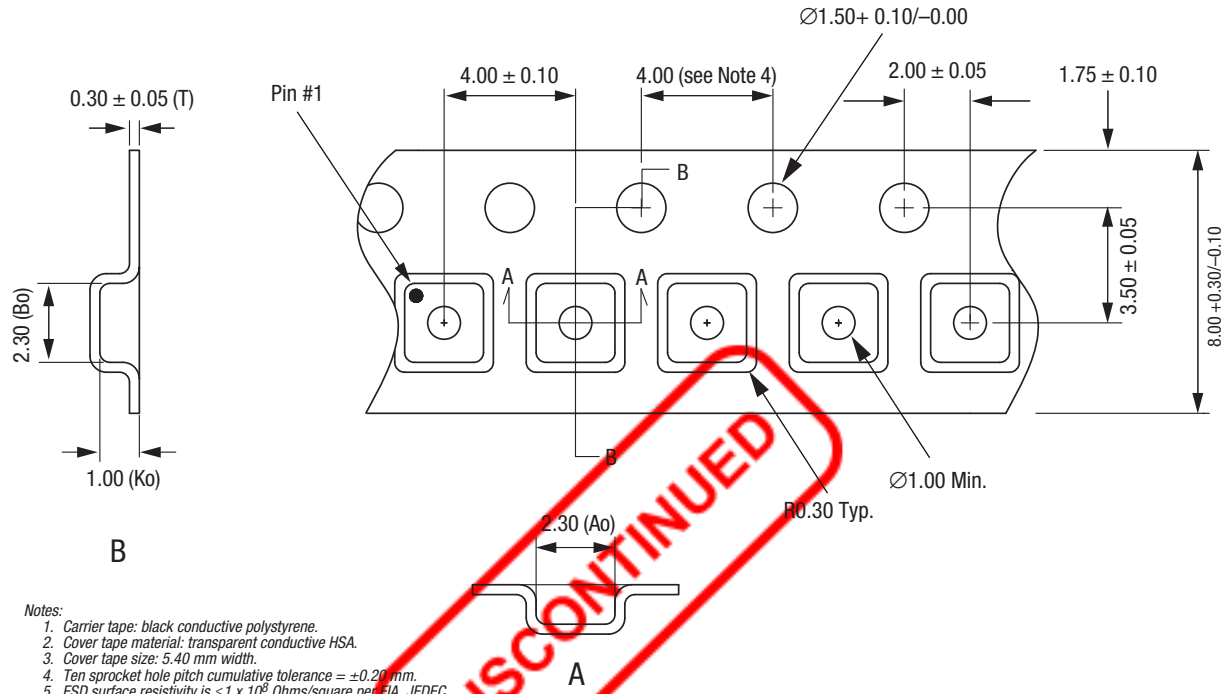
**Figure 16. Typical Case Markings (Top View)**



All measurements are in millimeters.  
 Dimensioning and tolerancing according to ASME Y14.5M-1994.  
 Coplanarity applies to the exposed heat sink slug as well as the terminals..  
 Plating requirement per source control drawing (SCD) 2504.  
 Dimension applies to metallized terminal and is measured between 0.15 mm and 0.30 mm from terminal tip.

S1945

Figure 17. SKY67103-396LF 8-Pin DFN Package Dimensions



- Notes:
1. Carrier tape: black conductive polystyrene.
  2. Cover tape material: transparent conductive HSA.
  3. Cover tape size: 5.40 mm width.
  4. Ten sprocket hole pitch cumulative tolerance = ±0.20 mm.
  5. ESD surface resistivity is  $\leq 1 \times 10^9$  Ohms/square per EIA, JEDEC tape and reel specification.
  6. Ao and Bo measurement point to be 0.30 mm from bottom pocket.
  7. All measurements are in millimeters.

S1601

Figure 18. SKY67103-396LF Tape and Reel Dimensions

## Ordering Information

Model Name	Manufacturing Part Number	Evaluation Board Part Number
SKY67103-396LF LNA	SKY67103-396LF	SKY67103-396LF-EVB



Copyright © 2014 Skyworks Solutions, Inc. All Rights Reserved.

Information in this document is provided in connection with Skyworks Solutions, Inc. (“Skyworks”) products or services. These materials, including the information contained herein, are provided by Skyworks as a service to its customers and may be used for informational purposes only by the customer. Skyworks assumes no responsibility for errors or omissions in these materials or the information contained herein. Skyworks may change its documentation, products, services, specifications or product descriptions at any time, without notice. Skyworks makes no commitment to update the materials or information and shall have no responsibility whatsoever for conflicts, incompatibilities, or other difficulties arising from any future changes.

No license, whether express, implied, by estoppel or otherwise, is granted to any intellectual property rights by this document. Skyworks assumes no liability for any materials, products or information provided hereunder, including the sale, distribution, reproduction or use of Skyworks products, information or materials, except as may be provided in Skyworks Terms and Conditions of Sale.

THE MATERIALS, PRODUCTS AND INFORMATION ARE PROVIDED “AS IS” WITHOUT WARRANTY OF ANY KIND, WHETHER EXPRESS, IMPLIED, STATUTORY, OR OTHERWISE, INCLUDING FITNESS FOR A PARTICULAR PURPOSE OR USE, MERCHANTABILITY, PERFORMANCE, QUALITY OR NON-INFRINGEMENT OF ANY INTELLECTUAL PROPERTY RIGHT; ALL SUCH WARRANTIES ARE HEREBY EXPRESSLY DISCLAIMED. SKYWORKS DOES NOT WARRANT THE ACCURACY OR COMPLETENESS OF THE INFORMATION, TEXT, GRAPHICS OR OTHER ITEMS CONTAINED WITHIN THESE MATERIALS. SKYWORKS SHALL NOT BE LIABLE FOR ANY DAMAGES, INCLUDING BUT NOT LIMITED TO ANY SPECIAL, INDIRECT, INCIDENTAL, STATUTORY, OR CONSEQUENTIAL DAMAGES, INCLUDING WITHOUT LIMITATION, LOST REVENUES OR LOST PROFITS THAT MAY RESULT FROM THE USE OF THE MATERIALS OR INFORMATION, WHETHER OR NOT THE RECIPIENT OF MATERIALS HAS BEEN ADVISED OF THE POSSIBILITY OF SUCH DAMAGE.

Skyworks products are not intended for use in medical, lifesaving or life-sustaining applications, or other equipment in which the failure of the Skyworks products could lead to personal injury, death, physical or environmental damage. Skyworks customers using or selling Skyworks products for use in such applications do so at their own risk and agree to fully indemnify Skyworks for any damages resulting from such improper use or sale.

Customers are responsible for their products and applications using Skyworks products, which may deviate from published specifications as a result of design defects, errors, or operation of products outside of published parameters or design specifications. Customers should include design and operating safeguards to minimize these and other risks. Skyworks assumes no liability for applications assistance, customer product design, or damage to any equipment resulting from the use of Skyworks products outside of stated published specifications or parameters.

Skyworks, the Skyworks symbol, and “Breakthrough Simplicity” are trademarks or registered trademarks of Skyworks Solutions, Inc., in the United States and other countries. Third-party brands and names are for identification purposes only, and are the property of their respective owners. Additional information, including relevant terms and conditions, posted at [www.skyworksinc.com](http://www.skyworksinc.com), are incorporated by reference.

## X-ON Electronics

Largest Supplier of Electrical and Electronic Components

*Click to view similar products for [RF Amplifier](#) category:*

*Click to view products by [Skyworks](#) manufacturer:*

Other Similar products are found below :

[A82-1](#) [BGA622H6820XTSA1](#) [BGA 728L7 E6327](#) [BGB719N7ESDE6327XTMA1](#) [HMC397-SX](#) [HMC405](#) [HMC561-SX](#) [HMC8120-SX](#)  
[HMC8121-SX](#) [HMC-ALH382-SX](#) [HMC-ALH476-SX](#) [SE2433T-R](#) [SMA3101-TL-E](#) [SMA39](#) [A66-1](#) [A66-3](#) [A67-1](#) [A81-2](#) [LX5535LQ](#)  
[LX5540LL](#) [MAAM02350](#) [HMC3653LP3BETR](#) [HMC549MS8GETR](#) [HMC-ALH435-SX](#) [SMA101](#) [SMA32](#) [SMA411](#) [SMA531](#)  
[SST12LP19E-QX6E](#) [WPM0510A](#) [HMC5929LS6TR](#) [HMC5879LS7TR](#) [HMC1126](#) [HMC1087F10](#) [HMC1086](#) [HMC1016](#) [SMA1212](#)  
[MAX2689EWS+T](#) [MAAMSS0041TR](#) [MAAM37000-A1G](#) [LTC6430AIUF-15#PBF](#) [SMA70-2](#) [SMA4011](#) [A231](#) [HMC-AUH232](#) [LX5511LQ](#)  
[LX5511LQ-TR](#) [HMC7441-SX](#) [HMC-ALH310](#) [XD1001-BD-000V](#)