

PRODUCT SUMMARY

SKY68000-31: LTE Dual-Band Front-End Module for IoT

Applications

- Cellular IoT modem devices targeting low-power wide area network (LPWAN):
 - 4G LTE technology capability
 - Dedicated LTE half-duplex operation (HD-FDD) for LTE-M/NB-IoT
 - Designed to meet 3GPP Rel-13 specifications (with compatible cellular transceiver)
- LTE dual-band modem products (low-band and mid-band):
 - Band 13
 - Band 4
- PAE optimized for Class 3 LTE output power (+23 dBm)

Features

- Cost-optimized front end for low-data-rate applications
- Low-loss post-PA transmit front end for enhanced transmitter efficiency (compared to LTE-FDD radio front ends)
- Dual-band PA supporting APT mode of operation or Vcc fixed supply (≥ 2.85 V)
- Integrated low-pass filters for harmonic rejection to comply with spurious emission requirements
- Integrated SP4T antenna Tx/Rx switch
- Integrated Rx SAW filters for out of band rejection for both Band 13 and Band 4
- Optimized to support LTE for 1 to 6 RB
- MIPI® RFFE control interface, 2.0 compliant
- Footprint-compatible with the SKY68001-31 and SKY68011-31
- Adaptive biasing scheme for maximum PA efficiencies
- Small, low-profile package (4 mm x 5 mm x 0.9 mm) (MSL3 @ 260 °C per JEDEC J-STD-020)
- Lead (Pb)-free and RoHS-compliant



Skyworks Green™ products are compliant with all applicable legislation and are halogen-free. For additional information, refer to *Skyworks Definition of Green™*, document number SQ04-0074.

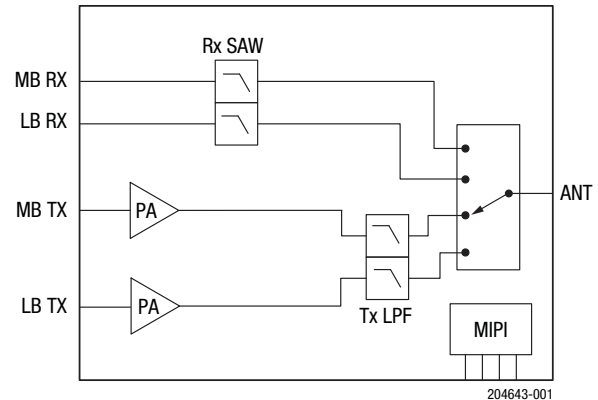

Figure 1. SKY68000-31 Functional Block Diagram

Description

The SKY68000-31 is a hybrid, dual-band multi-chip RF front-end (RFFE) module supporting cellular LTE-M/NB-IoT (half-duplex system) transceiver platforms. The module integrates the entire RF front end necessary for an LTE dual-band radio operating in Band 13 and Band 4 including Rx SAW filters, dual-band PA with bias controller, Tx low-pass harmonic filter, antenna switch, and MIPI RFFE controller.

Tx Section

The PA load-line is optimized for high efficiency while simultaneously meeting 3GPP ACLR and emissions mask specifications with LTE up to 6 RB. An integrated LPF is implemented to reject the PA and transceiver harmonics while at the same time minimizing any post PA loss for an optimized transmit current consumption. Out-of-band emissions performance is emphasized by the design to be 3GPP-compliant for Band 13 and Band 4.

Rx Section

Receive SAW filters are integrated in to the module along with the necessary matching, yielding a 50 Ω single-ended impedance for the antenna and Rx ports. The SAW filters provide a high level of rejection to out-of-band interferers protecting the transceiver from high blocking signal levels and to support 3GPP LTE blocking test conformance. The Rx SAW filters cascaded with the low throw count switch establishes a lower insertion loss and noise figure than conventional LTE receivers.

Smart Biasing

For most IoT applications, the DC-DC converter might not be available to control the VCC supply of the PA. With a fixed DC supply, Smart Biasing allows for easy power control through the MIPI interface by programming reduced bias current for lower gain states. Based on the application, a set of 4 to 6 different bias conditions with specific fixed-gain steps are predefined. For each of the steps, the transceiver output power can be adjusted to meet the desired total output power.

The key advantages of the smart biasing scheme are:

- Saving current consumption during lower output power operation
- Easy programming of fixed-gain steps through the MIPI interface
- Reducing the required output dynamic range of the transceiver

MIPI RFFE Controller Interface

The SKY68000-31 functional operation is fully controllable by a single MIPI interface which is used to drive the PA in various optimized bias modes as well as providing band selection and controlling the antenna switch Tx, Rx, and band selection.

Figure 1 shows the block diagram for the SKY68000-31.

Ordering Information

Part Number	Product Description	Evaluation Board Part Number
SKY68000-31	LTE Dual-Band Front-End Module for IoT	SKY68000-31EK1

Copyright © 2017-2018 Skyworks Solutions, Inc. All Rights Reserved.

Information in this document is provided in connection with Skyworks Solutions, Inc. (“Skyworks”) products or services. These materials, including the information contained herein, are provided by Skyworks as a service to its customers and may be used for informational purposes only by the customer. Skyworks assumes no responsibility for errors or omissions in these materials or the information contained herein. Skyworks may change its documentation, products, services, specifications or product descriptions at any time, without notice. Skyworks makes no commitment to update the materials or information and shall have no responsibility whatsoever for conflicts, incompatibilities, or other difficulties arising from any future changes.

No license, whether express, implied, by estoppel or otherwise, is granted to any intellectual property rights by this document. Skyworks assumes no liability for any materials, products or information provided hereunder, including the sale, distribution, reproduction or use of Skyworks products, information or materials, except as may be provided in Skyworks Terms and Conditions of Sale.

THE MATERIALS, PRODUCTS AND INFORMATION ARE PROVIDED “AS IS” WITHOUT WARRANTY OF ANY KIND, WHETHER EXPRESS, IMPLIED, STATUTORY, OR OTHERWISE, INCLUDING FITNESS FOR A PARTICULAR PURPOSE OR USE, MERCHANTABILITY, PERFORMANCE, QUALITY OR NON-INFRINGEMENT OF ANY INTELLECTUAL PROPERTY RIGHT; ALL SUCH WARRANTIES ARE HEREBY EXPRESSLY DISCLAIMED. SKYWORKS DOES NOT WARRANT THE ACCURACY OR COMPLETENESS OF THE INFORMATION, TEXT, GRAPHICS OR OTHER ITEMS CONTAINED WITHIN THESE MATERIALS. SKYWORKS SHALL NOT BE LIABLE FOR ANY DAMAGES, INCLUDING BUT NOT LIMITED TO ANY SPECIAL, INDIRECT, INCIDENTAL, STATUTORY, OR CONSEQUENTIAL DAMAGES, INCLUDING WITHOUT LIMITATION, LOST REVENUES OR LOST PROFITS THAT MAY RESULT FROM THE USE OF THE MATERIALS OR INFORMATION, WHETHER OR NOT THE RECIPIENT OF MATERIALS HAS BEEN ADVISED OF THE POSSIBILITY OF SUCH DAMAGE.

Skyworks products are not intended for use in medical, lifesaving or life-sustaining applications, or other equipment in which the failure of the Skyworks products could lead to personal injury, death, physical or environmental damage. Skyworks customers using or selling Skyworks products for use in such applications do so at their own risk and agree to fully indemnify Skyworks for any damages resulting from such improper use or sale.

Customers are responsible for their products and applications using Skyworks products, which may deviate from published specifications as a result of design defects, errors, or operation of products outside of published parameters or design specifications. Customers should include design and operating safeguards to minimize these and other risks. Skyworks assumes no liability for applications assistance, customer product design, or damage to any equipment resulting from the use of Skyworks products outside of stated published specifications or parameters.

Skyworks and the Skyworks symbol are trademarks or registered trademarks of Skyworks Solutions, Inc. or its subsidiaries in the United States and other countries. Third-party brands and names are for identification purposes only, and are the property of their respective owners. Additional information, including relevant terms and conditions, posted at www.skyworksinc.com, are incorporated by reference.

X-ON Electronics

Largest Supplier of Electrical and Electronic Components

Click to view similar products for [RF Front End](#) category:

Click to view products by [Skyworks](#) manufacturer:

Other Similar products are found below :

[SE2622L-R](#) [BGM1032N7E6327XUSA1](#) [LX5586LL](#) [SKY85703-11](#) [LX5586HLL](#) [LX5586ALL](#) [SKY66111-21](#) [SKY65728-11](#) [SKY68000-31](#)
[SKY85308-11](#) [SKY85302-11](#) [SKY65724-11](#) [ADTR1107ACCZ](#) [LMP91051MTX/NOPB](#) [SE5501L-R](#) [QPF4519SR](#) [SE5503A-R](#)
[ADA8282WBCPZ](#) [ADRF5545ABCPZN](#) [ADRF5545ABCPZN-R7](#) [AD8283WBCPZ](#) [AD8284WCSVZ](#) [ADRF5547BCPZN](#)
[ADRF5547BCPZN-R7](#) [ADRF5549BCPZN](#) [ADRF5549BCPZN-R7](#) [HV7350K6-G](#) [SE5516A-R](#) [MCP2030-I/SL](#) [MAX2009ETI+](#)
[MAX2078CTK+](#) [MAX2335ETI+](#) [MAX2678GTB/V+T](#) [MD2131K7-G](#) [MD2134K7-G](#) [RFFM6903TR13](#) [HV7351K6-G](#) [MCP2035-I/ST](#)
[SE2614BT-R](#) [SE2438T-R](#) [SST12LF02-QXCE](#) [SST12LF09-Q3CE](#) [RFX2401C](#) [RFX2402E](#) [SKY85201-11](#) [RFFM4591FTR7](#) [RFFM8211TR7](#)
[RFFM4293TR7](#) [RFFM4203TR7](#) [RFFM5765QTR7](#)