

PRODUCT SUMMARY

SKY68020-11: LTE Universal Multi-Band Front-End Module for IoT

Applications

- Low-power, low-data-rate cellular IoT
- Half-duplex operation (HD-FDD) LTE:
 - LTE-M
 - NB-IoT
- LTE universal modem products:
 - Low-band: 5, 8, 12, 13, 14, 17, 18, 19, 20, 26, 28, 71, 85
 - Mid-band: 1, 2, 3, 4, 25, 39, 66, 70

Features

- Output power: +24 dBm, optimized to support LTE for 1 RB to 6 RB
- Exceptional harmonics performance:
 - Band 13 2nd harmonic: -60 dBm/MHz
 - Band 28 2nd harmonic: -55 dBm/MHz
 - Band 28 3rd harmonic: -52 dBm/MHz
- Broadband PA supporting APT mode of operation or Vcc fixed supply: 2.85 V to 4.5 V
- Integrated Tx low-pass filters for optimized harmonic rejection
- Integrated SP6T antenna Tx/Rx switch
- Integrated Rx low-pass filters for out-of-band rejection
- Two broadband, high-power AUX ports for additional band support
- Low leakage current: 0.4 uA
- Adaptive biasing scheme for maximum PA efficiencies
- MIPI® RFFE control interface, 2.0 compliant
- Pin-to-pin compatible with the SKY68000-31, SKY68001-31, and SKY68001-41
- Operating temperature range: -40°C to +85°C
- Small, low-profile package (4 mm x 5 mm x 0.9 mm) (MSL3 @ 260 °C per JEDEC J-STD-020)



Skyworks Green™ products are compliant with all applicable legislation and are halogen-free. For additional information, refer to *Skyworks Definition of Green™*, document number SQ04-0074.

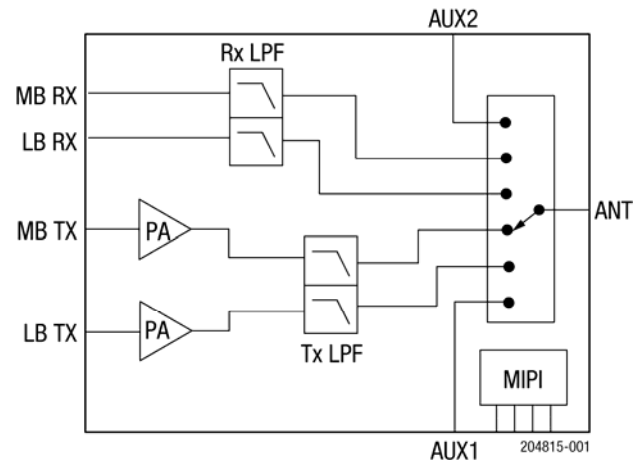

Figure 1. SKY68020-11 Functional Block Diagram

Description

The SKY68020-11 is a hybrid, multi-band multi-chip RF front-end (RFFE) module supporting cellular LTE-M/NB-IoT (half-duplex system) transceiver platforms. The module integrates the entire RF front end necessary for an LTE multi-band radio operating in low-band (5, 8, 12, 13, 14, 17, 18, 19, 20, 26, 28, 71, and 85), and mid-band (1, 2, 3, 4, 25, 39, 66, and 70) frequencies, including Rx low-pass filters, broadband PA with bias controller, Tx low-pass harmonic filter, antenna switch, and MIPI RFFE controller.

Tx Section

The PA load-line is optimized for high efficiency while simultaneously meeting 3GPP ACLR and emissions mask specifications with LTE up to 6 RB. An integrated LPF is implemented to reject the PA and transceiver harmonics while at the same time minimizing any post PA loss for an optimized transmit current consumption. Out-of-band emissions performance is emphasized by the design to be 3GPP-compliant for low-band (5, 8, 12, 13, 14, 17, 18, 19, 20, 26, 28, 71, and 85), and mid-band (1, 2, 3, 4, 25, 39, 66, and 70) frequencies.

Rx Section

Receive low-pass filters are integrated into the module along with the necessary matching to yield a 50 Ω single-ended impedance for the antenna and Rx ports. The filters provide a high level of rejection to out-of-band interferers, protecting the transceiver from high blocking signal levels and to support 3GPP LTE blocking test conformance. The Rx low-pass filters are cascaded with the low throw count switch to establish a lower insertion loss and noise figure than conventional LTE receivers.

Auxiliary Paths

The two AUX ports are additional broadband ports that can be used symmetrically for either Tx or Rx operation. The AUX ports can support conventional GSM power levels.

Smart Biasing

For most IoT applications, the DC-DC converter might not be available to control the VCC supply of the PA. With a fixed DC supply, Smart Biasing allows for easy power control through the MIPI interface by programming reduced bias current for lower gain states. Based on the application, a set of 4 to 6 different bias conditions with specific fixed-gain steps are predefined. For each of the steps, the transceiver output power can be adjusted to meet the desired total output power.

The key advantages of the smart biasing scheme are:

- Saving current consumption during lower output power operation
- Easy programming of fixed-gain steps through the MIPI interface
- Reducing the required output dynamic range of the transceiver

MIPI RFFE Controller Interface

The SKY68020-11 functional operation is fully controllable by a single MIPI interface which is used to drive the PA in various optimized bias modes as well as providing band selection and controlling the antenna switch Tx, Rx, and band selection.

Figure 1 shows the block diagram for the SKY68020-11.

Ordering Information

Part Number	Product Description	Evaluation Board Part Number
SKY68020-11	LTE Universal Multi-Band Front-End Module for IoT	SKY68020-11EK1

Copyright © 2018 Skyworks Solutions, Inc. All Rights Reserved.

Information in this document is provided in connection with Skyworks Solutions, Inc. (“Skyworks”) products or services. These materials, including the information contained herein, are provided by Skyworks as a service to its customers and may be used for informational purposes only by the customer. Skyworks assumes no responsibility for errors or omissions in these materials or the information contained herein. Skyworks may change its documentation, products, services, specifications or product descriptions at any time, without notice. Skyworks makes no commitment to update the materials or information and shall have no responsibility whatsoever for conflicts, incompatibilities, or other difficulties arising from any future changes.

No license, whether express, implied, by estoppel or otherwise, is granted to any intellectual property rights by this document. Skyworks assumes no liability for any materials, products or information provided hereunder, including the sale, distribution, reproduction or use of Skyworks products, information or materials, except as may be provided in Skyworks Terms and Conditions of Sale.

THE MATERIALS, PRODUCTS AND INFORMATION ARE PROVIDED “AS IS” WITHOUT WARRANTY OF ANY KIND, WHETHER EXPRESS, IMPLIED, STATUTORY, OR OTHERWISE, INCLUDING FITNESS FOR A PARTICULAR PURPOSE OR USE, MERCHANTABILITY, PERFORMANCE, QUALITY OR NON-INFRINGEMENT OF ANY INTELLECTUAL PROPERTY RIGHT; ALL SUCH WARRANTIES ARE HEREBY EXPRESSLY DISCLAIMED. SKYWORKS DOES NOT WARRANT THE ACCURACY OR COMPLETENESS OF THE INFORMATION, TEXT, GRAPHICS OR OTHER ITEMS CONTAINED WITHIN THESE MATERIALS. SKYWORKS SHALL NOT BE LIABLE FOR ANY DAMAGES, INCLUDING BUT NOT LIMITED TO ANY SPECIAL, INDIRECT, INCIDENTAL, STATUTORY, OR CONSEQUENTIAL DAMAGES, INCLUDING WITHOUT LIMITATION, LOST REVENUES OR LOST PROFITS THAT MAY RESULT FROM THE USE OF THE MATERIALS OR INFORMATION, WHETHER OR NOT THE RECIPIENT OF MATERIALS HAS BEEN ADVISED OF THE POSSIBILITY OF SUCH DAMAGE.

Skyworks products are not intended for use in medical, lifesaving or life-sustaining applications, or other equipment in which the failure of the Skyworks products could lead to personal injury, death, physical or environmental damage. Skyworks customers using or selling Skyworks products for use in such applications do so at their own risk and agree to fully indemnify Skyworks for any damages resulting from such improper use or sale.

Customers are responsible for their products and applications using Skyworks products, which may deviate from published specifications as a result of design defects, errors, or operation of products outside of published parameters or design specifications. Customers should include design and operating safeguards to minimize these and other risks. Skyworks assumes no liability for applications assistance, customer product design, or damage to any equipment resulting from the use of Skyworks products outside of stated published specifications or parameters.

Skyworks and the Skyworks symbol are trademarks or registered trademarks of Skyworks Solutions, Inc. or its subsidiaries in the United States and other countries. Third-party brands and names are for identification purposes only, and are the property of their respective owners. Additional information, including relevant terms and conditions, posted at www.skyworksinc.com, are incorporated by reference.

X-ON Electronics

Largest Supplier of Electrical and Electronic Components

Click to view similar products for [RF Development Tools](#) category:

Click to view products by [Skyworks](#) manufacturer:

Other Similar products are found below :

[MAAM-011117](#) [MAAP-015036-DIEEV2](#) [EV1HMC1113LP5](#) [EV1HMC6146BLC5A](#) [EV1HMC637ALP5](#) [EVAL-ADG919EBZ](#) [ADL5363-EVALZ](#) [LMV228SDEVAL](#) [SKYA21001-EVB](#) [SMP1331-085-EVB](#) [EV1HMC618ALP3](#) [EVAL01-HMC1041LC4](#) [MAAL-011111-000SMB](#) [MAAM-009633-001SMB](#) [MASW-000936-001SMB](#) [107712-HMC369LP3](#) [107780-HMC322ALP4](#) [SP000416870](#) [EV1HMC470ALP3](#) [EV1HMC520ALC4](#) [EV1HMC244AG16](#) [MAX2614EVKIT#](#) [124694-HMC742ALP5](#) [SC20ASATEA-8GB-STD](#) [MAX2837EVKIT+](#) [MAX2612EVKIT#](#) [MAX2692EVKIT#](#) [EV1HMC629ALP4E](#) [SKY12343-364LF-EVB](#) [108703-HMC452QS16G](#) [EV1HMC863ALC4](#) [119197-HMC658LP2](#) [EV1HMC647ALP6](#) [ADL5725-EVALZ](#) [106815-HMC441LM1](#) [EV1HMC1018ALP4](#) [UXN14M9PE](#) [MAX2016EVKIT](#) [EV1HMC939ALP4](#) [MAX2410EVKIT](#) [MAX2204EVKIT+](#) [EV1HMC8073LP3D](#) [SIMSA868-DKL](#) [SIMSA868C-DKL](#) [SKY65806-636EK1](#) [SKY68020-11EK1](#) [SKY67159-396EK1](#) [SKY66181-11-EK1](#) [SKY65804-696EK1](#) [SKY13396-397LF-EVB](#)