



PRELIMINARY DATA SHEET

SKY73420-11: 650 to 950 MHz Broadband, Application Configurable High Gain and Linearity Diversity Downconversion Mixer

Applications

- 2G/3G/4G base station transceivers:
 - GSM/EDGE, CDMA, UMTS/WCDMA, LTE
- Land mobile radio
- High performance radio links

Features

- Operating frequency range: 650 to 950 MHz
- IF frequency range: 150 to 400 MHz
- Conversion gain: 8.1 dB
- Input IP3: up to +25.6 dBm
- Noise figure: 9.3 dB
- Power-down mode
- Integrated LO drivers
- Integrated low-loss RF baluns
- High-linearity IF amplifiers
- Application tuneability
- Small, QFN (36-pin, 6 x 6 mm) package (MSL3, 260 °C per JEDEC J-STD-020)



Skyworks Green™ products are compliant with all applicable legislation and are halogen-free. For additional information, refer to *Skyworks Definition of Green™*, document number SQ04-0074.

Table 1. Pin-to-Pin Compatible Mixer Family

Part Number	RF Frequency (MHz)	LO Frequency (MHz)	IF Frequency (MHz)
SKY73420-11	650 to 950	750 to 1350	100 to 400
SKY73421-11	1400 to 2000	1100 to 1900	100 to 350
SKY73422-11	1700 to 2700	2000 to 2550	100 to 400

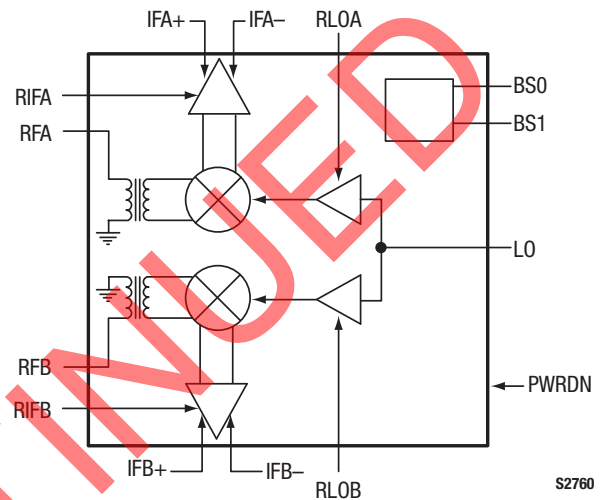

Figure 1. SKY73420-11 Block Diagram

Description

The SKY73420-11 is a fully integrated diversity mixer that includes local oscillator (LO) drivers, high linearity mixers, and large dynamic range intermediate frequency (IF) amplifiers. Low loss RF baluns have also been included to reduce design complications and lower system cost.

The SKY73420-11 features an IIP3 of up to +25.6 dBm and a noise figure (NF) of 9.3 dB, making the device an ideal solution for high dynamic range systems such as 2G/3G/4G base station receivers.

The SKY73420-11 has been designed for optimum long-term reliability. The SKY73420-11 diversity downconversion mixer is provided in a compact, 36-pin Quad Flat No-Lead (QFN) package. A functional block diagram is shown in Figure 1. The pin configuration and package are shown in Figure 2. Table 1 lists the part numbers of pin-compatible parts belonging to this family of mixers. Signal pin assignments and functional pin descriptions are provided in Table 2.

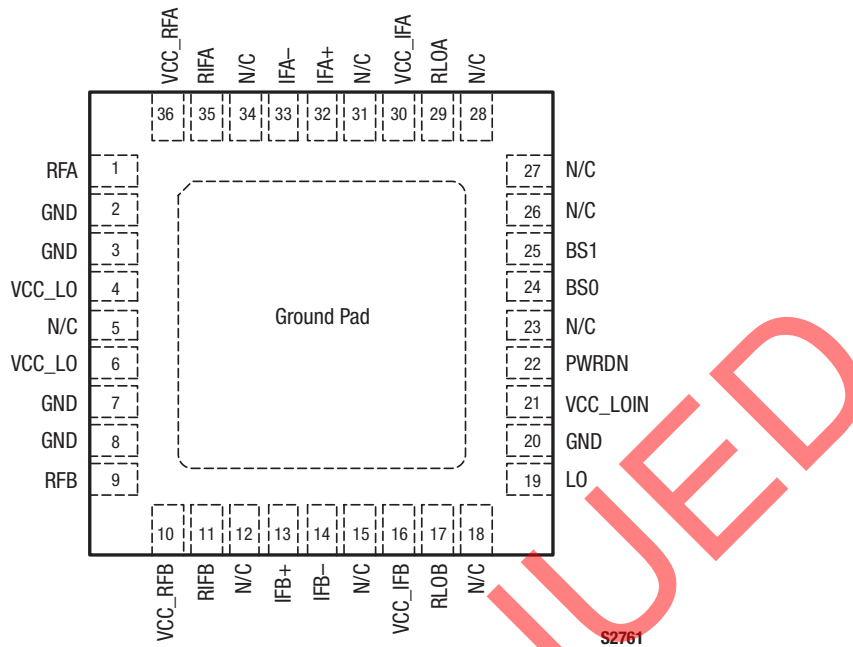

Figure 2. SKY73420-11 Pinout – 36-Pin QFN (Top View)

Table 2. SKY73420-11 Signal Descriptions

Pin	Name	Description	Pin	Name	Description
1	RFA	RF channel A input	19	LO	Local oscillator input
2	GND	Ground	20	GND	Ground
3	GND	Ground	21	VCC_LOIN	DC supply, +5 V
4	VCC_LO	DC supply, +5 V	22	PWRDN	Power-down mode enable
5	N/C	No internal connection	23	N/C	No internal connection
6	VCC_LO	DC supply, +5 V	24	BS0	Band select 0 control
7	GND	Ground	25	BS1	Band select 1 control
8	GND	Ground	26	N/C	No internal connection
9	RFB	RF channel B input	27	N/C	No internal connection
10	VCC_RFB	DC supply, +5 V	28	N/C	No internal connection
11	RIFB	IF channel B bias control	29	RLOA	LO channel A bias control
12	N/C	No internal connection	30	VCC_IFA	DC supply, +5 V
13	IFB+	IF channel B positive output	31	N/C	No internal connection
14	IFB-	IF channel B negative output	32	IFA+	IF channel A positive output
15	N/C	No internal connection	33	IFA-	IF channel A negative output
16	VCC_IFB	DC supply, +5 V	34	N/C	No internal connection
17	RLOB	LO channel B bias control	35	RIFA	IF channel A bias control
18	N/C	No internal connection	36	VCC_RFA	DC supply, +5 V
			-	Ground pad	Bottom ground pad (Note 1)

Note 1: Bottom ground pad serves as a key electrical and thermal ground.

Functional Description

The SKY73420-11 is a high gain diversity mixer, optimized for base station receiver applications. The device consists of two diversity channels, each consisting of a low-loss RF balun, high-linearity passive mixer, and a low-noise IF amplifier.

The SKY73420-11 also includes a power-down feature used to lower the supply current for standby operation (refer to Tables 5 and 6):

PWRDN Logic:	Mixer State:
High	Standby (low power mode)
Low	Full operation

LO amplifiers are also included that allow the SKY73420-11 to connect directly to the output of a Voltage Controlled Oscillator (VCO). This eliminates the extra gain stages needed by most discrete passive mixers.

RF Baluns and Passive Mixer

The RF baluns provide a single ended input, which can easily be matched to 50 Ω using a simple matching circuit. The RF baluns offer very low loss and excellent amplitude and phase balance over a wide frequency range of 650 to 950 MHz.

The high linearity mixer is a passive, double balanced mixer that provides a very low insertion loss, and excellent 3rd Order Input Insertion Point (IIP3) and linearity performance.

Additionally, the balanced nature of the mixer provides for excellent port-to-port isolation.

Bandselect Logic

The SKY73420-11 is designed to optimize performance in four sub-bands. The particular sub-band of interest is selected by setting pin 24 (BS0) and pin 25 (BS1). The bandselect logic is provided in Table 3.

Depending on the LO injection side, and the RF and IF frequencies involved, there could be multiple bandselect solutions. Table 6 identifies recommended bandselects for a number of frequency ranges.

Table 3. SKY73420-11 Bandselect Logic

BS1 (Pin 25)	BS0 (Pin 24)	LO Center Frequency (MHz)
0	0	*** TBD ***
0	1	*** TBD ***
1	0	*** TBD ***
1	1	*** TBD ***

LO Buffers

The LO buffers allow the input power of the SKY73420-11 to be driven in the range of -6 to +6 dBm. The LO section has been optimized for 800 to 1350 MHz. However, the LO can be driven over a wide frequency range with only slight degradation in performance.

Pins 17 (RLOB) and 29 (RLOA) allow for external biasing of the LO driver bias currents to trade off linearity for the core passive mixer current.

Power-Down Mode

The SKY73420-11 also includes a low current power-down mode controlled by pin 22 (PWRDN). When this pin is at a logic high level, the power-down function is enabled with the total mixer current under 45 mA.

IF Amplifier

The SKY73420-11 includes high dynamic range IF amplifiers that follow the passive mixers in the signal path. The outputs require a supply voltage connection using inductive chokes. These choke inductors should be high-Q and have the ability to handle 200 mA or greater.

A simple matching network allows the output ports to be matched to a balanced 200 Ω impedance. The IF amplifiers are optimized for IF frequencies between 100 and 400 MHz. The IF amplifiers can be operated outside of this range, but with a slight degradation in performance.

Pins 11 (RIFB) and 35 (RIFA) allow for external biasing of the IF amplifier bias currents to trade off linearity for the IF amplifier current.

Electrical and Mechanical Specifications

The absolute maximum ratings of the SKY73420-11 are provided in Table 4. The recommended operating conditions are specified in Table 5 and electrical specifications are provided in Tables 6 and 7.

Table 4. SKY73420-11 Absolute Maximum Ratings

Parameter	Symbol	Minimum	Maximum	Units
Supply voltage, +5 V (VCC_LO, VCC_RFA, VCC_RFB, VCC_IFA, VCC_IFB, VCC_LOIN)	Vcc	4.5	5.5	V
Total supply current	Icc		360	mA
RF input power	PRF		+20	dBm
LO input power	PLO		+20	dBm
Operating case temperature	Tc	-40	+100	°C
Junction temperature	TJ		+125	°C
Storage case temperature	TSTG	-40	+150	°C
Thermal resistance	ΘJC		10.4	°C/W

Notes: Exposure to maximum rating conditions for extended periods may reduce device reliability. There is no damage to device with only one parameter set at the limit and all other parameters set at or below their nominal value. Exceeding any of the limits listed here may result in permanent damage to the device.

CAUTION: Although this device is designed to be as robust as possible, electrostatic discharge (ESD) can damage this device. This device must be protected at all times from ESD. Static charges may easily produce potentials of several kilovolts on the human body or equipment, which can discharge without detection. Industry-standard ESD precautions should be used at all times.

Table 5. SKY73420-11 Recommended Operating Conditions

Parameter	Symbol	Minimum	Typical	Maximum	Units
RF frequency range	f _{RF}	650		950	MHz
LO frequency range	f _{LO}	800		1350	MHz
IF frequency range	f _{IF}	100		400	MHz
Supply voltage, +5 V	Vcc	4.75	5.00	5.25	V
Supply current (Note 1), PWRDN = 0 V	Icc		310		mA
LO input power	PLo	-6	0	+6	dBm
Logic levels (Note 2):					
high	V _{IN_H}	1.09		Vcc	V
low	V _{IN_L}	0		0.74	V
Logic input current	I _L	*** TBD ***	0	*** TBD ***	mA
Operating case temperature (Note 3)	Tc	-40		+100	°C

Note 1: See Table 7 for external biasing and matching components.

Note 2: Logic signals are: PWRDN, BS0, and BS1. Valid logic levels must be applied. There are no internal pull-ups or pull-downs.

Note 3: Case temperature measured at bottom of package where device is soldered to board.

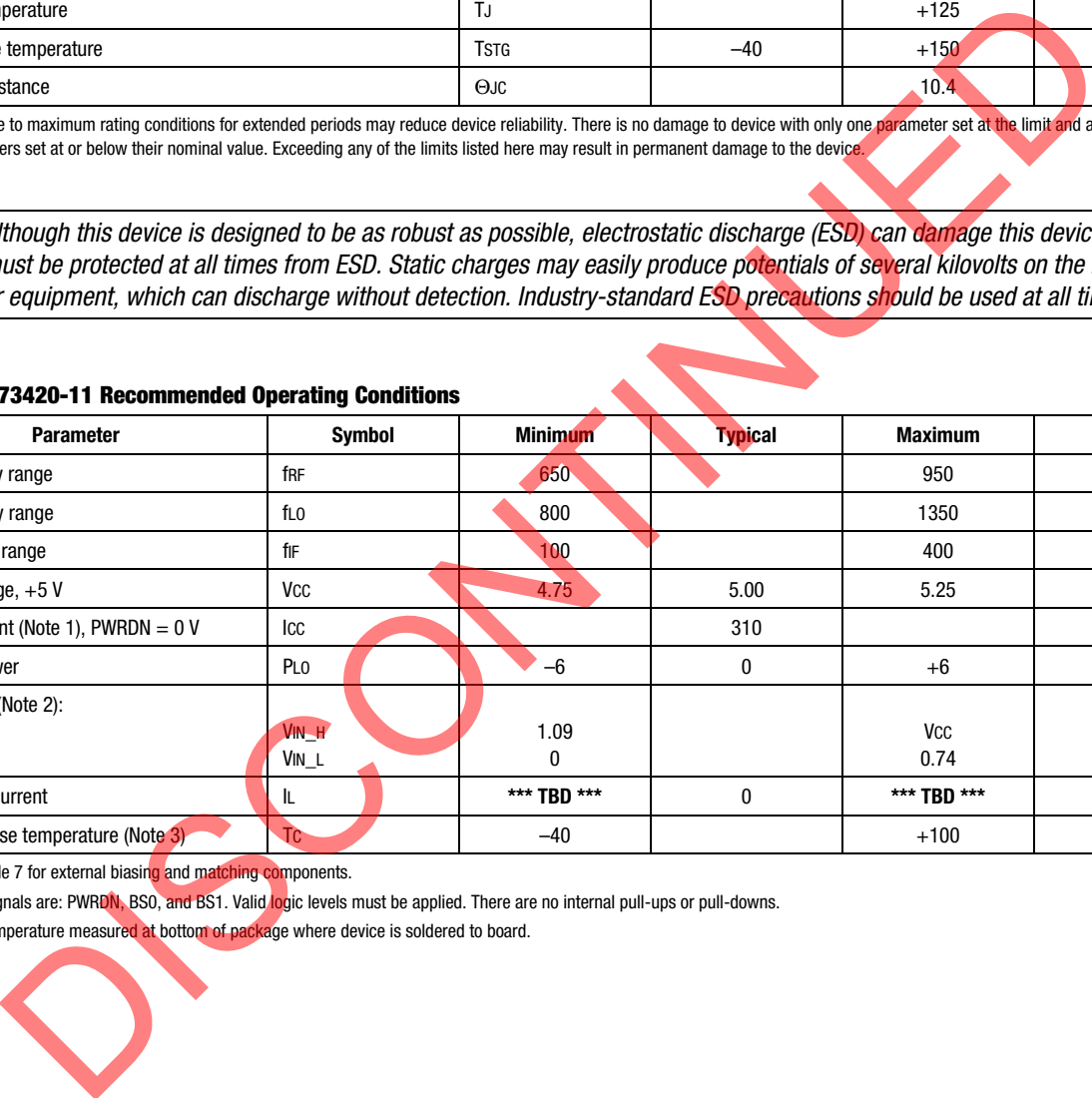

Table 6. SKY73420-11 Electrical Specifications: General (1 of 5) (Note 1)
(V_{CC} = 4.75 to 5.25 V, T_c = -40 to +100 °C, P_{LO} = -3 to +3 dBm, PWRDN = Logic "0," Unless Otherwise Noted)

Parameter	Symbol	Test Condition				Min	Typical	Max	Units
		RF Freq Range (MHz)	IF Freq (MHz)	BS1	BS0				
Conversion gain	G	824 to 849	200	0	1		8.1		dB
		824 to 849	350	0	1		8.0		dB
		830 to 862	200	1	1				dB
		830 to 862	350	1	1				dB
		880 to 915	200	0	1				dB
		880 to 915	350	0	1				dB
		698 to 716	200	1	1				dB
		698 to 716	350	1	1				dB
		777 to 798	200	1	1				dB
		777 to 798	350	1	1				dB
Noise figure	NF	824 to 849	200	0	1		9.3	11.0	dB
		824 to 849	350	0	1		9.3	11.0	dB
		830 to 862	200	1	1				dB
		830 to 862	350	1	1				dB
		880 to 915	200	0	1				dB
		880 to 915	350	0	1				dB
		698 to 716	200	1	1				dB
		698 to 716	350	1	1				dB
		777 to 798	200	1	1				dB
		777 to 798	350	1	1				dB
3 rd Order input intercept point	IIP3	824 to 849	200	0	1	+23.5	+25.6		dBm
		824 to 849	350	0	1	+23.5	+25.6		dBm
		830 to 862	200	1	1	+23.5			dBm
		830 to 862	350	1	1	+23.5			dBm
		880 to 915	200	0	1	+23.5			dBm
		880 to 915	350	0	1	+23.5			dBm
		698 to 716	200	1	1	+23.5			dBm
		698 to 716	350	1	1	+23.5			dBm
		777 to 798	200	1	1	+23.5			dBm
		777 to 798	350	1	1	+23.5			dBm

Table 6. SKY73420-11 Electrical Specifications: General (2 of 5) (Note 1)
 (V_{cc} = 4.75 to 5.25 V, T_c = -40 to +100 °C, P_{Lo} = -3 to +3 dBm, PWRDN = Logic “0,” Unless Otherwise Noted)

Parameter	Symbol	Test Condition				Min	Typical	Max	Units
		RF Freq Range (MHz)	IF Freq (MHz)	BS1	BS0				
Operating current (on)	I _{cc_ON}	824 to 849	200	0	1		317		mA
		824 to 849	350	0	1		329		mA
		830 to 862	200	1	1				mA
		830 to 862	350	1	1				mA
		880 to 915	200	0	1				mA
		880 to 915	350	0	1				mA
		698 to 716	200	1	1				mA
		698 to 716	350	1	1				mA
		777 to 798	200	1	1				mA
		777 to 798	350	1	1				mA
Operating current (off) (Note 2)	I _{cc_OFF}	824 to 849	200	0	1		34		mA
		824 to 849	350	0	1		34		mA
		830 to 862	200	1	1				mA
		830 to 862	350	1	1				mA
		880 to 915	200	0	1				mA
		880 to 915	350	0	1				mA
		698 to 716	200	1	1				mA
		698 to 716	350	1	1				mA
		777 to 798	200	1	1				mA
		777 to 798	350	1	1				mA
Input 1 dB compression point	IP1dB	824 to 849	200	0	1	+10.0	+12.9		dBm
		824 to 849	350	0	1	+10.0	+13.7		dBm
		830 to 862	200	1	1	+10.0			dBm
		830 to 862	350	1	1	+10.0			dBm
		880 to 915	200	0	1	+10.0			dBm
		880 to 915	350	0	1	+10.0			dBm
		698 to 716	200	1	1	+10.0			dBm
		698 to 716	350	1	1	+10.0			dBm
		777 to 798	200	1	1	+10.0			dBm
		777 to 798	350	1	1	+10.0			dBm



Table 6. SKY73420-11 Electrical Specifications: General (3 of 5) (Note 1)
(V_{CC} = 4.75 to 5.25 V, T_C = -40 to +100 °C, P_{LO} = -3 to +3 dBm, PWRDN = Logic "0," Unless Otherwise Noted)

Parameter	Symbol	Test Condition				Min	Typical	Max	Units
		RF Freq Range (MHz)	IF Freq (MHz)	BS1	BS0				
1xLO to RF leakage (measured @ LO)	1xLO-RF	824 to 849	200	0	1		-48	-25	dBm
		824 to 849	350	0	1		-48	-25	dBm
		830 to 862	200	1	1			-25	dBm
		830 to 862	350	1	1			-25	dBm
		880 to 915	200	0	1			-25	dBm
		880 to 915	350	0	1			-25	dBm
		698 to 716	200	1	1			-25	dBm
		698 to 716	350	1	1			-25	dBm
		777 to 798	200	1	1			-25	dBm
		777 to 798	350	1	1			-25	dBm
2xLO to RF leakage (measured @ 2xLO)	2xLO-RF	824 to 849	200	0	1		-48	-25	dBm
		824 to 849	350	0	1		-41	-25	dBm
		830 to 862	200	1	1			-25	dBm
		830 to 862	350	1	1			-25	dBm
		880 to 915	200	0	1			-25	dBm
		880 to 915	350	0	1			-25	dBm
		698 to 716	200	1	1			-25	dBm
		698 to 716	350	1	1			-25	dBm
		777 to 798	200	1	1			-25	dBm
		777 to 798	350	1	1			-25	dBm
3xLO to RF leakage (measured @ 3xLO)	3xLO-RF	824 to 849	200	0	1		-65	-28	dBm
		824 to 849	350	0	1		-65	-28	dBm
		830 to 862	200	1	1			-28	dBm
		830 to 862	350	1	1			-28	dBm
		880 to 915	200	0	1			-28	dBm
		880 to 915	350	0	1			-28	dBm
		698 to 716	200	1	1			-28	dBm
		698 to 716	350	1	1			-28	dBm
		777 to 798	200	1	1			-28	dBm
		777 to 798	350	1	1			-28	dBm

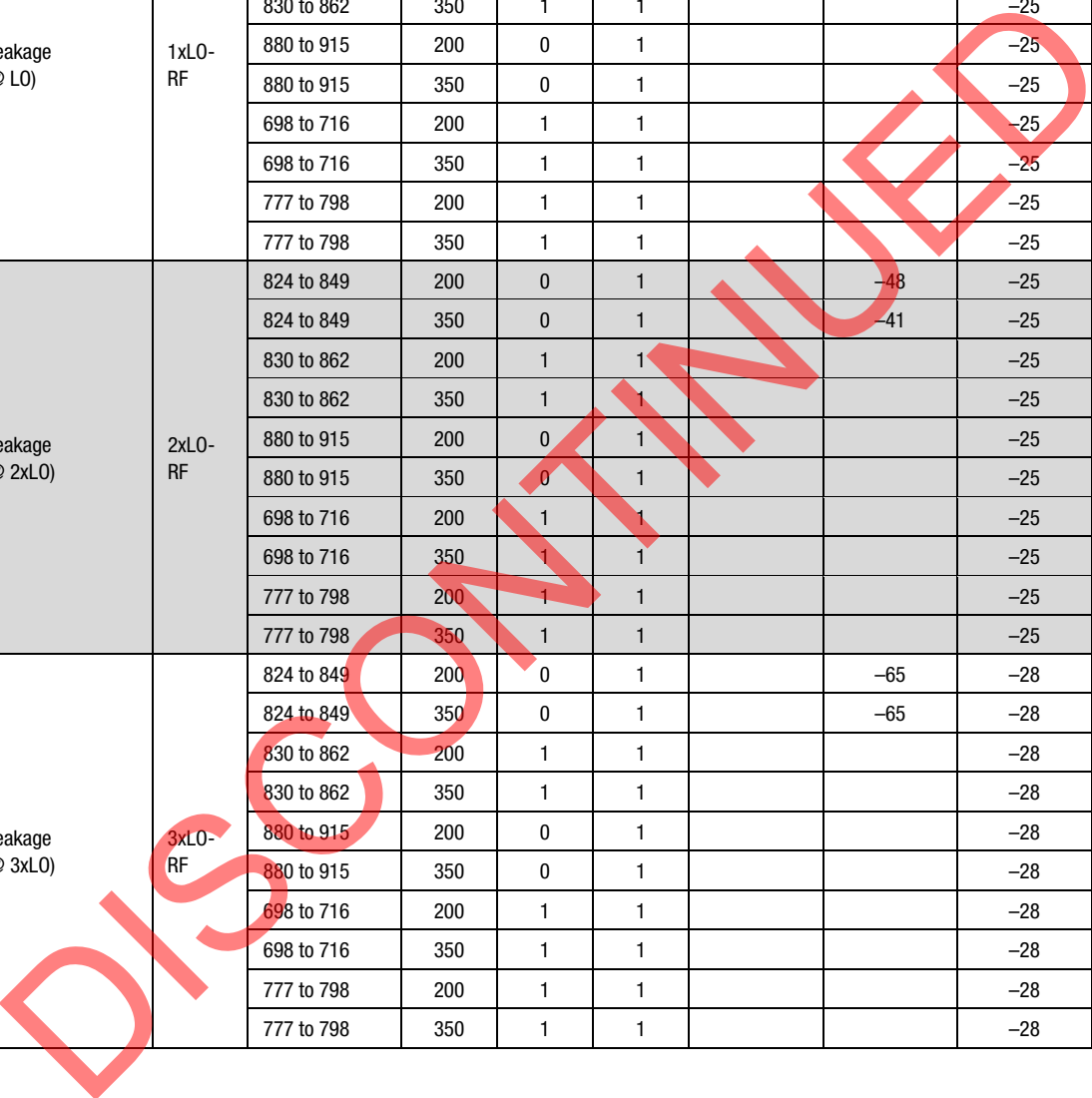

Table 6. SKY73420-11 Electrical Specifications: General (4 of 5) (Note 1)
 (V_{CC} = 4.75 to 5.25 V, T_c = -40 to +100 °C, P_{LO} = -3 to +3 dBm, PWRDN = Logic “0,” Unless Otherwise Noted)

Parameter	Symbol	Test Condition				Min	Typical	Max	Units
		RF Freq Range (MHz)	IF Freq (MHz)	BS1	BS0				
4xLO to RF leakage (measured @ 4xLO)	4xLO- RF	824 to 849	200	0	1		-21		dBm
		824 to 849	350	0	1		-21		dBm
		830 to 862	200	1	1				dBm
		830 to 862	350	1	1				dBm
		880 to 915	200	0	1				dBm
		880 to 915	350	0	1				dBm
		698 to 716	200	1	1				dBm
		698 to 716	350	1	1				dBm
		777 to 798	200	1	1				dBm
		777 to 798	350	1	1				dBm
2RF – 2LO (Note 3)	2x2	824 to 849	200	0	1		-82	-63	dBc
		824 to 849	350	0	1		-78	-63	dBc
		830 to 862	200	1	1				dBc
		830 to 862	350	1	1				dBc
		880 to 915	200	0	1				dBc
		880 to 915	350	0	1				dBc
		698 to 716	200	1	1				dBc
		698 to 716	350	1	1				dBc
		777 to 798	200	1	1				dBc
		777 to 798	350	1	1				dBc
3RF – 3LO (Note 3)	3x3	824 to 849	200	0	1		-86	-70	dBc
		824 to 849	350	0	1		-85	-70	dBc
		830 to 862	200	1	1				dBc
		830 to 862	350	1	1				dBc
		880 to 915	200	0	1				dBc
		880 to 915	350	0	1				dBc
		698 to 716	200	1	1				dBc
		698 to 716	350	1	1				dBc
		777 to 798	200	1	1				dBc
		777 to 798	350	1	1				dBc

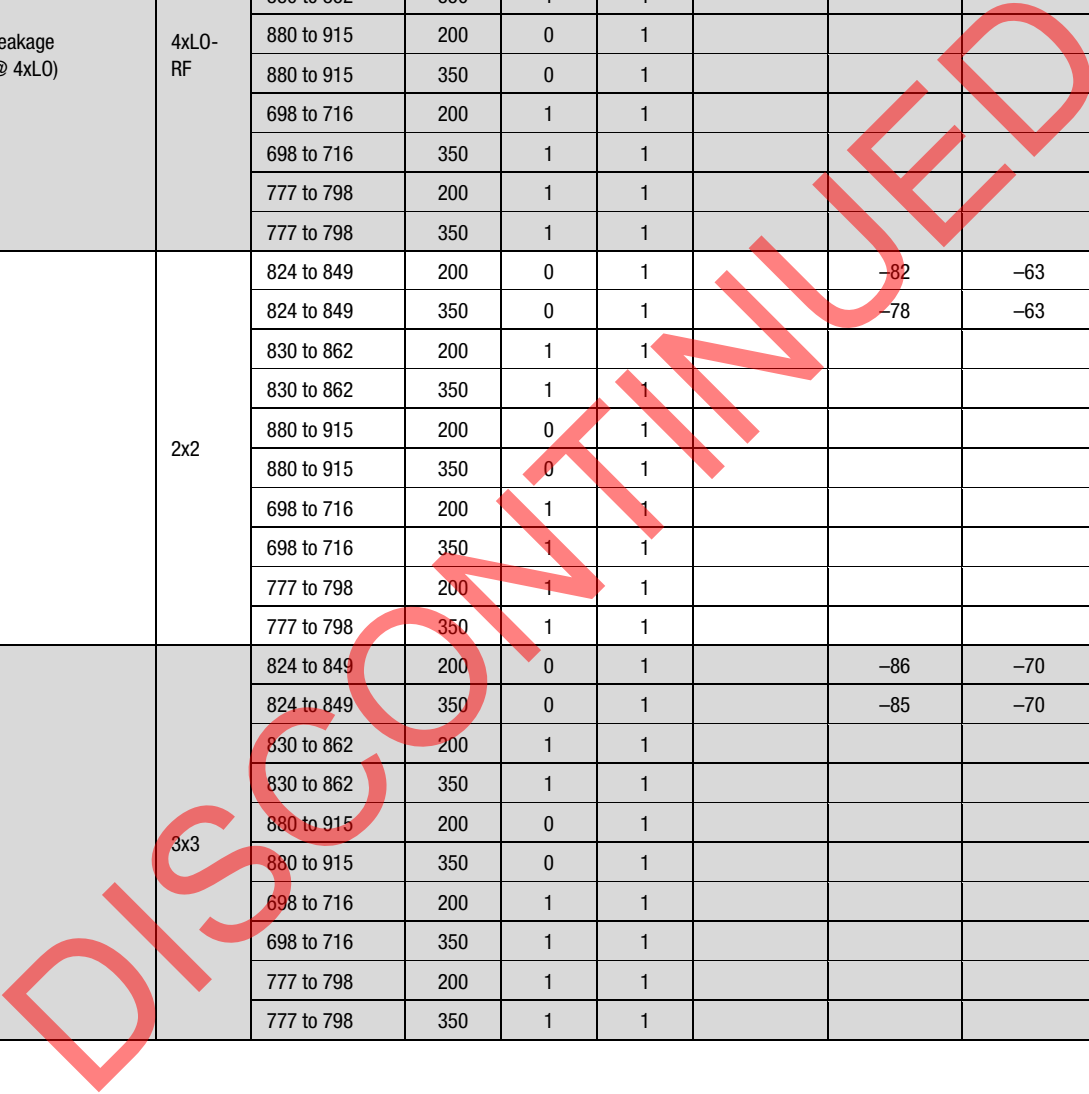

Table 6. SKY73420-11 Electrical Specifications: General (5 of 5) (Note 1)
(V_{CC} = 4.75 to 5.25 V, T_C = -40 to +100 °C, P_{LO} = -3 to +3 dBm, PWRDN = Logic "0," Unless Otherwise Noted)

Parameter	Symbol	Test Condition				Min	Typical	Max	Units
		RF Freq Range (MHz)	IF Freq (MHz)	BS1	BS0				
LO to IF (leakage measured @ LO)	LO-IF	824 to 849	200	0	1		-58	-23	dBm
		824 to 849	350	0	1		-53	-23	dBm
		830 to 862	200	1	1			-23	dBm
		830 to 862	350	1	1			-23	dBm
		880 to 915	200	0	1			-23	dBm
		880 to 915	350	0	1			-23	dBm
		698 to 716	200	1	1			-23	dBm
		698 to 716	350	1	1			-23	dBm
		777 to 798	200	1	1			-23	dBm
		777 to 798	350	1	1			-23	dBm
RF to IF (isolation measured @ RF)	RF-IF	824 to 849	200	0	1		44	30	dB
		824 to 849	350	0	1		45	30	dB
		830 to 862	200	1	1			30	dB
		830 to 862	350	1	1			30	dB
		880 to 915	200	0	1			30	dB
		880 to 915	350	0	1			30	dB
		698 to 716	200	1	1			30	dB
		698 to 716	350	1	1			30	dB
		777 to 798	200	1	1			30	dB
		777 to 798	350	1	1			30	dB
Channel to channel (isolation measured @ IF)	Ch-Ch	824 to 849	200	0	1		70	40	dB
		824 to 849	350	0	1		72	40	dB
		830 to 862	200	1	1			40	dB
		830 to 862	350	1	1			40	dB
		880 to 915	200	0	1			40	dB
		880 to 915	350	0	1			40	dB
		698 to 716	200	1	1			40	dB
		698 to 716	350	1	1			40	dB
		777 to 798	200	1	1			40	dB
		777 to 798	350	1	1			40	dB

Note 1: Performance is guaranteed only under the conditions listed in this Table. Production tested: RF frequency = *** TBD *** MHz, LO frequency = *** TBD *** MHz. All others guaranteed by design and characterization. Testing conducted with balun on IF output (see Figure 5). Table 1 performance is of the DUT, with balun loss de-embedded.

Input matching can be unique for each bandselect setting.

Conditions for typical values: V_{CC} = 5 V, T_C = +35 °C, P_{LO} = 0 dBm, middle of RF range.

See Table 7 for external biasing and matching components.

Note 2: PWRDN pin = logic "1."

Note 3: Interferer tone is -10 dBm.

Table 7. SKY73420-11 Electrical Specifications (Note 1)

(V_{CC} = 4.75 to 5.25 V, T_C = -40 to +100 °C, P_{LO} = -3 to +3 dBm, P_{WRDN} = Logic “0,” BS0/BS1 = Logic “1,” P_{RF} = -10 dBm, f_{IF} = 200 MHz, Unless Otherwise Noted)

Parameter	Symbol	Test Condition	Min	Typical	Max	Units
Noise figure with a blocker signal (Note 2)	NFBLK	Blocking signal input power = +8 dBm, 2.5 MHz offset		*** TBD ***		dB
Power-up time (Note 2) (Note 3)	tON			*** TBD ***	1	μs
Power-down time (Note 2) (Note 4)	tOFF			*** TBD ***	1	μs
RF port input return loss (Note 2)	Z _{IN_RF}	With external matching components	14			dB
LO port input return loss (Note 2)	Z _{IN_LO}	With external matching components	14			dB
IF port input return loss (Note 2)	Z _{OUT_IF}	With external matching components	14			dB

Note 1: Performance is guaranteed only under the conditions listed in this table. Production tested: RF frequency = *** TBD *** MHz, LO frequency = *** TBD *** MHz. All others guaranteed by design and characterization. Testing conducted with balun on IF output (see Figure 5). Table 1 performance is of the DUT, with balun loss de-embedded.

Input matching can be unique for each bandselect setting.

Conditions for typical values: V_{CC} = 5 V, T_C = +35 °C, P_{LO} = 0 dBm, middle of RF range.

See Table 8 for external biasing and matching components.

Note 2: Not production tested. Guaranteed by design and characterization.

Note 3: Time required for IF envelope to reach 97.5% of final value following a PWRDN transition to logic “0” with t_{FALL} < 1 ns.

Note 4: Time required for total supply current to be less than 53 mA following a PWRDN transition to logic “1” with t_{RISE} < 1 ns.

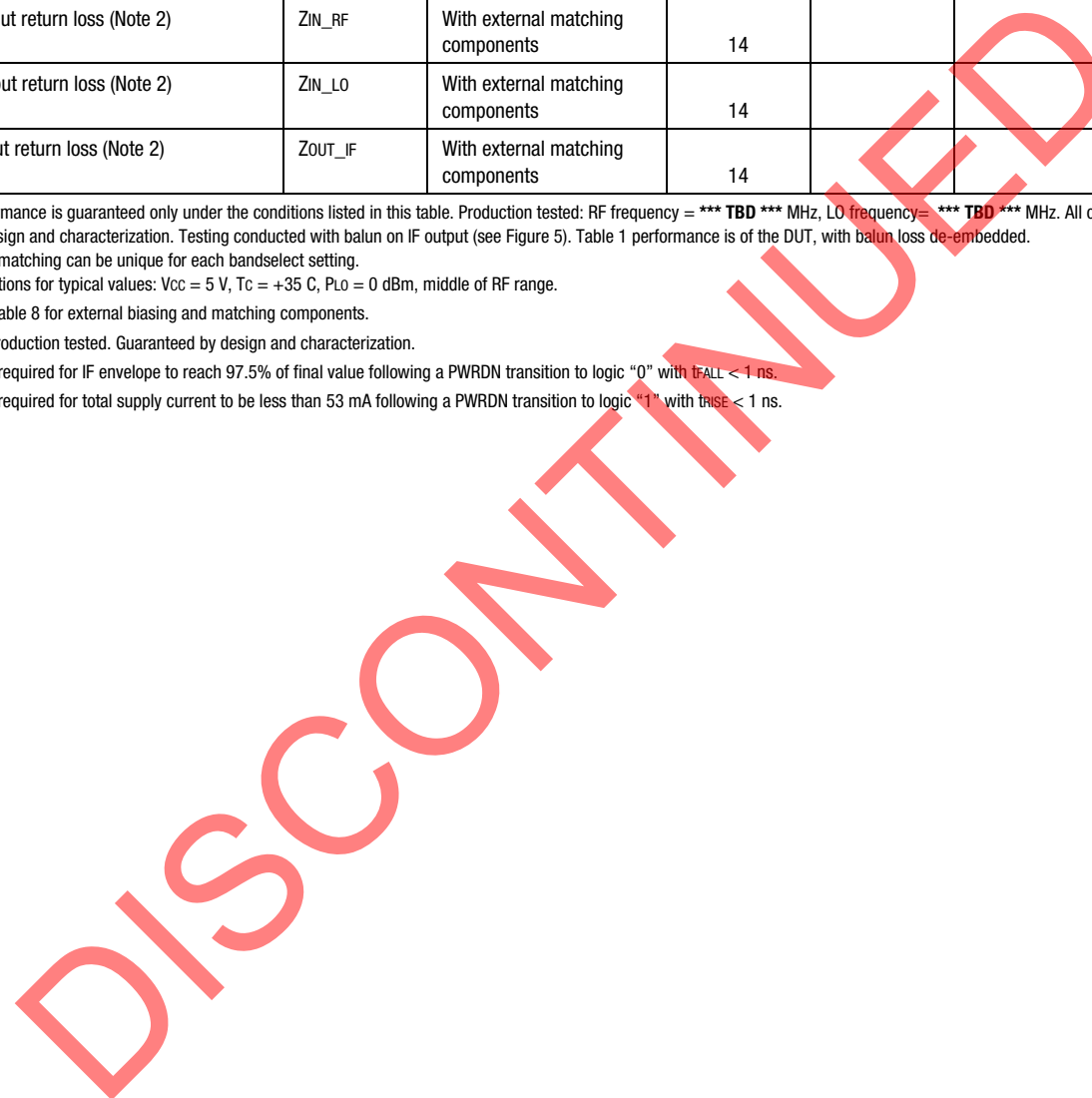

Evaluation Board Description

The SKY73420-11 Evaluation Board is used to test the performance of the SKY73420-11 downconversion mixer. An assembly drawing for the Evaluation Board is shown in Figure 3 and the layer detail is provided in Figure 4. A schematic diagram of the SKY73420-11 Evaluation Board is shown in Figure 5.

RF and IF matching components are listed in Table 8.

Circuit Design Considerations

The following design considerations are general in nature and must be followed regardless of final use or configuration:

- Paths to ground should be made as short as possible.
- The ground pad of the SKY73420-11 has special electrical and thermal grounding requirements. This pad is the main thermal conduit for heat dissipation. Since the circuit board acts as the heat sink, it must shunt as much heat as possible from the device. Therefore, design the connection to the ground pad to dissipate the maximum wattage produced by the circuit board.
- Skyworks recommends including external bypass capacitors on the VCC voltage inputs of the device.
- Components L12, L13, L14, and L15 (see Figure 5) are high-Q low loss inductors. These inductors must be able to pass currents in excess of 200 mA DC.
- Components R8, R9, R31, and R35 (see Figure 5) allow for external adjustment of the IF amplifier bias currents. Skyworks recommends that these resistors have a tolerance of $\pm 1\%$ to optimize performance consistency of the SKY73420-11. These resistors are optional for device operation, but the performance in Tables 6 and 7 is specified for the values of the RIF resistors (R31 and R35) as indicated in the Tables.

- Components R29, R33, R34, and R37 (see Figure 5) allow for external adjustment of the LO driver bias currents. Skyworks recommends that these resistors have a tolerance of ± 1 percent to optimize performance consistency of the SKY73420-11. These resistors are optional for device operation, but the performance in Tables 6 and 7 specified for the values of the RLO resistors (R29 and R37) as indicated in the Tables.
- It is recommended to apply solder paste with stencil, as noted in Figure 6.

Package Dimensions

The PCB layout footprint for the SKY73420-11 is provided in Figure 6. Figure 7 shows the package dimensions for the 36-pin QFN and Figure 8 provides the tape and reel dimensions.

Package and Handling Information

Since the device package is sensitive to moisture absorption, it is baked and vacuum packed before shipping. Instructions on the shipping container label regarding exposure to moisture after the container seal is broken must be followed. Otherwise, problems related to moisture absorption may occur when the part is subjected to high temperature during solder assembly.

The SKY73420-11 is rated to Moisture Sensitivity Level 3 (MSL3) at 260 °C. It can be used for lead or lead-free soldering. For additional information, refer to the Skyworks Application Note, *PCB Design & SMT Assembly/Rework Guidelines for MCM-L Packages*, document number 101752.

Care must be taken when attaching this product, whether it is done manually or in a production solder reflow environment. Production quantities of this product are shipped in a standard tape and reel format.

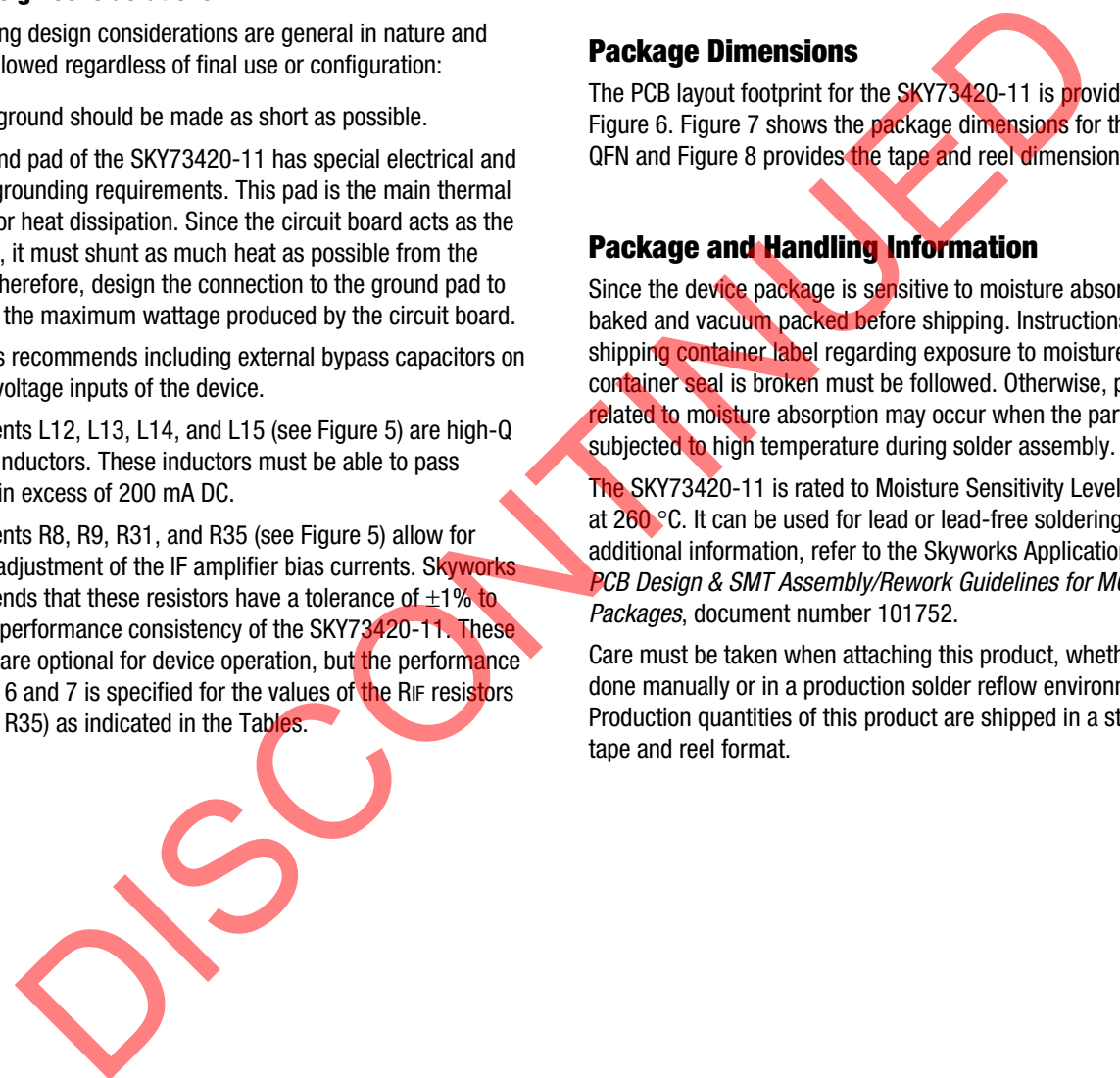

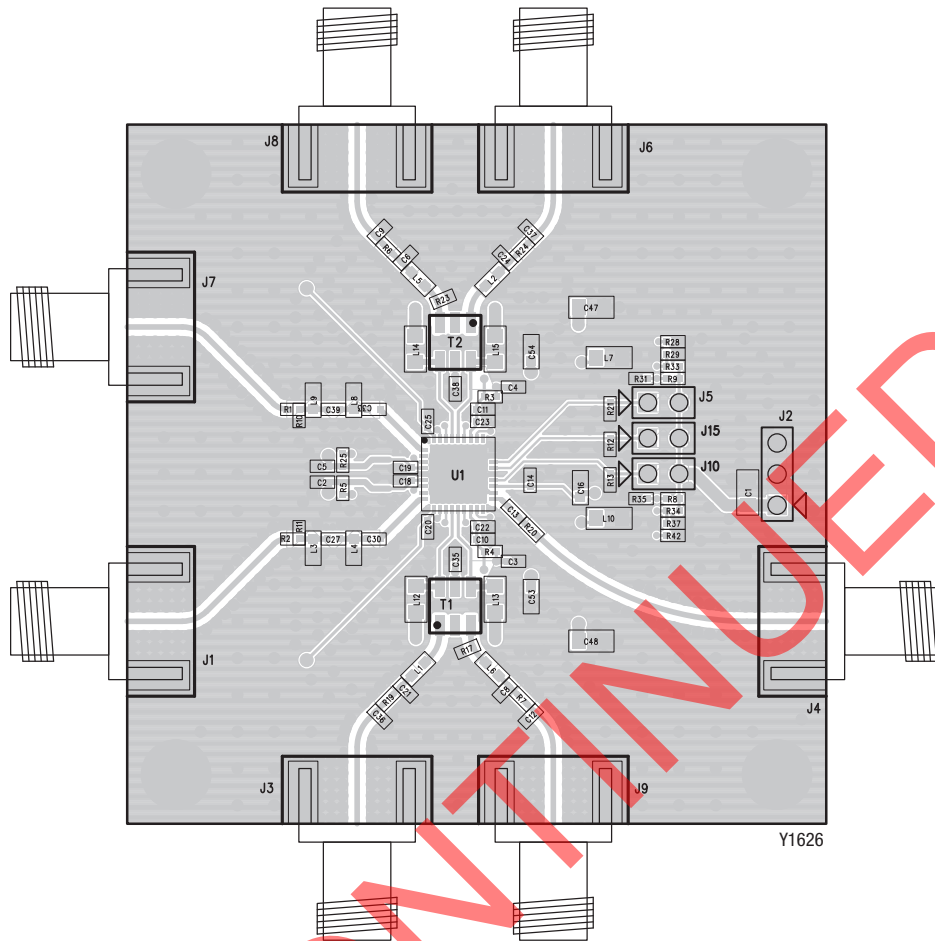
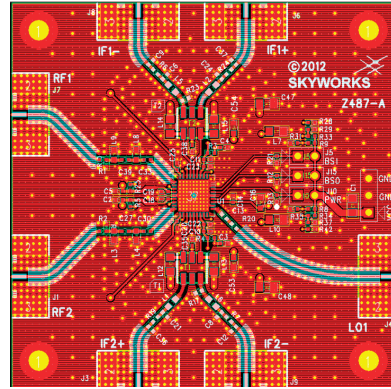
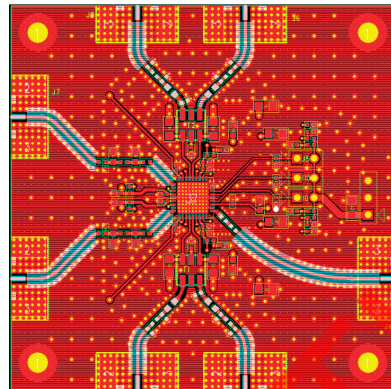

Figure 3. SKY73420-11 Evaluation Board Assembly Diagram

DISCONTINUED



Top Layer



Ground Plane

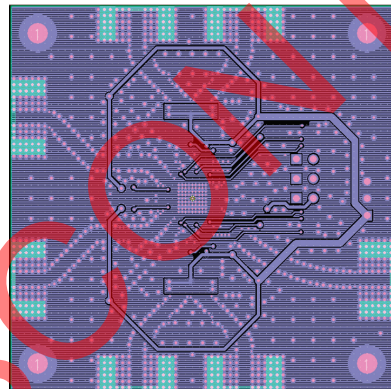

Power Plane

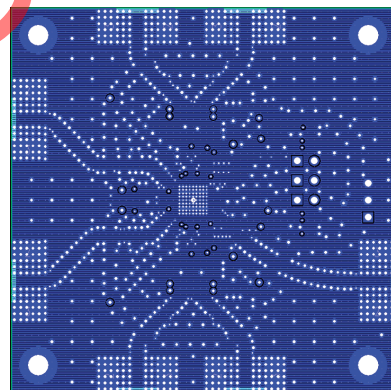

Bottom Layer

Y1627

Figure 4. SKY73420-11 Evaluation Board Layer Detail

DISCONTINUED

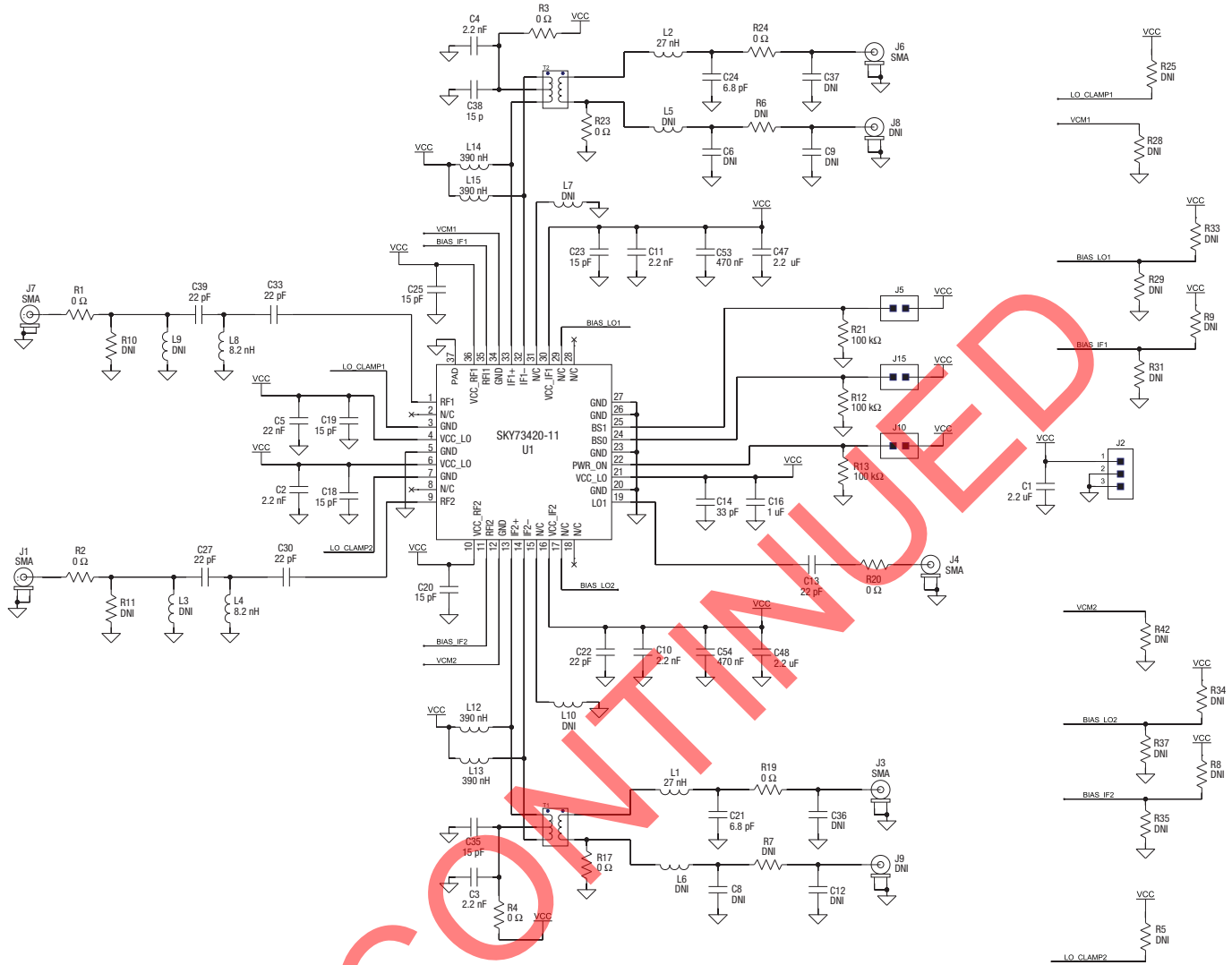

Figure 5. SKY73420-11 Evaluation Board Schematic

Y1636

Table 8. Evaluation Board Schematic Band-Dependent Components

RF Frequency Range (MHz)	3GPP Band	fIF (MHz)	Bandselects		RF Matching Comps		IF Matching Comps		IF Bias	LO Bias
			BS1	BS0	C33, C30 (pF)	C39, C27 (nH)	L2, L1 (nH)	C24, C21 (pF)	R31, R35 (kΩ)	R29, R37 (kΩ)
824 to 849	5	200	1	1	100	10	39	8.2	4.7	2.7
824 to 849	5	350	1	1	100	8.2	15	12	5.1	2.7
830 to 862	6, 19, 20	200	1	1	100	10	39	8.2	4.7	2.7
830 to 862	6, 19, 20	350	1	1	100	8.2	15	12	5.1	2.7
880 to 915	8	200	0	1	100	6.8	33		4.3	3.6
880 to 915	8	350	0	1	100	TBD	TBD	TBD	TBD	TBD
698 to 716	12, 17	200	1	1	100	15	33	6.8	5.1	2.4
698 to 716	12, 17	350	1	1	100	TBD	TBD	TBD	TBD	TBD
777 to 798	13, 14	200	1	1	100	8.2	33	6.8	4.7	3.0
777 to 798	13,14	350	1	1	100	TBD	TBD	TBD	TBD	TBD

DISCONTINUED

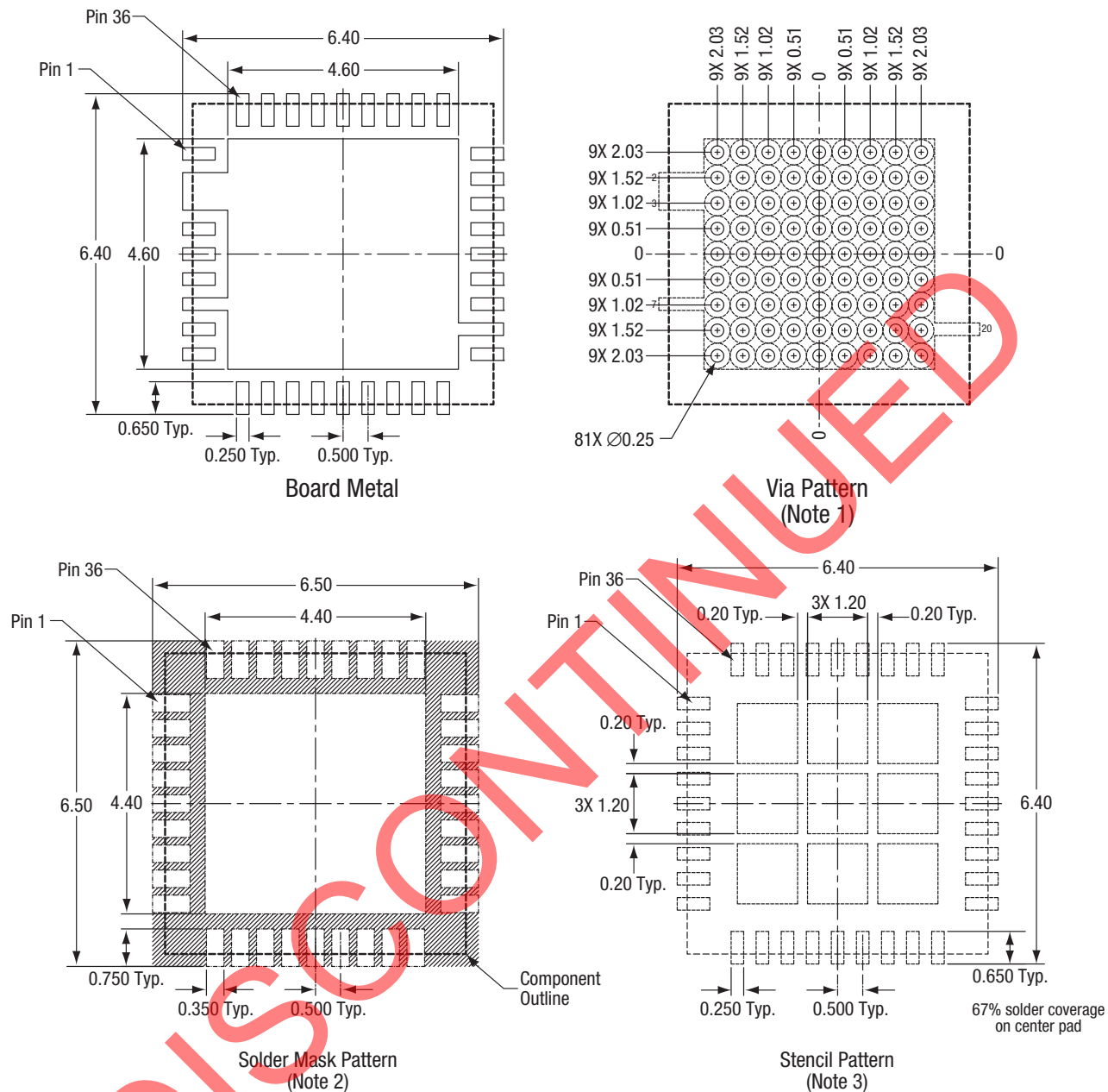

NOTES:

1. Via hole recommendations:
0.025 mm Cu via wall plating (minimum), soldermask on the far side should tent or plug via holes.
2. Soldermask recommendations:
Contact board fabricator for recommended soldermask offset and tolerance.
3. Stencil recommendations:
0.125 mm stencil thickness, laser cut apertures, trapezoidal walls and rounded corners offer better paste release.

Dimension and tolerancing according to ASME Y14.5M-1994.
Unless specified, dimensions are symmetrical about center lines.
All dimensions are in millimeters.

S3158

Figure 6. PCB Layout Footprint for the SKY73420-11 6 x 6 mm QFN

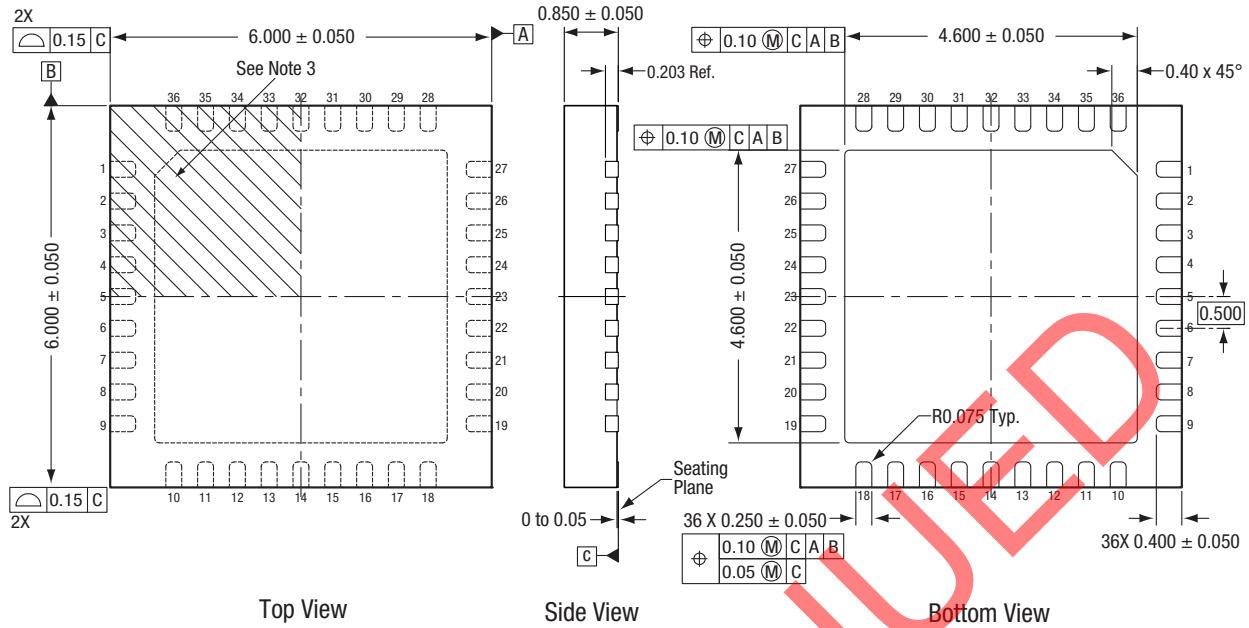

- NOTES:**
- All measurements are in millimeters.
 - Dimensioning and tolerancing according to ASME Y14.5M-1994. Unless otherwise specified the following values apply:
 Decimal Tolerance: Angular Tolerance:
 X.X (1 place) ± 0.1 mm ±1°
 X.XX (2 places) ± 0.05 mm
 X.XXX (3 places) ± 0.025 mm
 - Terminal #1 identification mark located within marked area.
 - Unless specified, dimensions are symmetrical about center lines.

S2944

Figure 7. SKY73420-11 36-Pin QFN Package Dimensions

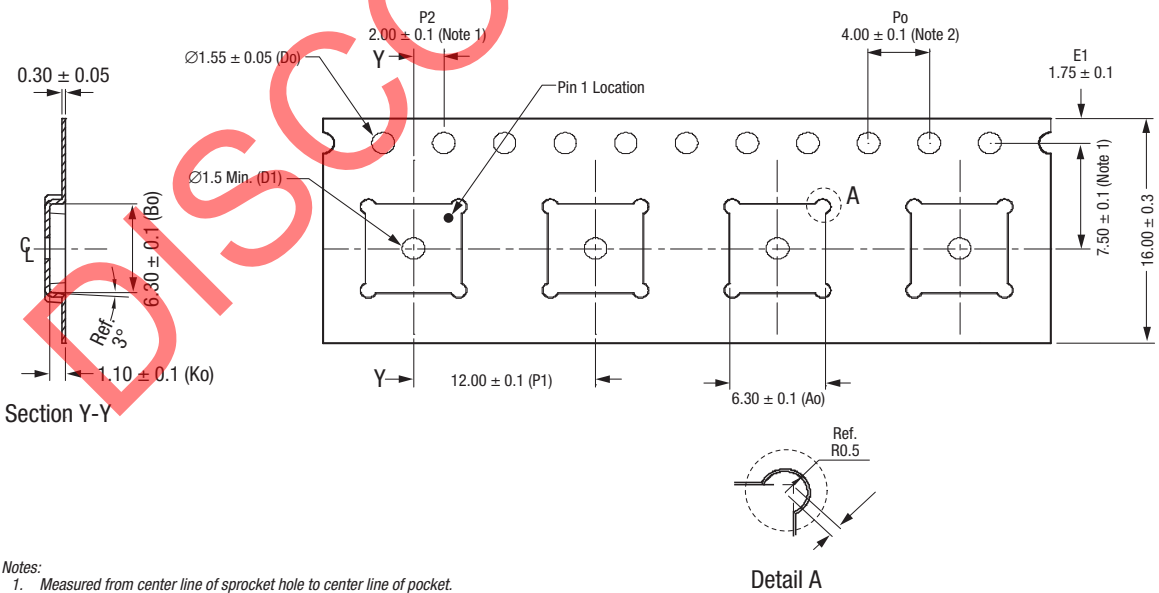

- Notes:**
- Measured from center line of sprocket hole to center line of pocket.
 - Cumulative tolerance of 10 sprocket holes is ± 0.20 mm.
 - Other material available.
- All measurements are in millimeters.

S2943

Figure 8. SKY73420-11 Tape and Reel Dimensions

Ordering Information

Model Name	Manufacturing Part Number	Evaluation Board Part Number
SKY73420-11: 650 to 950 MHz Downconversion Mixer	SKY73420-11	*** TBD ***



Copyright © 2013, 2015, 2019 Skyworks Solutions, Inc. All Rights Reserved.

Information in this document is provided in connection with Skyworks Solutions, Inc. (“Skyworks”) products or services. These materials, including the information contained herein, are provided by Skyworks as a service to its customers and may be used for informational purposes only by the customer. Skyworks assumes no responsibility for errors or omissions in these materials or the information contained herein. Skyworks may change its documentation, products, services, specifications or product descriptions at any time, without notice. Skyworks makes no commitment to update the materials or information and shall have no responsibility whatsoever for conflicts, incompatibilities, or other difficulties arising from any future changes.

No license, whether express, implied, by estoppel or otherwise, is granted to any intellectual property rights by this document. Skyworks assumes no liability for any materials, products or information provided hereunder, including the sale, distribution, reproduction or use of Skyworks products, information or materials, except as may be provided in Skyworks Terms and Conditions of Sale.

THE MATERIALS, PRODUCTS AND INFORMATION ARE PROVIDED “AS IS” WITHOUT WARRANTY OF ANY KIND, WHETHER EXPRESS, IMPLIED, STATUTORY, OR OTHERWISE, INCLUDING FITNESS FOR A PARTICULAR PURPOSE OR USE, MERCHANTABILITY, PERFORMANCE, QUALITY OR NON-INFRINGEMENT OF ANY INTELLECTUAL PROPERTY RIGHT; ALL SUCH WARRANTIES ARE HEREBY EXPRESSLY DISCLAIMED. SKYWORKS DOES NOT WARRANT THE ACCURACY OR COMPLETENESS OF THE INFORMATION, TEXT, GRAPHICS OR OTHER ITEMS CONTAINED WITHIN THESE MATERIALS. SKYWORKS SHALL NOT BE LIABLE FOR ANY DAMAGES, INCLUDING BUT NOT LIMITED TO ANY SPECIAL, INDIRECT, INCIDENTAL, STATUTORY, OR CONSEQUENTIAL DAMAGES, INCLUDING WITHOUT LIMITATION, LOST REVENUES OR LOST PROFITS THAT MAY RESULT FROM THE USE OF THE MATERIALS OR INFORMATION, WHETHER OR NOT THE RECIPIENT OF MATERIALS HAS BEEN ADVISED OF THE POSSIBILITY OF SUCH DAMAGE.

Skyworks products are not intended for use in medical, lifesaving or life-sustaining applications, or other equipment in which the failure of the Skyworks products could lead to personal injury, death, physical or environmental damage. Skyworks customers using or selling Skyworks products for use in such applications do so at their own risk and agree to fully indemnify Skyworks for any damages resulting from such improper use or sale.

Customers are responsible for their products and applications using Skyworks products, which may deviate from published specifications as a result of design defects, errors, or operation of products outside of published parameters or design specifications. Customers should include design and operating safeguards to minimize these and other risks. Skyworks assumes no liability for applications assistance, customer product design, or damage to any equipment resulting from the use of Skyworks products outside of stated published specifications or parameters.

Skyworks and the Skyworks symbol are trademarks or registered trademarks of Skyworks Solutions, Inc., in the United States and other countries. Third-party brands and names are for identification purposes only, and are the property of their respective owners. Additional information, including relevant terms and conditions, posted at www.skyworksinc.com, are incorporated by reference.

X-ON Electronics

Largest Supplier of Electrical and Electronic Components

Click to view similar products for [RF Mixer](#) category:

Click to view products by [Skyworks](#) manufacturer:

Other Similar products are found below :

[HMC337-SX](#) [HMC404-SX](#) [mamx-009646-23dbml](#) [HMC339-SX](#) [HMC8192-SX](#) [MIQ24MS-2](#) [HMC220BMS8GETR](#) [M85C](#) [HMC554A-SX](#)
[HMC8192LG](#) [HMC521A-SX](#) [HMC521ACHIPS](#) [CMD258C4](#) [LT5511EFE](#) [MAMX-011023-SMB](#) [HMC399MS8TR](#) [HMC333TR](#)
[HMC214MS8TR](#) [HMC175MS8TR](#) [MAMXSS0012TR-3000](#) [109728-HMC129LC4](#) [CSM1-13](#) [SA612AD/01.112](#) [HMC785LP4ETR](#)
[LT5579IUH#PBF](#) [HMC773ALC3BTR](#) [HMC558ALC3B](#) [HMC329ALC3B](#) [MY63H](#) [AD8343ARUZ-REEL7](#) [AD608AR](#) [AD608ARZ](#)
[AD831APZ](#) [AD831APZ-REEL7](#) [AD8342ACPZ-REEL7](#) [AD8343ARUZ](#) [AD8344ACPZ-REEL7](#) [ADL5350ACPZ-R7](#) [ADL5363ACPZ-R7](#)
[ADL5365ACPZ-R7](#) [ADL5801ACPZ-R7](#) [ADL5802ACPZ-R7](#) [HMC1056LP4BE](#) [HMC1057-SX](#) [HMC1063LP3E](#) [HMC1093-SX](#) [HMC1106-](#)
[SX](#) [HMC129](#) [HMC143](#) [HMC400MS8ETR](#)