

Schottky Barrier Rectifiers

Features

- Low Forward Voltage Drop
- Fast Switching Time
- Surface Mount Package Ideally
Suited for Automated Insertion
- Lead, Halogen and Antimony Free,
RoHS Compliant "Green" Device

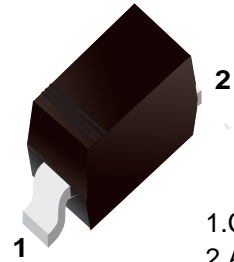

■ Simplified outline(SOD-323)



Marking

Type number	Marking code
1SS357	S31

Maximum Ratings and Electrical characteristics

Ratings at 25 °C ambient temperature unless otherwise specified.

Parameter	Symbols	1SS357	Units
Peak reverse Voltage	V_{RM}	45	V
DC Blocking Voltage	V_R	40	V
Forward Continuous Current	I_F	100	mA
Non-Repetitive Peak Forward Surge Current @t = 8.3ms	I_{FSM}	1	A
Power dissipation	P_D	200	mW
Forward Voltage	V_F	0.35(Max) 0.45(Max) 0.60(Max)	V
Peak Reverse Current	I_R	5(Max)	uA
Typical Junction Capacitance	C_T	25(Max)	pF
Thermal Resistance, Junction to Ambient Air (NOTE 1)	$R_{\theta JA}$	500	°C/W
Junction Temperature	T_j	125	°C
Storage Temperature	T_{stg}	-55 ~ +150	°C

Notes: 1. Part mounted on FR-4 board with recommended pad layout.

Fig.1 Power Derating Curve

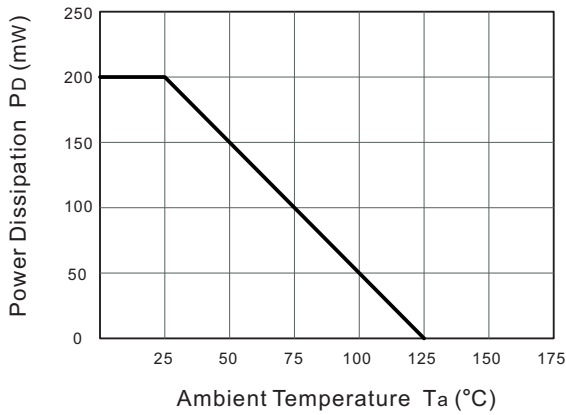

Fig.2 Typical Instantaneous Reverse Characteristics

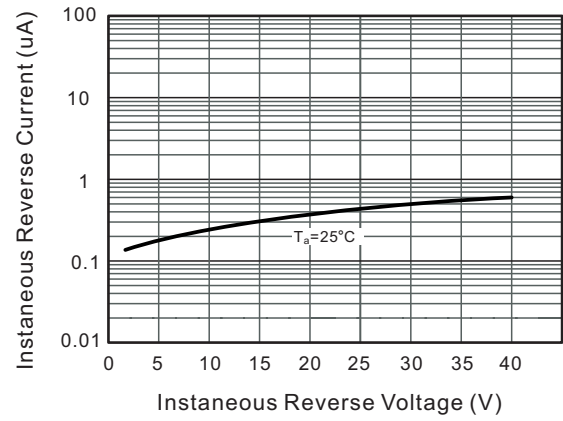

Fig.3 Typical Forward Characteristic

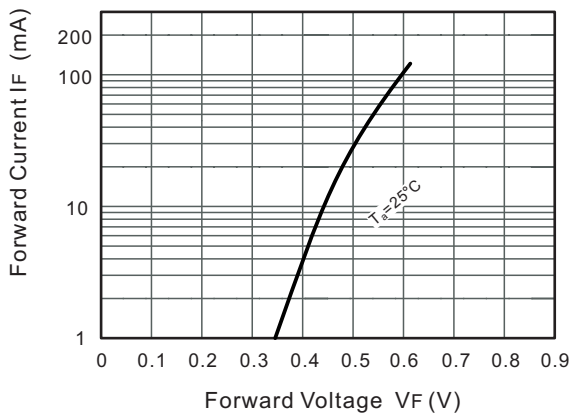
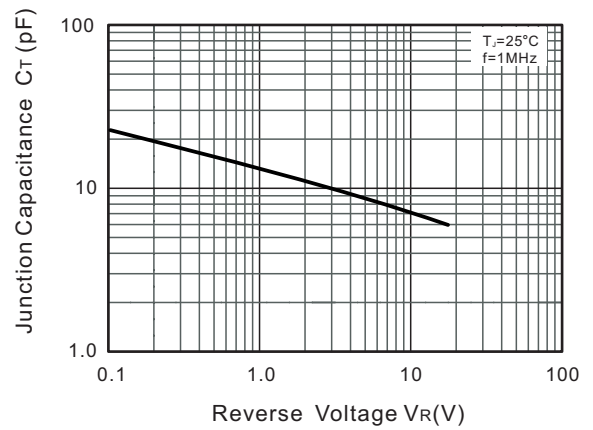
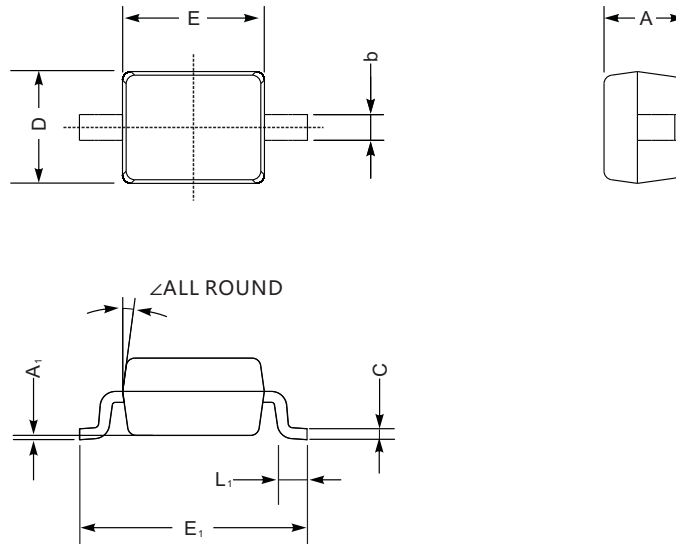

Fig.4 Typical Junction Capacitance



■ SOD-323



SOD-323 mechanical data

UNIT		A	C	D	E	E ₁	b	L ₁	A ₁	∠
mm	max	1.1	0.15	1.4	1.8	2.75	0.4	0.45	0.2	9°
	min	0.8	0.08	1.2	1.4	2.55	0.25	0.2	—	
mil	max	43	5.9	55	70	108	16	16	8	
	min	32	3.1	47	63	100	9.8	7.9	—	

■ The recommended mounting pad size

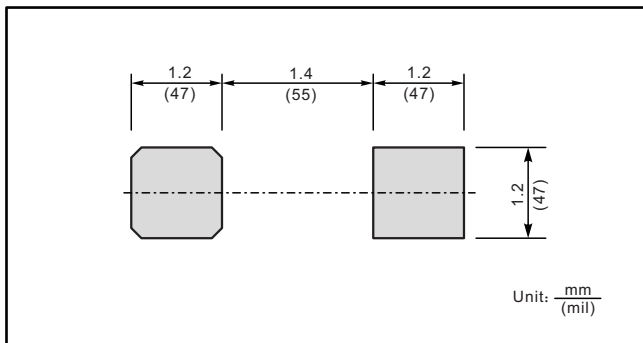

X-ON Electronics

Largest Supplier of Electrical and Electronic Components

Click to view similar products for [Schottky Diodes & Rectifiers](#) category:

Click to view products by [SLKORMICRO](#) manufacturer:

Other Similar products are found below :

[MA4E2039](#) [MA4E2508M-1112](#) [MBR1545CT](#) [MMBD301M3T5G](#) [RB160M-50TR](#) [D83C](#) [BAS16E6433HTMA1](#) [BAT 54-02LRH E6327](#)
[NRVBAF360T3G](#) [NSR05F40QNXT5G](#) [NTE555](#) [JANS1N6640](#) [SK310-T](#) [SK34B-TP](#) [SS3003CH-TL-E](#) [GA01SHT18](#)
[CRS10I30A\(TE85L,QM](#) [MA4E2501L-1290](#) [MBRA140TRPBF](#) [MBRB30H30CT-1G](#) [BAT 15-04R E6152](#) [JANTX1N5712-1](#) [DMJ3940-000](#)
[SB007-03C-TB-E](#) [SK33B-TP](#) [NRVBB20100CTT4G](#) [NRVBM120LT1G](#) [NTSB30U100CT-1G](#) [VS-6CWQ10FNHM3](#) [CRG04\(T5L,TEMQ\)](#)
[ACDBA1100LR-HF](#) [ACDBA1200-HF](#) [ACDBA240-HF](#) [ACDBA3100-HF](#) [CDBQC0530L-HF](#) [CDBQC0240LR-HF](#) [ACDBA260LR-HF](#)
[ACDBA1100-HF](#) [MA4E2502L-1246](#) [10BQ015-M3/5BT](#) [NRVBM120ET1G](#) [CRS08TE85LQM](#) [PMAD1108-LF](#) [B120Q-13-F](#) [1N5819T-G](#)
[B0530WSQ-7-F](#) [PDS1040Q-13](#) [B160BQ-13-F](#) [SDM05U20CSP-7](#) [B140S1F-7](#)