

FEATURES

- Ultra small plastic SMD package.
- High switching speed: max.4ns.
- Continuous reverse voltage: max.75V.
- Repetitive peak reverse voltage: max.85V
- Repetitive peak forward current: max.500mA

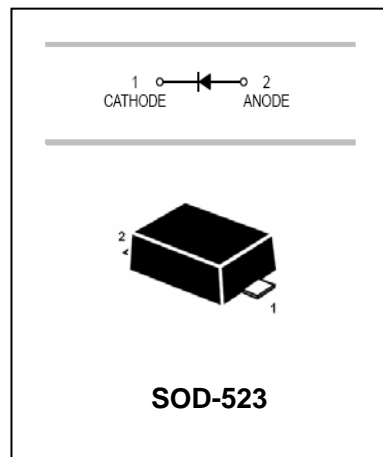

APPLICATIONS

- High-speed switching in surface mounted circuits.

ORDERING INFORMATION

Type No.	Marking	Package Code
BAS516	61	SOD-523

MAXIMUM RATING @ Ta=25°C unless otherwise specified

Parameter	Symbol	Limits	Unit
Repetitive peak reverse voltage	V_{RRM}	85	V
Continuous reverse voltage	V_R	75	V
Continuous forward current	I_F	250	mA
Repetitive forward current	I_{FRM}	500	mA
Non-repetitive peak forward surge current t=1μs t=1ms t=1s	I_{FSM}	4 1 0.5	A
Total power dissipation	P_{tot}	500	mW
Junction temperature	T_j	150	°C
Storage temperature	T_{stg}	-65 to +150	°C

ELECTRICAL CHARACTERISTICS @ Ta=25°C unless otherwise specified

Parameter	Symbol	Min.	Max.	Unit	Conditions
Forward voltage	V_F		0.715	V	$I_F=1\text{mA}$
			0.855	V	$I_F=10\text{mA}$
			1	V	$I_F=50\text{mA}$
			1.25	V	$I_F=150\text{mA}$
Reverse current	I_R		30	nA	$V_R=25\text{V}$
			30	μA	$V_R=25\text{V } T_J=150^\circ\text{C}$
Diode capacitance	C_d		1	pF	$V_R=0, f=1\text{MHz}$
			1	pF	$V_R=0, f=1\text{MHz}$
Reverse recovery time	t_{rr}		4	ns	$I_F=10\text{mA}, I_R=10\text{mA}, R_L=400\Omega$

TYPICAL CHARACTERISTICS @ Ta=25°C unless otherwise specified

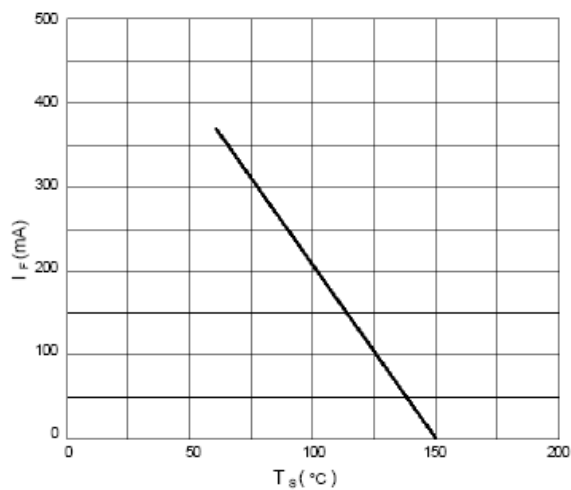

Fig.1 Maximum permissible continuous forward current as a function of soldering point temperature.

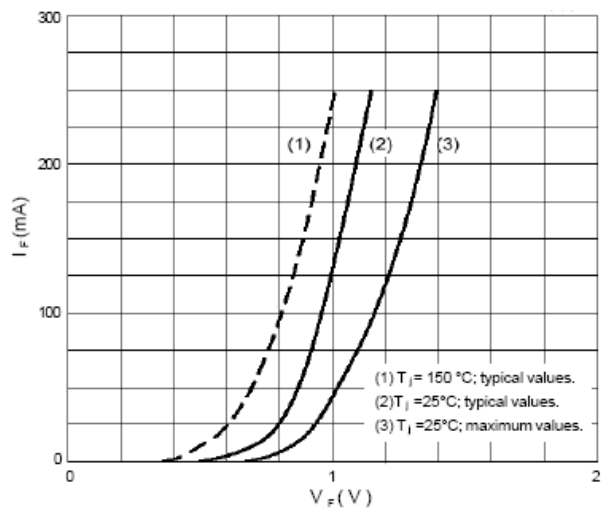

Fig.2 Forward current as a function of forward voltage.

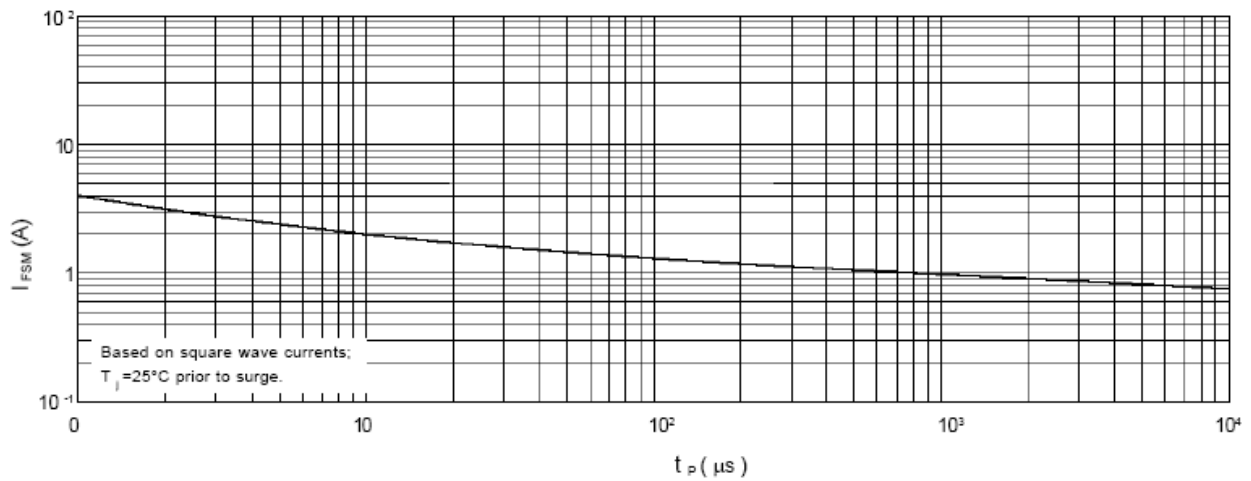

Fig.3 Maximum permissible non-repetitive peak forward current as a function of pulse duration.

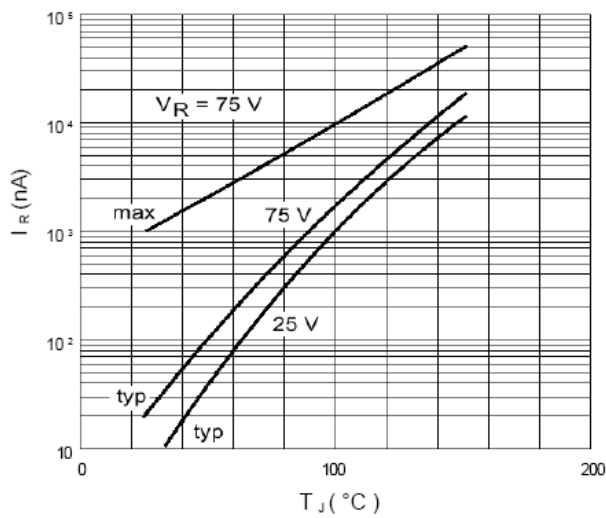

Fig.4 Reverse current as a function of junction temperature.

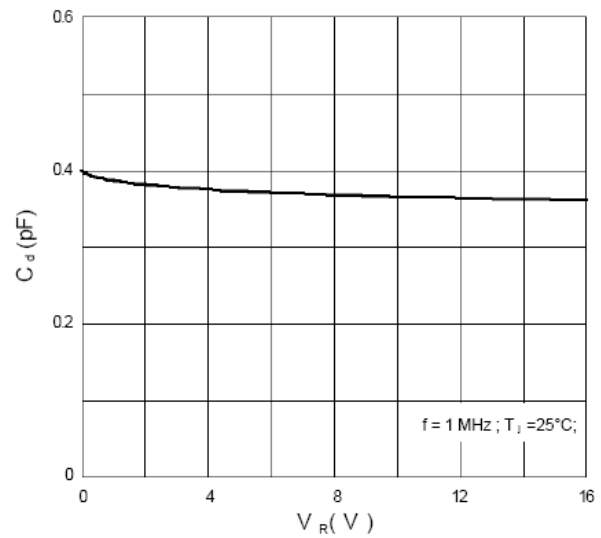
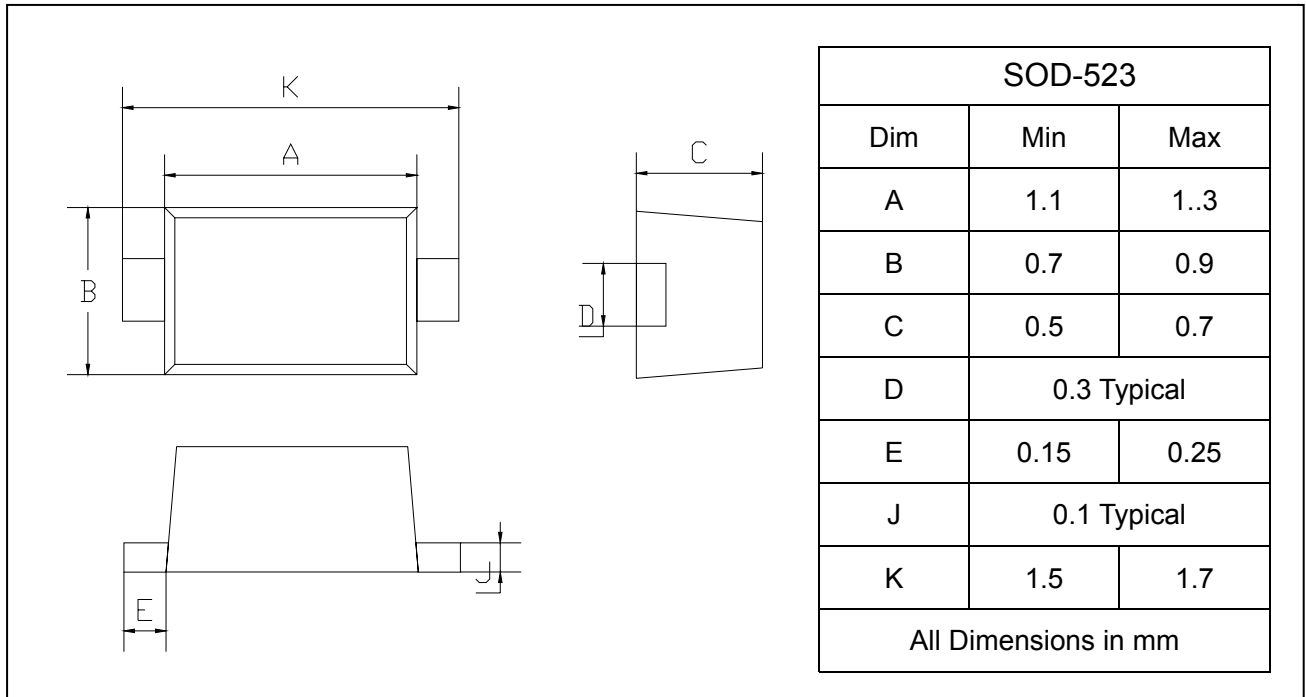

Fig.5 Diode capacitance as a function of reverse voltage; typical values.

PACKAGE OUTLINE

Plastic surface mounted package

SOD-523



SOLDERING FOOTPRINT

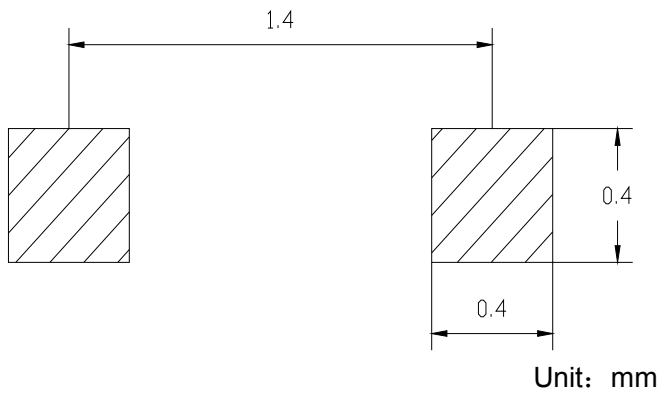

PACKAGE INFORMATION

Device	Package	Shipping
BAS516	SOD-523	3000/Tape&Reel

X-ON Electronics

Largest Supplier of Electrical and Electronic Components

Click to view similar products for [Diodes - General Purpose, Power, Switching category](#):

Click to view products by [SLKORMICRO manufacturer](#):

Other Similar products are found below :

[MMBD3004S-13-F](#) [1N3611](#) [NTE156A](#) [NTE6244](#) [1SS400CST2RA](#) [SDAA13](#) [SHN2D02FUTW1T1G](#) [1N4449](#) [1N456A](#) [1N914BTR](#)
[D291S45T](#) [BAS 16-02L E6327](#) [BAS 16-02V H6327](#) [BAS 21U E6327](#) [BAS 28 E6327](#) [BAW56DWQ-7-F](#) [BAW56M3T5G](#) [BAW75-TAP](#)
[MM230L-CAA](#) [IDW40E65D1](#) [JAN1N3600](#) [JAN1N4454UR-1](#) [SMMSD4148T3G](#) [BYW95B/A52A](#) [NSVDAN222T1G](#) [CDSZC01100-HF](#)
[BAV70HDW-7](#) [BAS28-7](#) [JANTX1N6640](#) [BAW56HDW-13](#) [BAS28 TR](#) [VS-HFA04SD60STR-M3](#) [1SS388-TP](#) [BAV99TQ-13-F](#)
[BAV99HDW-13](#) [1N4004](#) [MMDB30-E28X](#) [LS4148](#) [IDV15E65D2](#) [W0503RH200S0L](#) [M0268SJ200NLF](#) [M0268RJ200NLF](#) [S3MBF](#) [US1J](#)
[DAN217U-TP](#) [SHV-06JNS-Q](#) [IDW30C65D1](#) [IDW80C65D1](#) [VS-HFA30TA60CSR-M3](#) [M1MA152WAT1](#)