

NPN Silicon AF Transistors

FEATURES

- For AF driver and output stages
- High collector current
- Low collector-emitter saturation voltage
- Complementary types: BCX51...BCX53(PNP)

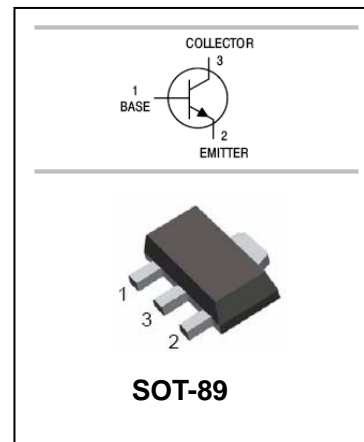

ORDERING INFORMATION

Type No.	Marking	Package Code
BCX54	BA	SOT-89
BCX54-10	BC	SOT-89
BCX54-16	BD	SOT-89
BCX55	BE	SOT-89
BCX55-10	BG	SOT-89
BCX55-16	BM	SOT-89
BCX56	BH	SOT-89
BCX56-10	BK	SOT-89
BCX56-16	BL	SOT-89

MAXIMUM RATING @ Ta=25°C unless otherwise specified

Symbol	Parameter	Value	Unit
V_{CBO}	Collector-Base Voltage	BCX54	45
		BCX55	60
		BCX56	100
V_{CEO}	Collector-Emitter Voltage	BCX54	45
		BCX55	60
		BCX56	80
V_{EBO}	Emitter-Base Voltage	5	V
I_C	DC Collector Current	1	A
I_{CM}	Peak Collector Current	1.5	A
I_B	Base current	100	mA
I_{BM}	Peak base current	200	mA
P_{tot}	Total power dissipation, $T_S=130^\circ\text{C}$	500	mW
T_j, T_{stg}	Junction and Storage Temperature	-65 to +150	°C

ELECTRICAL CHARACTERISTICS @ Ta=25°C unless otherwise specified

Parameter	Symbol	Test conditions	MIN	MAX	UNIT
Collector-base breakdown voltage	$V_{(BR)CBO}$	$I_C=100\mu A$ $I_B=0$ BCX54 BCX55 BCX56	45 60 100		V
Collector-emitter breakdown voltage	$V_{(BR)CEO}$	$I_C=10mA$ $I_B=0$ BCX54 BCX55 BCX56	45 60 80		V
Emitter-base breakdown voltage	$V_{(BR)EBO}$	$I_E=10\mu A$ $I_C=0$	5		V
Collector cut-off current	I_{CBO}	$V_{CB}=30V$ $I_E=0$		100	nA
		$V_{CB}=30V$ $I_E=0$, $T_A=150^\circ C$		20	μA
DC current gain	h_{FE}	$V_{CE}=2V$ $I_C=5mA$	25		
		$V_{CE}=2V$ $I_C=150mA$ BCX54...56	40	250	
		$V_{CE}=2V$ $I_C=150mA$ -10 -16	63 100	160 250	
		$V_{CE}=2V$ $I_C=500mA$	25		
Collector-emitter saturation voltage	$V_{CE(sat)}$	$I_C=500mA$ $I_B=50mA$		0.5	V
Base-emitter voltage	V_{BE}	$I_C=500mA$, $V_{CE}=2V$		1	V
Transition frequency	f_T	$V_{CE}=10V$, $I_C=50mA$, $f=20MHz$	100		MHz

TYPICAL CHARACTERISTICS @ $T_a=25^\circ\text{C}$ unless otherwise specified

Total power dissipation $P_{\text{tot}} = f(T_S)$

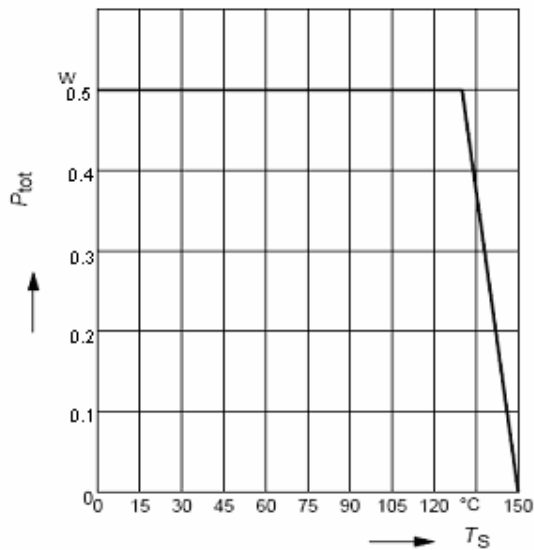

Transition frequency $f_T = f(I_C)$

$V_{CE} = 10\text{V}$

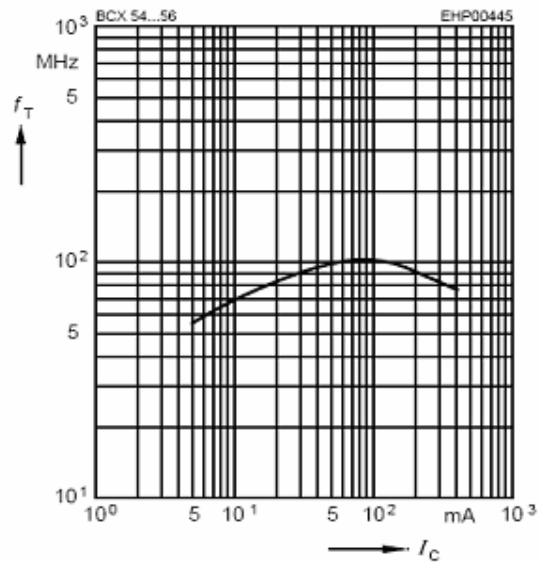

Collector current $I_C = f(V_{BE})$

$V_{CE} = 2\text{V}$

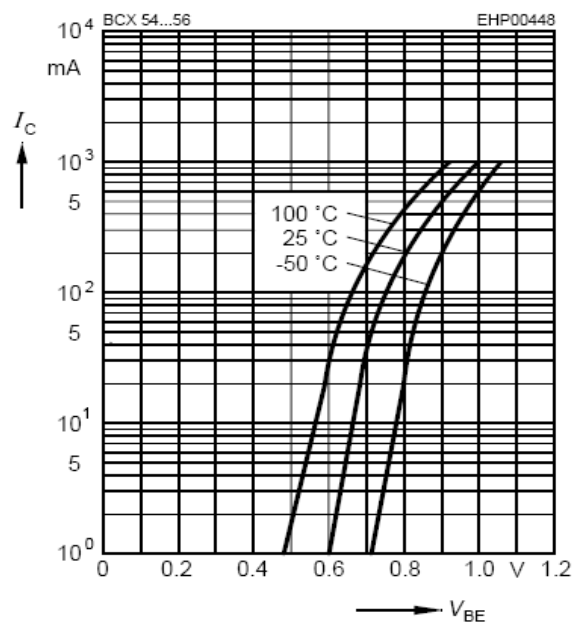

Collector-emitter saturation voltage

$I_C = f(V_{CE\text{sat}}), h_{FE} = 10$

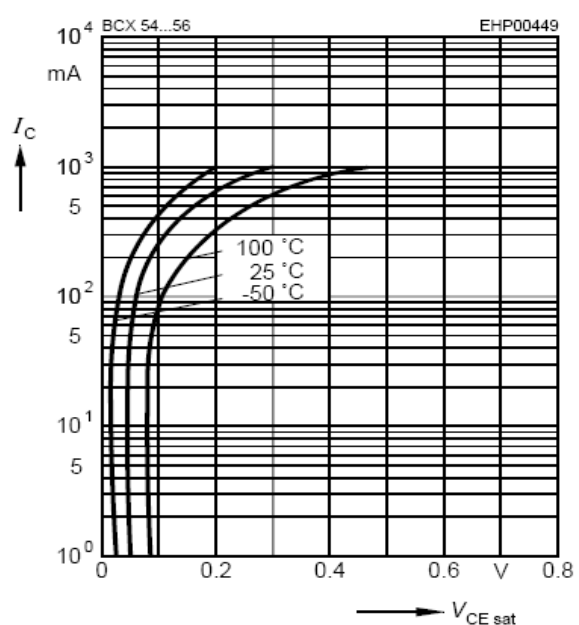

Base-emitter saturation voltage

$$I_C = f(V_{BEsat}), h_{FE} = 10$$

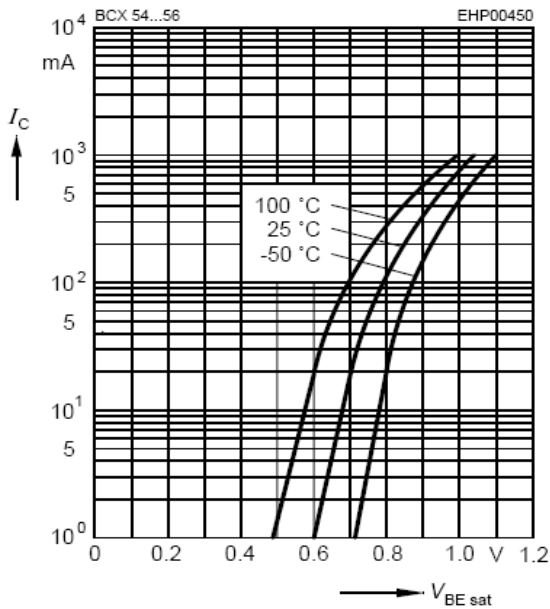

DC current gain $h_{FE} = f(I_C)$

$$V_{CE} = 2V$$

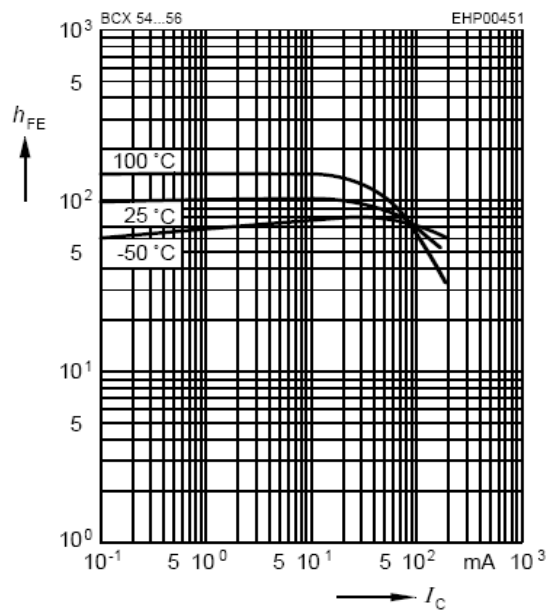

Collector cutoff current $I_{CBO} = f(T_A)$

$$V_{CB} = 30V$$

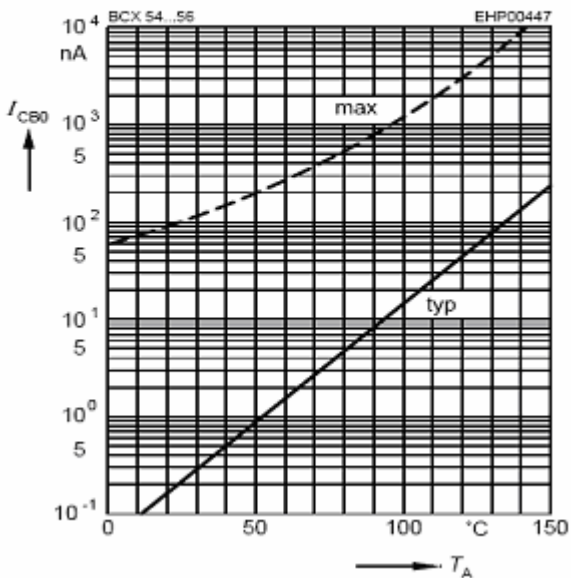

PACKAGE OUTLINE

Plastic surface mounted package

SOT-89

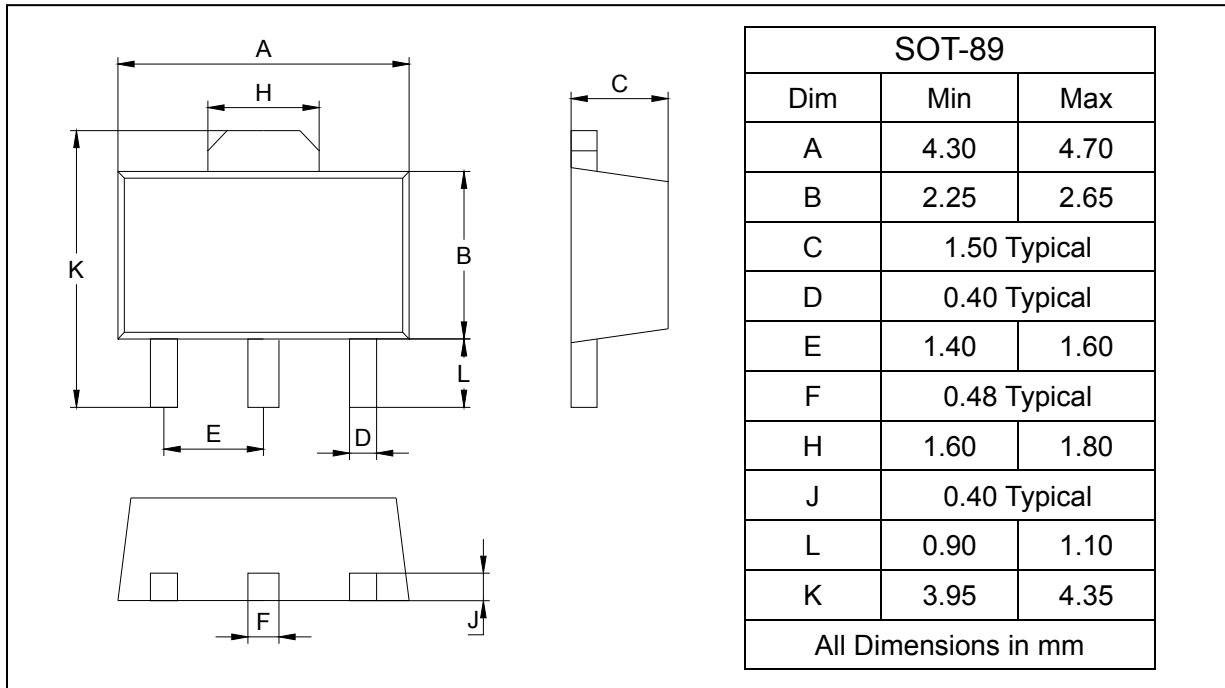

SOLDERING FOOTPRINT

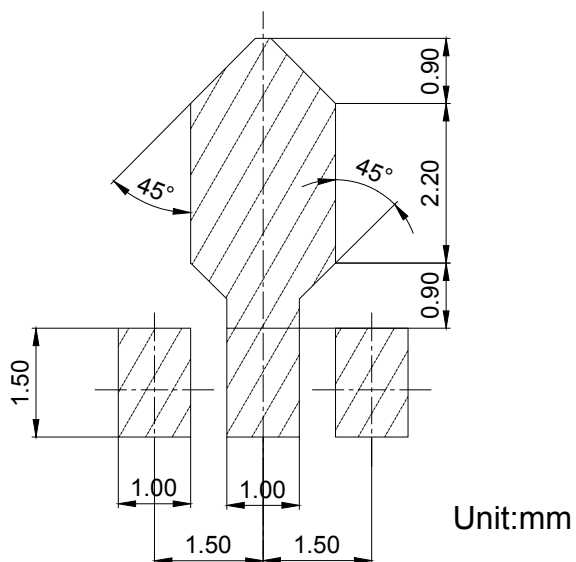

PACKAGE INFORMATION

Device	Package	Shipping
BCX54/BCX55/BCX56	SOT-89	1000/Tape&Reel

X-ON Electronics

Largest Supplier of Electrical and Electronic Components

Click to view similar products for [Bipolar Transistors - BJT category](#):

Click to view products by [SLKORMICRO manufacturer](#):

Other Similar products are found below :

[BC559C](#) [MCH4017-TL-H](#) [MMBT-2369-TR](#) [BC546/116](#) [NJVMJD148T4G](#) [NTE16](#) [NTE195A](#) [IMX9T110](#) [2N4401-A](#) [2N6728](#) [2SA1419T-TD-H](#) [2SB1204S-TL-E](#) [2SC5488A-TL-H](#) [FMC5AT148](#) [2N2369ADCSM](#) [2N2907A](#) [2N3904-NS](#) [2N5769](#) [2SC4618TLN](#) [CPH6501-TL-E](#) [US6T6TR](#) [BAX18/A52R](#) [BC556/112](#) [IMZ2AT108](#) [MMST8098T146](#) [MCH6102-TL-E](#) [BC846B-13-F](#) [2N3879](#) [30A02MH-TL-E](#) [NTE13](#) [NTE282](#) [NTE323](#) [NTE350](#) [NTE81](#) [JANTX2N2920L](#) [JANSR2N2907AUB](#) [CMLT3946EG TR](#) [SNSS40600CF8T1G](#) [CMLT3906EG TR](#) [GRP-DATA-JANS2N2907AUB](#) [GRP-DATA-JANS2N2222AUA](#) [MMDT3946FL3-7](#) [2N4240](#) [JANS2N3019](#) [MSB30KH-13](#) [2N2221AUB](#) [2SD1815T-TL-E](#) [2N6678](#) [2N2907Ae4](#) [JAN2N3507](#)