

LOW POWER DUAL VOLTAGE COMPARATORS

- WIDE SINGLE SUPPLY VOLTAGE RANGE OR DUAL SUPPLIES +2V TO +36V OR ±1V TO ±18V
- VERY LOW SUPPLY CURRENT (0.4mA) INDEPENDENT OF SUPPLY VOLTAGE (1mW/comparator at +5V)
- LOW INPUT BIAS CURRENT: 25nA TYP
- LOW INPUT OFFSET CURRENT: ±5nA TYP
- INPUT COMMON-MODE VOLTAGE RANGE INCLUDES GROUND
- LOW OUTPUT SATURATION VOLTAGE: 250mV TYP. ($I_O = 4mA$)
- DIFFERENTIAL INPUT VOLTAGE RANGE EQUAL TO THE SUPPLY VOLTAGE
- TTL, DTL, ECL, MOS, CMOS COMPATIBLE OUTPUTS

DESCRIPTION

This device consists of two independent low power voltage comparators designed specifically to operate from a single supply over a wide range of voltages. Operation from split power supplies is also possible.

These comparators also have a unique characteristic in that the input common-mode voltage range includes ground even though operated from a single power supply voltage.

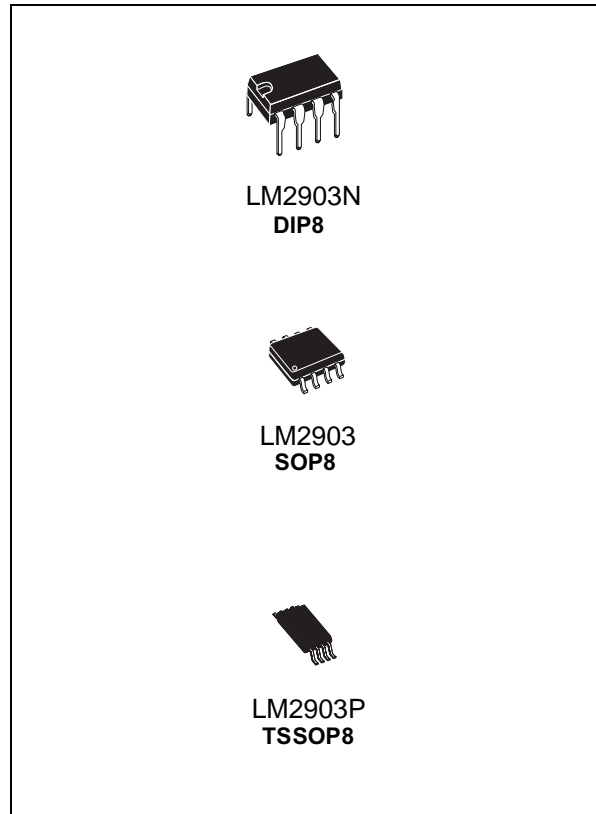

PIN CONNECTIONS (top view)

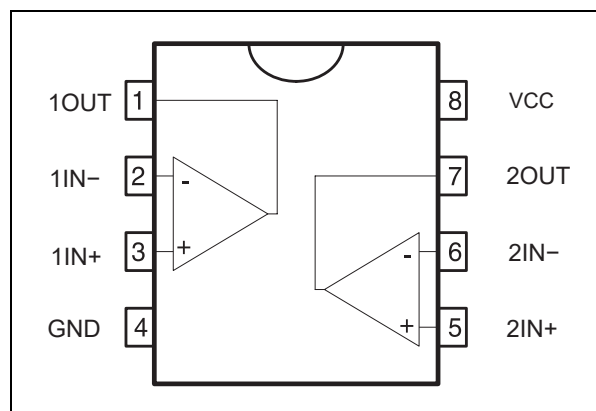

SCHEMATIC DIAGRAM (1/2 LM2903)

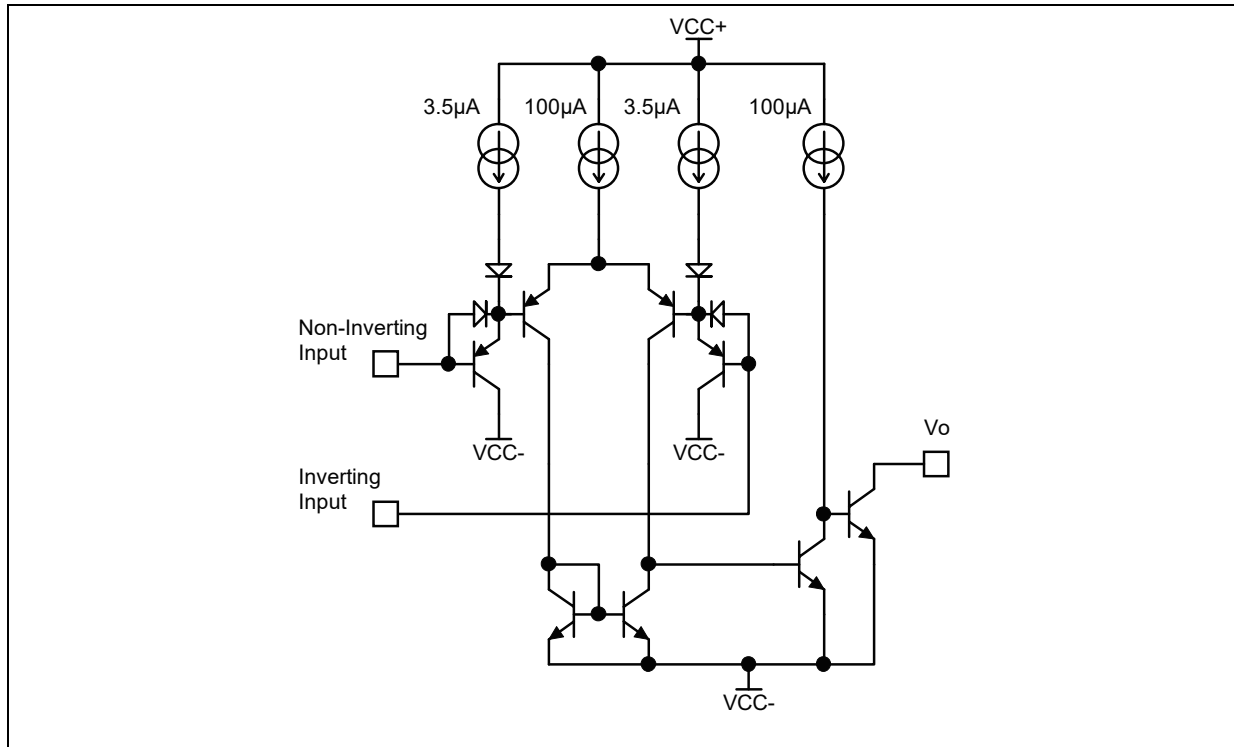

ABSOLUTE MAXIMUM RATINGS

Symbol	Parameter	Value	Unit	
V_{CC}	Supply Voltage	± 18 to 36	V	
V_{ID}	Differential Input Voltage	± 36	V	
V_I	Input Voltage	-0.3 to +36	V	
	Output Short-circuit to Ground ¹⁾	Infinite		
P_d	Power Dissipation ²⁾	DIP8 SO8 TSSOP8	1250 710 625	mW
$T_{Junction}$	Junction Temperature	+150	°C	
T_{stg}	Storage Temperature Range	-65 to +150	°C	

- Short-circuit from the output to V_{CC}^+ can cause excessive heating and eventual destruction. The maximum output current is approximately 20mA, independent of the magnitude of V_{CC}^+ .
- P_d is calculated with $T_{amb} = +25^\circ\text{C}$, $T_j = +150^\circ\text{C}$ and $R_{thja} = 100^\circ\text{C/W}$ for DIP8 package
 $= 175^\circ\text{C/W}$ for SO8 package
 $= 200^\circ\text{C/W}$ for TSSOP8 package

OPERATING CONDITIONS

Symbol	Parameter	Value	Unit
V_{icm}	Common Mode Input Voltage Range	0 to $V_{CC}^+ - 1.5$	V
T_{oper}	Operating Free-Air Temperature range	-40 to +125	°C

ELECTRICAL CHARACTERISTICS
 $V_{CC}^+ = 5V, V_{CC}^- = GND, T_{amb} = 25^\circ C$ (unless otherwise specified)

Symbol	Parameter	Min.	Typ.	Max.	Unit
V_{IO}	Input Offset Voltage ¹⁾ $T_{amb} = +25^\circ C$ $T_{min} \leq T_{amb} \leq T_{max}$.		1	7 15	mV
I_{IO}	Input Offset Current $T_{amb} = +25^\circ C$ $T_{min} \leq T_{amb} \leq T_{max}$.		5	50 150	nA
I_{IB}	Input Bias Current ²⁾ $T_{amb} = +25^\circ C$ $T_{min} \leq T_{amb} \leq T_{max}$.		25	250 400	nA
A_{VD}	Large Signal Voltage Gain ($V_{CC} = 15V, R_L = 15k\Omega, V_o = 1$ to $11V$)	25	200		V/mV
I_{CC}	Supply Current (all comparators) $V_{CC} = 5V$, no load $V_{CC} = 30V$, no load		0.4 1	1 2.5	mA
V_{ICM}	Input Common Mode Voltage Range ($V_{CC} = 30V$) ³⁾ $T_{amb} = +25^\circ C$ $T_{min} \leq T_{amb} \leq T_{max}$.	0 0		$V_{CC}^+ - 1.5$ $V_{CC}^+ - 2$	V
V_{ID}	Differential Input Voltage ⁴⁾			V_{CC}^+	V
V_{OL}	Low Level Output Voltage ($V_{id} = -1V, I_{sink} = 4mA$) $T_{amb} = +25^\circ C$ $T_{min} \leq T_{amb} \leq T_{max}$		250	400 700	mV
I_{OH}	High Level Output Current ($V_{CC} = V_o = 30V, V_{id} = 1V$) $T_{amb} = +25^\circ C$ $T_{min} \leq T_{amb} \leq T_{max}$		0.1	1	nA μA
I_{SINK}	Output Sink Current ($V_{id} = -1V, V_o = 1.5V$)	6	16		mA
t_{RE}	Small Signal Response Time ⁵⁾ ($R_L = 5.1k\Omega$ to V_{CC}^+)		1.3		μs
t_{REL}	Large Signal Response Time ⁶⁾ TTL Input ($V_{ref} = +1.4V, R_L = 5.1k\Omega$ to V_{CC}^+) Output Signal at 50% of final value Output Signal at 95 % of final value			500 1	ns μs

- At output switch point, $V_o = 1.4V, R_S = 0\Omega$ with V_{CC}^+ from 5V to 30V, and over the full input common-mode range (0V to $V_{CC}^+ - 1.5V$).
- The direction of the input current is out of the IC due to the PNP input stage. This current is essentially constant, independent of the state of the output, so no loading charge exists on the reference of input lines
- The input common-mode voltage of either input signal voltage should not be allowed to go negative by more than 0.3V. The upper end of the common-mode voltage range is $V_{CC}^+ - 1.5V$, but either or both inputs can go to +30V without damage.
- Positive excursions of input voltage may exceed the power supply level. As long as the other voltage remains within the common-mode range, the comparator will provide a proper output state.
The low input voltage state must not be less than $-0.3V$ (or $0.3V$ below the negative power supply, if used)
- The response time specified is for a 100mV input step with 5mV overdrive.
- Maximum values are guaranteed by design & evaluation.

SUPPLY CURRENT versus SUPPLY VOLTAGE

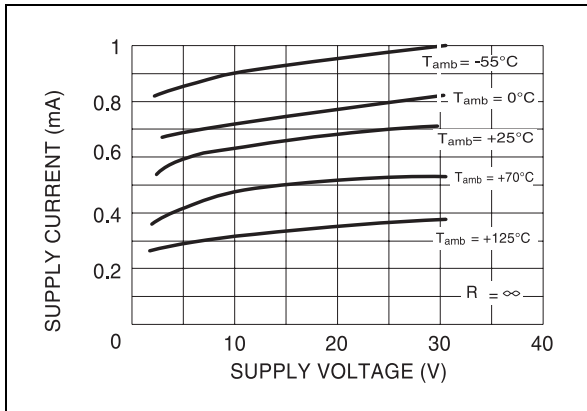

RESPONSE TIME FOR VARIOUS INPUT OVERDRIVES - NEGATIVE TRANSITION

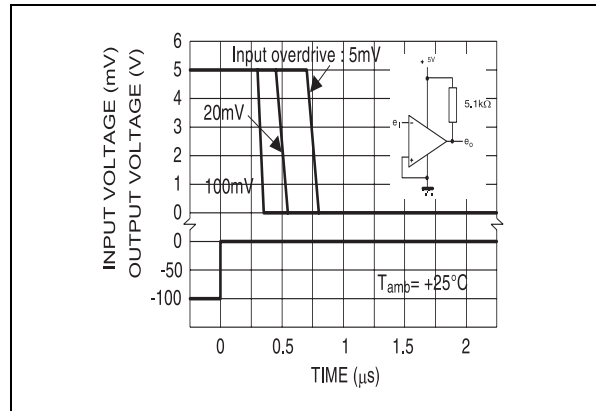

INPUT CURRENT versus SUPPLY VOLTAGE

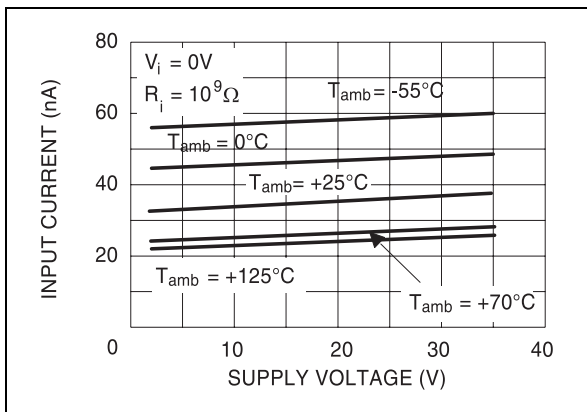

RESPONSE TIME FOR VARIOUS INPUT OVERDRIVES - POSITIVE TRANSITION

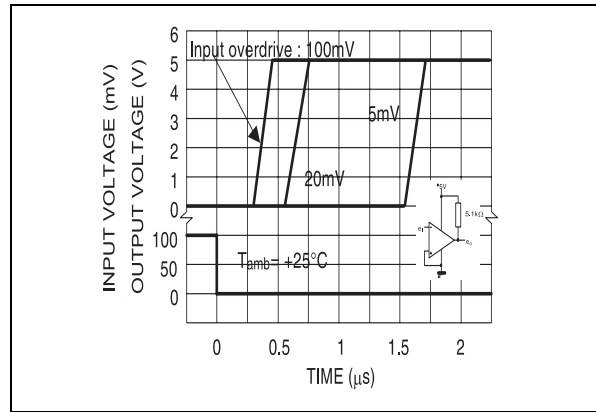

OUTPUT SATURATION VOLTAGE versus OUTPUT CURRENT

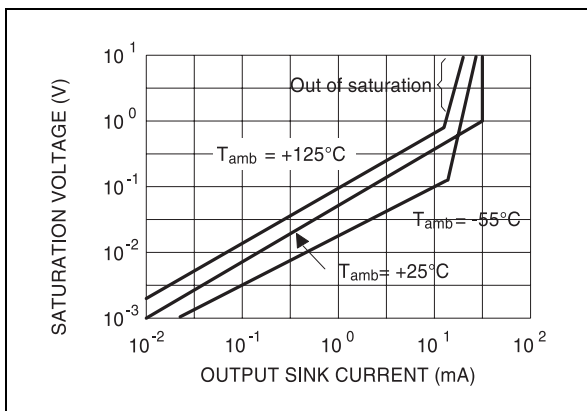

TYPICAL APPLICATIONS

BASIC COMPARATOR

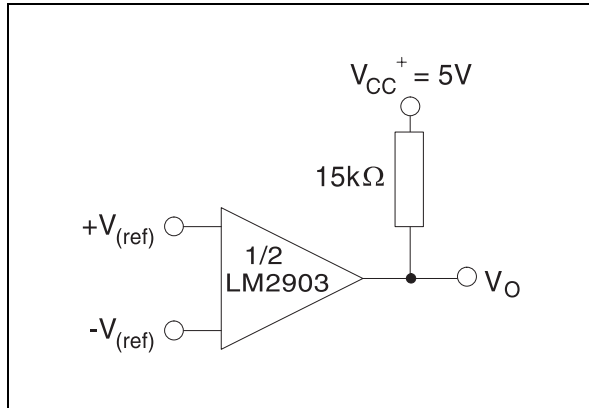

LOW FREQUENCY OP AMP

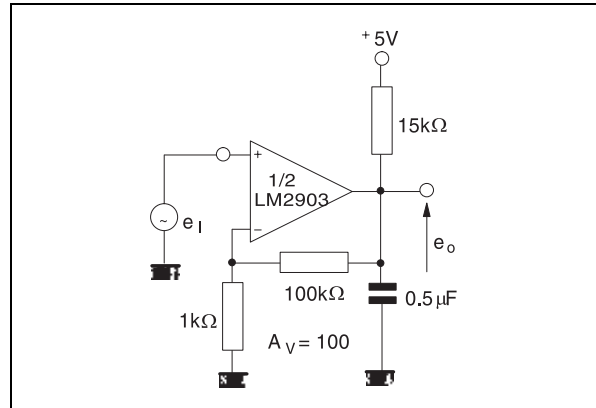

DRIVING CMOS

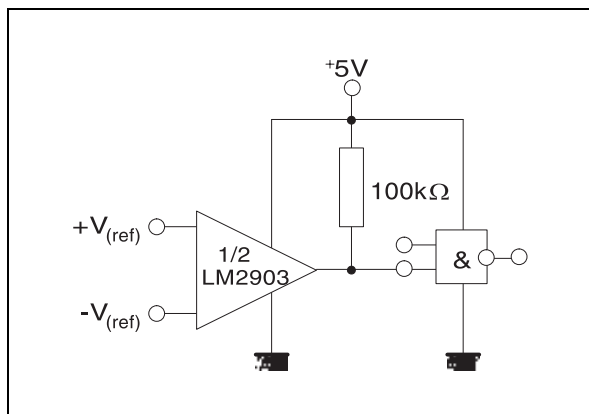

LOW FREQUENCY OP AMP

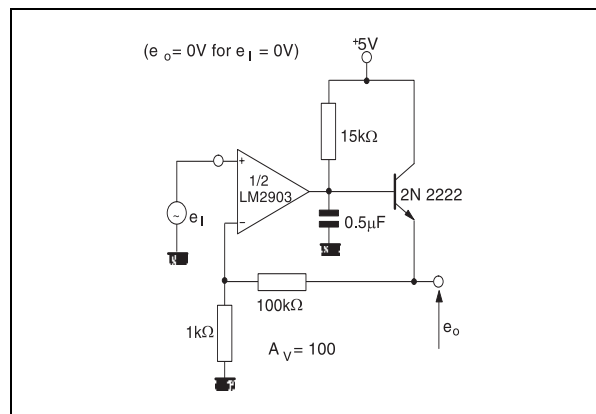

DRIVING TTL

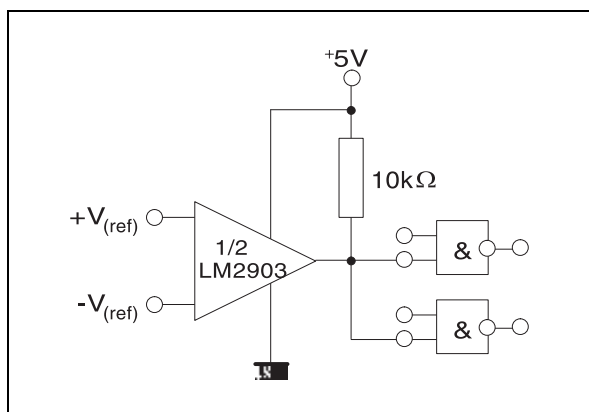

TRANSDUCER AMPLIFIER

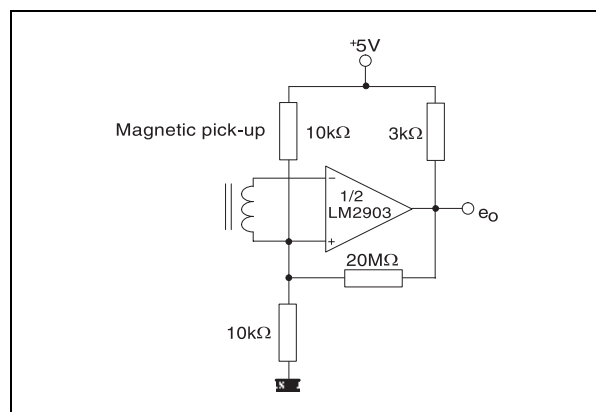

LOW FREQUENCY OP AMP WITH OFFSET ADJUST

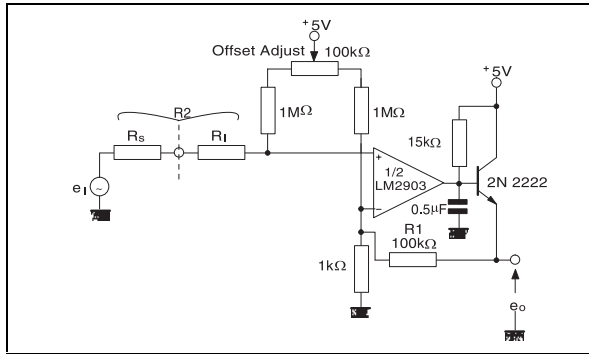

ZERO CROSSING DETECTOR (single power supply)

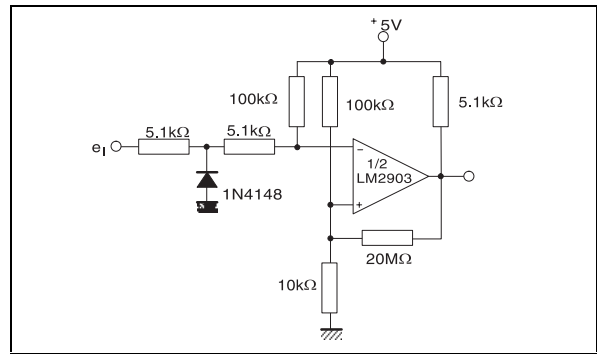

TWO-DECADE HIGH-FREQUENCY VCO

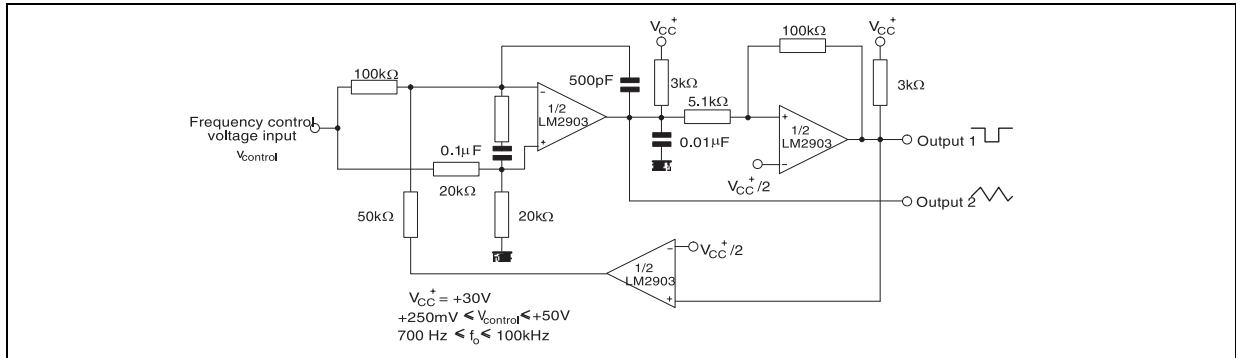

LIMIT COMPARATOR

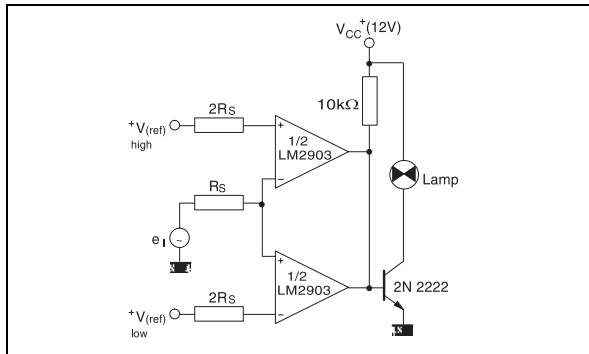

CRYSTAL CONTROLLED OSCILLATOR

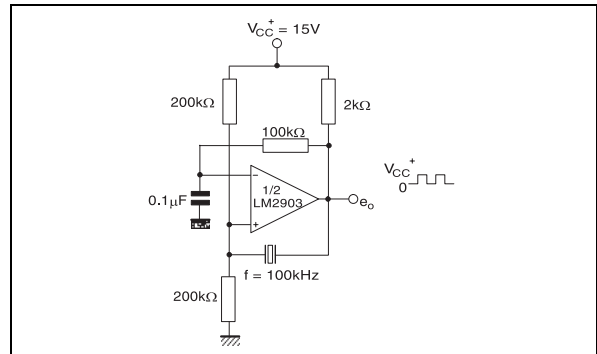

SPLIT-SUPPLY APPLICATIONS ZERO CROSSING DETECTOR

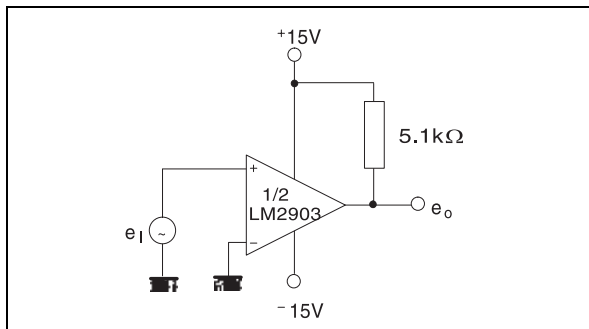

COMPARATOR WITH A NEGATIVE REFERENCE

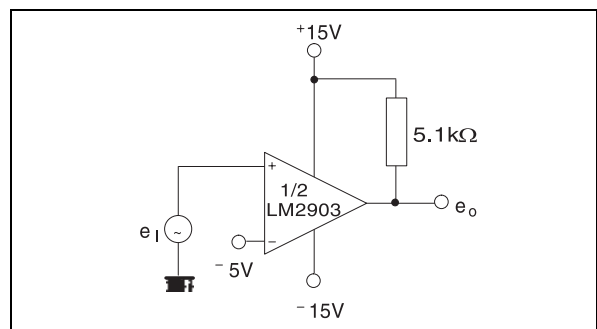

X-ON Electronics

Largest Supplier of Electrical and Electronic Components

Click to view similar products for [Analog Comparators](#) category:

Click to view products by [SLKORMICRO](#) manufacturer:

Other Similar products are found below :

[SC2903VDR2G](#) [LM2901SNG](#) [LM339SNG](#) [5962-8757203IA](#) [NTE911](#) [LM339EDR2G](#) [NTE922](#) [UPC311G2-E1-A](#) [UPC311G2-E2-A](#)
[UPC272G2-E1-A](#) [UPC277G2-E2-A](#) [UPC177G2-E2-A](#) [UPC271G2-E2-A](#) [TLV1811DBVR](#) [HT393VRMZ](#) [LM2903YD](#) [NCV2200SN1T1G](#)
[LM2903A-SR](#) [LM2903A-VR](#) [HT393ARZ](#) [LM2903](#) [LM2904](#) [LM393D](#) [LM393](#) [LMV331SN3T1G](#) [LMV331ILT](#) [LMV331W5](#)
[LMV331IDBVR](#) [LMV331M5X](#) [TPV331S5](#) [LM339A-SR](#) [GS8748-SR](#) [LM311MM/TR](#) [LM211MM/TR](#) [HT339ARQZ](#) [LM393DR-HXY](#)
[LM2903XK-Q1](#) [RS393XK-Q1](#) [LM2903XM](#) [RS339XQ](#) [LM331CXF](#) [RS393XM](#) [LM2901XP](#) [LM2901DR-JSM](#) [LM239DR-JSM](#) [LM339](#)
[LR2903D](#) [TS391IL](#) [LM331A-S5TR](#) [GSV331R-TR](#)