

Dual General Purpose Transistor

NPN+PNP Silicon

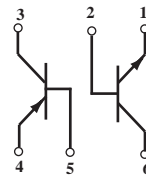

NPN+PNP

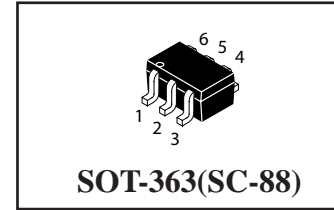

SOT-363(SC-88)

Maximum Ratings

Rating	Symbol	Value	Unit
Collector-Emitter Voltage (NPN) (PNP)	V_{CE0}	40 -40	Vdc
Collector-Base Voltage (NPN) (PNP)	V_{CBO}	60 -40	Vdc
Emitter-Base Voltage (NPN) (PNP)	V_{EBO}	6.0 -5.0	Vdc
Collector Current-Continuous (NPN) (PNP)	I_C	200 -200	mAdc

Thermal Characteristics

Characteristics	Symbol	Max	Unit
Total Package Dissipation ⁽¹⁾ $T_A=25^{\circ}\text{C}$	P_D	150	mW
Thermal Resistance, Junction to Ambient	$R_{\theta JA}$	833	$^{\circ}\text{C}/\text{W}$
Junction and Storage, Temperature	T_J, T_{stg}	-55 to +150	$^{\circ}\text{C}$

Off C characteristics

Collector-Emitter Breakdown Voltage ⁽²⁾ ($I_C=1.0\text{mA}$, $I_B=0$) (NPN) ($I_C=-1.0\text{mA}$, $I_B=0$) (PNP)	$V_{(BR)CEO}$	40 -40	- -	Vdc
Collector-Base Breakdown Voltage ($I_C=10\text{ }\mu\text{A}$, $I_E=0$) (NPN) ($I_C=-10\text{ }\mu\text{A}$, $I_E=0$) (PNP)	$V_{(BR)CBO}$	60 -40	- -	Vdc
Emitter-Base Breakdown Voltage ($I_E=10\text{ }\mu\text{A}$, $I_C=0$) (NPN) ($I_E=-10\text{ }\mu\text{A}$, $I_C=0$) (PNP)	$V_{(BR)EBO}$	6.0 -5.0	- -	Vdc
Base Cutoff Current ($V_{CE}=30\text{ Vdc}$, $V_{EB}=3.0\text{ Vdc}$) (NPN) ($V_{CE}=-30\text{ Vdc}$, $V_{EB}=-3.0\text{ Vdc}$) (PNP)	IBL	- -	50 -50	nA
Collector Cutoff Current ($V_{CE}=30\text{Vdc}$, $V_{EB}=3.0\text{Vdc}$) (NPN) ($V_{CE}=-30\text{Vdc}$, $V_{EB}=-3.0\text{Vdc}$) (PNP)	ICEX	- -	50 -50	nA

1. Device Mounted on FR4 glass epoxy printed circuit board using the minimum recommended footprint.
2. Pulse Test:Pulse Width $\leq 300\text{ }\mu\text{s}$, Duty Cycle $\leq 2.0\%$.

Electrical Characteristics ($T_A=25^\circ\text{C}$ unless otherwise noted) (Continued)

Characteristics	Symbol	Min	Max	Unit
-----------------	--------	-----	-----	------

On Characteristics ⁽²⁾

DC Current Gain ($I_C=0.1\text{ mA}$, $V_{CE}=1.0\text{Vdc}$) (NPN) ($I_C=1.0\text{ mA}$, $V_{CE}=1.0\text{ Vdc}$) ($I_C=10\text{ mA}$, $V_{CE}=1.0\text{Vdc}$) ($I_C=50\text{ mA}$, $V_{CE}=1.0\text{Vdc}$) ($I_C=100\text{ mA}$, $V_{CE}=1.0\text{Vdc}$) ($I_C=-0.1\text{ mA}$, $V_{CE}=-1.0\text{Vdc}$) (PNP) ($I_C=-1.0\text{ mA}$, $V_{CE}=-1.0\text{ Vdc}$) ($I_C=-10\text{ mA}$, $V_{CE}=-1.0\text{Vdc}$) ($I_C=-50\text{ mA}$, $V_{CE}=-1.0\text{Vdc}$) ($I_C=-100\text{ mA}$, $V_{CE}=-1.0\text{Vdc}$)	H_{FE}	40 70 100 60 30 60 80 100 60 30	- - 300 - - - - 300 - -	-
Collector-Emitter Saturation Voltage ($I_C=10\text{ mA}$, $I_B=1.0\text{mA}$) (NPN) ($I_C=50\text{ mA}$, $I_B=5.0\text{mA}$) ($I_C=-10\text{ mA}$, $I_B=-1.0\text{mA}$) (PNP) ($I_C=-50\text{ mA}$, $I_B=-5.0\text{mA}$)	$V_{CE(sat)}$	- - - -	0.20 0.30 -0.25 -0.40	Vdc
Base-Emitter Saturation Voltage ($I_C=10\text{ mA}$, $I_B=1.0\text{ mA}$) (NPN) ($I_C=50\text{ mA}$, $I_B=5.0\text{ mA}$) ($I_C=-10\text{ mA}$, $I_B=-1.0\text{ mA}$) (PNP) ($I_C=-50\text{ mA}$, $I_B=-5.0\text{ mA}$)	$V_{BE(sat)}$	0.65 - -0.65 -	0.85 0.95 -0.85 -0.95	Vdc

Small-signal Characteristics

Current-Gain-Bandwidth Product ($I_C = 10 \text{ mAdc}$, $V_{CE} = 20 \text{ Vdc}$, $f = 100\text{MHz}$) (NPN) ($I_C = -10 \text{ mAdc}$, $V_{CE} = -20 \text{ Vdc}$, $f = 100\text{MHz}$) (PNP)	f_T	300 250	- -	MHz
Output Capacitance ($V_{CB} = 5.0 \text{ Vdc}$, $I_E = 0$, $f = 1.0\text{MHz}$) (NPN) ($V_{CB} = -5.0 \text{ Vdc}$, $I_E = 0$, $f = 1.0\text{MHz}$) (PNP)	C_{obo}	- -	4.0 4.5	pF
Input Capacitance ($V_{EB} = 0.5 \text{ Vdc}$, $I_C = 0$, $f = 1.0\text{MHz}$) (NPN) ($V_{EB} = -0.5 \text{ Vdc}$, $I_C = 0$, $f = 1.0\text{MHz}$) (PNP)	C_{ibo}	- -	8.0 10.0	pF
Input Impedance ($V_{CE} = 10 \text{ Vdc}$, $I_C = 1.0 \text{ mAdc}$, $f = 1.0 \text{ kHz}$) (NPN) ($V_{CE} = -10 \text{ Vdc}$, $I_C = -1.0 \text{ mAdc}$, $f = 1.0 \text{ kHz}$) (PNP)	h_{ie}	1.0 2.0	10 12	k ohms
Voltage Feedback Ratio ($V_{CE} = 10\text{Vdc}$, $I_C = 1.0 \text{ mAdc}$, $f = 1.0 \text{ kHz}$) (NPN) ($V_{CE} = -10\text{Vdc}$, $I_C = -1.0 \text{ mAdc}$, $f = 1.0 \text{ kHz}$) (PNP)	h_{re}	0.5 0.1	8.0 10	$\times 10^{-4}$
Small-Signal Current Gain ($V_{CE} = 10\text{Vdc}$, $I_C = 1.0 \text{ mAdc}$, $f = 1.0 \text{ kHz}$) (NPN) ($V_{CE} = -10\text{Vdc}$, $I_C = -1.0 \text{ mAdc}$, $f = 1.0 \text{ kHz}$) (PNP)	h_{fe}	100 100	400 400	-
Output Admittance ($V_{CE} = 10\text{Vdc}$, $I_C = 1.0 \text{ mAdc}$, $f = 1.0\text{kHz}$) (NPN) ($V_{CE} = -10\text{Vdc}$, $I_C = -1.0 \text{ mAdc}$, $f = 1.0\text{kHz}$) (PNP)	h_{oe}	1.0 3.0	40 60	μmhos
Noise Figure ($V_{CE} = 5.0\text{Vdc}$, $I_C = 100 \mu\text{A}$, $R_S = 1.0\text{k ohms}$, $f = 1.0\text{kHz}$) (NPN) ($V_{CE} = -5.0\text{Vdc}$, $I_C = -100 \mu\text{A}$, $R_S = 1.0\text{k ohms}$, $f = 1.0\text{kHz}$) (PNP)	NF	- -	5.0 4.0	dB

Switching Characteristics

Delay Time ($V_{CC} = 3.0 \text{ Vdc}$, $V_{BE} = -0.5 \text{ Vdc}$) (NPN) ($I_C = 10 \text{ mAdc}$, $I_{B1} = 1.0 \text{ mAdc}$)	t_d	-	35 35	ns
Rise Time ($V_{CC} = -3.0 \text{ Vdc}$, $V_{BE} = 0.5 \text{ Vdc}$) (PNP) ($I_C = -10 \text{ mAdc}$, $I_{B1} = -1.0 \text{ mAdc}$)	t_r	-	35 35	ns
Storage Time ($V_{CC} = 3.0 \text{ Vdc}$, $I_C = 10 \text{ mAdc}$) (NPN) ($I_C = 10 \text{ mAdc}$, $I_{B1} = I_{B2} = 1.0 \text{ mAdc}$)	t_s	-	200 225	ns
Fall Time ($V_{CC} = -3.0 \text{ Vdc}$, $I_C = -10 \text{ mAdc}$) (PNP) ($I_C = -10 \text{ mAdc}$, $I_{B1} = I_{B2} = -1.0 \text{ mAdc}$)	t_f	-	50 75	ns

(NPN)

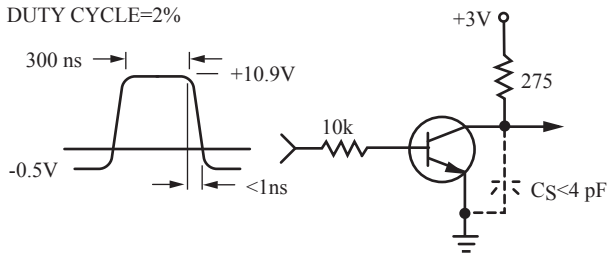

Figure 1. Delay and Rise Time Equivalent Test Circuit

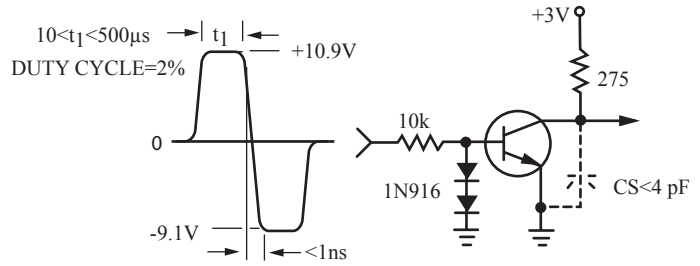

Figure 2. Storage and Fall Time Equivalent Test Circuit

*Total shunt capacitance of test jig and connectors

TYPICAL TRANSIENT CHARACTERISTICS

— $T_J=25^\circ\text{C}$ - - - $T_J=125^\circ\text{C}$

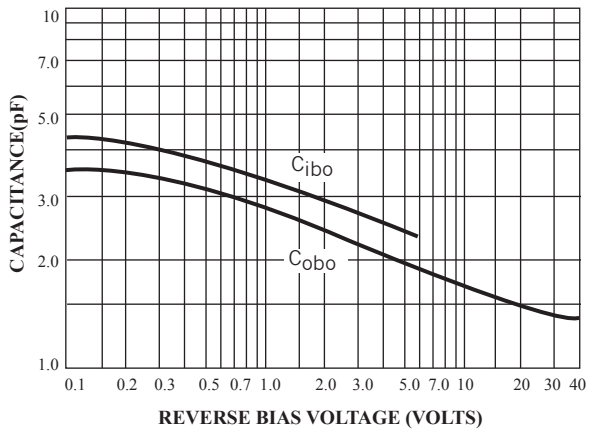

Figure 3. Capacitance

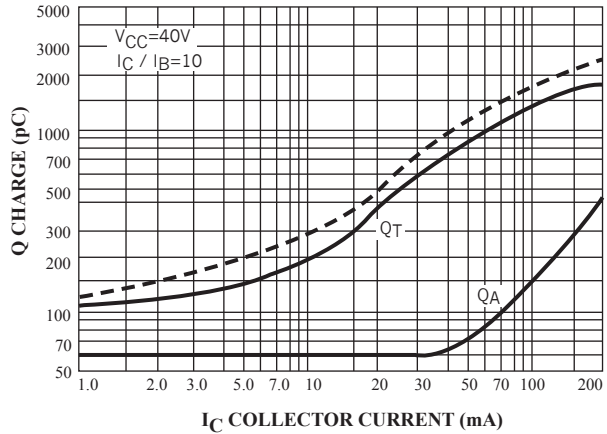

Figure 4. Charge Data

(NPN)

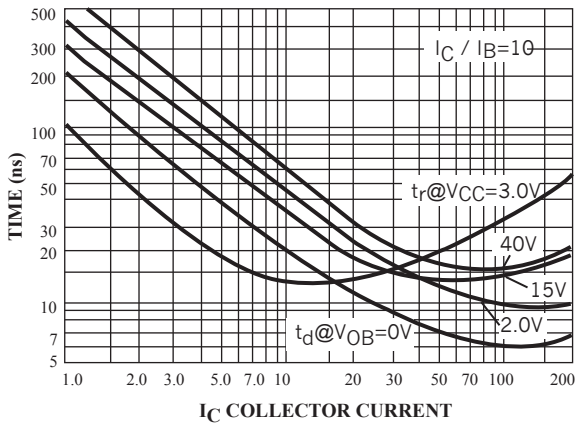

Figure 5. Turn-On Time

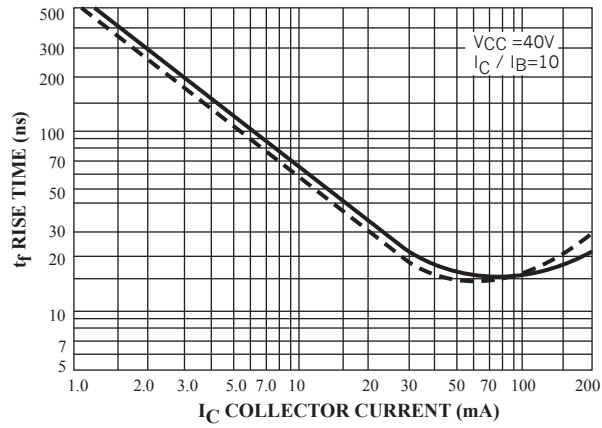

Figure 6. Rise Time

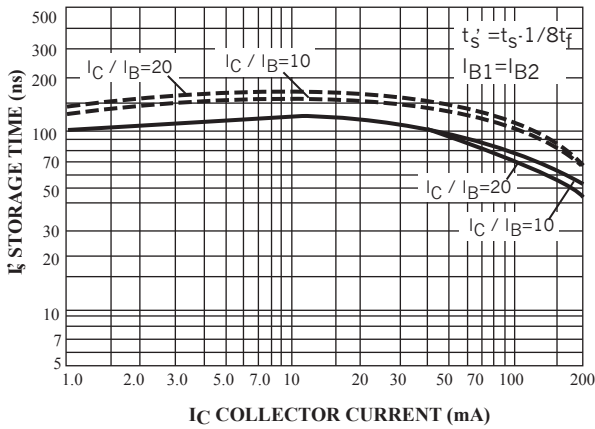

Figure 7. Storage Time

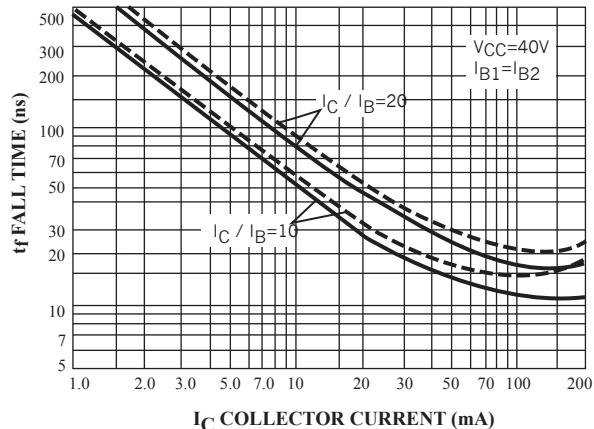

Figure 8. Fall Time

TYPICAL AUDIO SMALL-SIGNAL CHARACTERISTICS NOISE FIGURE VARIATIONS
($V_{CE}=5.0$ Vdc, $T_A=25^\circ$ C, Bandwidth=1.0Hz)

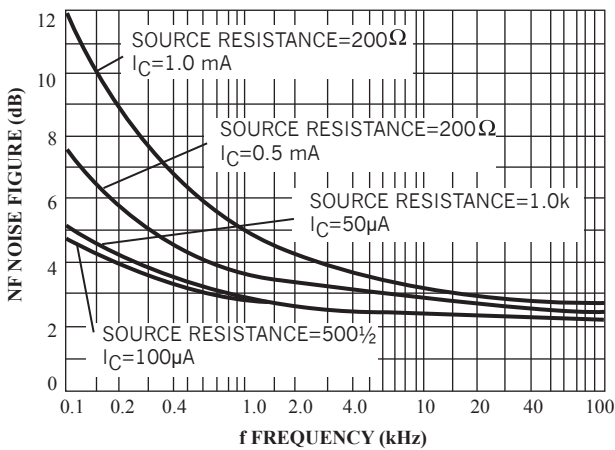

Figure 9.

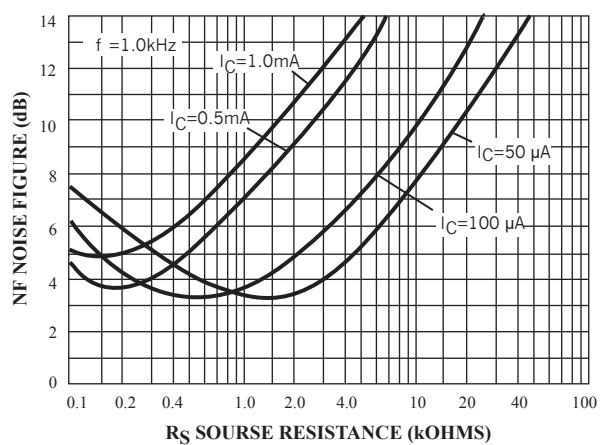

Figure 10.

h PARAMETERS $(V_{CE}=10\text{ Vdc}, m\ f=1.0\text{ kHz}, T_A=25^\circ\text{C})$

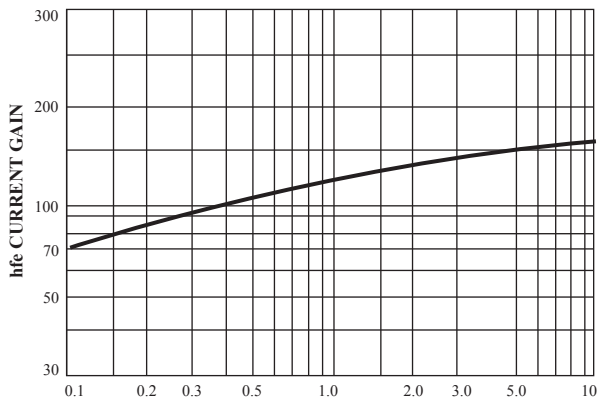

Figure 11. Current Gain

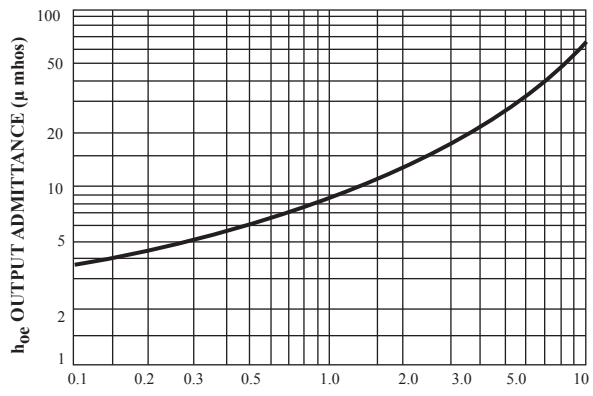

Figure 12. Output Admittance

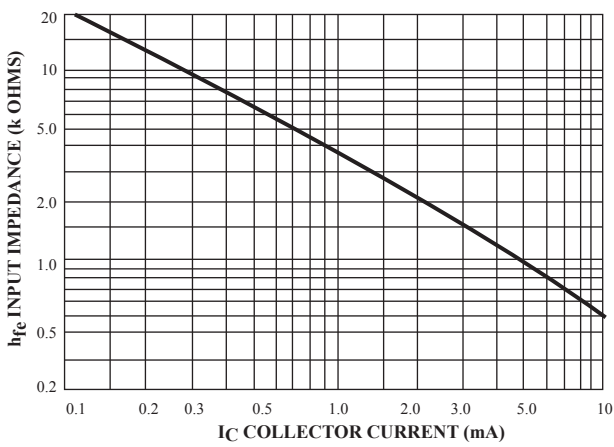

Figure 13. Input Impedance

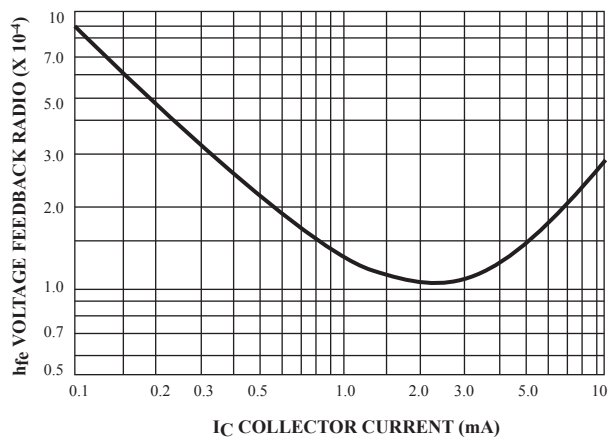

Figure 14. Voltage Feedback Ratio

TYPICAL STATIC CHARACTERISTICS

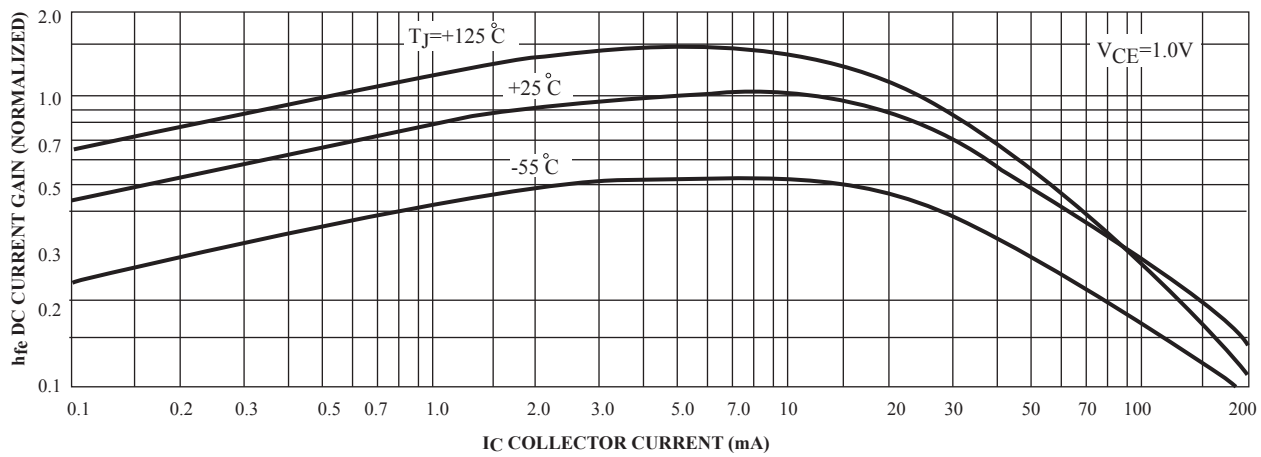

Figure 15. DC Current Gain

(NPN)

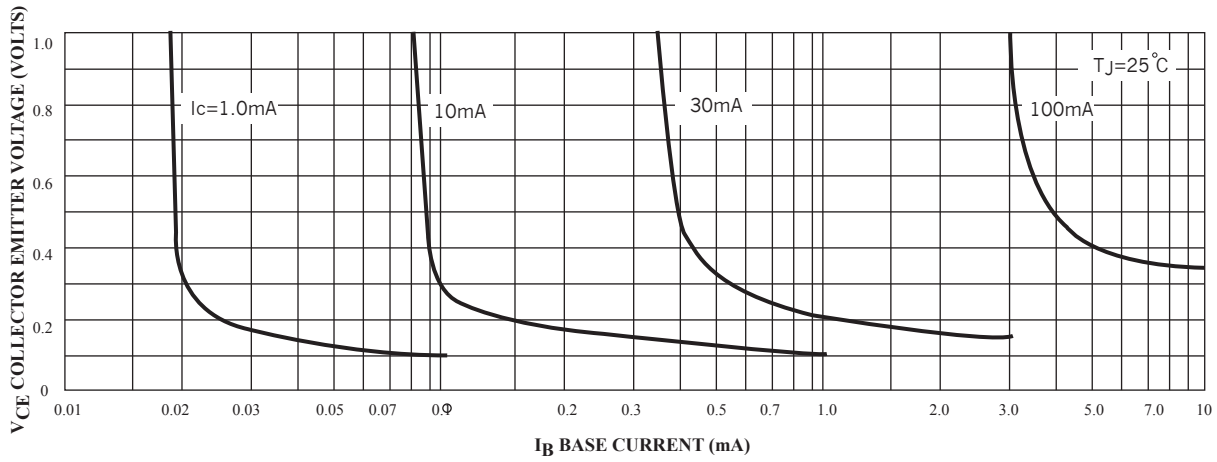

Figure 16. Collector Saturation Region

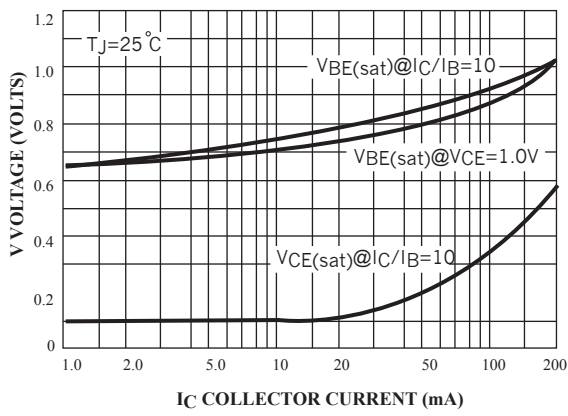

Figure 17. "ON" Voltage

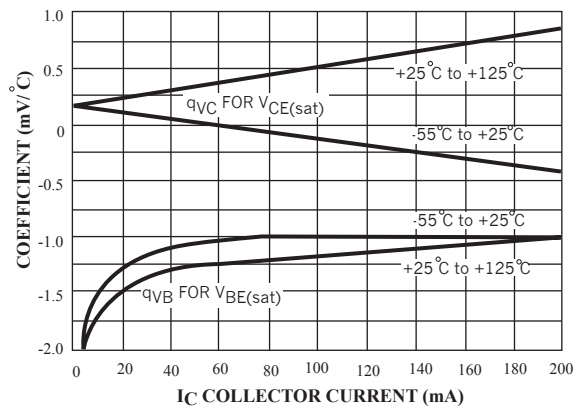

Figure 18. Temperature Coefficients

(PNP)

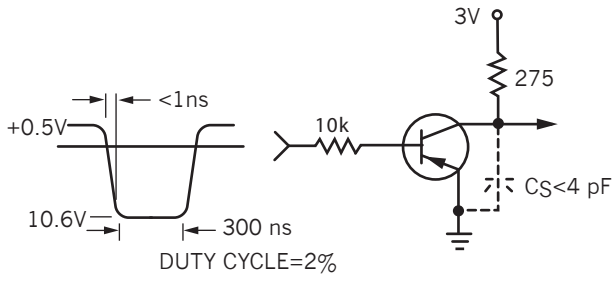

Figure 19. Delay and Rise Time Equivalent Test Circuit

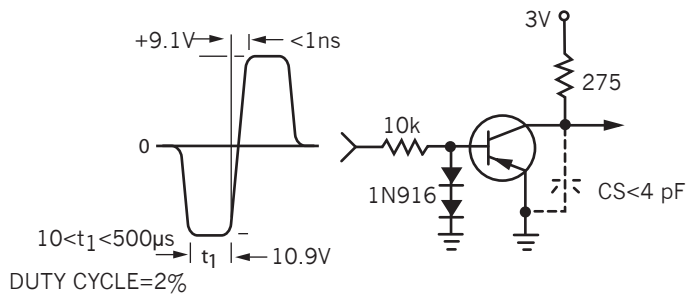

Figure 20. Storage and Fall Time Equivalent Test Circuit

*Total shunt capacitance of test jig and connectors

TYPICAL TRANSIENT CHARACTERISTICS

—— $T_J=25^\circ\text{C}$ - - - - $T_J=125^\circ\text{C}$

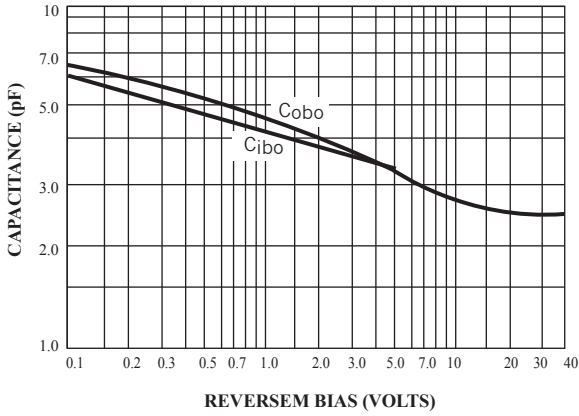

Figure 21. Capacitance

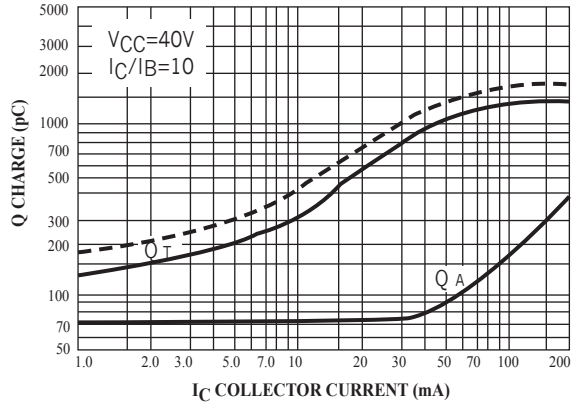

Figure 22. Charge Data

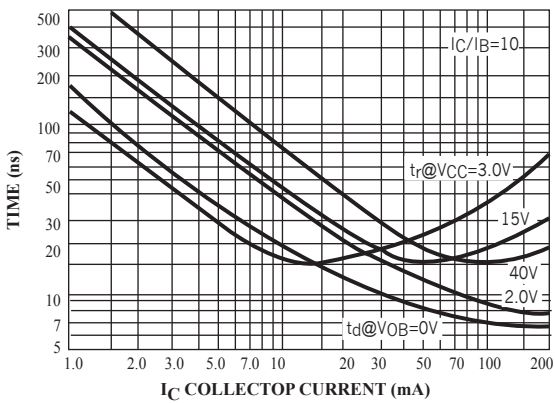

Figure 23. Turn-On Time

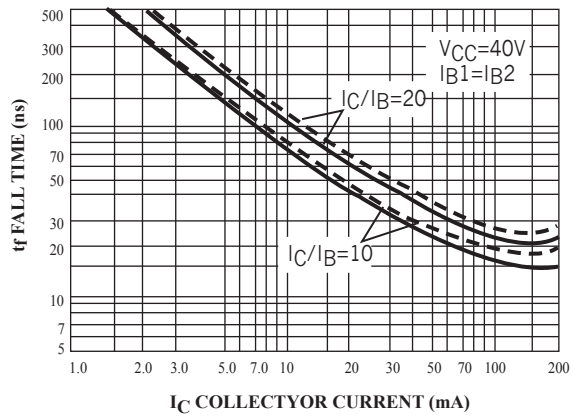

Figure 24. Fall Time

(PNP)

TYPICAL AUDIO SMALL-SIGNAL CHARACTERISTICS NOISE FIGURE VARIATIONS

($V_{CE} = -5.0$ Vdc, $T_A = 25^\circ\text{C}$, Bandwidth= 1.0Hz)

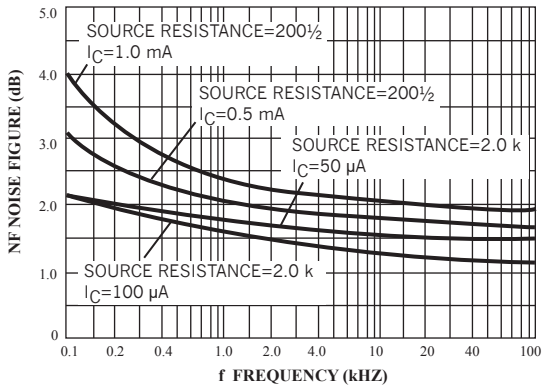

Figure 25.

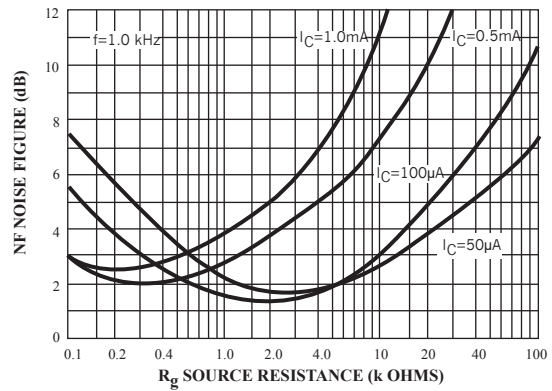

Figure 26.

h PARAMETERS ($V_{CE} = -10$ Vdc, $f = 1.0$ kHz, $T_A = 25^\circ\text{C}$)

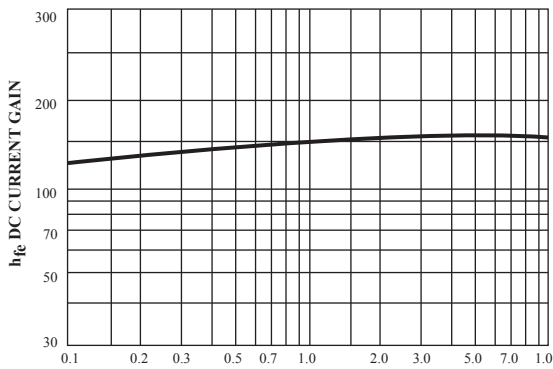

Figure 27. Current Gain

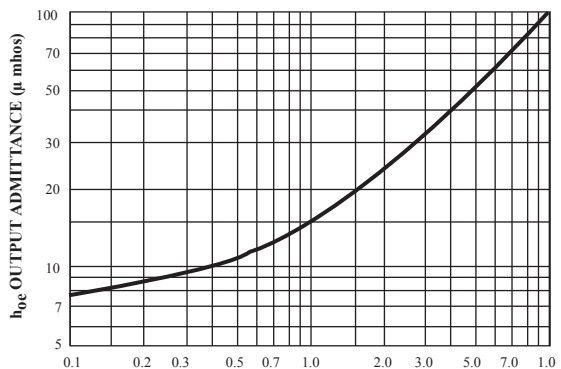

Figure 28. Input Impedance

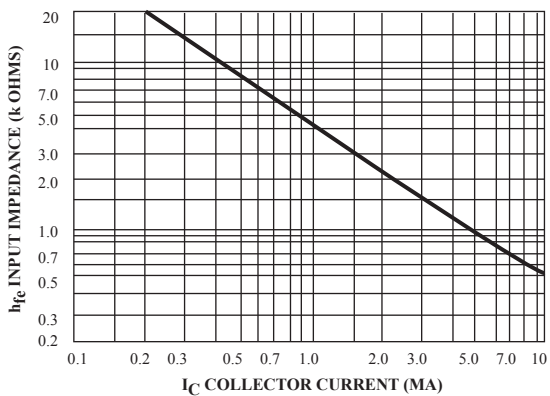

Figure 29. Input Impedance

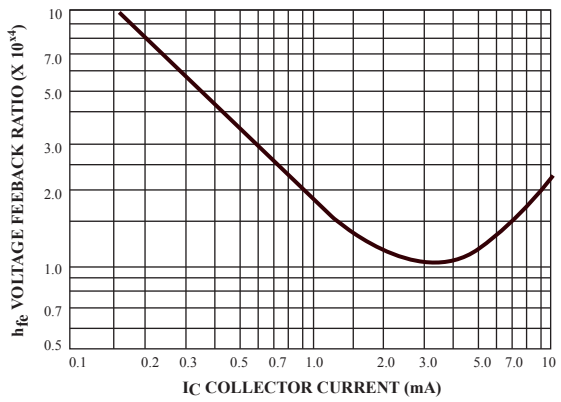

Figure 30. Votage Feedback Ratio

(PNP)

TYPICAL STATIC CHARACTERISTICS

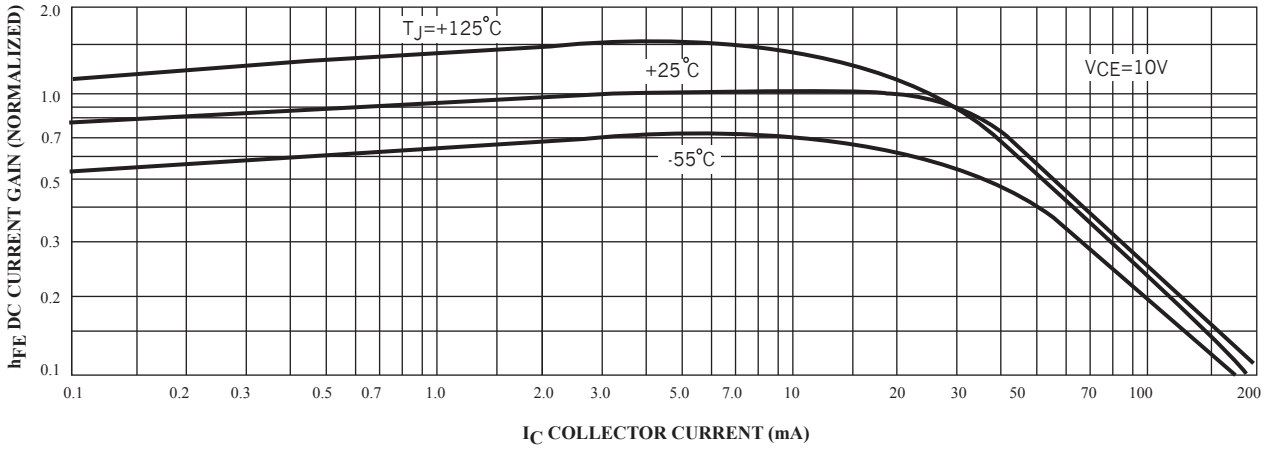

Figure 31. DC Current Gain

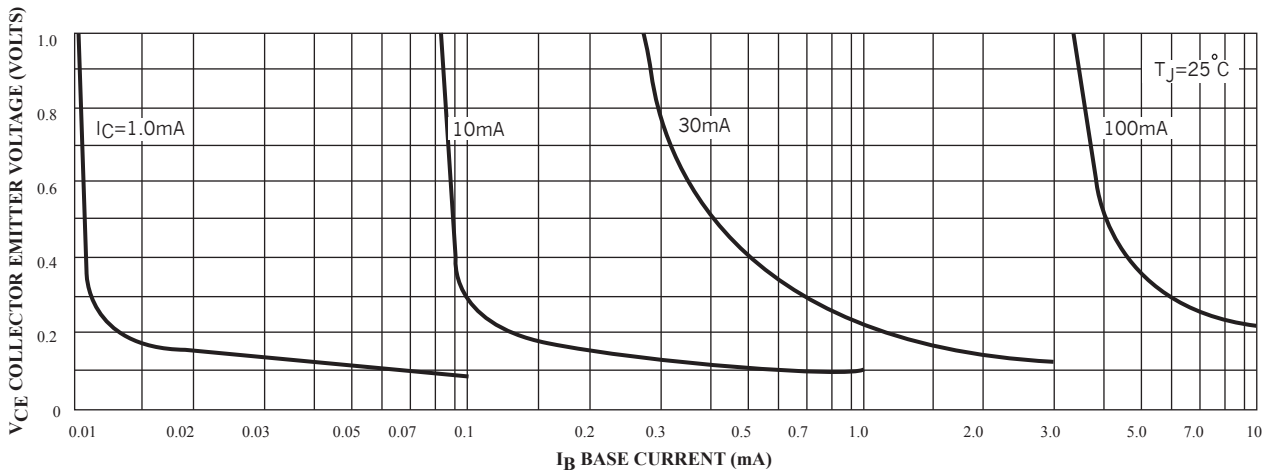

Figure 32. Collector Saturation Region

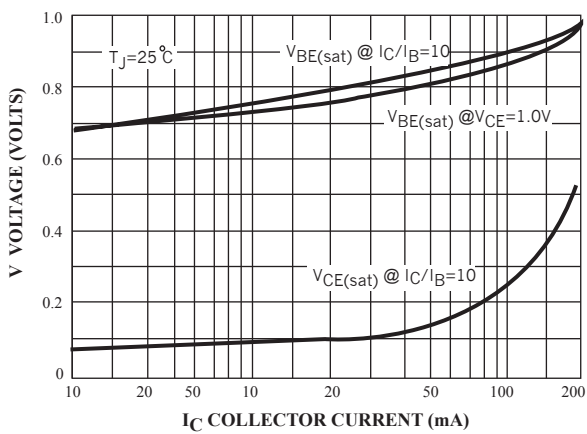

Figure 33. "ON" Voltages

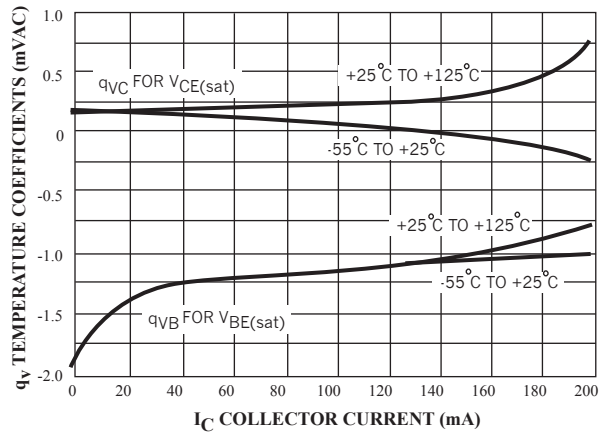
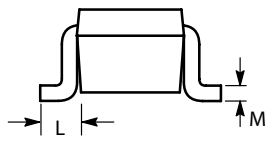
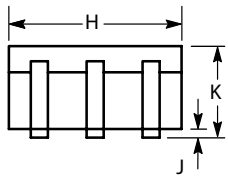
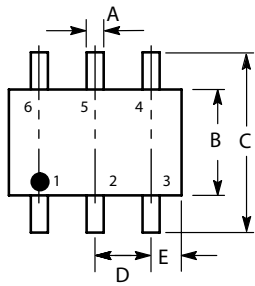

Figure 34. Temperature Coefficients

SOT-363 Package Outline Dimensions

Unit:mm



SOT-363		
Dim	Min	Max
A	0.10	0.30
B	1.15	1.35
C	2.00	2.20
D	0.65 REF	
E	0.30	0.40
H	1.80	2.20
J	-	0.10
K	0.80	1.10
L	0.25	0.40
M	0.10	0.25

X-ON Electronics

Largest Supplier of Electrical and Electronic Components

Click to view similar products for [Bipolar Transistors - BJT category](#):

Click to view products by [SLKORMICRO manufacturer](#):

Other Similar products are found below :

[619691C](#) [MCH4017-TL-H](#) [MJ15024/WS](#) [MJ15025/WS](#) [BC546/116](#) [BC556/FSC](#) [BC557/116](#) [BSW67A](#) [HN7G01FU-A\(T5L,F,T](#)
[NJVMJD148T4G](#) [NSVMMBT6520LT1G](#) [NTE187A](#) [NTE195A](#) [NTE2302](#) [NTE2330](#) [NTE2353](#) [NTE316](#) [IMX9T110](#) [NTE63](#) [NTE65](#)
[C4460](#) [SBC846BLT3G](#) [2SA1419T-TD-H](#) [2SA1721-O\(TE85L,F\)](#) [2SA1727TLP](#) [2SA2126-E](#) [2SB1202T-TL-E](#) [2SB1204S-TL-E](#) [2SC5488A-](#)
[TL-H](#) [2SD2150T100R](#) [SP000011176](#) [FMC5AT148](#) [2N2369ADCSM](#) [2SB1202S-TL-E](#) [2SC2412KT146S](#) [2SC4618TLN](#) [2SC5490A-TL-H](#)
[2SD1816S-TL-E](#) [2SD1816T-TL-E](#) [CMXT2207 TR](#) [CPH6501-TL-E](#) [MCH4021-TL-E](#) [BC557B](#) [TTC012\(Q\)](#) [BULD128DT4](#) [JANTX2N3810](#)
[Jantx2N5416](#) [US6T6TR](#) [KSF350](#) [068071B](#)