

## N-Channel Enhancement Mode Power MOSFET

### Description

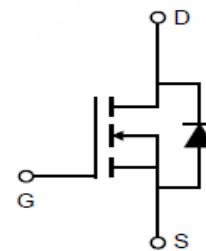
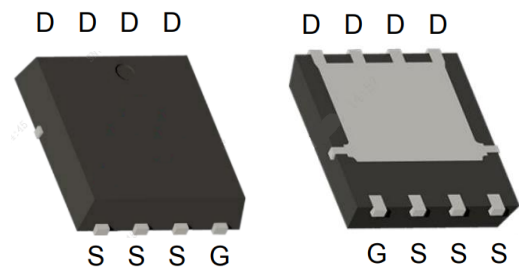
This Power MOSFET is produced using advanced Trench technology.

This devices provide an excellent gate charge and  $R_{DS(on)}$ , which leads to extremely communication and conduction losses. So it is very suitable for AC/DC power conversion, load switch and industrial power applications.

### Features

- $V_{DS}=30V$ ,  $I_D=100A$
- $R_{DS(on)}$  Typ= $2.9m\ \Omega$  @  $V_{GS}=10V$
- $R_{DS(on)}$  Typ= $4.8m\ \Omega$  @  $V_{GS}=4.5V$
- Low FOM  $R_{DS(on)} \times Q_{gd}$
- 100% avalanche tested
- Easy to use/drive
- RoHS compliant

PDFN5\*6-8L



Schematic diagram

### Applications

- Power Management
- PWM Application
- Load Switch

*100% UIS TESTED!*

*100%  $\Delta V_{ds}$  TESTED!*

### Package Marking and Ordering Information

Device	Marking	Package	Packing	Reel (pcs)
SL100N03R		PDFN5*6	Reel	5000

### Absolute Maximum Ratings

Parameter		Symbol	Value	Unit
Drain-source Voltage		$V_{DS}$	30	V
Gate-source Voltage		$V_{GS}$	$\pm 20$	V
Continuous Drain Current <sup>(2)</sup>	$T_C=25^\circ\text{C}$	$I_D$	100	A
	$T_C=100^\circ\text{C}$		65	
Pulsed Drain Current( $T_C=25^\circ\text{C}, T_p$ Limited By $T_{jmax}$ ) <sup>(3)</sup>		$I_{DM}$	400	A
Maximum Power Dissipation( $T_C=25^\circ\text{C}$ )		$P_D$	70	W
Avalanche energy , single Pulse( $L=0.5\text{mH}$ ) <sup>(1)</sup>		$E_{AS}$	121	mJ
Operating Junction And Storage Temperature		$T_j, T_{stg}$	-55 To 150	$^\circ\text{C}$
Maximum lead temperature for soldering purposes, 1/8" from case for 5 seconds		$T_L$	300	$^\circ\text{C}$

\* Drain current limited by maximum junction temperature.

### Thermal Resistance

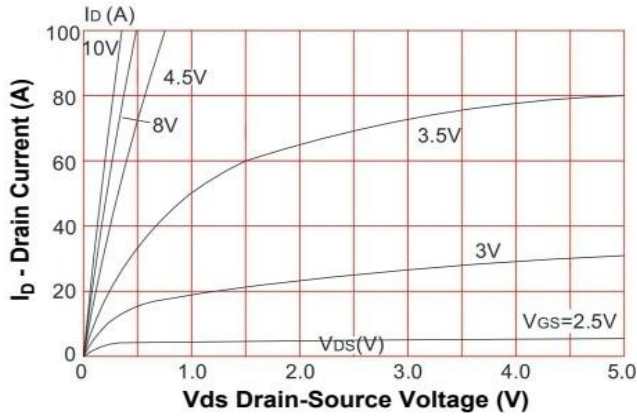
Parameter	Symbol	Max	Unit
Junction-to-Case	$R_{\theta JC}$	2.14	$^\circ\text{C/W}$

Notes:

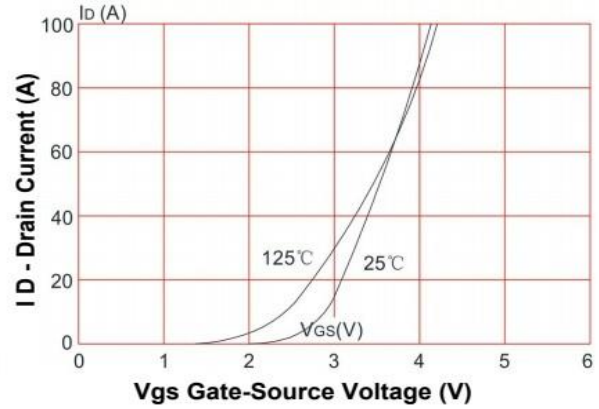
- 1)  $L=0.5\text{mH}$ ,  $V_{DD}=30\text{V}$ , Start  $T_j=25^\circ\text{C}$ .
- 2) Limited by maximum junction temperature.
- 3) Repetitive Rating: Pulse width limited by maximum junction temperature.

Parameter	Symbol	Value			Unit	Test Condition
		Min.	Typ.	Max.		
<b>Off Characteristic</b>						
Drain-source breakdown voltage	$BV_{DSS}$	30	-	-	V	$V_{GS}=0V, I_D=250\mu A$
Zero gate voltage drain current	$I_{DSS}$	-	-	1	$\mu A$	$V_{DS}=20V, V_{GS}=0V, T_J=25^\circ C$
		-	-	10	$\mu A$	$V_{DS}=16V, V_{GS}=0V, T_J=125^\circ C$
Gate-source leakage current	$I_{GSS}$	-	-	$\pm 100$	nA	$V_{GS}=\pm 20V, V_{DS}=0V$
<b>On Characteristics</b>						
Gate threshold voltage	$V_{GS(th)}$	1.0	1.5	2.5	V	$V_{DS}=V_{GS}, I_D=250\mu A$
Drain-source on-state resistance	$R_{DS(on)}$	-	2.8	4	m $\Omega$	$V_{GS}=10V, I_D=30A$
Drain-source on-state resistance	$R_{DS(on)}$	-	4.6	6.5	m $\Omega$	$V_{GS}=4.5V, I_D=20A$
<b>Dynamic Characteristic</b>						
Input Capacitance	$C_{iss}$	-	2650	-	PF	$V_{GS}=0V, V_{DS}=15V, f=1.0MHz$
Output Capacitance	$C_{oss}$	-	393	-		
Reverse Transfer Capacitance	$C_{rss}$	-	330	-		
<b>Switching Characteristics</b>						
Turn-on delay time	$t_{d(on)}$	-	23	-	nS	$V_{DS} = 15V, V_{GS} = 10V$ $R_G = 3\Omega, I_D = 30A$
Turn-on Rise time	$t_r$	-	28	-		
Turn-off delay time	$t_{d(off)}$	-	74	-		
Turn-off Fall time	$t_f$	-	36	-		
Gate Total Charge	$Q_G$	-	30	-	nC	$V_{GS}=10V, V_{DS}=15V,$ $I_D=30A$
Gate-Source Charge	$Q_{gs}$	-	7.2	-		
Gate-Drain Charge	$Q_{gd}$	-	10.4	-		
<b>Drain-Source Diode Characteristics</b>						
Body Diode Forward Voltage	$V_{SD}$	-	-	1.2	V	$V_{GS}=0V, I_{SD}=30A, T_J = 25^\circ C$
Body Diode Forward Current	$I_S$	-	-	100	A	-
Body Diode Reverse Recovery Time	$T_{rr}$	-	28	-	ns	$T_J=25^\circ C, I_{SD}=20A, V_{GS}=0V,$
Body Diode Reverse Recovery Charge	$Q_{rr}$	-	21	-	nC	$d_i/d_t = 100A/\mu s$

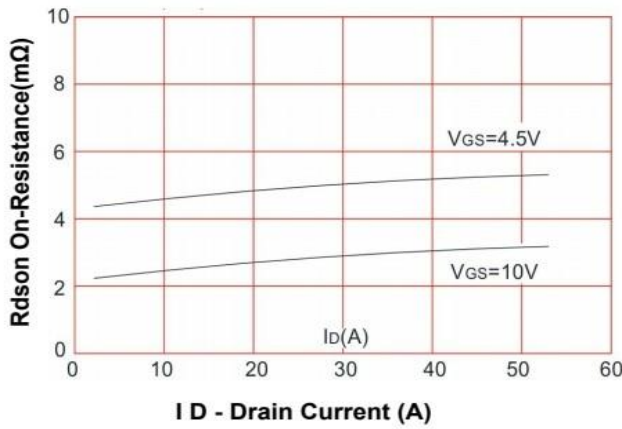
**N- Channel Typical Characteristics**



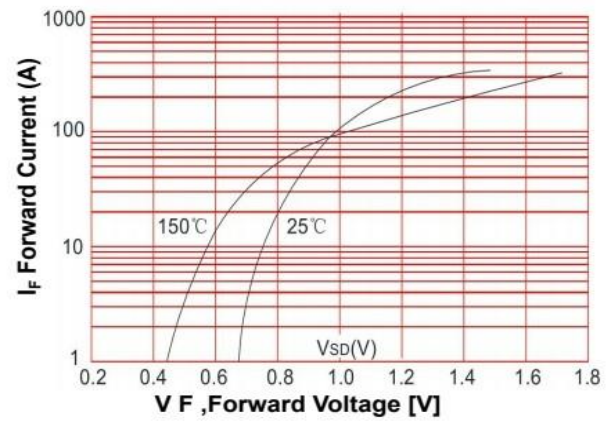
**Figure 1. On-Region Characteristics**



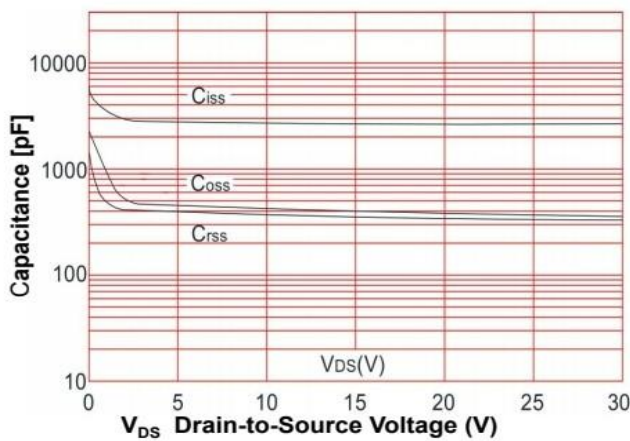
**Figure 2. Transfer Characteristics**



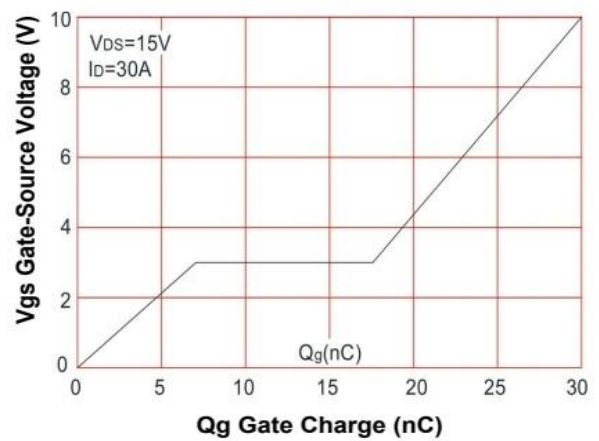
**Figure 3. On-Resistance Variation vs Drain Current and Gate Voltage**



**Figure 4. Body Diode Forward Voltage Variation with Source Current and Temperature**

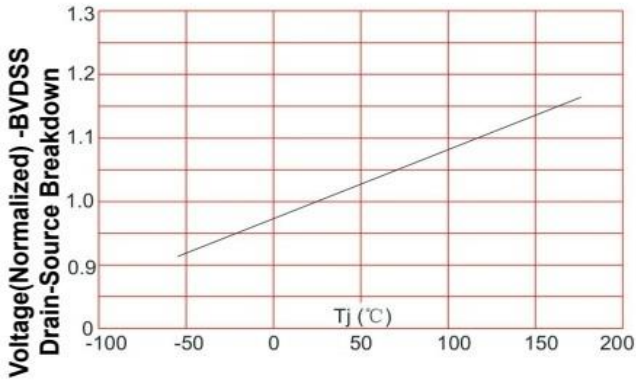


**Figure 5. Capacitance Characteristics**

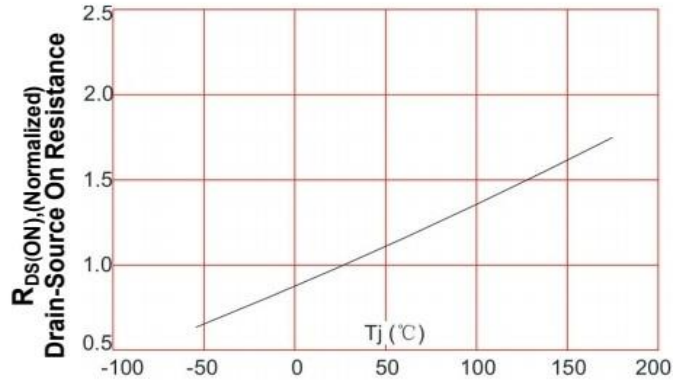


**Figure 6. Gate Charge Characteristics**

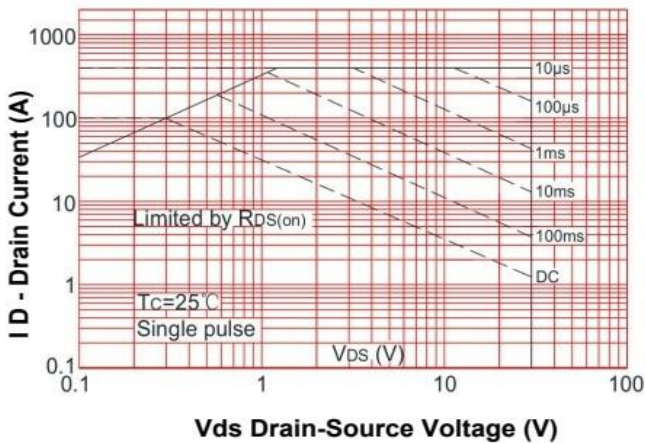
**N- Channel Typical Characteristics (Continued)**



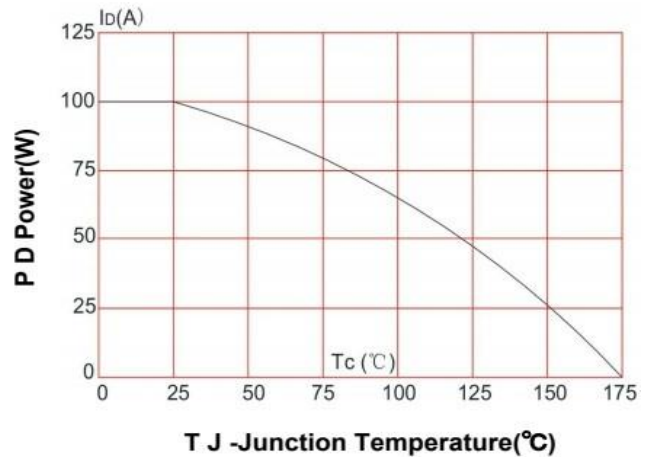
**T J , Junction Temperature [°C]**  
**Figure 7. Breakdown Voltage Variation vs Temperature**



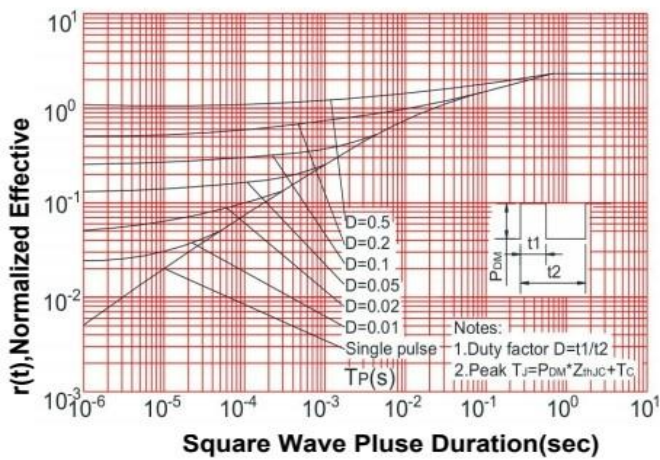
**T J , Junction Temperature [°C]**  
**Figure 8. On-Resistance Variation vs Temperature**



**Figure 9. Maximum Safe Operating Area**

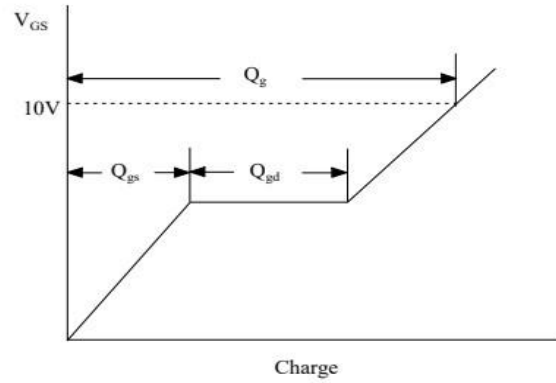
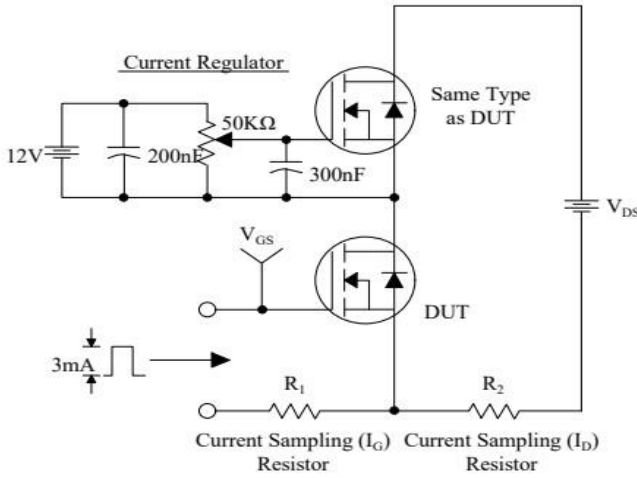


**Figure 10. Maximum Power Dissipation vs Case Temperature**

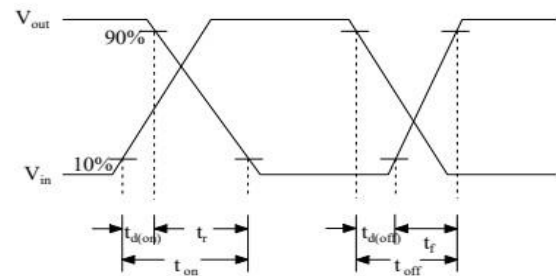
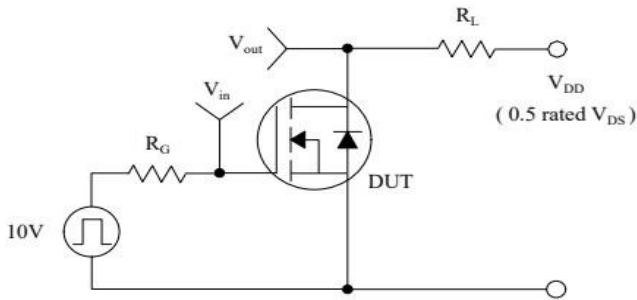


**Figure 11. Transient Thermal Response Curve**

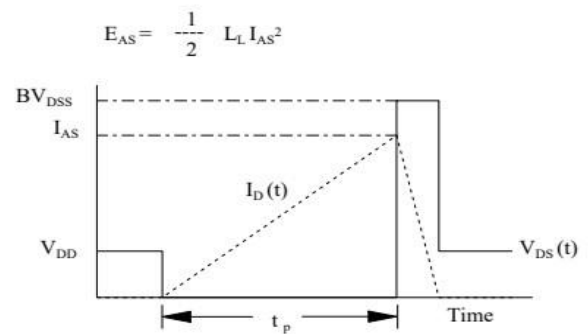
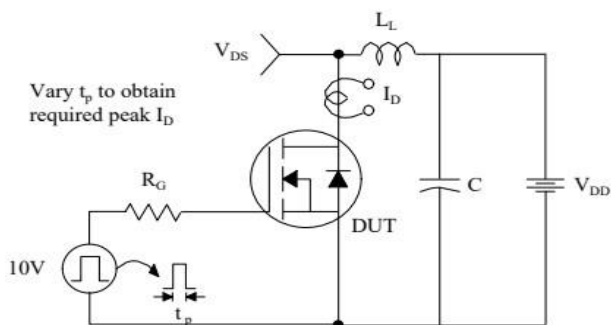
**Gate Charge Test Circuit & Waveform**



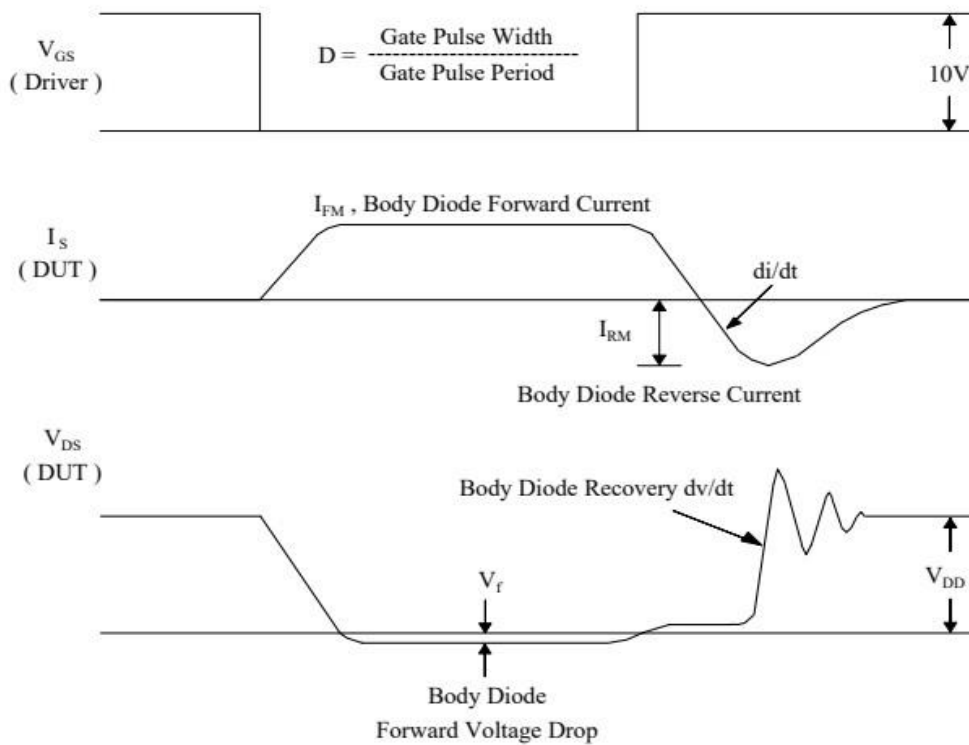
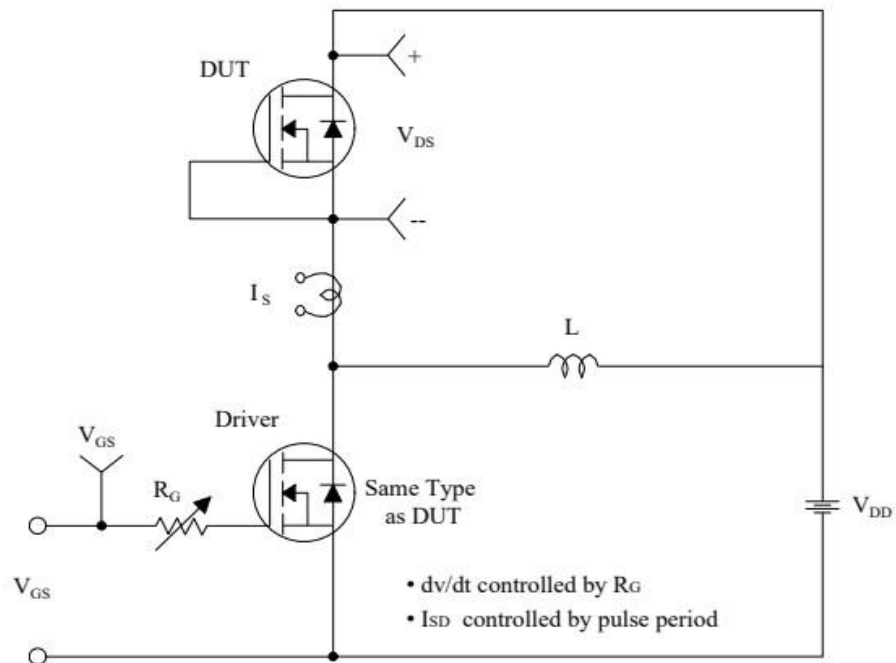
**Resistive Switching Test Circuit & Waveforms**

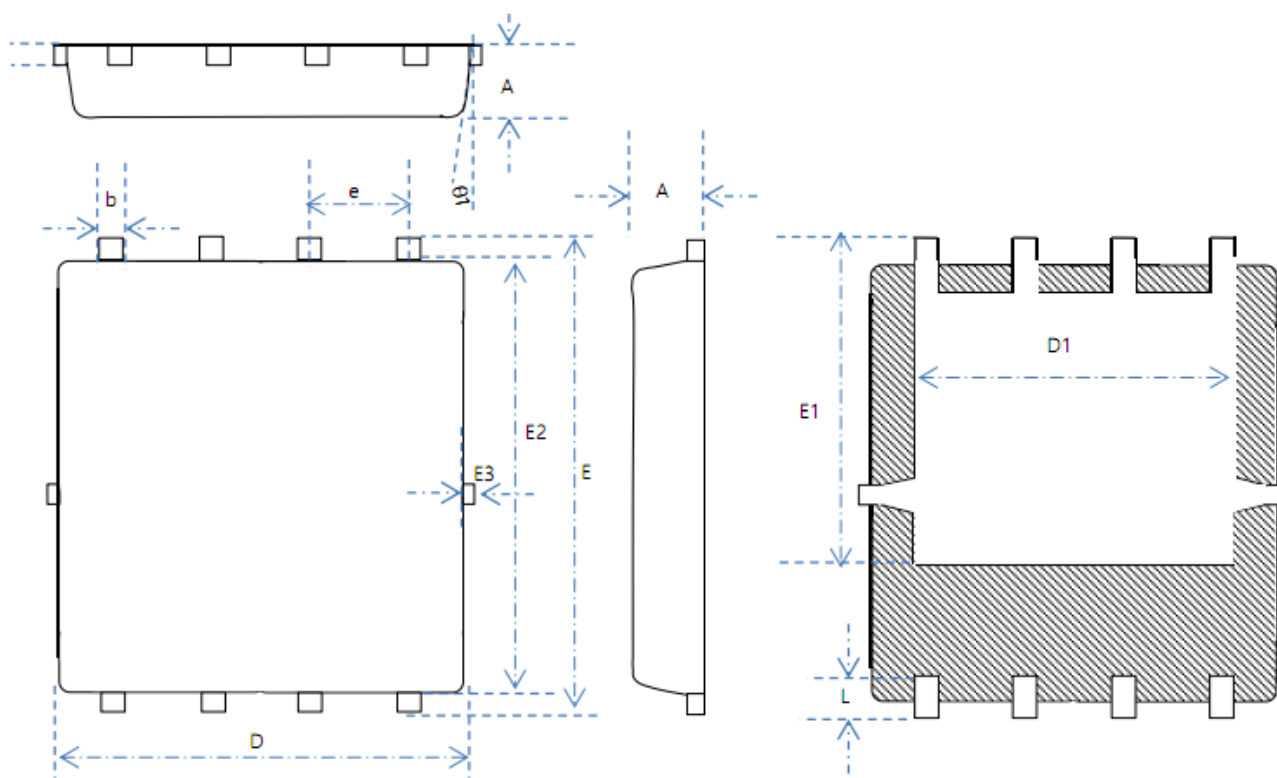


**Unclamped Inductive Switching Test Circuit & Waveforms**



**Peak Diode Recovery dv/dt Test Circuit & Waveforms**





SYMBOL	Mechanical Dimensions/mm			SYMBOL	Mechanical Dimensions/mm		
	MIN	NOM	MAX		MIN	NOM	MAX
A	0.85	0.95	1.05	D	5.10	5.20	5.30
A1	0.254 REF			e	1.270 TYPE		
b	-	0.30	-	D1	3.90	4.0	4.10
E	5.85	6.05	6.25	L	0.54	0.64	0.74
E1	3.90	4.10	4.30				
E2	5.45	5.55	5.65	$\theta 1$	8°	10°	12°
E3	-	-	0.15				



## X-ON Electronics

Largest Supplier of Electrical and Electronic Components

*Click to view similar products for [MOSFET](#) category:*

*Click to view products by [SLKORMICRO](#) manufacturer:*

Other Similar products are found below :

[IRFD120](#) [JANTX2N5237](#) [2SK2267\(Q\)](#) [BUK455-60A/B](#) [TK100A10N1,S4X\(S](#) [MIC4420CM-TR](#) [VN1206L](#) [NDP4060](#) [SI4482DY](#)  
[IRS2092STRPBF-EL](#) [IPS70R2K0CEAKMA1](#) [TK31J60W5,S1VQ\(O](#) [TK31J60W,S1VQ\(O](#) [TK16J60W,S1VQ\(O](#) [2SK2614\(TE16L1,Q\)](#)  
[DMN1017UCP3-7](#) [EFC2J004NUZTDG](#) [P85W28HP2F-7071](#) [DMN1053UCP4-7](#) [NTE2384](#) [DMC2700UDMQ-7](#) [DMN2080UCB4-7](#)  
[DMN61D9UWQ-13](#) [US6M2GTR](#) [DMN31D5UDJ-7](#) [DMP22D4UFO-7B](#) [IPS60R3K4CEAKMA1](#) [DMN1006UCA6-7](#) [DMN16M9UCA6-7](#)  
[STF5N65M6](#) [IRF40H233XTMA1](#) [STU5N65M6](#) [DMN6022SSD-13](#) [DMN13M9UCA6-7](#) [DMTH10H4M6SPS-13](#) [IPS60R360PFD7SAKMA1](#)  
[DMN2990UFB-7B](#) [SSM3K35CT,L3F](#) [IPLK60R1K0PFD7ATMA1](#) [2N7002W-G](#) [MCAC30N06Y-TP](#) [IPWS65R035CFD7AXKSA1](#)  
[MCQ7328-TP](#) [SSM3J143TU,LXHF](#) [DMN12M3UCA6-7](#) [PJMF280N65E1\\_T0\\_00201](#) [PJMF380N65E1\\_T0\\_00201](#)  
[PJMF280N60E1\\_T0\\_00201](#) [PJMF600N65E1\\_T0\\_00201](#) [PJMF900N65E1\\_T0\\_00201](#)