

1A Adjustable / Fixed Low Dropout Linear Regulator

General Description

The SL1117 is a series of low dropout voltage regulators which can provide up to 1A of output current. The SL1117 is available in six fixed voltage, 1.2, 1.8, 2.5, 3.3 and 5.0V. Additionally it is also available in adjustable version. On chip precision trimming adjusts the reference/ output voltage to within $\pm 2\%$. On-chip thermal limiting provides protection against any combination of overload and ambient temperatures that would create excessive junction temperatures.

The SL1117 series is available in SOT-223, TO-252, SOT89 packages. A minimum of 10uF tantalum capacitor is required at the output to improve the transient response and stability.

Features

- ◆ Low Dropout Voltage
- ◆ Load regulation:0.5% Max
- ◆ Optimized for Low Voltage
- ◆ On-chip thermal limiting.
- ◆ Maximum Input Voltage : 18V
- ◆ Adjustable Output Voltage or Fixed 1.2V, 1.8V,2.5V, 3.3V, 5V
- ◆ Standard SOT-223,TO-252 ,SOT89 Packages

Applications

- ◆ Post Regulator for switching DC/DC Converter
- ◆ High Efficiency Linear Regulator
- ◆ Battery Chargers
- ◆ PC Add on Card
- ◆ Motherboard clock supplies
- ◆ LCD Monitor
- ◆ Set-top Box

Block Diagram

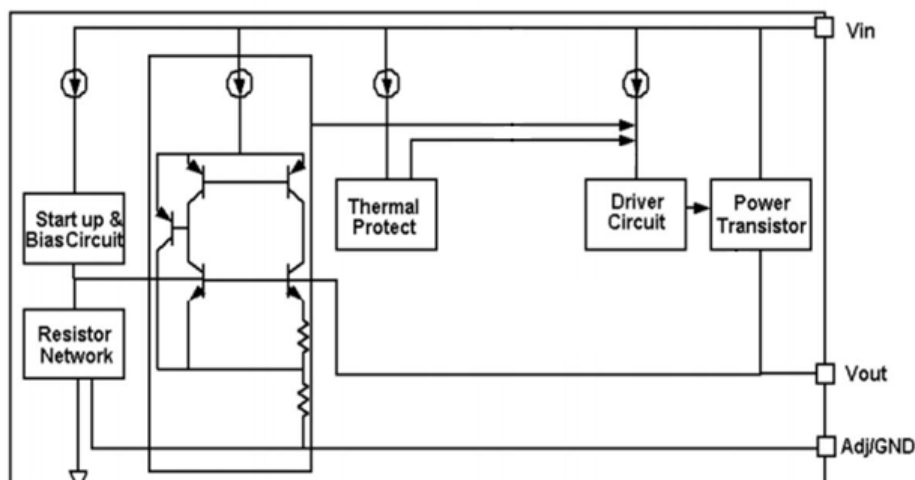

Pin Description

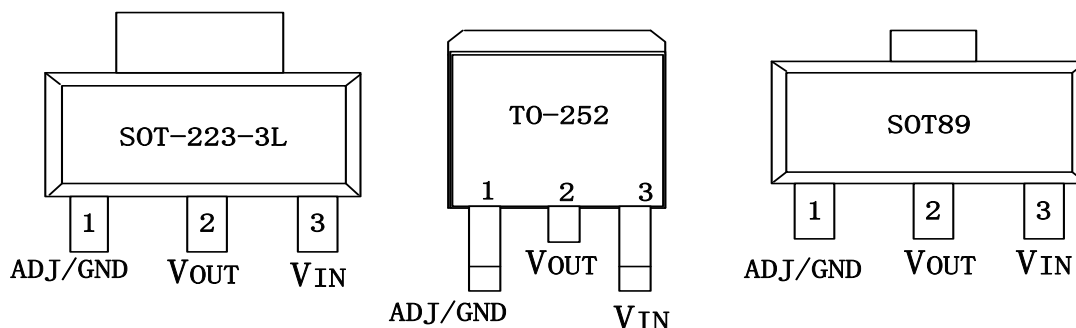

Absolute Maximum Ratings

Symbol	Description	Max	Units
V_{IN}	Input Voltage	18	V
I_{OUT}	DC Output Current	$PD/(V_{IN}-V_{OUT})$	mA
T_J	Operating Junction Temperature Range	-40 to 125	°C
θ_{JA}	Thermal Resistance (SOT-223)	135	°C/W
θ_{JA}	Thermal Resistance (TO-252)	100	°C/W
θ_{JA}	Thermal Resistance (SOT89)	200	°C/W
P_D	Maximum Power Dissipation (SOT-223)	750	mW
P_D	Maximum Power Dissipation (TO-252)	1000	mW
P_D	Maximum Power Dissipation (SOT89)	500	mW

Notes:

Instant maximum ratings specified will not cause permanent damage to the product, while long maximum ratings specified applied will do and may affect product reliability.

Recommended working conditions

Symbol	Description	Max	Units
V_{IN}	Input Voltage	18	V
I_{OUT}	DC Output Current (SOT-223)	600	mA
	DC Output Current (TO-252)	900	mA
	DC Output Current (SOT89)	300	mA

Electrical Characteristics ($V_{in} = <7V$, $T_j = 25^\circ C$ unless otherwise Specified. The ~ denotes specifications which apply over the specified operating temperature range.)

Parameter	Conditions	Min.	Typ.	Max.	Units
Reference voltage	$V_{IN} = V_{OUT} + 2V$, $10mA \leq I_{OUT} \leq 1A$ SL1117 -ADJ	1.225(-2%)	1.250	1.275(+2%)	V
Output voltage	$10mA \leq I_{OUT} \leq 1A$, $V_{IN} = V_{OUT} + 2V$				V
	SL1117 -1.2	1.176	1.20	1.224	
	SL1117 -1.8	1.764	1.80	1.836	
	SL1117 -2.5	2.450	2.50	2.550	
	SL1117 -3.3	3.234	3.30	3.366	
SL1117 -5.0	4.90	5.0	5.10		
Line regulation ^{1,2}	$(V_{OUT} + 1.5V) \leq V_{IN} \leq 12V$, $I_{OUT} = 10mA$		0.15	0.30	%
Load regulation ^{1,2}	$(V_{IN} - V_{OUT}) = 2V$, $10mA \leq I_{OUT} \leq 1A$		0.20	0.50	%
Dropout voltage	$DV_{REF} = 1\%$, $I_{OUT} = 1A$		1.30	1.40	V
Current limit	$(V_{IN} - V_{OUT}) = 2V$	1.2			A
Adjust pin current	SL1117 -ADJ $1.5V \leq (V_{IN} - V_{OUT}) \leq 7V$, $10mA \leq I_{OUT} \leq 1A$		50	120	μA
Minimum load current	$1.5V \leq (V_{IN} - V_{OUT}) \leq 12V$		3	10	mA
Quiescent current	$V_{IN} = V_{OUT} + 1.25V$		3	10	mA
Ripple rejection	$f = 120Hz$, $C_{OUT} = 22\mu F$ Tantalum, $(V_{IN} - V_{OUT}) = 3V$, $I_{OUT} = 1A$	60	70		dB
Thermal regulation	$T_A = 25^\circ C$, 30ms pulse		0.008	0.04	%/W
Temperature stability			0.5		%
Long-term stability	$T_A = 125^\circ C$, 1000hrs.		0.3	1.0	%
RMS output noise (%of V_{OUT})	$T_A = 25^\circ C$, $10Hz \leq f \leq 10kHz$		0.003		%
Thermal resistance, junction to case	SOT-223		15		$^\circ C / W$
	TO-252		10		$^\circ C / W$
	SOT89		20		$^\circ C / W$
Thermal shutdown	Junction temperature		150		$^\circ C$
Thermal shutdown hysteresis			10		$^\circ C$

1. See thermal regulation specifications for changes in output voltage due to heating effects. Load and line regulation are measured at a constant junction temperature by low duty cycle pulse testing.
2. Line and load regulation are guaranteed up to the maximum power dissipation (1.2W). Power dissipation is determined by input/output differential and the output current. Guaranteed maximum output power will not be available over the full input/ output voltage range.
3. Output current must be limited to meet the absolute maximum ratings of the part.

Typical Performance Characteristics (TA=25°C, unless otherwise noted.)

Line regulation
SL1117-ADJ Vout Vs. Vin

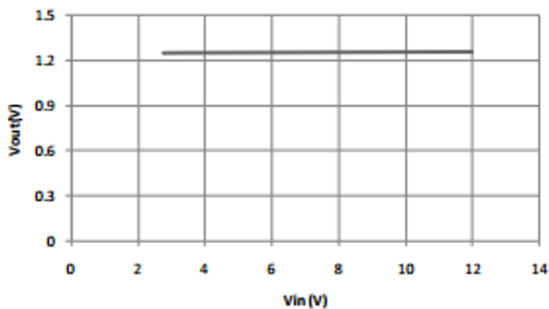

Dropout Voltage
SL1117 Dropout Voltage

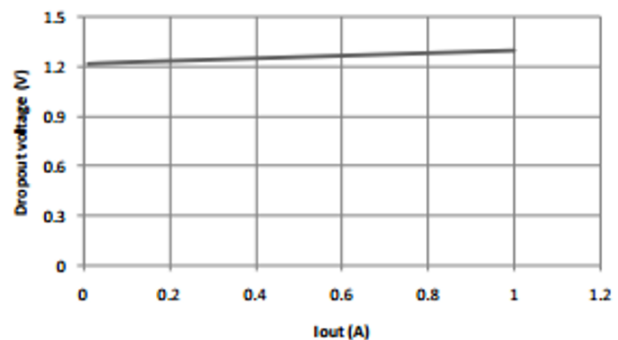

Load regulation
SL1117 -ADJ Vout Vs. Iout

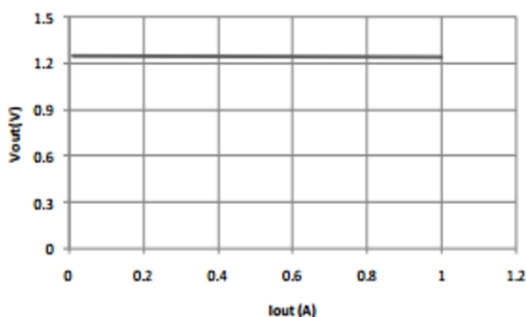

Thermal performance with OTP
SL1117 Thermal performance with OTP

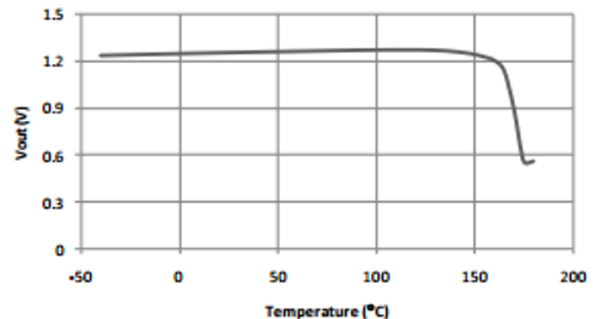

Application Information

Output voltage adjustment

The SL1117 regulates the output by comparing the output voltage to an internally generated reference voltage. On the adjustable version as shown in Fig.1, the VREF is available externally as 1.25V between VOUT and ADJ. The voltage ratio formed by R1 and R2 should be set to conduct 10mA (minimum output load).

The output voltage is given by the following equation:

$$V_{OUT} = V_{REF} (1 + R2/R1) + I_{ADJ} \times R2$$

On fixed versions of SL1117, the voltage divider is provided internally.

Figure 1. Basic Adjustable Regulator

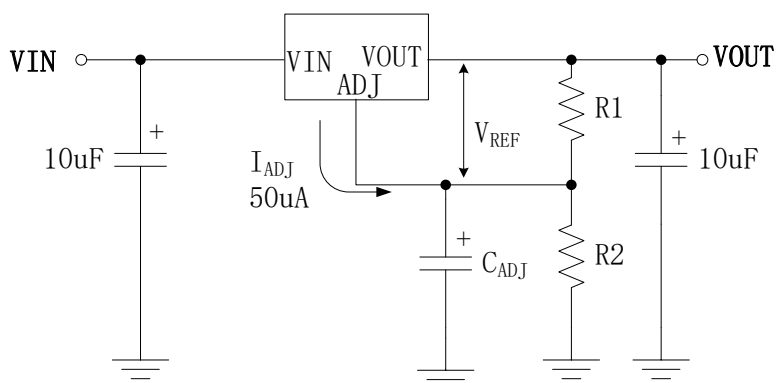

Input Bypass Capacitor

An input capacitor is recommended. A 10µF tantalum on the input is a suitable input bypassing for almost all applications.

Adjust Terminal Bypass Capacitor

The adjust terminal can be bypassed to ground with a bypass capacitor (CADJ) to improve ripple rejection. This bypass capacitor prevents ripple from being amplified as the output voltage is increased. At any ripple frequency, the impedance of the CADJ should be less than R1 to prevent the ripple from being amplified:

$$(2\pi * f_{RIPPLE} * C_{ADJ}) < R1$$

The R1 is the resistor between the output and the adjust pin. Its value is normally in the range of 100-200Ω.

Output Capacitor

SL1117 requires a capacitor from VOUT to GND to provide compensation feedback to the internal gain stage. This is to ensure stability at the output terminal. Typically, a 10µF tantalum or 50µF aluminum electrolytic is sufficient.

Note: It is important that the ESR for this capacitor does not exceed 0.5 Ω.

The output capacitor does not have a theoretical upper limit and increasing its value will increase stability. COUT = 100µF or more is typical for high current regulator design. example, with R1 = 124Ω and fRIPPLE = 120Hz, the CADJ should be > 11µF.

Load Regulation

When the adjustable regulator is used (Fig.2), the best load regulation is accomplished when the top of the resistor divider (R1) is connected directly to the output pin of the SL1117. When so connected, R_P is not multiplied by the divider ratio. For Fixed output version, the top of R1 is internally connected to the output and ground pins can be connected to low side of the load.

Figure 2. Best Load Regulation Using Adjustable Output Regulator

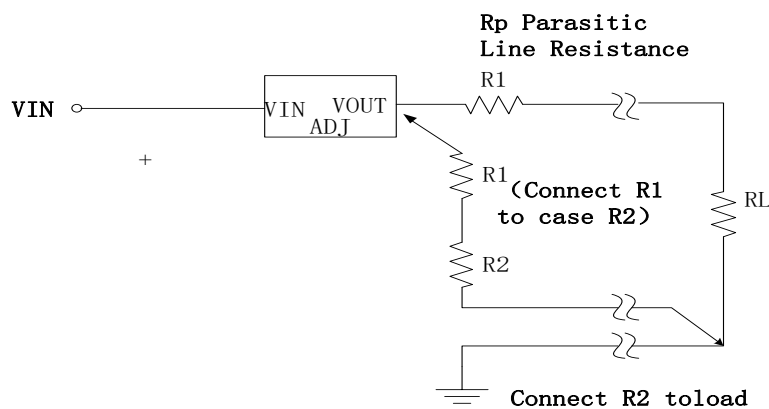

Thermal Protection

SL1117 has thermal protection which limits junction temperature to 150°C. However, device functionality is only guaranteed to a maximum junction temperature of +125°C. The power dissipation and junction temperature for SL1117 in DPAK package are given by

$$PD = (V_{IN} - V_{OUT}) * I_{out}$$

$$T_{JUNCTION} = T_{AMBIENT} + (P_D * \theta_{JA})$$

Note: TJUNCTION must not exceed 125°C

Thermal Consideration

The SL1117 series contain thermal limiting circuitry designed to protect itself from over-temperature conditions. Even for normal load conditions, maximum junction temperature ratings must not be exceeded. As mention in thermal protection section, we need to consider all sources of thermal resistance between junction and ambient. It includes junction-to case, case-to-heat-sink interface, and heat sink thermal resistance itself.

Junction-to-case thermal resistance is specified from the IC junction to the bottom of the case

directly below the die. Proper mounting is required to ensure the best possible thermal flow from this area of the package to the heat sink. The case of all devices in this series is electrically connected to the output. Therefore, if the case of the device must be electrically isolated, a thermally conductive spacer is recommend.

PACKAGE DESCRIPTION

SOT-223 PACKAGE OUTLINE DIMENSIONS

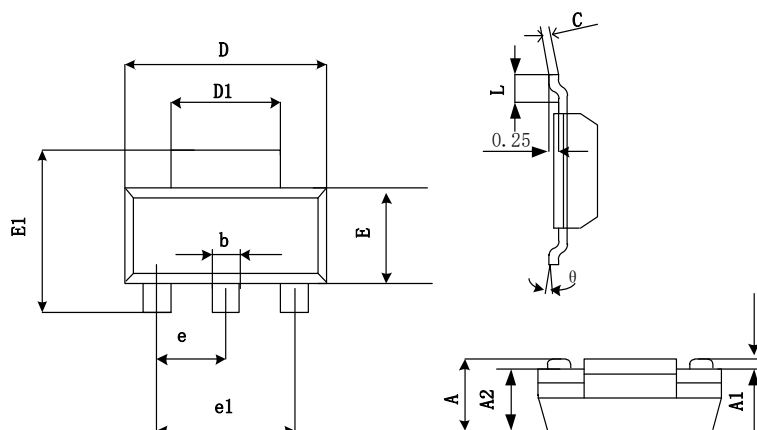

Symbol	Dimensions In Millimeters		Dimensions In Inches	
	Min	Max	Min	Max
A	1.520	1.800	0.060	0.071
A	0.020	0.130	0.001	0.005
A	1.500	1.700	0.059	0.067
b	0.660	0.840	0.026	0.033
c	0.230	0.350	0.009	0.014
D	6.450	6.850	0.254	0.270
D	2.900	3.000	0.114	0.122
E	3.450	3.850	0.136	0.152
E	6.830	7.070	0.269	0.278
e	2.300 (BSC)		0.091(BSC)	
e	4.500	4.700	0.177	0.185
L	0.900	1.150	0.035	0.045
θ	10°		10	

TO-252-2L PACKAGE OUTLINE DIMENSIONS

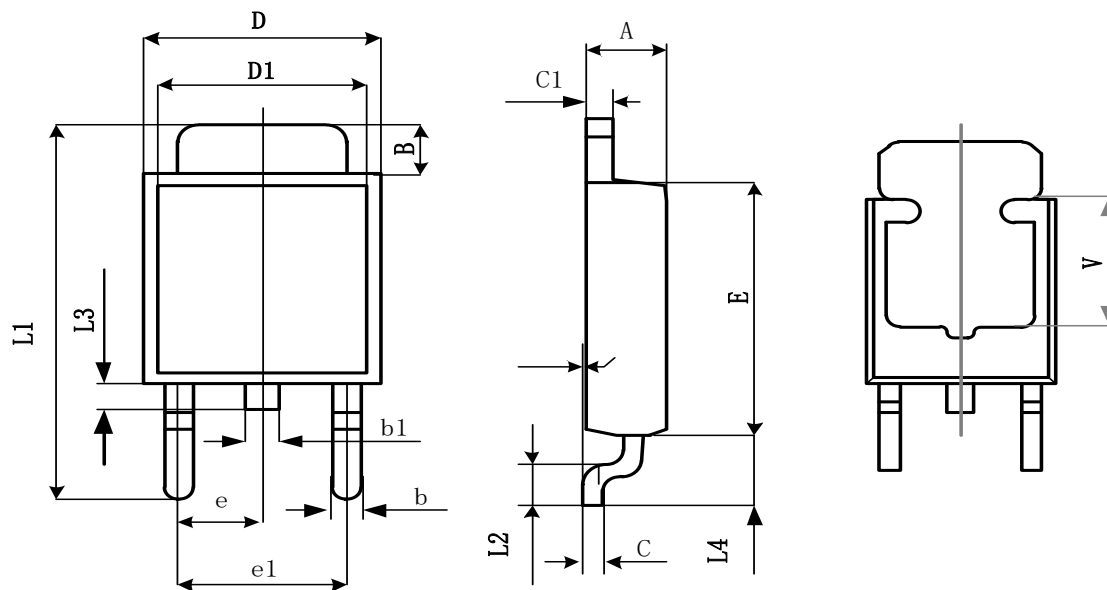

Symbol	Dimensions In Millimeters		Dimensions In Inches	
	Min	Max	Min	Max
A	2.200	2.400	0.087	0.094
A1	0.000	0.127	0.000	0.005
B	1.200	1.650	0.047	0.065
b	0.500	0.810	0.020	0.032
b1	0.700	0.900	0.028	0.035
c	0.460	0.580	0.018	0.023
c1	0.430	0.580	0.014	0.023
D	6.350	6.700	0.250	0.264
D1	5.200	5.400	0.205	0.213
E	5.400	6.200	0.213	0.244
e	2.300TYP		0.0901TYP	
e1	4.500	4.700	0.177	0.185
L1	9.500	9.900	0.374	0.390
L2	0.950	1.600	0.037	0.063
L3	0.700	1.100	0.028	0.043
L4	2.550	2.900	0.100	0.114
V	3.80REF		0.150REF	

SOT89 PACKAGE OUTLINE DIMENSIONS

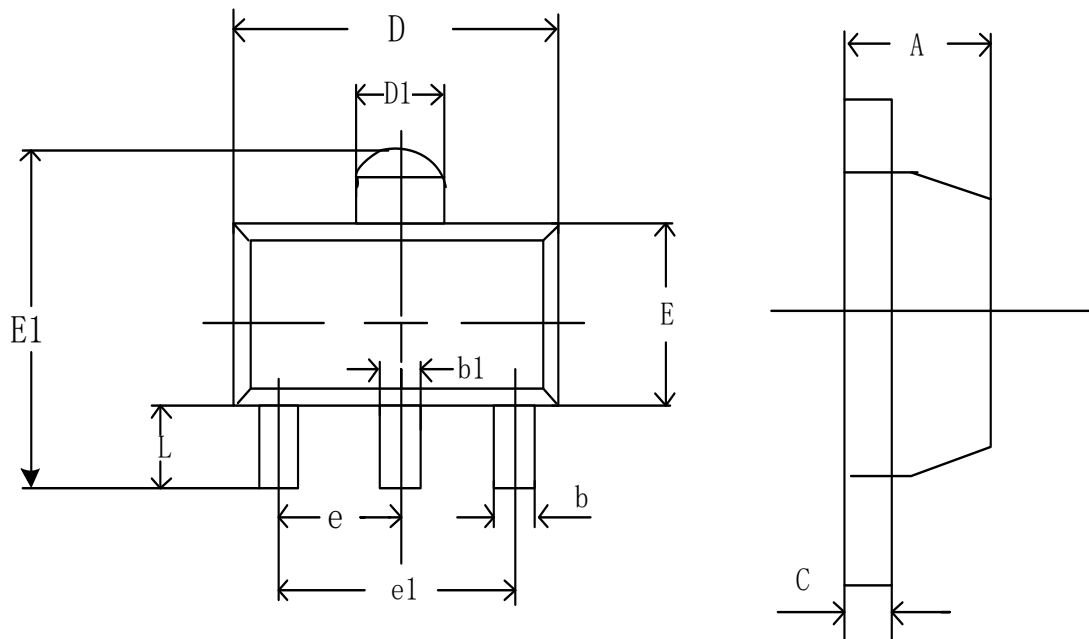

Symbol	Dimensions In Millimeters		Dimensions In Inches	
	Min	Max	Min	Max
A	1.400	1.600	0.055	0.063
b	0.350	0.520	0.013	0.197
b	0.400	0.580	0.016	0.023
c	0.350	0.450	0.014	0.018
D	4.400	4.600	0.173	0.181
D	1.550	1.750	0.061	0.069
E	2.350	2.600	0.091	0.102
E	3.720	4.530	0.146	0.178
e	1.500TYP		0.060TYP	
e	3.000TYP		0.118TYP	
L	0.820	1.100	0.032	0.047

X-ON Electronics

Largest Supplier of Electrical and Electronic Components

Click to view similar products for [LDO Voltage Regulators](#) category:

Click to view products by [SLKORMICRO](#) manufacturer:

Other Similar products are found below :

[AP7363-SP-13](#) [NCV8664CST33T3G](#) [L79M05TL-E](#) [AP7362-HA-7](#) [PT7M8202B12TA5EX](#) [TCR3DF185,LM\(CT](#) [TLF4949EJ](#)
[NCP4687DH15T1G](#) [NCV8703MX30TCG](#) [LP2951CN](#) [NCV4269CPD50R2G](#) [AP7315-25W5-7](#) [NCV47411PAAJR2G](#) [AP2111H-1.2TRG1](#)
[ZLDO1117QK50TC](#) [AZ1117ID-ADJTRG1](#) [NCV4263-2CPD50R2G](#) [NCP114BMX075TCG](#) [MC33269T-3.5G](#) [TLE4471GXT](#) [AP7315-33SA-](#)
[7](#) [NCV4266-2CST33T3G](#) [NCP715SQ15T2G](#) [NCV8623MN-50R2G](#) [NCV563SQ18T1G](#) [NCV8664CDT33RKG](#) [NCV4299CD250R2G](#)
[NCP715MX30TBG](#) [NCV8702MX25TCG](#) [L974113TR](#) [TLE7270-2E](#) [NCV562SQ25T1G](#) [AP2213D-3.3TRG1](#) [AP2202K-2.6TRE1](#)
[NCV8170BMX300TCG](#) [NCV8152MX300180TCG](#) [NCP700CMT45TBG](#) [AP7315-33W5-7](#) [LD56100DPU28R](#) [NCP154MX180300TAG](#)
[AP2210K-3.0TRE1](#) [AP2113AMTR-G1](#) [NJW4104U2-33A-TE1](#) [MP2013AGG-5-P](#) [NCV8775CDT50RKG](#) [NJM2878F3-45-TE1](#) [S-](#)
[19214B00A-V5T2U7](#) [S-19214B50A-V5T2U7](#) [S-19213B50A-V5T2U7](#) [S-19214BC0A-E8T1U7*1](#)