

200V Half-Bridge Driver

PRODUCT SUMMARY

- V_{OFFSET} 200 V max.
- $I_{\text{O+/- (min)}}$ 130 mA/270 mA
- V_{OUT} 10 V - 20 V
- $t_{\text{on/off (typ.)}}$ 680 ns/150 ns
- **Deadtime (typ.)** 520 ns

GENERAL DESCRIPTION

The SL2003 is a high voltage, high speed power MOSFET and IGBT drivers with dependent high- and low-side referenced output channels. Proprietary HVIC and latch immune CMOS technologies enable ruggedized monolithic construction. The logic input is compatible with standard CMOS or LSTTL output, down to 3.3 V logic. The output drivers feature a high pulse current buffer stage designed for minimum driver cross conduction. The floating channel can be used to drive an N-channel power MOSFET or IGBT in the high-side configuration which operates up to 200 V.

FEATURES

- Floating channel designed for bootstrap operation
- Fully operational to +200 V
- Tolerant to negative transient voltage, dV/dt immune
- Gate drive supply range from 10 V to 20 V
- Undervoltage lockout
- 3.3 V, 5 V, and 15 V logic compatible
- Cross-conduction prevention logic
- Matched propagation delay for both channels
- Internal set deadtime
- High-side output in phase with HIN input
- Low-side output out of phase with LIN input
- RoHS compliant
- SOP8 package

TYPICAL APPLICATION CIRCUIT

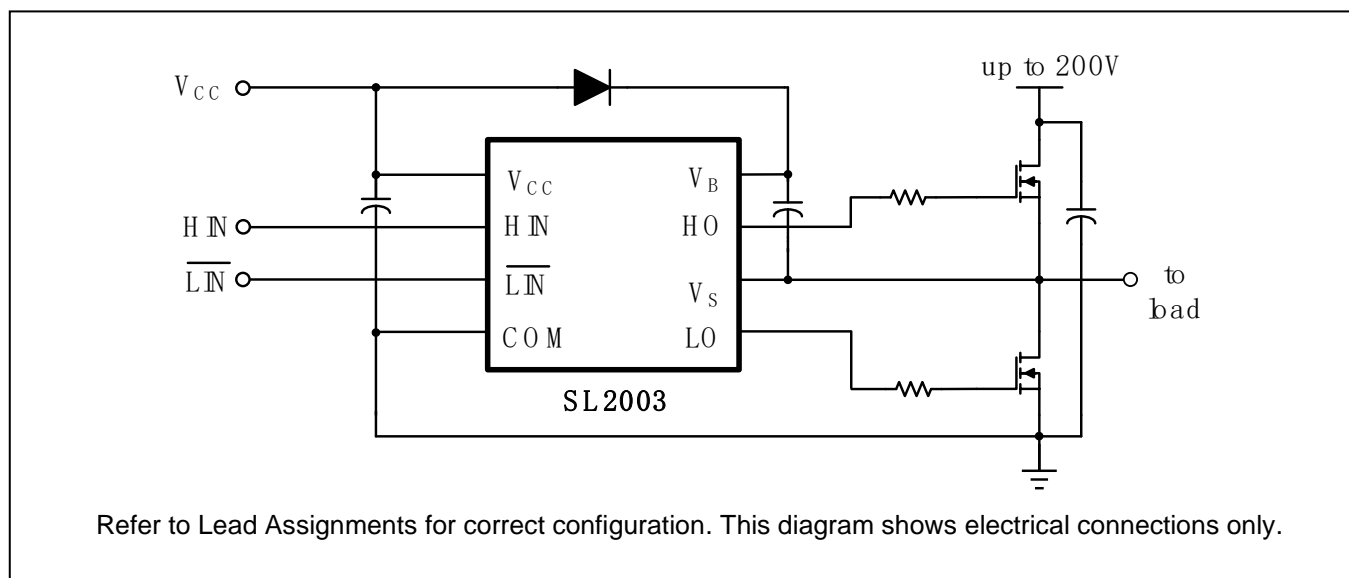

PIN CONFIGURATION

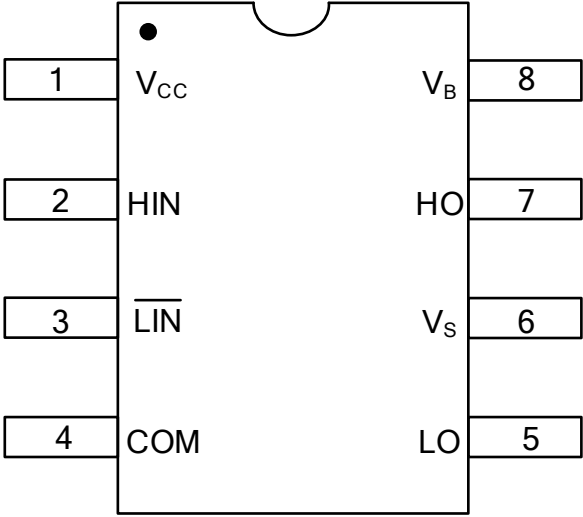
Package	Pin Configuration (Top View)
SOP8	

PIN DESCRIPTION

No.	Pin	Description
1	V _{CC}	Low-side and logic fixed supply
2	HIN	Logic input for high-side gate driver output (HO), in phase
3	$\overline{\text{LIN}}$	Logic input for low-side gate driver output (LO), out of phase
4	COM	Low-side return
5	LO	Low-side gate drive output
6	V _S	High-side floating supply return
7	HO	High-side gate drive output
8	V _B	High-side floating supply

ORDERING INFORMATION

Industrial Range: -40°C to +125°C

Order Part No.	Package	QTY
SL2003	SOP8, Pb-Free	2500/Reel

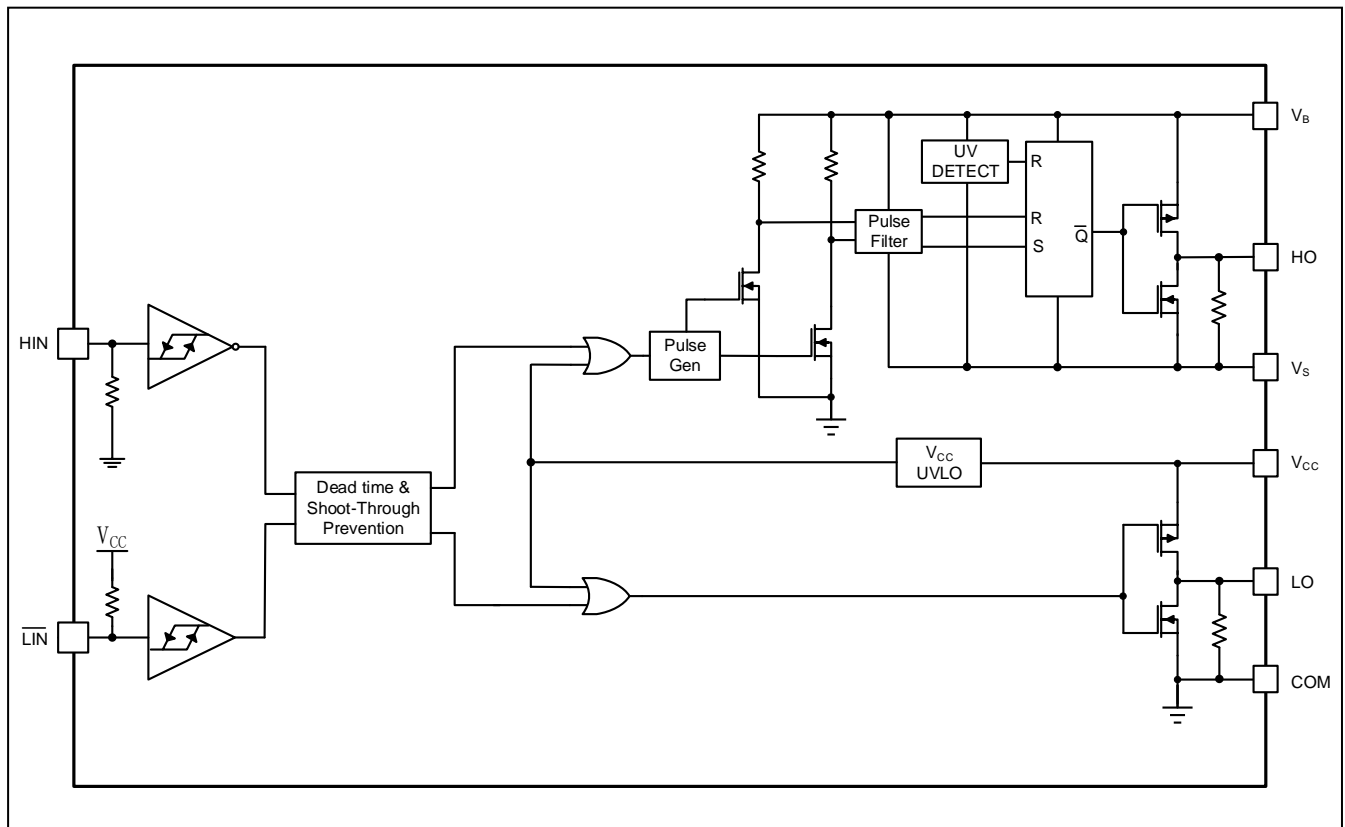
FUNCTIONAL BLOCK DIAGRAM

ABSOLUTE MAXIMUM RATINGS

Symbol	Definition	Min.	Max.	Units
V _B	High-side floating absolute voltage	-0.3	225	V
V _S	High-side floating supply offset voltage	V _B - 25	V _B + 0.3	
V _{HO}	High-side floating output voltage	V _S - 0.3	V _B + 0.3	
V _{CC}	Low-side and logic fixed supply voltage	-0.3	25	
V _{LO}	Low-side output voltage	-0.3	V _{CC} + 0.3	
V _{IN}	Logic input voltage (HIN & $\overline{\text{LIN}}$)	-0.3	V _{CC} + 0.3	
dV _S /dt	Allowable offset supply voltage transient	---	50	V/ns
P _D	Package power dissipation @ T _A ≤ +25°C	---	0.625	W
θ _{JA}	Thermal resistance, junction to ambient	---	200	°C/W
T _J	Junction temperature	---	150	°C
T _S	Storage temperature	-55	150	
T _L	Lead temperature (soldering, 10 seconds)	---	300	

Note: Absolute maximum ratings indicate sustained limits beyond which damage to the device may occur. All voltage parameters are absolute voltages referenced to COM. The thermal resistance and power dissipation ratings are measured under board mounted and still air conditions.

RECOMMENDED OPERATION CONDITIONS

Symbol	Definition	Min.	Max.	Units
V _B	High-side floating absolute voltage	V _S + 10	V _S + 20	V
V _S	High-side floating supply offset voltage		200	
V _{HO}	High-side floating output voltage	V _S	V _B	
V _{CC}	Low-side and logic fixed supply voltage	10	20	
V _{LO}	Low-side output voltage	0	V _{CC}	
V _{IN}	Logic input voltage (HIN & $\overline{\text{LIN}}$)	0	V _{CC}	
T _A	Ambient temperature	- 40	125	°C

Note: The input/output logic timing diagram is shown in Figure 1. For proper operation the device should be used within the recommended conditions. The V_S offset rating is tested with all supplies biased at a 15 V differential.

DYNAMIC ELECTRICAL CHARACTERISTICS

V_{BIAS} (V_{CC} , V_{BS}) = 15 V, C_L = 1000 pF and T_A = 25°C unless otherwise specified.

Symbol	Parameter	Condition	Min.	Typ.	Max.	Unit
t_{on}	Turn-on propagation delay	$V_S = 0$ V	---	680	820	ns
t_{off}	Turn-off propagation delay	$V_S = 0$ V	---	150	220	
t_r	Turn-on rise time		---	70	170	
t_f	Turn-off fall time		---	35	90	
DT	Deadtime, LS turn-off to HS turn-on & HS turn-on to LS turn-off		400	520	750	
MT	Delay matching, HS & LS turn-on/off		---	---	60	

STATIC ELECTRICAL CHARACTERISTICS

V_{BIAS} (V_{CC} , V_{BS}) = 15 V and T_A = 25°C unless otherwise specified. The V_{IN} , V_{TH} , and I_{IN} parameters are referenced to COM and are applicable to all logic input leads: HIN and \overline{LIN} . The V_O and I_O parameters are referenced to COM and are applicable to the respective output leads: HO or LO.

Symbol	Parameter	Condition	Min.	Typ.	Max.	Unit
V_{IH}	Logic "1" (HIN) & Logic "0" (\overline{LIN}) input voltage	$V_{CC} = 10$ V to 20V	2.5	---	---	V
V_{IL}	Logic "0" (HIN) & Logic "1" (\overline{LIN}) input voltage		---	---	0.8	
V_{OH}	High level output voltage, $V_{BIAS} - V_O$	$I_O = 2$ mA	---	0.05	0.2	
V_{OL}	Low level output voltage, V_O		---	0.02	0.1	
I_{LK}	Offset supply leakage current	$V_B = V_S = 200$ V	---	---	50	μ A
I_{QBS}	Quiescent V_{BS} supply current	$V_{IN} = 0$ V	---	60	75	
I_{QCC}	Quiescent V_{CC} supply current		---	220	280	
I_{IN+}	Logic "1" input bias current	$HIN = 5$ V, $\overline{LIN} = 0$ V	---	8	15	
I_{IN-}	Logic "0" input bias current	$HIN = 0$ V, $\overline{LIN} = 5$ V	---	---	5	
V_{CCUV+} V_{BSUV+}	V_{CC} and V_{BS} supply undervoltage positive going threshold		8	8.9	9.8	V
V_{CCUV-} V_{BSUV-}	V_{CC} and V_{BS} supply undervoltage negative going threshold		7.4	8.2	9	
I_{O+}	Output high short circuit pulsed current	$V_O = 0$ V, $V_{IN} = V_{IH}$ $PW \leq 10$ μ s	130	290		mA
I_{O-}	Output low short circuit pulsed current	$V_O = 15$ V, $V_{IN} = V_{IL}$ $PW \leq 10$ μ s	270	600		

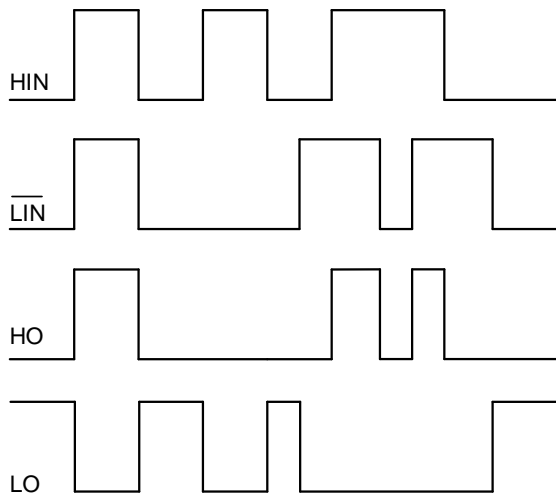

Figure 1. Input/Output Timing Diagram

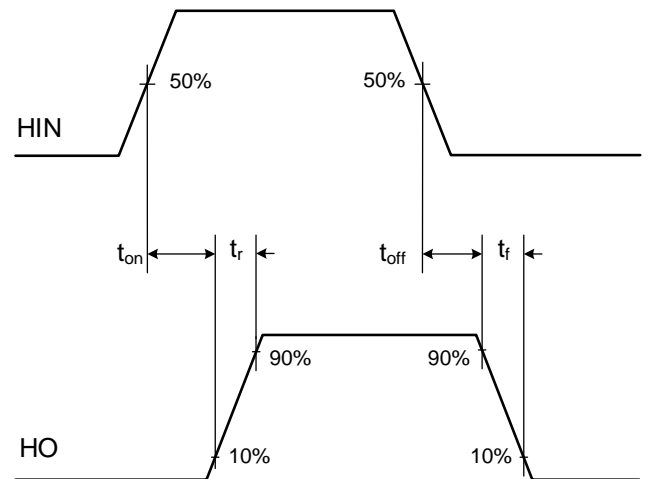

Figure 2. High Side Switching Time Waveform

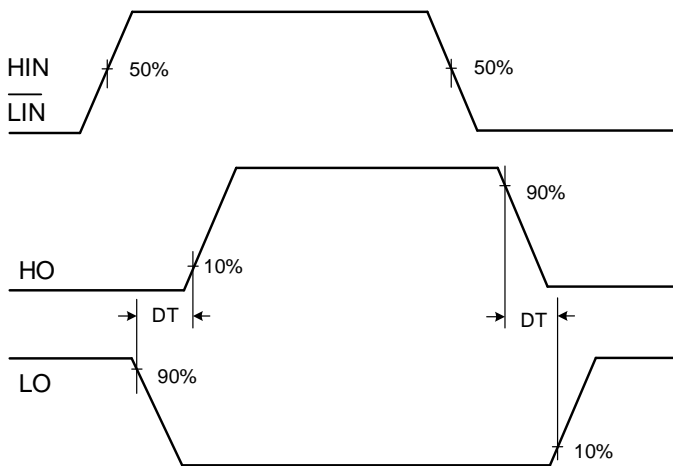

Figure 3. Dead Time Waveform

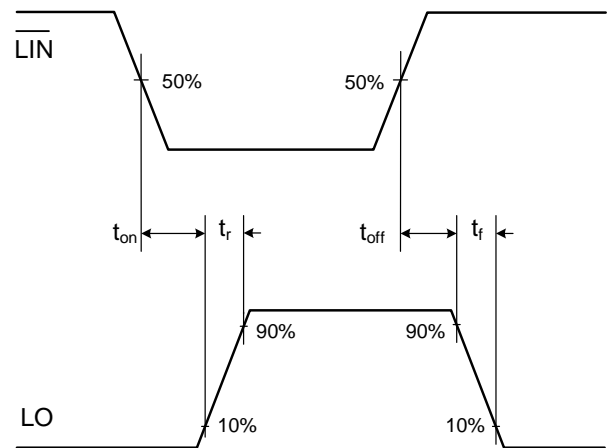

Figure 4. Low Side Switching Time Waveform

PACKAGE CASE OUTLINES

Figure 5. SOP8 Outline Dimensions

X-ON Electronics

Largest Supplier of Electrical and Electronic Components

Click to view similar products for [Gate Drivers](#) category:

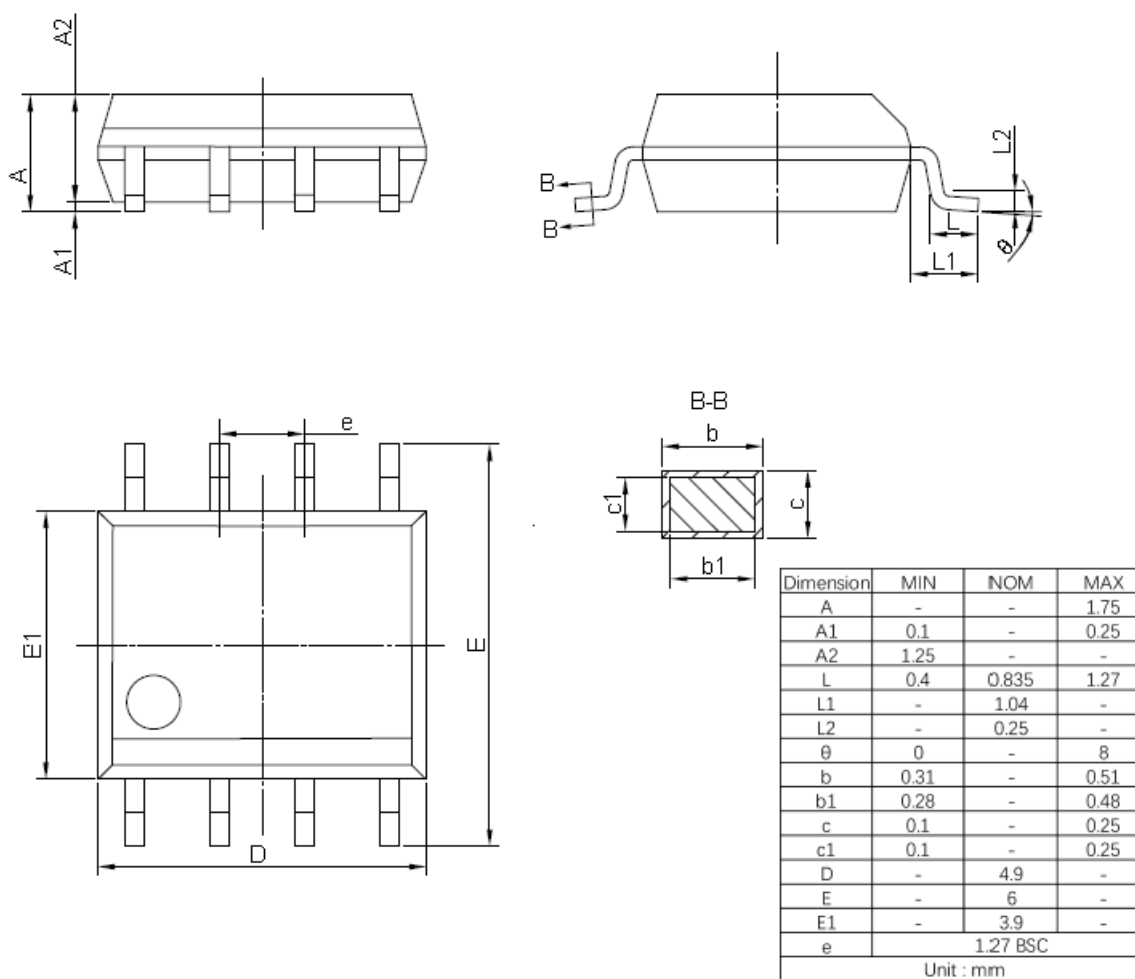
Click to view products by [SLKORMICRO](#) manufacturer:

Other Similar products are found below :

[00053P0231](#) [56956](#) [57.404.7355.5](#) [LT4936](#) [57.904.0755.0](#) [5882900001](#) [00600P0005](#) [5951900000](#) [0131700000](#) [00-2240](#) [LTP70N06](#)
[LVP640](#) [5J0-1000LG-SIL](#) [LY2-US-AC240](#) [LY3-UA-DC24](#) [00576P0020](#) [LZNQ2-US-DC12](#) [LZP40N10](#) [0207100000](#) [0207400000](#)
[60100564](#) [60249-1-CUT-TAPE](#) [0134220000](#) [6035](#) [60713816](#) [M15730061](#) [61161-90](#) [61278-0020](#) [6131-204-23149P](#) [6131-205-17149P](#)
[6131-209-15149P](#) [6131-218-17149P](#) [6131-220-21149P](#) [6131-260-2358P](#) [6131-265-11149P](#) [CS1HCPU63](#) [6150300002](#) [6150-5001](#) [CSK-38-](#)
[60006](#) [CSK-38-60008](#) [621A](#) [622-4053LF](#) [6273](#) [M37730026](#) [M40N08MA-H](#) [M55155/29XH06](#) [64-807](#) [65003](#) [65-1930-6](#) [M82310002](#)