

3.0V-5.5V, 15kV HBM ESD-Protected, 14Mbps Half-Duplex RS485/RS422 Transceiver

FEATURES

- 3.0V~5.5V Wide Power Range, Half-Duplex
- ESD Protection for RS-485 I/O Pins $\pm 15\text{kV}$, Human Body Model
- Bus Fault Tolerance and Withstand Voltage Reach $\pm 15\text{V}$
- 1/8 Unit Load, Allow Up to 256 Transceivers on the Bus
- Driver Short-Circuit Output Protection
- Low Power Off Function
- Receiver Open-Circuit Failure Protection
- Strong Anti-Noise Ability
- Integrated Transient Voltage Suppression Function
- Data transmission up to 14Mbps in an electric noise environment
- Available in SOP8, DIP8, MSOP8/8 μ MAX/VSSOP8 and DFN3*3-8 packages

PRODUCT APPEARANCE

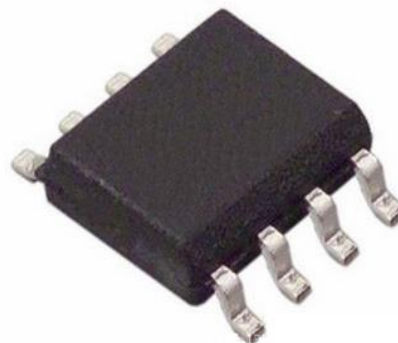

Provide green and environmentally friendly lead-free package

DESCRIPTION

SL3088E is a RS -485 transceiver with 3.0V~5.5V wide power supply, bus port ESD protection capacity of over 15kV HBM, bus withstand voltage range of $\pm 15\text{V}$, half duplex, low power consumption, and fully meet the requirements of TIA / EIA-485 standard.

SL3088E includes a driver and a receiver, both of which can be enabled and closed independently. When both are disabled, both the driver and the receiver output are high resistance state. SL3088E has 1/8 load, which allows 256 SL3088E transceivers to be connected to the same communication bus. It can realize error-free data transmission up to 14Mbps.

SL3088E has a working voltage range of 3.0~5.5V, and has the functions of fail-safe, current-limiting protection, over-voltage protection, etc.

PIN CONFIGURATION

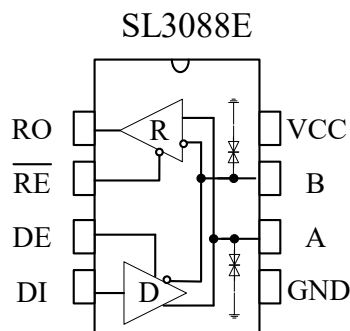

Figure 1 SL3088E Pin Configuration

PIN DESCRIPTION

PIN	SYMBOL	DESCRIPTION
1	RO	Receiver Output. When /RE is low and if $A - B \geq -10\text{mV}$, RO will be high; if $A - B \leq -200\text{mV}$, RO will be low.
2	/RE	Receiver Output Enable. Drive /RE low to enable RO; RO is high impedance when /RE is high. Drive /RE high and DE low to enter low-power shutdown mode.
3	DE	Driver Output Enable. Drive DE high to enable driver outputs. These outputs are high impedance when DE is low. Drive /RE high and DE low to enter low-power shutdown mode.
4	DI	Driver Input. With DE high, a low on DI forces non-inverting output low and inverting output high. Similarly, a high on DI forces non-inverting output high and inverting output low.
5	GND	Ground.
6	A	non-inverting Receiver Input and non-inverting Driver Output.
7	B	Inverting Receiver Input and Inverting Driver Output
8	VCC	Positive Supply.

LIMITING VALUES

PARAMETER	SYMBOL	VALUE	UNIT
Supply Voltage	VCC	+6.5	V
Control Input Voltage	/RE, DE, DI	-0.3~VCC+0.5	V
Receiver Input Voltage	A, B	-15~+15	V
Receiver Output Voltage	RO	-0.3~VCC+0.5	V
Operating Temperature Ranges	T _A	-40~125	°C
Storage Temperature Range	T _{stg}	-60~150	°C
Lead Temperature		300	°C
Continuous Power Dissipation	SOP8	470	mW
	MSOP8	830	mW
	DIP8	700	mW

The maximum limit parameters mean that exceeding these values may cause irreversible damage to the device. Under these conditions, it is not conducive to the normal operation of the device. The continuous operation of the device at the maximum allowable rating may affect the reliability of the device. The reference point for all voltages is ground.

DRIVER DC ELECTRICAL CHARACTERISTICS

PARAMETER	SYMBOL	CONDITION	MIN.	TYP.	MAX.	UNIT
Differential Driver Output (No load)	V_{OD1}		3		5.5	V
Differential Driver Output	V_{OD2}	Figure 2 , $R_L = 54 \Omega$, $V_{CC}=3.3V$	1.5		V_{CC}	V
		Figure 2 , $R_L = 54 \Omega$, $V_{CC}=5V$	1.5		V_{CC}	
Change in Magnitude of Driver Differential Output Voltage (NOTE1)	ΔV_{OD}	Figure 2 , $R_L = 54 \Omega$			0.2	V
Driver Common-Mode Output Voltage	V_{OC}	Figure 2 , $R_L = 54 \Omega$			3	V
Change in Magnitude of Common-Mode Output Voltage (NOTE1)	ΔV_{OC}	Figure 2 , $R_L = 54 \Omega$			0.2	V
Input High Voltage	V_{IH}	DE, DI, /RE	2.0			V
Input Low Voltage	V_{IL}	DE, DI, /RE			0.8	V
Logic Input Current	I_{IN1}	DE, DI, /RE	-2		2	μA
Output Short-circuit Current, Short-circuit to High	I_{OSD1}	short-circuit to 0V~12V			250	mA
Output Short-circuit Current, Short-circuit to Low	I_{OSD2}	short-circuit to -7V~0V	-250			mA

(Unless otherwise noted, $Temp=T_{MIN} \sim T_{MAX}$, $Temp=25^{\circ}C$).

NOTE1: ΔV_{OD} and ΔV_{OC} are the changes in V_{OD} and V_{OC} , respectively, when the DI input changes state.

RECEIVER DC ELECTRICAL CHARACTERISTICS

PARAMETER	SYMBOL	CONDITION	MIN.	TYP.	MAX.	UNIT
Input Current (A, B)	I_{IN2}	DE = 0 V, $V_{CC}=0$ or 3.3/5V $V_{IN} = 12 V$			125	μA

PARAMETER	SYMBOL	CONDITION	MIN.	TYP.	MAX.	UNIT
Input Current (A, B)	I_{IN2}	DE = 0 V, VCC=0 or 3.3/5V $V_{IN} = -7$ V	-100			μ A
Positive Input Threshold Voltage	V_{IT+}	$-7V \leq V_{CM} \leq 12V$			-10	mV
Reverse Input Threshold Voltage	V_{IT-}	$-7V \leq V_{CM} \leq 12V$	-200			mV
Input Hysteresis Voltage	V_{hys}	$-7V \leq V_{CM} \leq 12V$	10	30		mV
Receiver Output High Voltage	V_{OH}	$I_{OUT} = -2.5mA$, $V_{ID} = +200$ mV	VCC-1.5			V
Receiver Output Low Voltage	V_{OL}	$I_{OUT} = +2.5mA$, $V_{ID} = -200$ mV			0.4	V
Three-State Output Current at Receiver	I_{OZR}	$0.4V < V_O < 2.4V$			± 1	μ A
Receiver Input Resistance	R_{IN}	$-7V \leq V_{CM} \leq 12V$	96			k Ω
Receiver Short-Circuit Output Current	I_{OSR}	$0 V \leq V_O \leq VCC$	± 8		± 90	mA

(Unless otherwise noted, Temp= T_{MIN} ~ T_{MAX} , Temp=25°C).

SUPPLY CURRENT

PARAMETER	SYMBOL	CONDITION	MIN.	TYP.	MAX.	UNIT
Supply Current	I_{CC1}	/RE=0V, DE = 0 V, VCC=3.3V		240	650	μ A
		/RE=0V, DE = 0 V VCC=5V		270	750	μ A
	I_{CC2}	/RE=VCC, DE=VCC, VCC=3.3V		250	650	μ A
		/RE=VCC, DE=VCC, VCC=5V		280	750	μ A
Shutdown Current	I_{SHDN}	/RE=VCC, DE=0V, VCC=3.3V		0.2	10	μ A
		/RE=VCC, DE=0V, VCC=5V		0.2	10	μ A

DRIVER SWITCHING CHARACTERISTICS

PARAMETER	SYMBOL	CONDITION	MIN.	TYP.	MAX.	UNIT
Driver Differential Output Delay	t_{DD}	$R_L = 60\Omega$, $C_L = 100\text{pF}$, Figure 3 & Figure 4		20	40	ns
Driver Differential Output Transition Time	t_{TD}			12	28	ns
Drive Propagation Delay from Low to High	t_{PLH}	$R_L = 27\Omega$, Figure 3 & Figure 4		20	40	ns
Drive Propagation Delay from High to Low	t_{PHL}			20	40	ns
$ t_{PLH} - t_{PHL} $	t_{PDS}			1	8	ns
Driver Enable to Output High	t_{PZH}	$R_L = 110\Omega$, Figure 5 & Figure 6			55	ns
Driver Enable to Output Low	t_{PZL}				55	ns
Driver Disable Time from Low	t_{PLZ}	$R_L = 110\Omega$, Figure 5 & Figure 6			85	ns
Driver Disable Time from High	t_{PHZ}				85	ns
In Shutdown mode, Enable to Output High	t_{DSH}	$R_L = 110\Omega$, Figure 5 & Figure 6		20	100	ns
In Shutdown mode, Enable to Output Low	t_{DSL}	$R_L = 110\Omega$, Figure 5 & Figure 6		20	100	ns

RECEIVER SWITCHING CHARACTERISTICS

PARAMETER	SYMBOL	CONDITION	MIN.	TYP.	MAX.	UNIT
Receiver Input to Output from Low to High	t_{RPLH}	$C_L = 15\text{pF}$ Figure 7 & Figure 8		60		ns
Receiver Input to Output from High to Low	t_{RPHL}			60		ns
$ t_{RPLH} - t_{RPHL} $	t_{RPDS}				3	10

PARAMETER	SYMBOL	CONDITION	MIN.	TYP.	MAX.	UNIT
Receiver Enable to Output Low	t_{RPZL}	$C_L=15pF$ Figure7 & Figure8		15	40	ns
Receiver Enable to Output high	t_{RPZH}	$C_L=15pF$ Figure7 & Figure8		15	40	ns
Receiver Disable Time from Low	t_{RPLZ}	$C_L=15pF$ Figure7 & Figure8		25	55	ns
Receiver Disable Time from high	t_{RPZH}	$C_L=15pF$ Figure7 & Figure8		25	55	ns
In Shutdown Mode, Enable to Output High	t_{RPSH}	$C_L=15pF$ Figure7 & Figure8		150	500	ns
In Shutdown Mode, Enable to Output Low	t_{RPSL}	$C_L=15pF$ Figure7 & Figure8		150	500	ns
Time to Shutdown	t_{SHDN}	NOTE2	50		300	ns

NOTE2: If the enable inputs are RE=high and DE=low for less than 50ns, the device is guaranteed not to enter shutdown. If the enable inputs are in this state for at least 300ns, the device is guaranteed to have entered shutdown.

FUNCTION TABLE

Driver Function				
CONTROL		INPUT	OUTPUT	
/RE	DE	DI	A	B
X	1	1	H	L
X	1	0	L	H
0	0	X	Z	Z
1	0	X	Z(shutdown)	
X=irrelevant; Z=high impedance.				

Receiver Function			
CONTROL		INPUT	OUTPUT
/RE	DE	A-B	RO
0	X	$\geq -10mV$	H
0	X	$\leq -200mV$	L
0	X	Open/short circuit	H
1	X	X	Z
X=irrelevant; Z=high impedance.			

TEST CIRCUIT

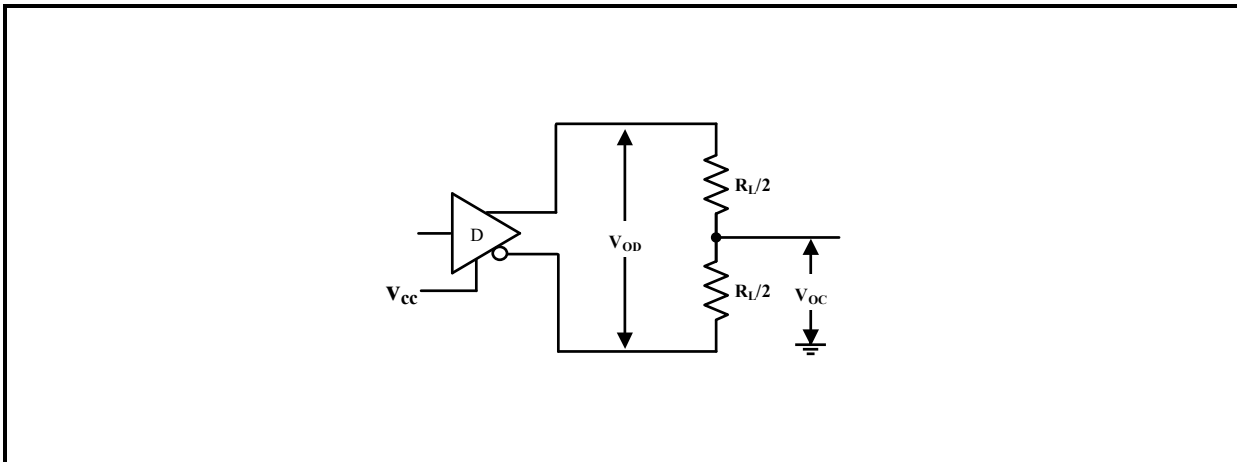
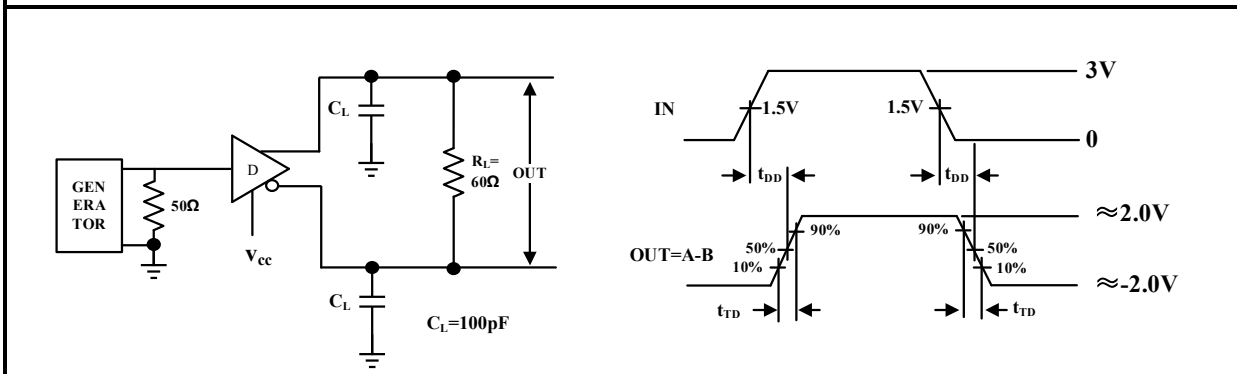
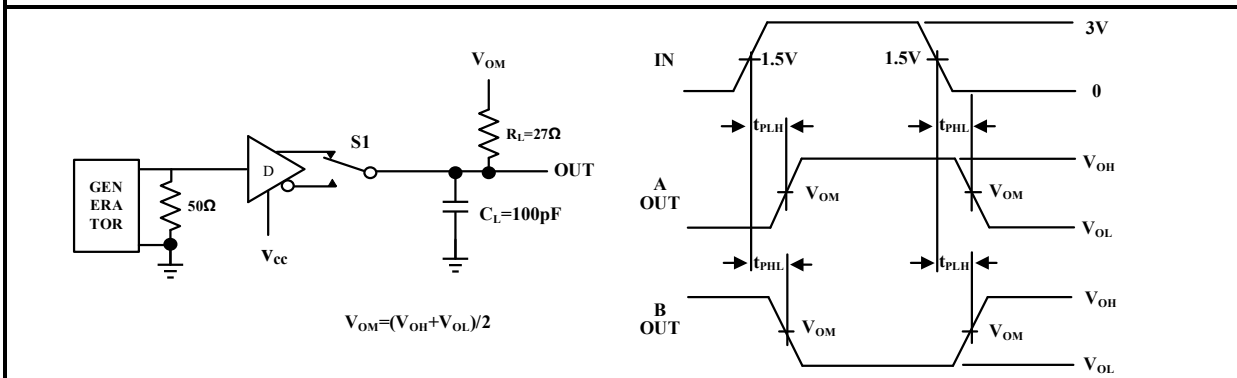

Figure 2 Driver DC test load



CL includes probe and stray capacitance (the same below)

Figure 3 Differential delay and transmit time of driver



$$V_{OM} = (V_{OH} + V_{OL}) / 2$$

Figure 4 Drive propagation delay

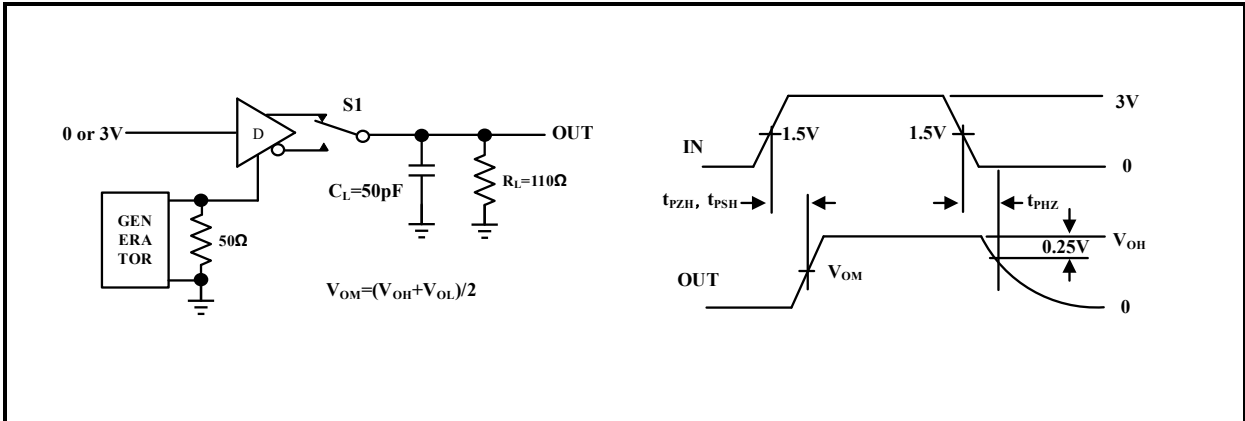

Figure 5 Drive enable and disable time

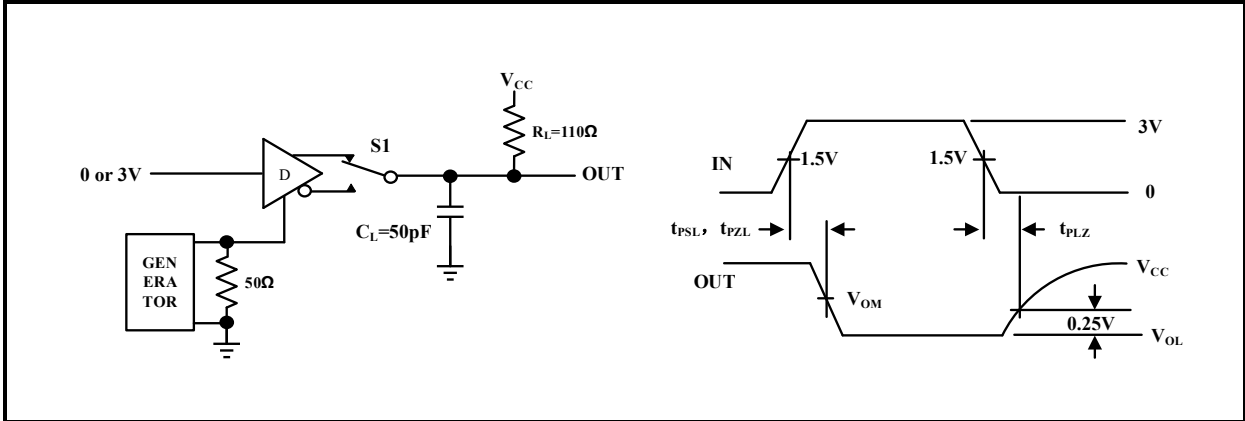

Figure 6 Drive enable and disable time

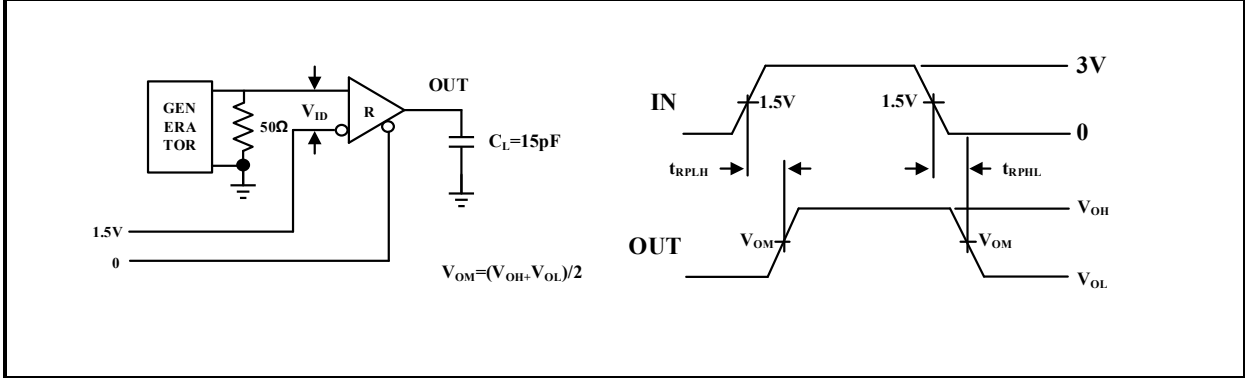
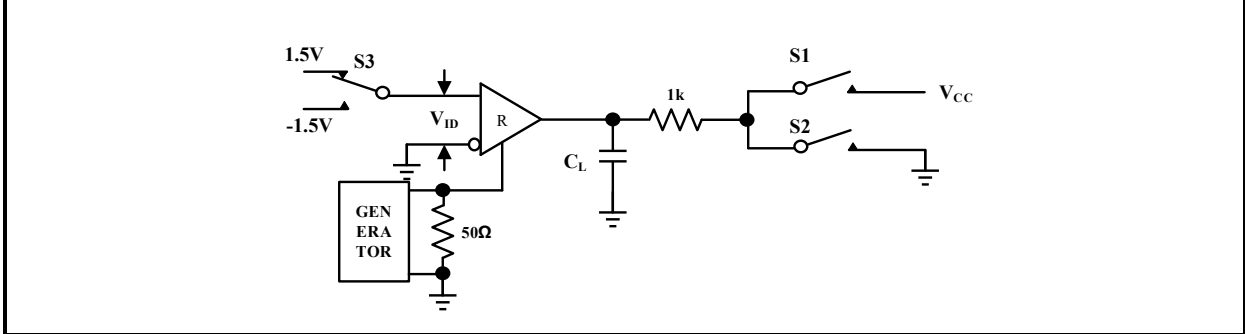
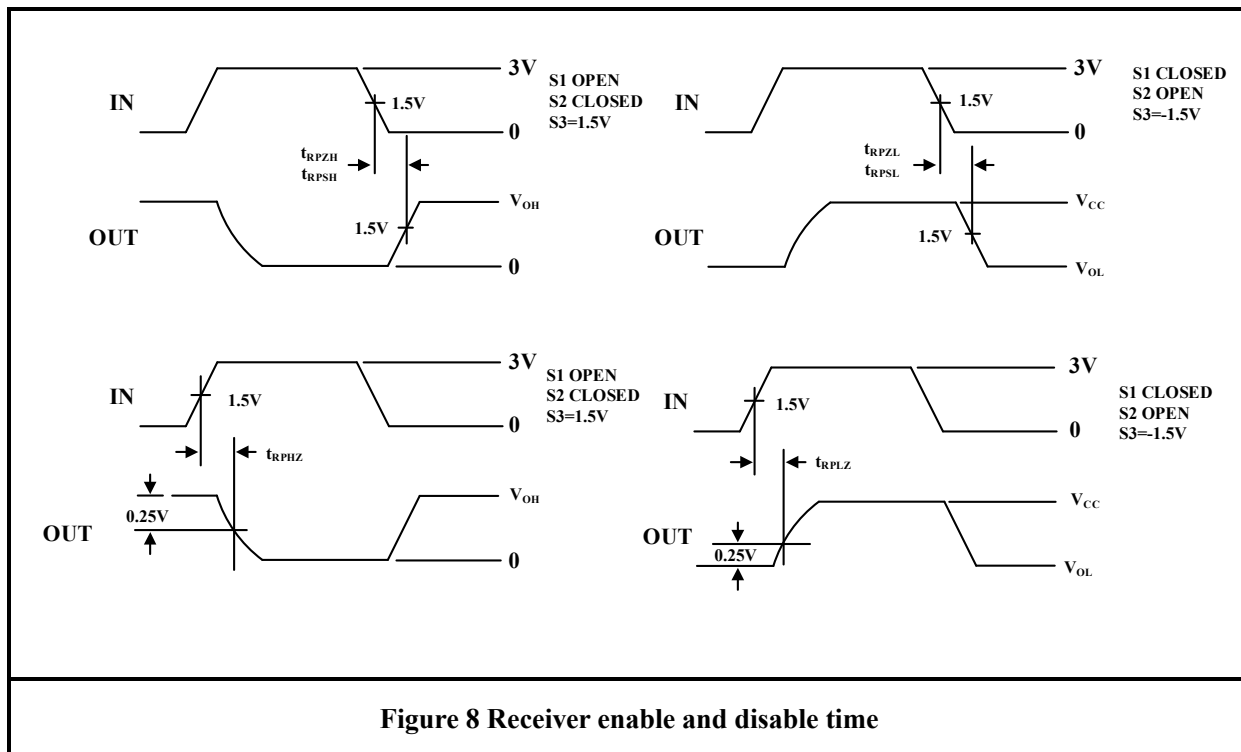

Figure 7 Receiver propagation delay test circuit





ADDITIONAL DESCRIPTION

1 Sketch

SL3088E is a half-duplex high-speed transceiver with 3.0V~5.5V wide power supply, bus port ESD protection capacity of more than 15kV HBM, bus DC withstand voltage of more than $\pm 15V$, used for RS-485/RS-422 communication, including a driver and receiver. It has the functions of fail-safe, over-voltage protection and over-current protection. SL3088E realizes error-free data transmission up to 14Mbps.

2 Allowing up to 256 transceivers on the bus

The input impedance of the standard RS485 receiver is $12k\Omega$ (1 unit load), and the standard driver can drive up to 32 units loads. The receiver of SL3088E transceiver has 1/8 unit load input impedance ($96k\Omega$), which allows up to 256 transceivers to be connected on the same communication bus in parallel. These devices can be combined arbitrarily or with other RS485 transceivers. Any combination of these devices and/or other RS-485 transceivers with a total of 32 unit loads or less can be connected to the line.

3 Driver output protection

Over-current protection features fast short circuit protection in the mode voltage range (refer to typical operating characteristics), which can prevent excessive output current and power dissipation caused by faults or by bus contention.

4 Typical applications

4.1 Bus Networking: SL3088E RS485 transceiver is designed for bidirectional data communication on multi-point bus transmission line. [Figure 9](#) shows a typical network application circuit. These devices can also be used as linear repeaters with cables longer than 4000 feet. In order to reduce reflection, terminal matching should be carried out at both ends of the transmission line with its characteristic impedance, and the length of branch lines outside the main line should be as short as possible.

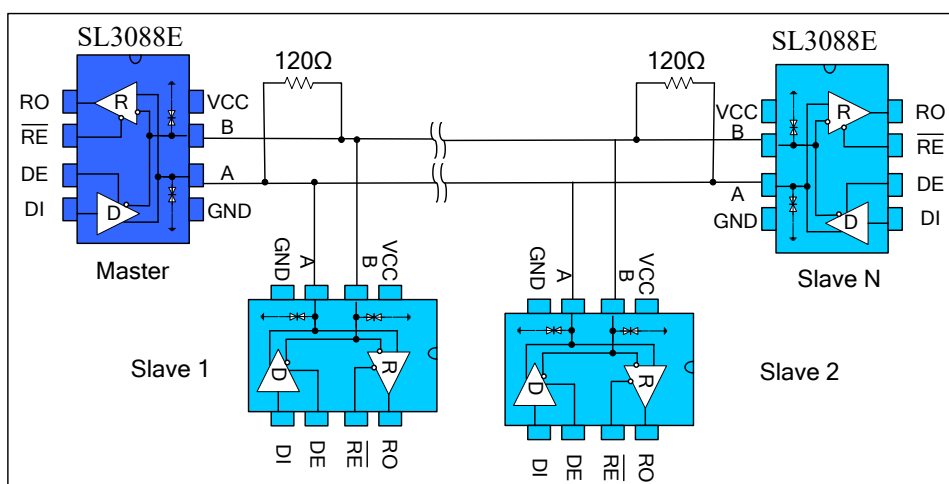

Figure 9 Bus type RS485 half-duplex communication network

4.2 Hand in hand Networking: also known as daisy chain topology, is the standard and specification of RS485 bus wiring, and is the RS485 bus topology recommended by TIA and other organizations. The wiring mode is that the main control equipment and a plurality of slave control equipment form a hand-held connection mode, as shown in [Figure 10](#), and the hand-held mode is no branches. This wiring mode has the advantages of small signal reflection and high communication success rate.

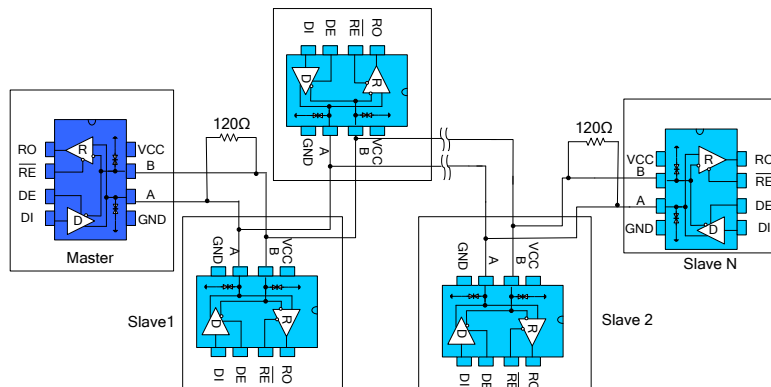

Figure10 Hand in hand RS485 half-duplex communication network

4.3 Bus port protection: in severe environment, RS485 communication port is usually provided with electrostatic protection, lightning surge protection and other additional protection, and even the plan to prevent 380V market electricity access is needed to avoid the damage of intelligent instrument and industrial control host. [Figure 11](#) shows three common RS485 bus port protection schemes. The first is the scheme of three-level protection by connecting TVS devices in parallel with A,B port to the protective ground, TVS devices in parallel with A,B port, thermistor in series with A,B port, gas discharge tube in parallel to the protective ground; the second is the scheme of three-level protection by connecting TVS in parallel with A,B port to the ground, thermistor in series with A,B port, and varistor in parallel with A,B port; the third is the scheme of three-level protection by connecting AB with pull-up or pull-down resistor to power and ground respectively, connecting TVS between A & B, A or B port connecting thermistor.

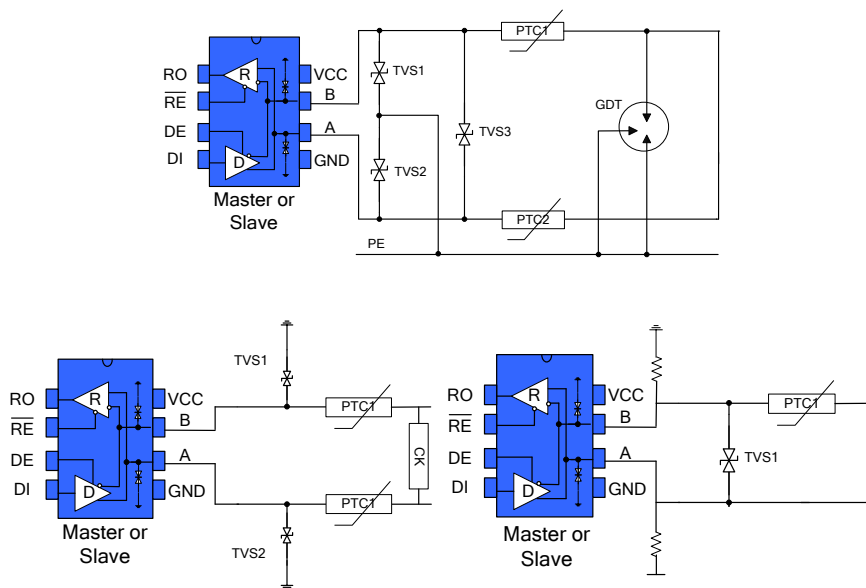
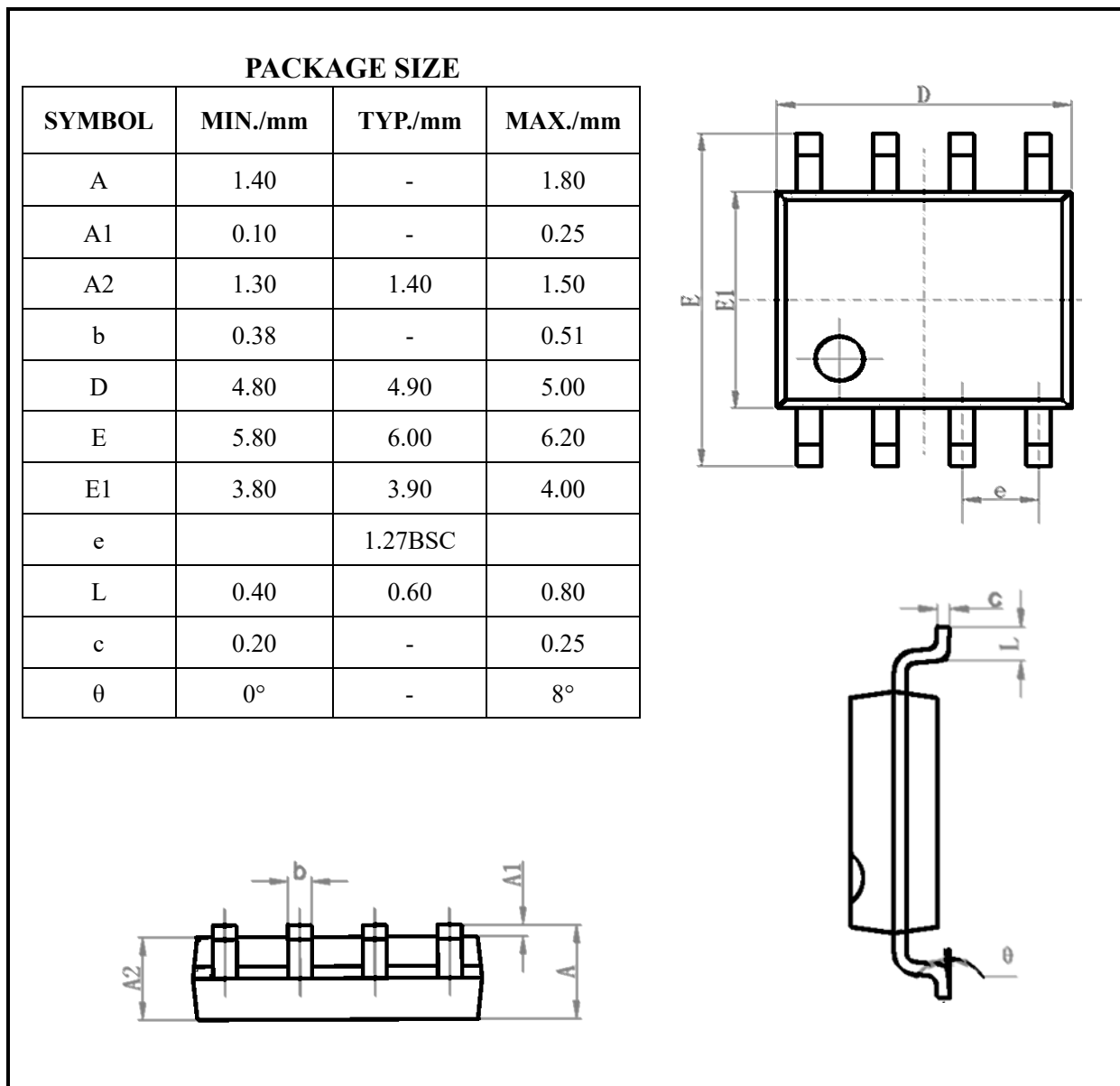
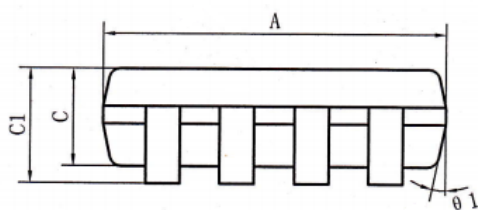
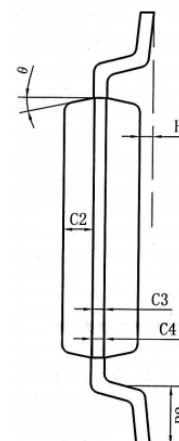
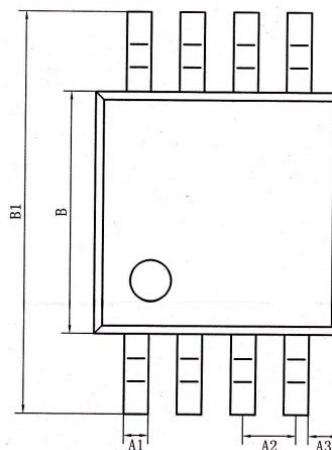

Figure 11 Port protection scheme

SOP8 DIMENSIONS

MSOP8/8 μ MAX/VSSOP8 DIMENSIONS
PACKAGE SIZE

SYMBOL	MIN./mm	TYP./mm	MAX./mm
A	2.90	3.0	3.10
A1	0.28		0.35
A2	0.65TYP		
A3	0.375TYP		
B	2.90	3.0	3.10
B1	4.70		5.10
B2	0.45		0.75
C	0.75		0.95
C1			1.10
C2	0.328 TYP		
C3	0.152		
C4	0.15		0.23
H	0.00		0.09
θ	12°TYP		

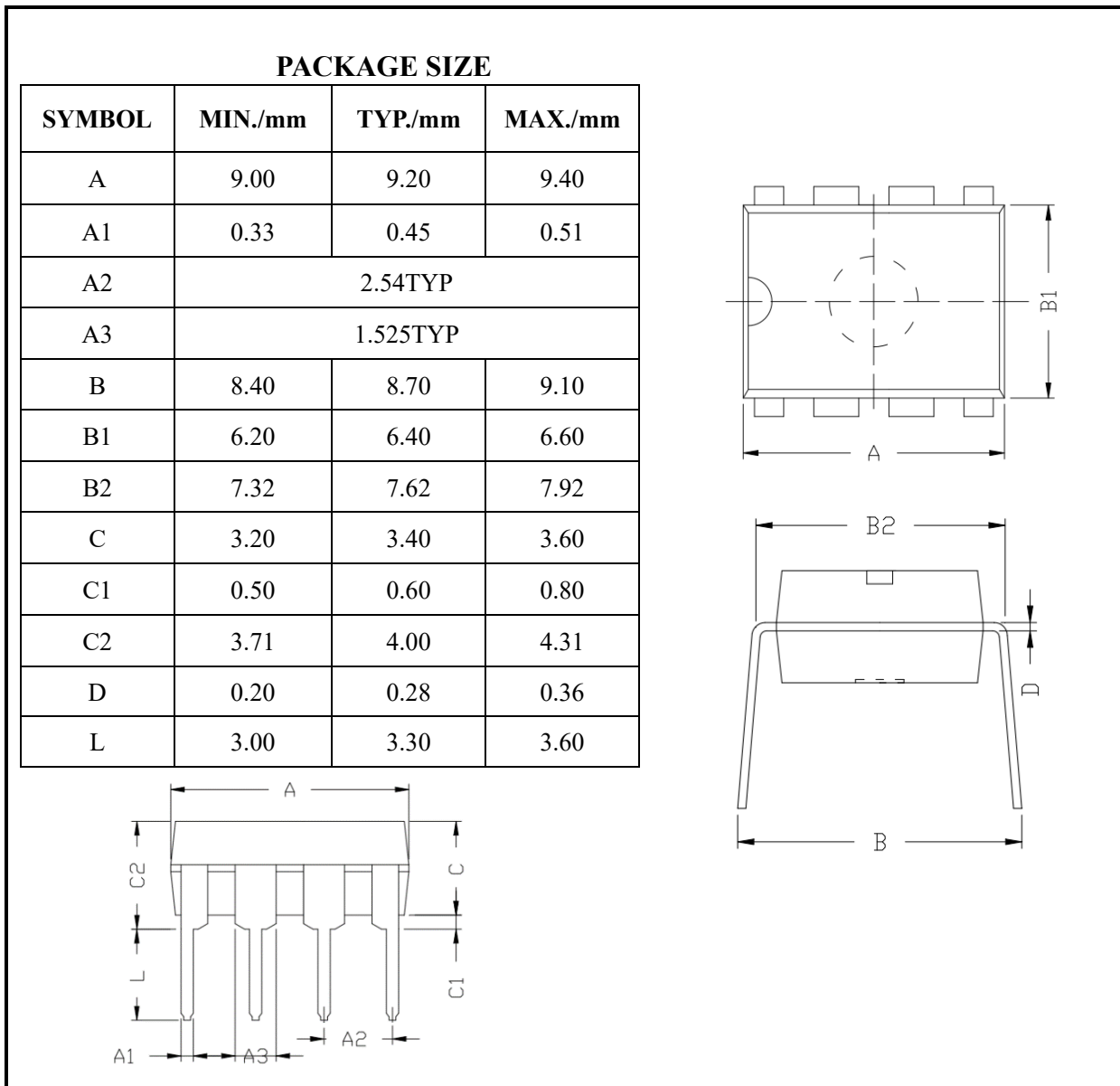

DIP8 DIMENSIONS

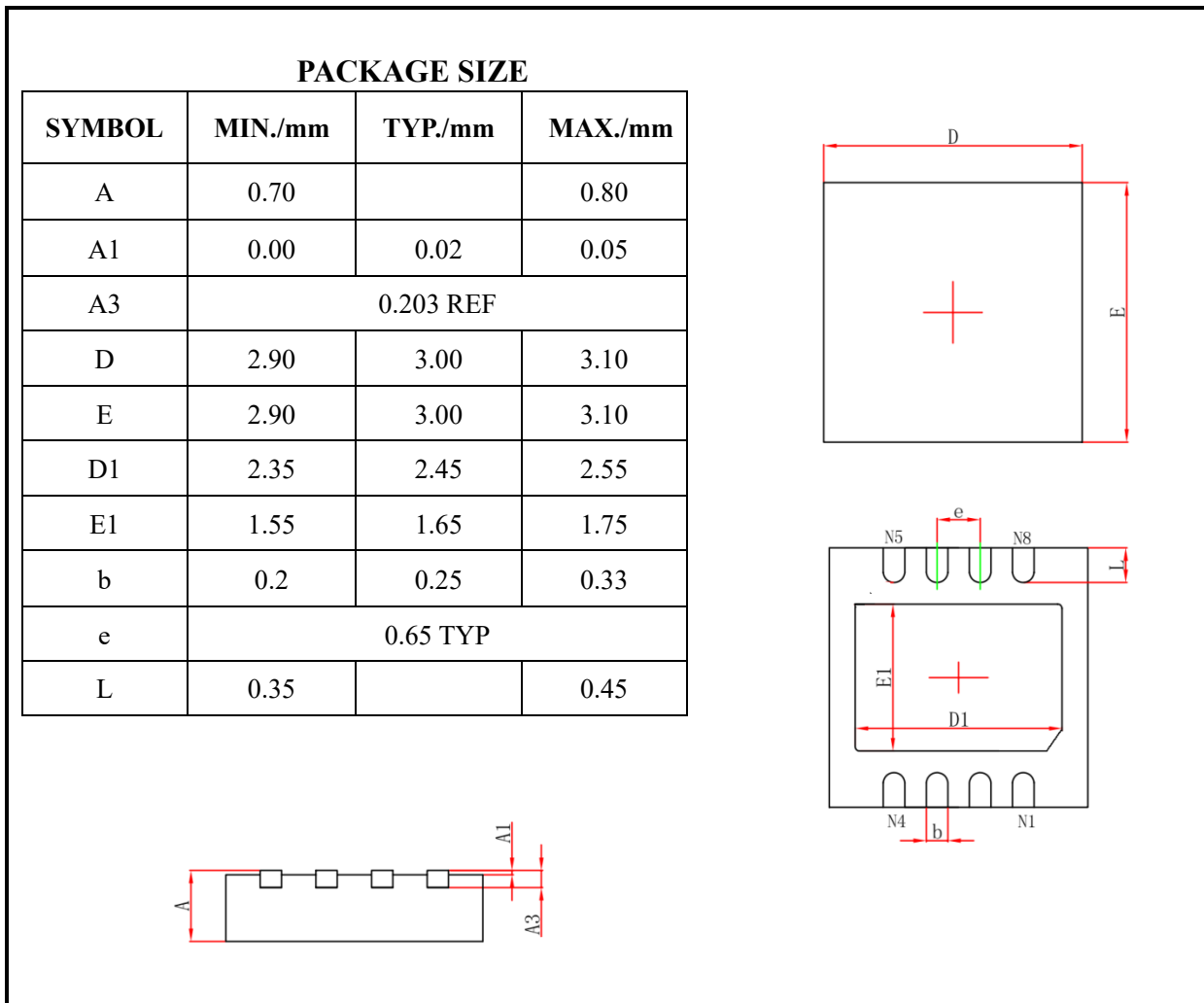
DFN3*3-8 DIMENSIONS

ORDERING INFORMATION

TYPE NUMBER	PACKAGE	PACKING
SL3088EESA	SOP8	Tape and reel
SL3088EEUA	MSOP8/VSSOP8/8 μ MAX	Tape and reel
SL3088EEPA	DIP8	Tube
SL3088ETK	DFN3*3-8	Tape and reel

Tapered package is 2500 pcs/reel. The DFN3*3-8 package is 5000 pcs/reel. DIP8 is packed with 50 pieces/tube in tubed packaging.

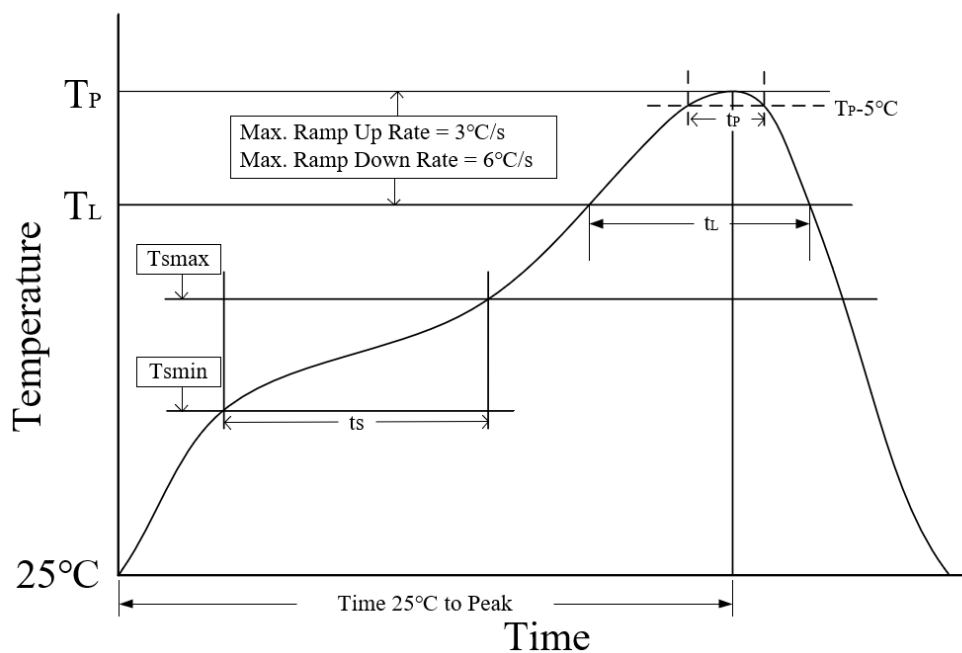
REFLOW SOLDERING

Parameter	Lead-free soldering conditions
Ave ramp up rate (T_L to T_P)	3°C/second max
Preheat time t_s ($T_{smin}=150^\circ C$ to $T_{smax}=200^\circ C$)	60-120 seconds
Melting time t_L ($T_L=217^\circ C$)	60-150 seconds
Peak temp T_P	260-265°C
5°C below peak temperature t_p	30 seconds
Ave cooling rate (T_P to T_L)	6°C/second max
Normal temperature 25°C to peak temperature T_P time	8 minutes max

X-ON Electronics

Largest Supplier of Electrical and Electronic Components

Click to view similar products for [RS-422/RS-485 Interface IC](#) category:

Click to view products by [SLKORMICRO](#) manufacturer:

Other Similar products are found below :

[SP3494CN-L/TR](#) [ISL4486IBZ-T](#) [ISL4491EIB](#) [ISL4491EIBZ-T](#) [ISL81483IB](#) [ISL83086EIB](#) [ISL83088EIB](#) [ISL83488IB](#) [ISL8483EIB](#)
[ISL8487EIB](#) [ISL8489EIB](#) [ISL8491IP](#) [ADM489AN](#) [CA-IF4820HM](#) [CS48505M](#) [CS485S](#) [CS817x22HS](#) [MAX485ESA-MS](#) [MAX3085](#)
[ADM3485EARZ](#) [SP3485EEN](#) [MAX3485ESA](#) [ST3485EBDR](#) [ADM485ARZ](#) [CA-IF4820HD](#) [CA-IF1042S-Q1](#) [CA-IF1021D-Q1](#) [CS48520D](#)
[SN65HVD78EIMM/TR](#) [HGX3085ECMM/TR](#) [SP3085EIMM/TR](#) [HGX3085EIMM/TR](#) [SN65HVD72EIMM/TR](#) [HGX485EIN](#) [RS1905XK](#)
[SIT1044QTK](#) [THVD1420DR](#) [MAX3490EESA+T](#) [UM3483EESA](#) [HD588L](#) [HD568N](#) [HD688ADR](#) [CA-IS3080WX](#) [CA-IS3086WX](#)
[CS817x20HS](#) [CA-IF1044S-Q1](#) [CA-IF4820FS](#) [CA-IF4850HS](#) [GM3490E](#) [WS339E](#)