

InSb Hall Element

Absolute Maximum Ratings

Item	Symbol	Conditions	Limit	Unit
Max. Input Voltage	V_C	$T_a=25^\circ\text{C}$	5	V
Max. Input Power	P_D		25	mW
Operating Temp. Range	T_{opr}		-40~110	$^\circ\text{C}$
Storage Temp. Range	T_{STG}		-40~125	$^\circ\text{C}$

Electrical Characteristics ($T_a=25^\circ\text{C}$)

Item	Symbol	Conditions	Min.	Typ.	Max.	Unit
Output Hall Voltage	V_H^{**}	$B=50\text{mT}, V_C=1\text{V}$	196		370	mV
Input Resistance	R_{in}	$B=0\text{mT}, I_C=0.1\text{mA}$	240		550	Ω
Output Resistance	R_{out}	$B=0\text{mT}, I_C=0.1\text{mA}$	240		550	Ω
Offset Voltage	$V_{OS}(V_u)$	$B=0\text{mT}, V_C=1\text{V}$	-7		+7	mV
Temp. Coefficient of V_H	αV_H^{**}	$B=50\text{mT}, I_C=1\text{mA}$ $T_a=0 \sim 40^\circ\text{C}$		1.8		$\%/^\circ\text{C}$
Temp. Coefficient of R_{in}	αR_{in}^{**}	$B=50\text{mT}, I_C=5\text{mA}$ $T_a=0 \sim 40^\circ\text{C}$		-1.8		$\%/^\circ\text{C}$
Linearity	ΔK^{**}	$B=0.1/0.5\text{T}, I_C=5\text{mA}$			0.5	%

Notes : 1. $V_H = V_{HM} - V_{OS}(V_u)$ (VHM: meter indication)

$$2. \alpha V_H = \frac{1}{V_H(T_1)} \times \frac{V_H(T_2) - V_H(T_1)}{(T_2 - T_1)} \times 100$$

$$3. \alpha R_{in} = \frac{1}{R_{in}(T_1)} \times \frac{R_{in}(T_2) - R_{in}(T_1)}{(T_2 - T_1)} \times 100$$

$$4. \Delta K = \frac{K(B_1) - K(B_2)}{[K(B_1) + K(B_2)] / 2} \times 100$$

$$T_1 = 20^\circ\text{C}, T_2 = 40^\circ\text{C}$$

$$K = \frac{V_H}{I_C \cdot B}$$

$$B_1 = 0.5\text{T}, B_2 = 0.1\text{T}$$

Characteristic Curves

Allowable Package Power Dissipation

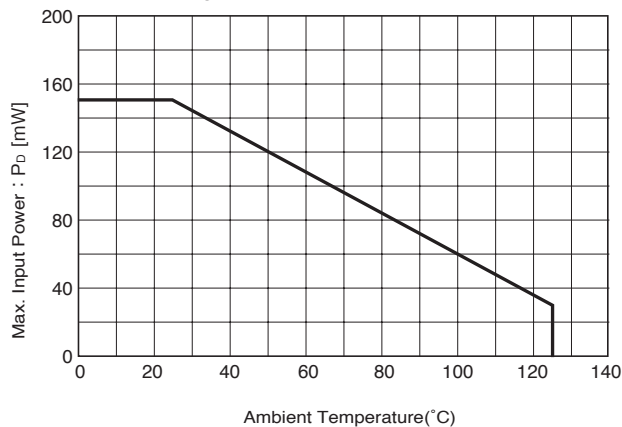

Dimensional Drawing (Unit : mm)

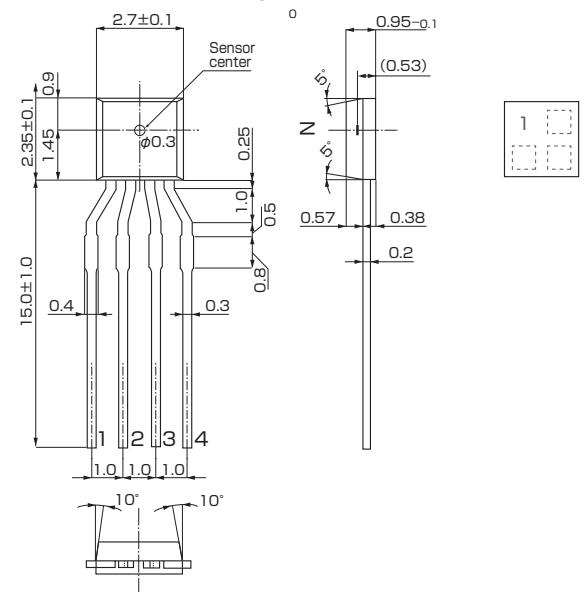

Pinning

1 (+) - 3 (-) (Input)

2 (+) - 4 (-) (Output)

● Characteristic Curves

R_{in}-T

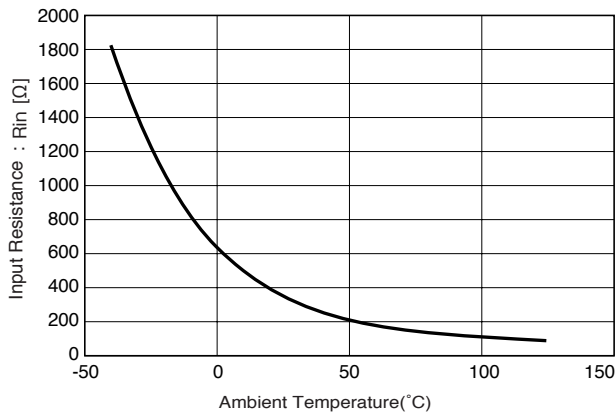

V_H-B

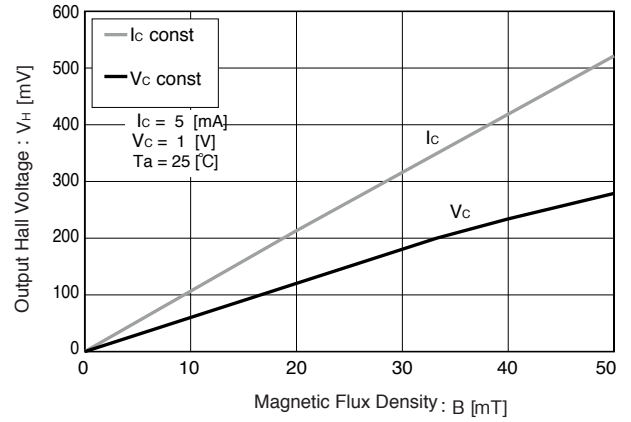

V_H-T

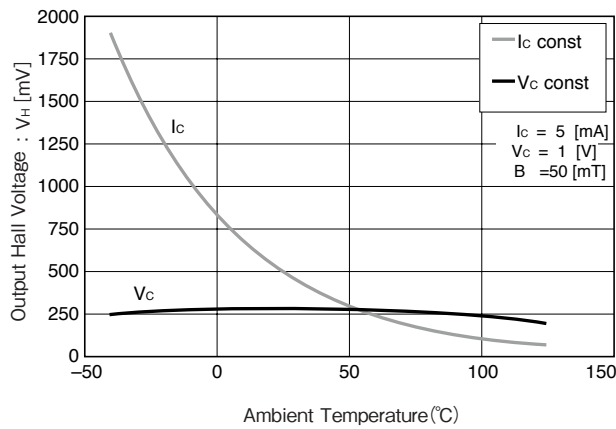

V_H-V_c, V_H-I_c

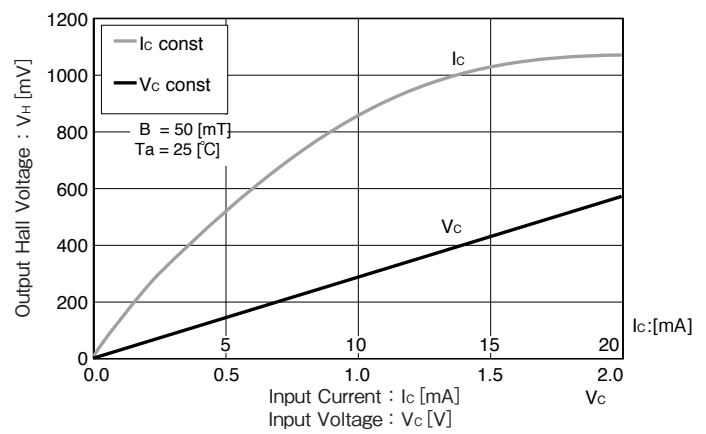

V_{os} (V_u)-T

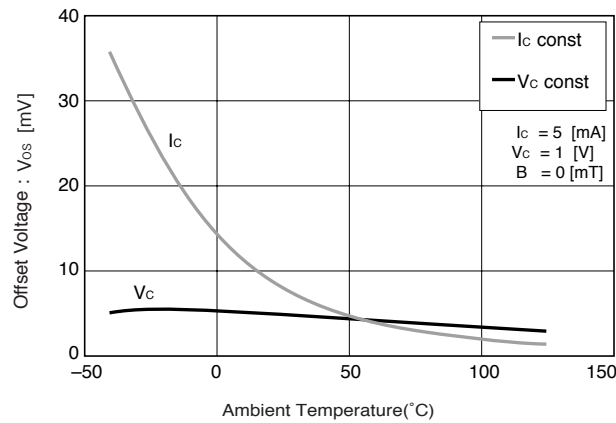

※Magnetic Flux Density
1[mT]=10[G]

V_{os} (V_u)-V_c, V_{os} (V_u)-I_c

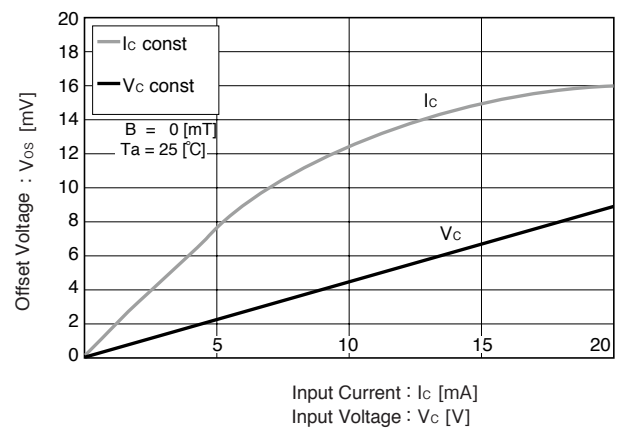

$R_{in} = 750$ [Ω], $V_{os} = 0.6$ [mV] [$V_c = 6$ [V]]
In This Example : $R_{in} = 750$ [Ω], $V_{os} = 0.6$ [mV], [$V_c = 6$ [V]]

X-ON Electronics

Largest Supplier of Electrical and Electronic Components

Click to view similar products for [Board Mount Hall Effect/Magnetic Sensors](#) category:

Click to view products by [SLKORMICRO](#) manufacturer:

Other Similar products are found below :

[HGPRDT005A](#) [AH277AZ4-AG1](#) [AV-10448](#) [HMC1041Z-TR](#) [SS41C](#) [TLE4917](#) [TLE4946-1L](#) [50017859-003](#) [TY-13101](#) [TLE4976L](#)
[SS85CA](#) [BU52002GUL-E2](#) [BU52003GUL-E2](#) [AH277AZ4-BG1](#) [TLE49614MXTSA1](#) [AH3376-P-B](#) [TLE4941](#) [AH211Z4-AG1](#) [AH3360-](#)
[FT4-7](#) [TLE4941-1](#) [AH374-P-A](#) [AH1913-W-7](#) [AH3373-P-B](#) [TLE9852QXXUMA1](#) [MA732GQ-Z](#) [MA330GQ-Z](#) [S-57K1NBL2A-M3T2U](#) [S-](#)
[57P1NBL9S-M3T4U](#) [S-576ZNL2B-L3T2U](#) [S-576ZNL2B-A6T8U](#) [S-57P1NBL0S-M3T4U](#) [S-57A1NSL1A-M3T2U](#) [S-57K1RBL1A-M3T2U](#)
[S-57P1NBH9S-M3T4U](#) [S-57P1NBH0S-M3T4U](#) [S-57A1NSH1A-M3T2U](#) [S-57A1NSH2A-M3T2U](#) [S-57K1NBH1A-M3T2U](#) [S-57A1NNL1A-](#)
[M3T2U](#) [S-5701BC10B-L3T2U5](#) [S-5701BC11B-L3T2U5](#) [S-57GNNL3S-A6T8U](#) [S-57TZ1L1S-A6T8U](#) [S-57GSNL3S-A6T8U](#) [S-](#)
[5716ANDH0-I4T1U](#) [S-57GSNL5S-L3T2U](#) [S-57GDNL3S-L3T2U](#) [S-57GNNL3S-L3T2U](#) [S-57RBNL8S-L3T2U](#) [S-57RBNL9S-A6T8U](#)