

FEATURES

- Supply voltages from 3.0V to 5.5V
- Dual-channel
- 96kbps data rates
- 15kV HBM ESD-Protected
- 8kV IEC-4100-4-2 Contact Discharge

PRODUCT APPEARANCE

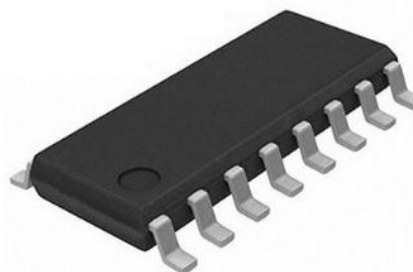

Provide green and environmentally friendly lead-free package

DESCRIPTION

SL3232E is a 3.0V to 5.5V power-supply, dual-channel, high ESD-protected, low-power RS-232 transceiver that fully meets the requirements of the TIA/EIA-232 standard.

SL3232E includes two drives and two receivers, with enhanced ESD protection function, reaching the protection capacity of HBM above 15kV and 8kV IEC-4100-4-2 contact discharge.

When powered, the charge pump only needs four 0.1µF external capacitors to achieve a rate of 96kbps error-free data transmission. Each driver and receiver can be used independently.

PIN CONFIGURATION

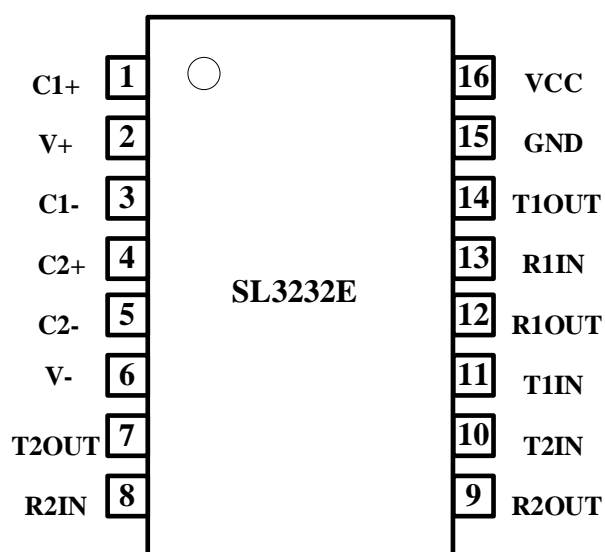

Fig 1 pin configuration

PIN DESCRIPTION

PIN	SYMBOL	DESCRIPTION
1	C1+	Positive Terminal for the first Charge Pump Capacitor
2	V+	Doubled Voltage Terminal
3	C1-	Negative Terminal for the first Charge Pump Capacitor
4	C2+	Positive Terminal for the second Charge Pump Capacitor
5	C2-	Negative Terminal for the second Charge Pump Capacitor
6	V-	Inverted Voltage Terminal
7	T2OUT	Second Transmitter Output Voltage
8	R2IN	Second Receiver Input Voltage
9	R2OUT	Second Receiver Output Voltage
10	T2IN	Second Transmitter Input Voltage
11	T1IN	First Transmitter Input Voltage
12	R1OUT	First Receiver Output Voltage
13	R1IN	First Receiver Input Voltage
14	T1OUT	First Transmitter Output Voltage
15	GND	Ground
16	VCC	Supply Voltage

LIMITING VALUES

PARAMETER	SYMBOL	VALUE	UNIT
Supply voltage	VCC	-0.3~+6	V
Doubled Voltage Terminal	V+	VCC-0.3~+7	V
Inverted Voltage Terminal	V-	+0.3~-7	V
$V+ + V- $		+13	V
Transmitter Input Voltage Range	T1IN, T2IN	-0.3~+6	V
Receiver Input Voltage Range	R1IN, R2IN	±25	V
Transmitter Output Voltage Range	T1OUT, T2OUT	±13.2	V
Receiver Output Voltage Range	R1OUT, R2OUT	-0.3~VCC+0.3	V

PARAMETER	SYMBOL	VALUE	UNIT
Operating Temperature	T_A	-40~85	°C
Storage Temperature	T_{stg}	-60~150	°C
Soldering Temperature		300	°C
Continuous Power	SOP16	760	mW
	DIP16	840	mW

The maximum limit parameters mean that exceeding these values may cause irreversible damage to the device. Under these conditions, it is not conducive to the normal operation of the device. The continuous operation of the device at the maximum allowable rating may affect the reliability of the device. The reference point for all voltages is ground.

SUPPLY CURRENT

PARAMETER	SYMBOL	CONDITION	MIN.	TYP.	MAX.	UNIT
Supply Current with no load	I_{sup}			2		mA

(If there is no additional explanation, typical value is tested when $V_{CC}=+3.3V$, $T_A=25^{\circ}C$, $C1-C4=1\mu F$).

LOGIC INPUT ELECTRICAL CHARACTERISTICS

PARAMETER	SYMBOL	CONDITION	MIN.	TYP.	MAX.	UNIT
Logic Control Low Level	V_{TIN_L}	T1IN, T2IN			0.8	V
Logic Control High Level	V_{TIN_H}	T1IN, T2IN	2			V
Logic Control Hysteresis		T1IN, T2IN		0.3		V
Input Logic Current	I_{TIN}	T1IN, T2IN			± 1	μA

(If there is no additional explanation, typical value is tested when $V_{CC}=+3.3V$, $T_A=25^{\circ}C$, $C1-C4=1\mu F$).

RECEIVER OUTPUT ELECTRICAL CHARACTERISTICS

PARAMETER	SYMBOL	CONDITION	MIN.	TYP.	MAX.	UNIT
Receiver Output Logic-Low Voltage	V_{ROL}	$I_{OUT}=1.6mA$, $V_{CC}=5V$ or $3.3V$			0.4	V
Receiver Output Logic-High Voltage	V_{ROH}	$I_{OUT}=-0.5mA$, $V_{CC}=5V$ or $3.3V$	$V_{CC}-0.6$	$V_{CC}-0.1$		V

(If there is no additional explanation, typical value is tested when $V_{CC}=+3.3V$, $T_A=25^{\circ}C$, $C1-C4=1\mu F$).

RECEIVER INPUT ELECTRICAL CHARACTERISTICS

PARAMETER	SYMBOL	CONDITION	MIN.	TYP.	MAX.	UNIT
Receiver Input Range	V_{RIN}		-25		+25	V
Receiver Input Low Threshold	V_{RIL}	$V_{CC}=3.3V$	0.6	1.1		V
		$V_{CC}=5V$	0.8	1.5		V

PARAMETER	SYMBOL	CONDITION	MIN.	TYP.	MAX.	UNIT
Receiver Input High Threshold	V_{RIH}	VCC=3.3V		1.5	2.4	V
		VCC=5V		1.9	2.4	V
Receiver Input Hysteresis				0.4		V
Receiver Input Impedance	R_{RIN}		3	5	7	k Ω

(If there is no additional explanation, typical value is tested when VCC=+3.3V, T_A=25°C, C1-C4=1 μ F).

TRANSMITTER OUTPUT ELECTRICAL CHARACTERISTICS

PARAMETER	SYMBOL	CONDITION	MIN.	TYP.	MAX.	UNIT
Transmitter Output Swing	V_{TOUT}	All output ports of transmitter connect 3k Ω load to ground	± 4	± 5		V
Transmitter Output Impedance	R_{TOUT}	VCC=0V, Transmitter Input= ± 2 V	300			Ω
Transmitter Short-Circuit Current	I_{TSC}				60	mA

(If there is no additional explanation, typical value is tested when VCC=+3.3V, T_A=25°C, C1-C4=1 μ F).

ESD PROTECTION

PARAMETER	SYMBOL	CONDITION	MIN.	TYP.	MAX.	UNIT
R1IN, R2IN T1OUT, T2OUT		HBM		± 15		kV
		Air Discharge		± 15		kV
		Contact Discharge		± 8		kV

SWITCHING CHARACTERISTICS PARAMETER

PARAMETER	SYMBOL	CONDITION	MIN.	TYP.	MAX.	UNIT
Rate	Speed	R _L =3k Ω , C _L =1000pF		96		kbps

PARAMETER	SYMBOL	CONDITION	MIN.	TYP.	MAX.	UNIT
Receiver Propagation delay	t_{RPHL}	CL=150pF		300		ns
	t_{RPLH}			300		ns
	$ t_{RPHL} - t_{RPLH} $			150		ns
	$ t_{TPHL} - t_{TPLH} $			150		ns
Transmitter Slew Rate	SR	RL=3kΩ~7kΩ, CL=150pF~1000pF from-3.0V~3.0V or from3.0V~-3.0V See Fig 2 and Fig 3	4		30	V/μs

(If there is no additional explanation, typical value is tested when VCC=+3.3V, TA=25°C, C1-C4=1μF).

TEST CIRCUIT

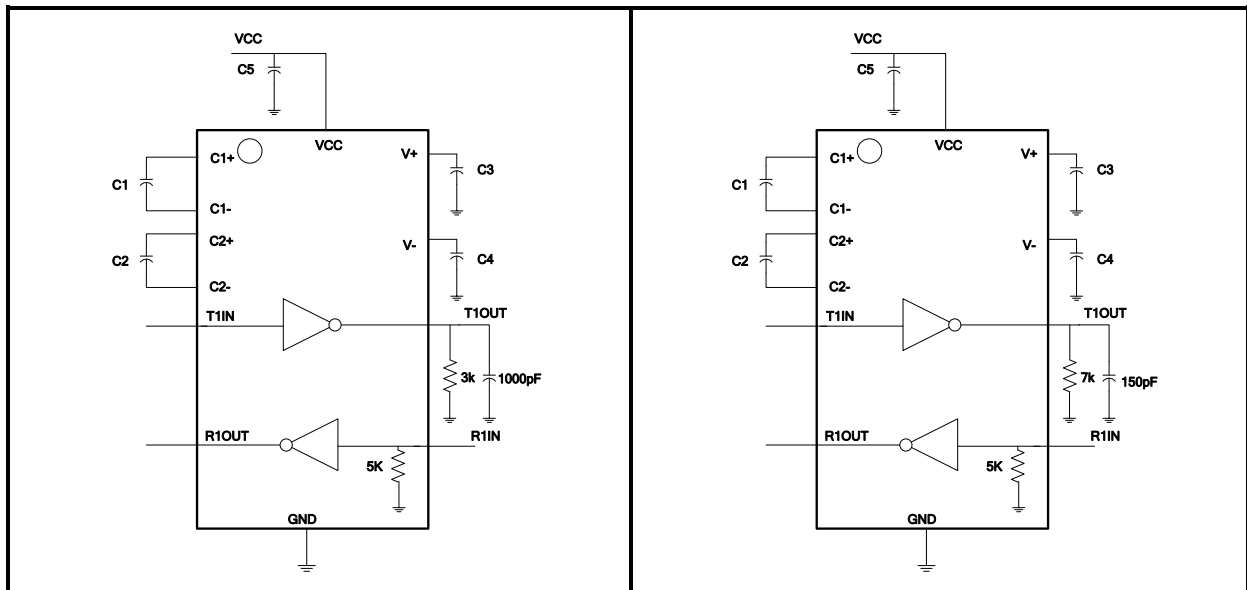

Fig 2 minimum swing rate test circuit

Fig 3 maximum swing rate test circuit

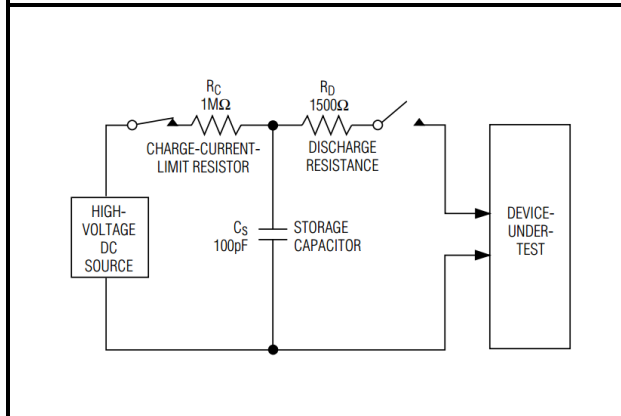

Fig 4 ESD test model of human body mode

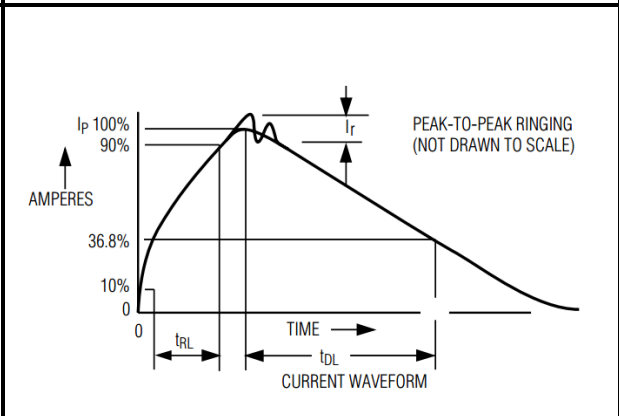

Fig 5 human body mode current waveform

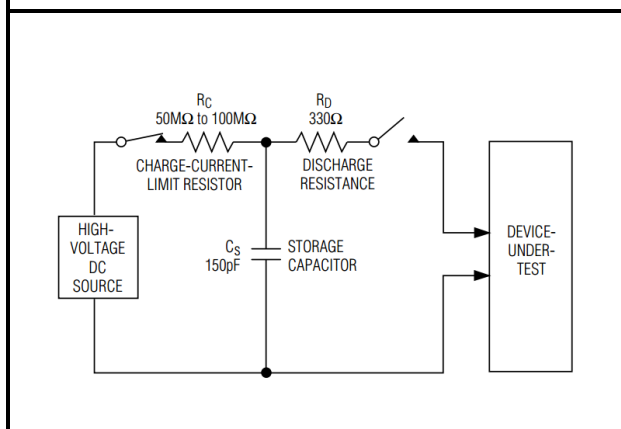

Fig 6 ESD test model of IEC 1000-4-2

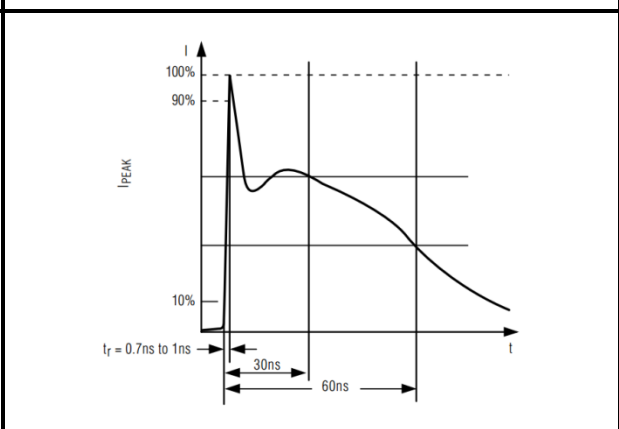

Fig 7 current waveform of IEC 1000-4-2 ESD

ADDITIONAL DESCRIPTION

1 Dual Charge-Pump Operation

SL3232E has a two-way charge pump inside to support the chip's voltage conversion work. Dual-electric pump provides +5.5V and -5.5V output voltage in the range of 3.0 ~ 5.5V, each charge pump requires a capacitor (C1, C2) and an energy storage capacitor (C3, C4) to generate V+ and V-power supplies, as shown in [Fig 8](#).

2 RS232 Transmitter

Convert the TTL/CMOS logic voltage to a voltage compatible with the EIA/TIA-232 standard. SL3232E transmitter can guarantee 96kbps data rate under the worst operating conditions (Parallel load of 3kΩ resistor and 1000pF capacitor). Transmitter can drive multiple receivers in parallel. There is no pull-up resistance inside the input terminals T1IN and T2IN of SL3232E transmitter. If the transmitter is not used, the unused input terminals T1IN and T2IN can be connected to GND or VCC.

3 RS232 Receiver

The SL3232E has two separate receivers that convert the RS-232 signal to the CMOS logic output level.

4 ESD Protection

All pins of SL3232E adopt ESD protection structure, and all driver outputs and receiver inputs have additional electrostatic protection capability. It can withstand ±15kV ESD (HBM) discharge, contact discharge above ±8KV and air gap discharge above ±15kV. The ESD protection structure can withstand the impact of high voltage ESD under all conditions, including standard working mode and power-off mode.

5 Typical Application

Typical dual-Path application scenarios are shown in [Fig 8](#), where the C1-C5 typical capacitance value is 0.1μF.

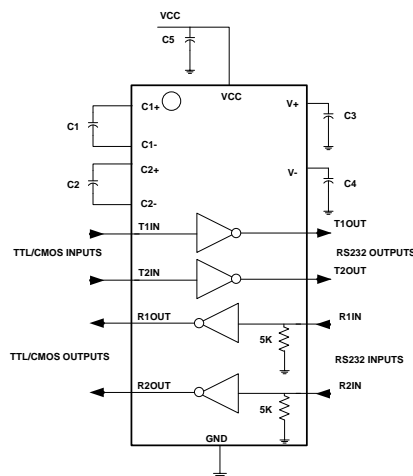
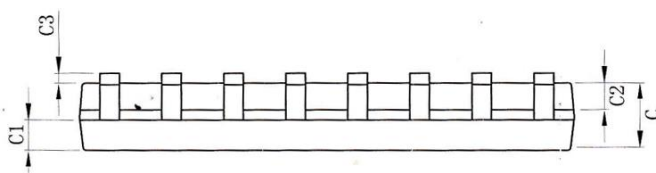
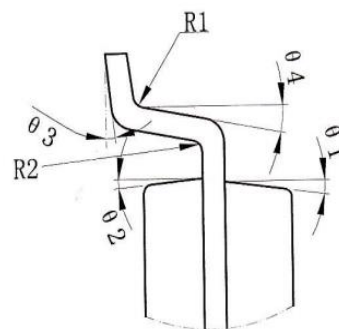
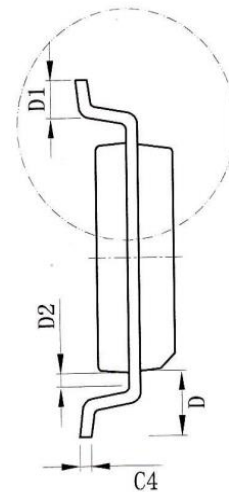
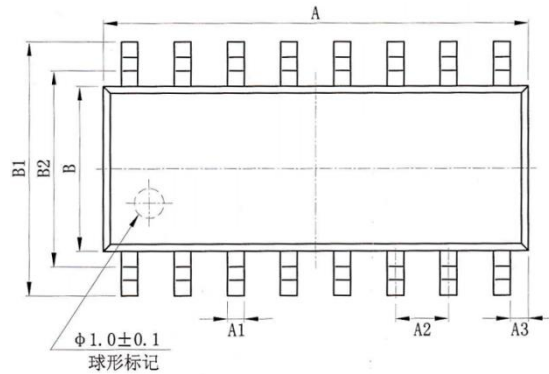

Fig 8 Typical dual-Path application scenarios

SOP16 DIMENSIONS

PACKAGE SIZE

SYMBOL \ SIZE	MIN./mm	MAX./mm
A	9.80	10.00
A1	0.356	0.456
A2	1.27TYP	
A3	0.302TYP	
B	3.85	3.95
B1	5.84	6.24
B2	5.00 TYP	
C	1.40	1.60
C1	0.61	0.71
C2	0.54	0.64
C3	0.05	0.25
C4	0.203	0.233
D	1.05 TYP	
D1	0.40	0.70
D2	0.15	0.25
R1	0.20TYP	
R2	0.20TYP	
θ1	8°~12°TYP4	
θ2	8°~12°TYP4	
θ3	0°~8°	
θ4	4°~12°	



SSOP16(0.65) DIMENSIONS
PACKAGE SIZE

SIZE SYMBOL	MIN/mm	MAX/mm
A	6.15	6.25
A1	0.30TYP	
A2	0.65TYP	
A3	0.675TYP	
B	5.25	5.35
B1	7.65	7.95
B2	0.60	0.80
C	1.70	1.80
C1	1.75	1.95
C2	0.799	
C3	0.152	
C4	0.172	
H	0.05	0.15
θ	12°TYP4	
$\theta 1$	12°TYP4	
$\theta 2$	10°TYP	
$\theta 3$	0°~8°	
R	0.20°TYP	
R	0.15°TYP	

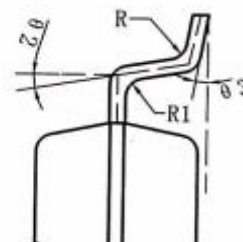
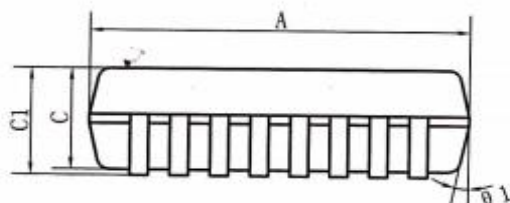
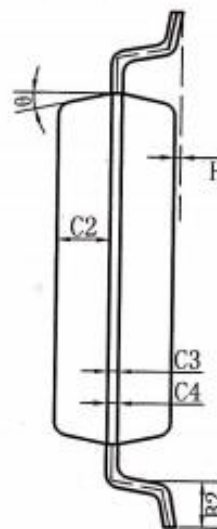
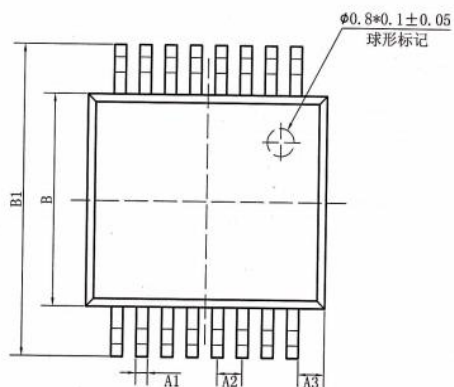

TSSOP16 DIMENSIONS
PACKAGE SIZE

SYMBOL \ SIZE	MIN./mm	TYP./mm	MAX./mm
A	--	--	1.20
A1	0.05		0.15
A2	0.90	1.00	1.05
b	0.20	--	0.30
b1	0.19	0.22	0.25
c	0.110	0.127	0.145
c1	0.12	0.13	0.14
D	4.86	4.96	5.06
E	6.20	6.40	6.60
E1	4.30	4.40	4.50
e	0.65BSC		
L	0.45	0.60	0.75
L1	1.00BSC		
	0°	--	8°

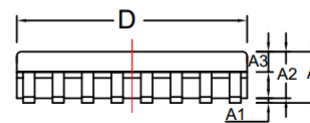
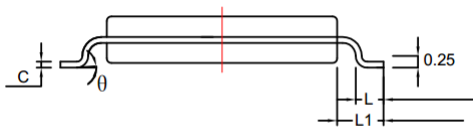
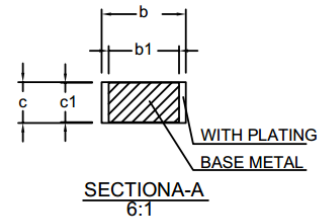
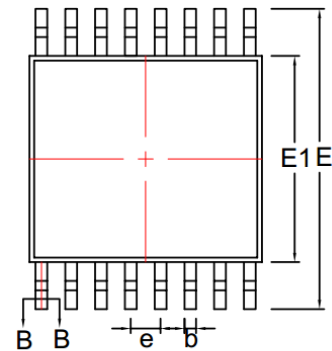

REFLOW SOLDERING

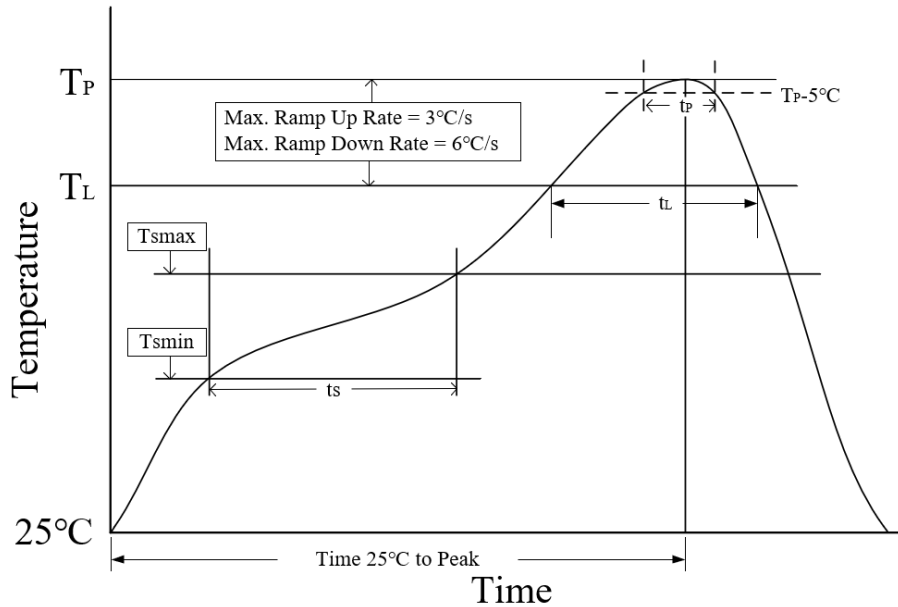

Parameter	Lead-free soldering conditions
Ave ramp up rate (T_L to T_P)	3 °C/second max
Preheat time t_s ($T_{smin}=150$ °C to $T_{smax}=200$ °C)	60-120 seconds
Melting time t_L ($T_L=217$ °C)	60-150 seconds
Peak temp T_P	260-265 °C
5°C below peak temperature t_p	30 seconds
Ave cooling rate (T_P to T_L)	6 °C/second max
Normal temperature 25°C to peak temperature T_P time	8 minutes max

ORDERING INFORMATION

TYPE NUMBER	PACKAGE	PACKING
SL3232EESE	SOP16	Tape and reel
SL3232EEAE	SSOP16	Tape and reel
SL3232EEUE	TSSOP16	Tape and reel
SL3232EEWE	WSOP16 Wide body	Tube

SOP 16, SSOP16 and TSSOP16 is packed with 2500 pieces/disc in braided packing. WSOP16 is packed with 44 pieces/tube in tubed packaging.

X-ON Electronics

Largest Supplier of Electrical and Electronic Components

Click to view similar products for [RS-232 Interface IC category](#):

Click to view products by [SLKORMICRO manufacturer](#):

Other Similar products are found below :

[062191EB](#) [XR32330EBERTR-F](#) [HIN202CB](#) [HIN202CBN](#) [HIN202EIB](#) [HIN206CB](#) [HIN206EIA](#) [HIN207EIAZ](#) [HIN207EIBZ](#) [HIN208ECB](#)
[HIN213EIB](#) [HIN232ACB](#) [HIN232ACBN](#) [HIN232ACP](#) [HIN232CB](#) [HIN232ECP](#) [HIN232IB](#) [HIN232IP](#) [HIN238CB](#) [HIN239CB](#) [HIN241CA](#)
[ICL232CBE](#) [ICL232IBE](#) [ICL3207ECA](#) [ICL3217ECB](#) [ICL3221CV](#) [ICL3221ECA](#) [ICL3221ECV](#) [ICL3221IA](#) [ICL3223CA](#) [ICL3223ECA](#)
[ICL3223IA](#) [ICL3225ECA](#) [ICL3232CA](#) [ICL3232CP](#) [ICL3232CV](#) [ICL3232ECB](#) [ICL3232IBN](#) [ICL3232IV](#) [ICL3237CA](#) [ICL3237ECA](#)
[ICL3238ECA](#) [ICL3241ECA](#) [ICL3243CA](#) [ICL3243CB](#) [ICL3243ECA](#) [ICL3243ECB](#) [ICL3243ECV](#) [ICL3243IA](#) [ICL3245ECA](#)