

N-Channel 60-V(D-S) Power MOSFET

V(BR)DSS	RDS(on)MAX	ID
60 V	20mΩ@ 10 V	50A

General Description:

The high voltage MOSFET uses an advanced termination scheme to provide enhanced voltage-blocking capability without degrading performance over time. In addition, this advanced MOSFET is designed to withstand high energy in avalanche and commutation modes. The new energy efficient design also offers a drain-to-source diode with a fast recovery time. Designed for high voltage, high speed switching applications in power suppliers, converters and PWM motor controls, these devices are particularly well suited for bridge circuits where diode speed and commutating safe operating areas are critical and offer additional and safety margin against unexpected voltage transients.

Equivalent Circuit:

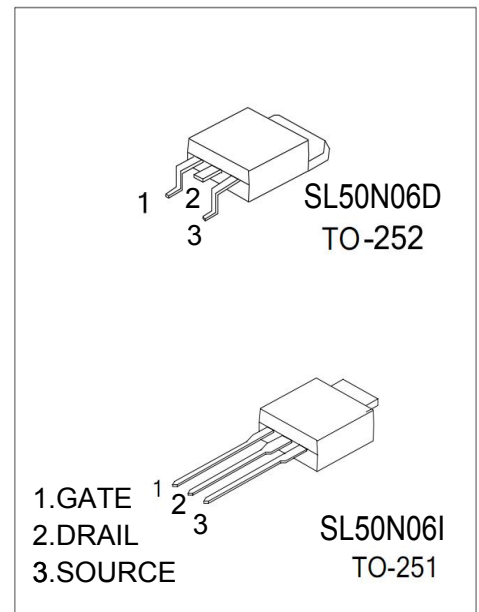

FEATURE:

- ※ Power switching application
- ※ Hard switched and high frequency circuits
- ※ Uninterruptible power supply
- ※ Fully characterized avalanche voltage and current
- ※ Excellent package for good heat dissipation
- ※ Good stability and uniformity with high EAS

SYMBOL:

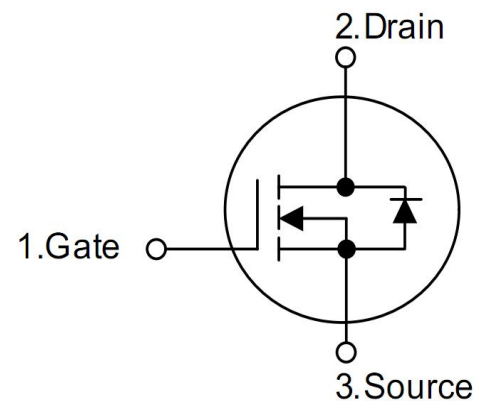

Maximum ratings (Ta=25°C unless otherwise noted)

Parameter	Symbol	Value	Unit
Drain-Source Voltage	VDS	60	V
Gate-Source Voltage	VGS	±20	
Continuous Drain Current	ID	50	A
Pulsed Diode Current	IDM	150	
Power Dissipation	PD	136	W
Thermal Resistance from Junction to Ambient (t≤10s)	RθJA	100	°C/W
Operating Junction	TJ	150	°C
Storage Temperature	TSTG	-55~+150	

MOSFET ELECTRICAL CHARACTERISTICS
Static Electrical Characteristics (Ta = 25 °C Unless Otherwise Noted)

Parameter	Symbol	Test Condition	Min	Typ	Max	Unit
Static						
Drain-source breakdown voltage	V(BR)DSS	VGS = 0V, ID = 250μA	60			V
Gate-source threshold voltage	VGS(th)	VDS = VGS, ID = 250μA	1.2		2.5	V
Gate-source leakage	IGSS	VDS = 0V, VGS = ±20V			±100	nA
Zero gate voltage drain current	IDSS	VDS = 60V, VGS = 0V			1	μA
Drain-source on-state resistance ^a	RDS(on)	VGS = 10V, ID = 30A		14.5	20	mΩ
Forward transconductance ^a	gfs	VDS = 25V, ID = 25A	24			S
Diode forward voltage	VSD	IS = 10A, VGS = 0V		0.8	1.3	V
Dynamic						
Input capacitance	Ciss	VDS = 25V, VGS = 0V, f = 1MHz		900		pF
Output capacitance	Coss			104		pF
Reverse transfer capacitance ^b	Crss			33		pF
Total gate charge	Qg	VDS = 25V, VGS = 10V, ID = 50A		30		nC
Gate-source charge	Qgs			10		nC
Gate-drain charge	Qgd			5		nC
Switching^b						
Turn-on delay time	td(on)	VDD = 30V RL = 25Ω, ID = 25A, VGEN = 10V, Rg = 25Ω		25		ns
Rise time	tr			5		ns
Turn-off delay time	td(off)			50		ns
Fall time	tf			6		ns
Drain-Source Diode Characteristics						
Continuous Source-Drain Diode Current	IS				50	A
Pulsed Diode forward Current	ISM				220	A

Note :

1. Repetitive Rating : Pulse width limited by maximum junction temperature.
2. Surface Mounted on FR4 Board, t < 10 sec.
3. Pulse Test : Pulse Width ≤ 300μs, Duty Cycle ≤ 2%.
4. Guaranteed by design, not subject to production testing.

PACKAGE OUTLINE DIMENSIONS :

TO-252

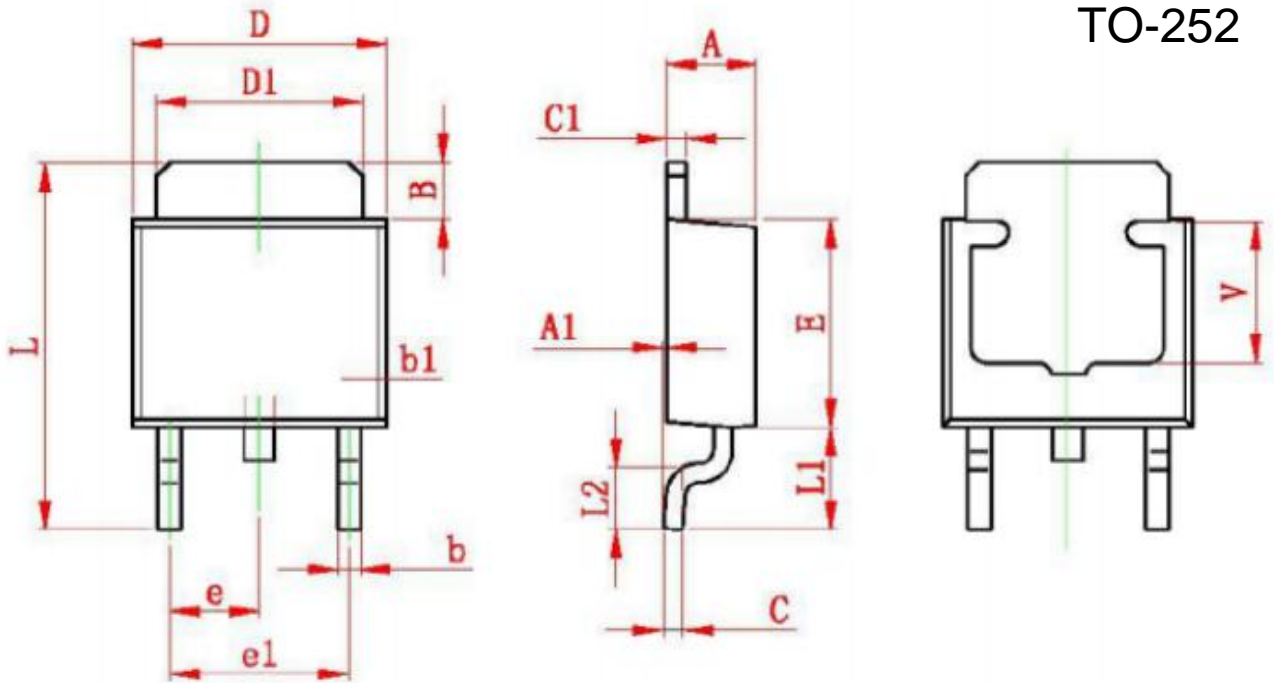

Symbol	Dimensions In Millimeters		Dimensions In Inches	
	Min	Max	Min	Max
A	2.200	2.400	0.087	0.094
A1	0.000	0.127	0.000	0.005
B	1.350	1.650	0.053	0.065
b	0.500	0.700	0.020	0.028
b1	0.700	0.900	0.028	0.035
c	0.430	0.580	0.017	0.023
c1	0.430	0.580	0.017	0.023
D	6.350	6.650	0.250	0.262
D1	5.200	5.400	0.205	0.213
E	5.400	5.700	0.213	0.224
e	2.300 TYP		0.091 TYP	
e1	4.500	4.700	0.177	0.185
L	9.500	9.900	0.374	0.390
L1	2.550	2.900	0.100	0.114
L2	1.400	1.780	0.055	0.070
V	3.80 REF		0.150 REF	

PACKAGE OUTLINE DIMENSIONS :

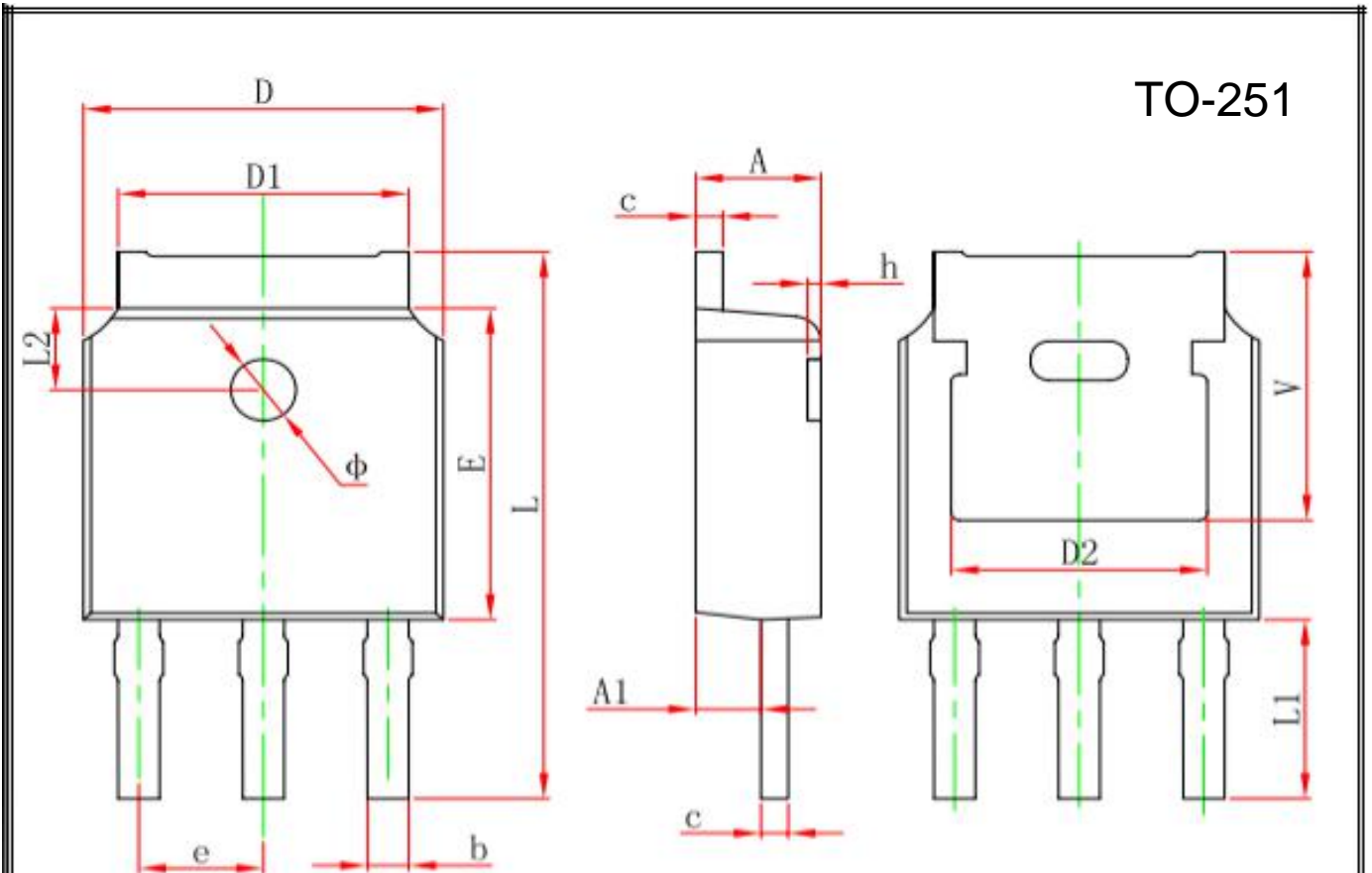

TO-251

Symbol	Dimensions In Millimeters		Dimensions In Inches	
	Min.	Max.	Min.	Max.
A	2.200	2.400	0.087	0.094
A1	0.860	1.160	0.034	0.046
b	0.660	0.860	0.026	0.034
c	0.460	0.580	0.018	0.023
D	6.500	6.700	0.256	0.264
D1	5.100	5.460	0.201	0.215
D2	4.830 REF.		0.190 REF.	
E	6.000	6.200	0.236	0.244
e	2.186	2.386	0.086	0.094
L	10.400	11.000	0.409	0.433
L1	3.300	3.700	0.130	0.146
L2	1.600 REF.		0.063 REF.	
Φ	1.100	1.300	0.043	0.051
h	0.000	0.300	0.000	0.012
V	5.350 REF.		0.211 REF.	

X-ON Electronics

Largest Supplier of Electrical and Electronic Components

Click to view similar products for [MOSFET](#) category:

Click to view products by [SLKORMICRO](#) manufacturer:

Other Similar products are found below :

[IRFD120](#) [JANTX2N5237](#) [2SK2267\(Q\)](#) [BUK455-60A/B](#) [TK100A10N1,S4X\(S](#) [MIC4420CM-TR](#) [VN1206L](#) [NDP4060](#) [SI4482DY](#)
[IRS2092STRPBF-EL](#) [IPS70R2K0CEAKMA1](#) [TK31J60W5,S1VQ\(O](#) [TK31J60W,S1VQ\(O](#) [TK16J60W,S1VQ\(O](#) [2SK2614\(TE16L1,Q\)](#)
[DMN1017UCP3-7](#) [EFC2J004NUZTDG](#) [P85W28HP2F-7071](#) [DMN1053UCP4-7](#) [NTE2384](#) [DMC2700UDMQ-7](#) [DMN2080UCB4-7](#)
[DMN61D9UWQ-13](#) [US6M2GTR](#) [DMN31D5UDJ-7](#) [DMP22D4UFO-7B](#) [IPS60R3K4CEAKMA1](#) [DMN1006UCA6-7](#) [DMN16M9UCA6-7](#)
[STF5N65M6](#) [IRF40H233XTMA1](#) [STU5N65M6](#) [DMN6022SSD-13](#) [DMN13M9UCA6-7](#) [DMTH10H4M6SPS-13](#) [IPS60R360PFD7SAKMA1](#)
[DMN2990UFB-7B](#) [SSM3K35CT,L3F](#) [IPLK60R1K0PFD7ATMA1](#) [2N7002W-G](#) [MCAC30N06Y-TP](#) [IPWS65R035CFD7AXKSA1](#)
[MCQ7328-TP](#) [SSM3J143TU,LXHF](#) [DMN12M3UCA6-7](#) [PJMF280N65E1_T0_00201](#) [PJMF380N65E1_T0_00201](#)
[PJMF280N60E1_T0_00201](#) [PJMF600N65E1_T0_00201](#) [PJMF900N65E1_T0_00201](#)