

## P-Channel 60V (D-S) MOSFET

### Description:

This P-Channel MOSFET uses advanced trench technology and design to provide excellent  $R_{DS(on)}$  with low gate charge.

It can be used in a wide variety of applications.

### Features:

- 1)  $V_{DS}=-60V, I_D=-50A, R_{DS(ON)}<20m\ \Omega @V_{GS}=-10V$
- 2) Low gate charge.
- 3) Green device available.
- 4) Advanced high cell density trench technology for ultra low  $R_{DS(ON)}$ .
- 5) Excellent package for good heat dissipation.

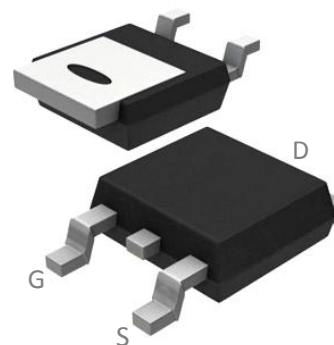

TO-252

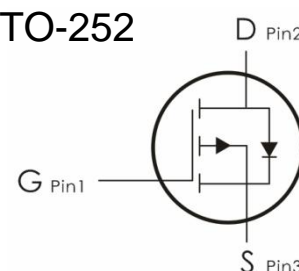

### Absolute Maximum Ratings: ( $T_C=25^\circ C$ unless otherwise noted)

Symbol	Parameter	Ratings	Units
$V_{DS}$	Drain-Source Voltage	-60	V
$V_{GS}$	Gate-Source Voltage	$\pm 20$	V
$I_D$	Continuous Drain Current- $T_C=25^\circ C$	-50	A
	Continuous Drain Current- $T_C=100^\circ C$	-40	A
$I_{DM}$	Pulsed Drain Current <sup>1</sup>	-280	A
$P_D$	Total Power Dissipation	270	W
$E_{AS}$	Single Pulsed Avalanche Energy	700	mJ
$T_J, T_{STG}$	Operating and Storage Junction Temperature Range	-55 to +150	$^\circ C$

### Thermal Characteristics:

Symbol	Parameter	Max	Units
$R_{\theta JC}$	Thermal Resistance, Junction to Case	0.46	$^\circ C/W$

**Electrical Characteristics:** ( $T_C=25^\circ\text{C}$  unless otherwise noted)

Symbol	Parameter	Conditions	Min	Typ	Max	Units
<b>Off Characteristics</b>						
<b>BV<sub>DSS</sub></b>	Drain-Source Breakdown Voltage	$V_{GS}=0V, I_D=-250\ \mu\text{A}$	-60	---	---	V
<b>I<sub>DSS</sub></b>	Zero Gate Voltage Drain Current	$V_{GS}=0V, V_{DS}=-60V$	---	---	-1	$\mu\text{A}$
<b>I<sub>GSS</sub></b>	Gate-Source Leakage Current	$V_{GS}=\pm 20V, V_{DS}=0A$	---	---	$\pm 100$	nA
<b>On Characteristics</b>						
<b>V<sub>GS(th)</sub></b>	GATE-Source Threshold Voltage	$V_{GS}=V_{DS}, I_D=-250\ \mu\text{A}$	-1.1	-1.6	-2.2	V
<b>R<sub>DS(on)</sub></b>	Static Drain-Source On-Resistance	$V_{GS}=-10V, I_D=-20A$	---	16.5	20	m $\Omega$
		$V_{GS}=-4.5V, I_D=-20A$	---	18.5	22	
<b>Dynamic Characteristics</b>						
<b>C<sub>iss</sub></b>	Input Capacitance	$V_{DS}=-20V, V_{GS}=0V, f=1\text{MHz}$	---	4399	---	pF
<b>C<sub>oss</sub></b>	Output Capacitance		---	258	---	
<b>C<sub>rss</sub></b>	Reverse Transfer Capacitance		---	211	---	
<b>Switching Characteristics</b>						
<b>t<sub>d(on)</sub></b>	Turn-On Delay Time	$V_{DD}=-30V, I_D=-20A,$ $V_{GS}=-10V, R_G=1\ \Omega$	---	23	---	ns
<b>t<sub>r</sub></b>	Rise Time		---	17	---	ns
<b>t<sub>d(off)</sub></b>	Turn-Off Delay Time		---	55	---	ns
<b>t<sub>f</sub></b>	Fall Time		---	29	---	ns
<b>Q<sub>g</sub></b>	Total Gate Charge	$V_{GS}=-10V, V_{DS}=-30V,$ $I_D=-20A$	---	114	---	nC
<b>Q<sub>gs</sub></b>	Gate-Source Charge		---	27.3	---	nC
<b>Q<sub>gd</sub></b>	Gate-Drain "Miller" Charge		---	49	---	nC
<b>Drain-Source Diode Characteristics</b>						
<b>V<sub>SD</sub></b>	Drain Diode Forward Voltage	$V_{GS}=0V, I_S=-20A$	---	---	-1.2	V

<b>I<sub>S</sub></b>	Continuous Source Current	V <sub>G</sub> =V <sub>D</sub> =0V	---	---	-50	A
<b>I<sub>SM</sub></b>	Pulsed Source Current		---	---	-280	A
<b>T<sub>rr</sub></b>	Reverse Recovery Time	T <sub>J</sub> = 25° C, I <sub>F</sub> = -20A,	---	117	---	nS
<b>Q<sub>rr</sub></b>	Reverse Recovery Charge	di/dt = 100A/μs	---	420	---	nC

### Notes:

1. Repetitive Rating: Pulse Width Limited by Maximum Junction Temperature
2. EAS condition: T<sub>J</sub> = 25°C, V<sub>DD</sub> = -25V, V<sub>G</sub> = -5V, R<sub>G</sub> = 25Ω, L = 0.5mH, I<sub>AS</sub>
3. Pulse Test: Pulse Width ≤ 300μs, Duty Cycle ≤ 0.5%

### Typical Characteristics: (T<sub>C</sub> = 25°C unless otherwise noted)

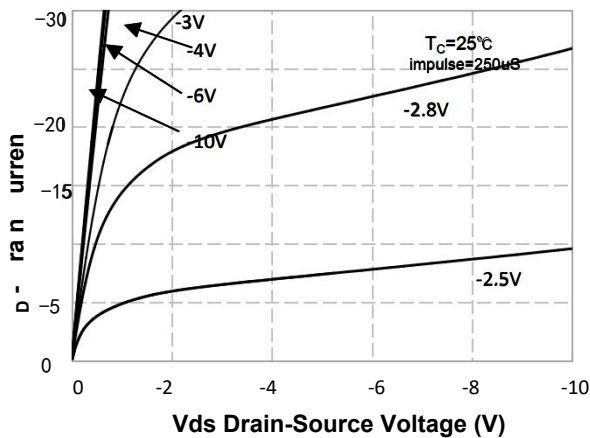

Figure 1. On-Region Characteristics

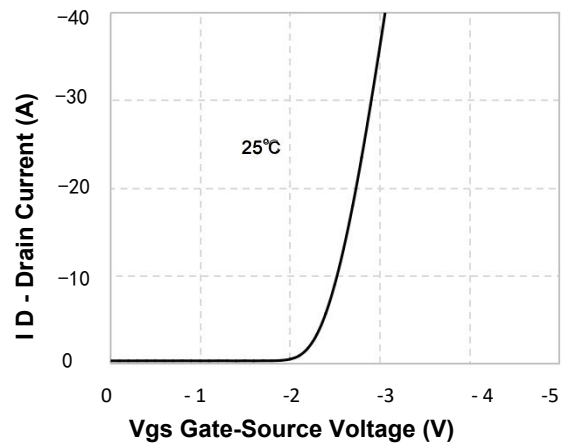

Figure 2. Transfer Characteristics

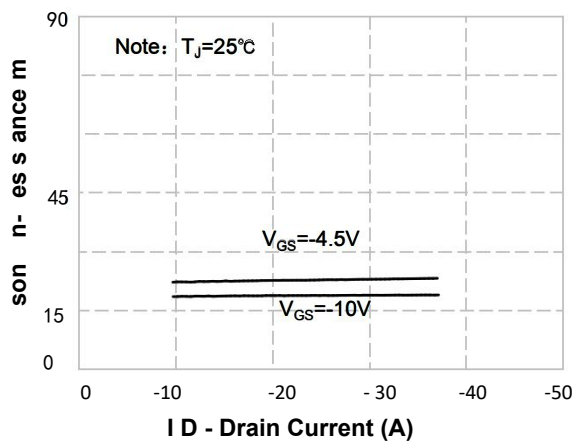

Figure 3. On-Resistance Variation vs Drain Current and Gate Voltage

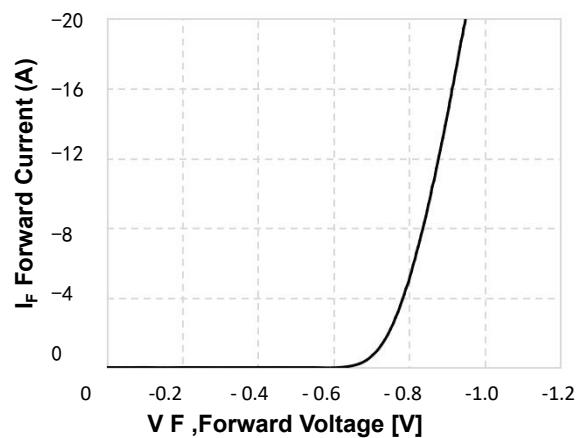

Figure 4. Body Diode Forward Voltage Variation with Source Current and Temperature

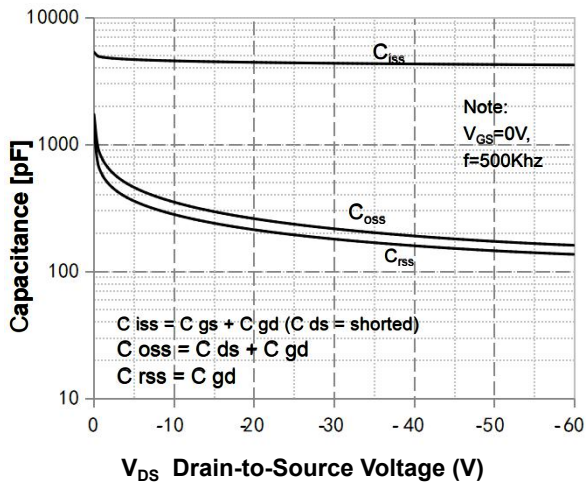

Figure 5. Capacitance Characteristics

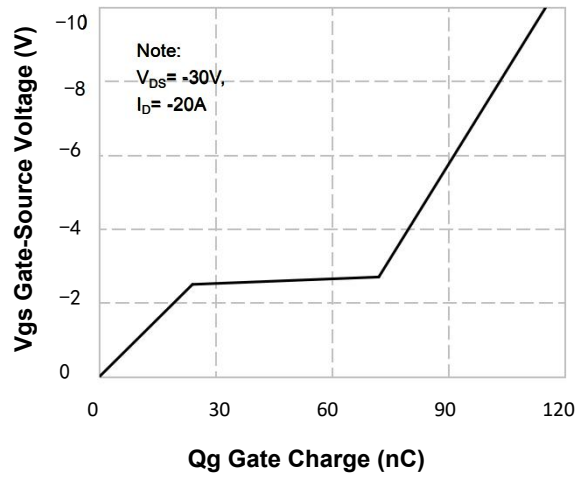

Figure 6. Gate Charge Characteristics

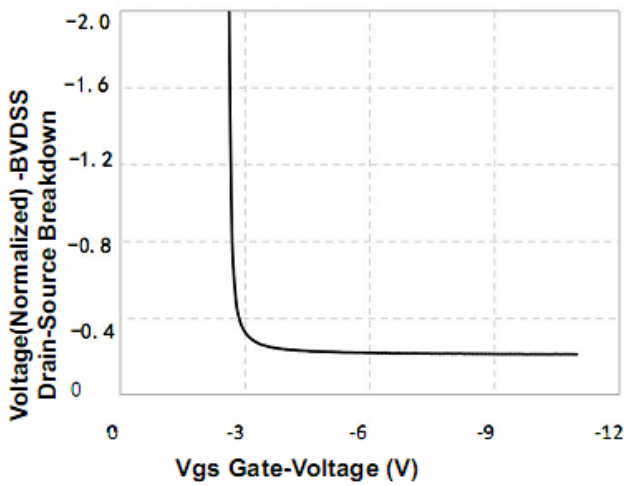

Figure 7. Breakdown Voltage Variation vs Gate-Voltage

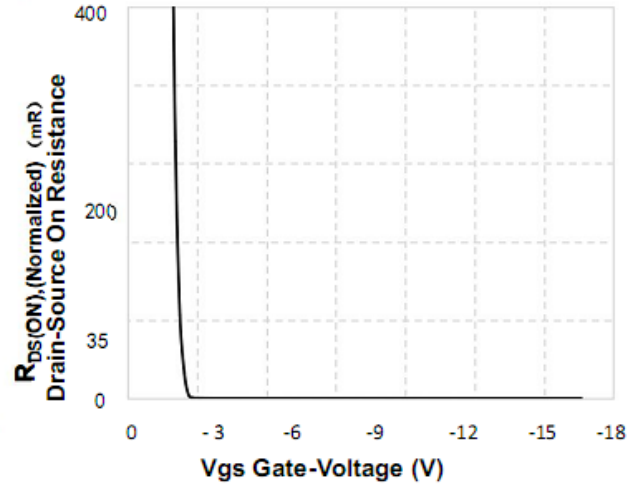

Figure 8. On-Resistance Variation vs Gate Voltage

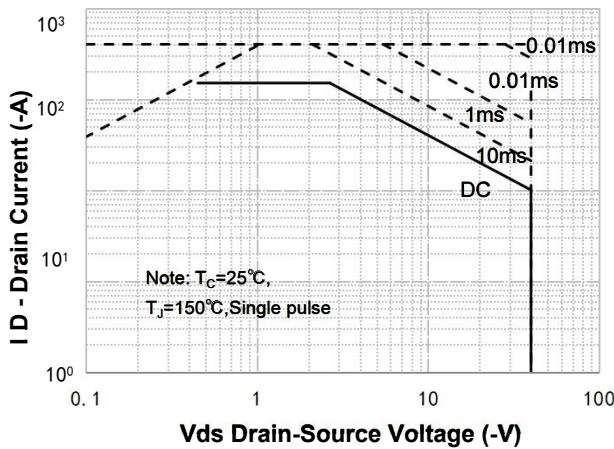

Figure 9. Maximum Safe Operating Area

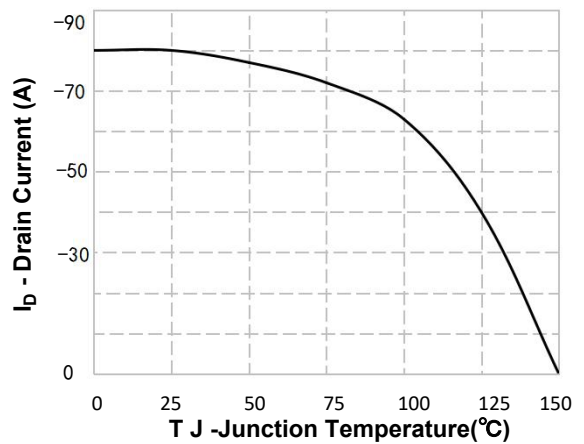
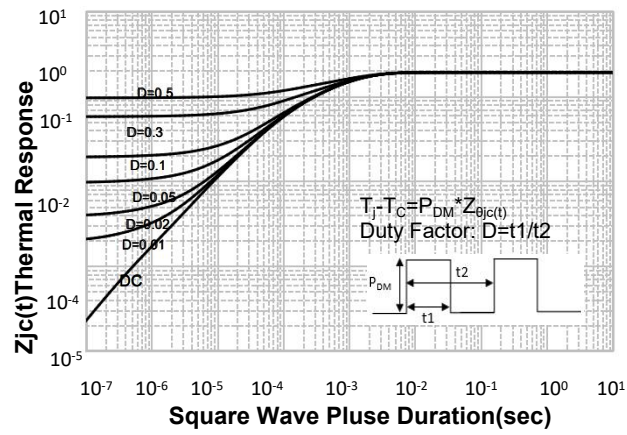

Figure 10. Maximum PContinuous Drain Current vs Case Temperature

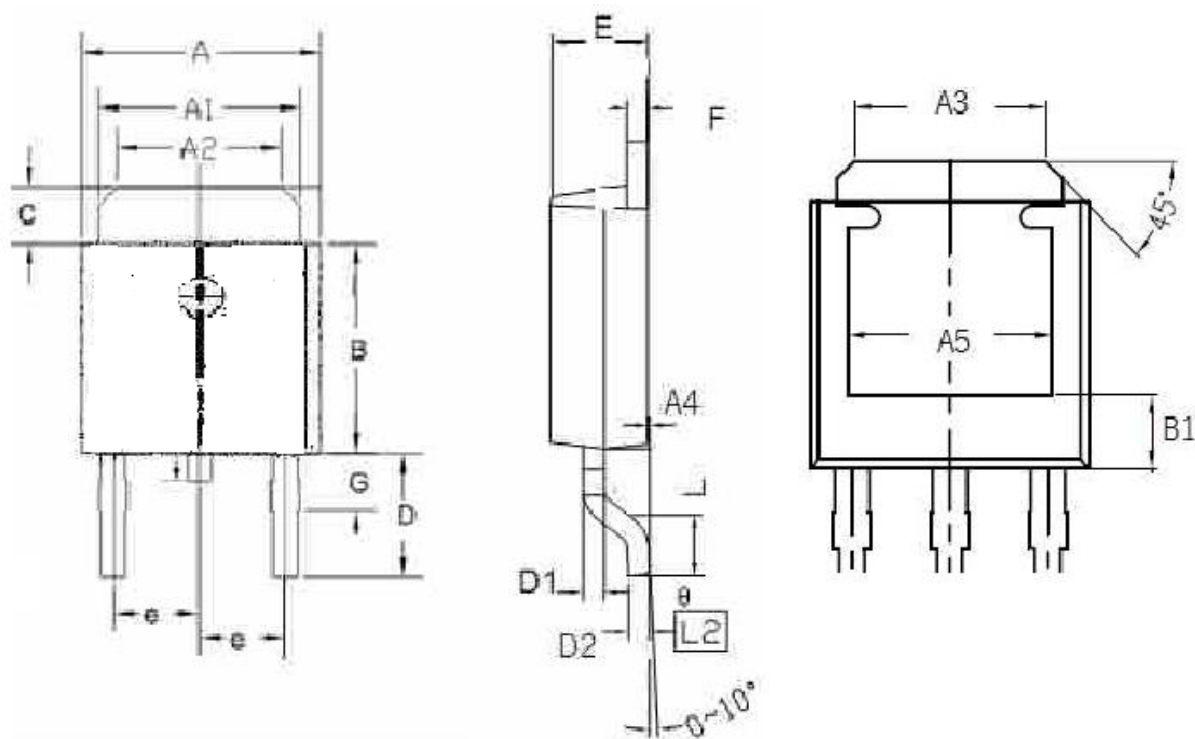

**Figure 11. Transient Thermal Response Curve**

### TO-252 Package Dimensions

UNIT: mm

SYMBOL	min	nom	max	SYMBOL	min	nom	max
A	6.40		6.60	D	2.90		3.10
A1	5.20		5.40	D1	0.45		0.55
A2	4.40		4.60	D2	0.45		0.55
A3	4.40		4.60	e		2.30	
A4	0		0.15	E	2.20		2.40
A5	4.65		4.95	F	0.45		0.55
B	5.90		6.20	G		1.70	
B1	1.57		1.77	L	1.40		1.60
C	0.90		0.96	$\theta$ (度)	0		10.00



## X-ON Electronics

Largest Supplier of Electrical and Electronic Components

*Click to view similar products for [MOSFET](#) category:*

*Click to view products by [SLKORMICRO](#) manufacturer:*

Other Similar products are found below :

[IRFD120](#) [JANTX2N5237](#) [2SK2267\(Q\)](#) [BUK455-60A/B](#) [TK100A10N1,S4X\(S](#) [MIC4420CM-TR](#) [VN1206L](#) [NDP4060](#) [SI4482DY](#)  
[IRS2092STRPBF-EL](#) [IPS70R2K0CEAKMA1](#) [TK31J60W5,S1VQ\(O](#) [TK31J60W,S1VQ\(O](#) [TK16J60W,S1VQ\(O](#) [2SK2614\(TE16L1,Q\)](#)  
[DMN1017UCP3-7](#) [EFC2J004NUZTDG](#) [P85W28HP2F-7071](#) [DMN1053UCP4-7](#) [NTE2384](#) [DMC2700UDMQ-7](#) [DMN2080UCB4-7](#)  
[DMN61D9UWQ-13](#) [US6M2GTR](#) [DMN31D5UDJ-7](#) [DMP22D4UFO-7B](#) [IPS60R3K4CEAKMA1](#) [DMN1006UCA6-7](#) [DMN16M9UCA6-7](#)  
[STF5N65M6](#) [IRF40H233XTMA1](#) [STU5N65M6](#) [DMN6022SSD-13](#) [DMN13M9UCA6-7](#) [DMTH10H4M6SPS-13](#) [IPS60R360PFD7SAKMA1](#)  
[DMN2990UFB-7B](#) [SSM3K35CT,L3F](#) [IPLK60R1K0PFD7ATMA1](#) [2N7002W-G](#) [MCAC30N06Y-TP](#) [IPWS65R035CFD7AXKSA1](#)  
[MCQ7328-TP](#) [SSM3J143TU,LXHF](#) [DMN12M3UCA6-7](#) [PJMF280N65E1\\_T0\\_00201](#) [PJMF380N65E1\\_T0\\_00201](#)  
[PJMF280N60E1\\_T0\\_00201](#) [PJMF600N65E1\\_T0\\_00201](#) [PJMF900N65E1\\_T0\\_00201](#)