

Ultra-Small Package High-Precision Voltage Detector

General Description

The SL61C series is a series of high-precision voltage detectors developed using CMOS process. The detection voltage is fixed internally with an accuracy of $\pm 2.0\%$. Two output forms, Nch open-drain and CMOS output, are available. Ultra-low current consumption and miniature package lineup can meet demand from the portable device applications.

Features

- Ultra-low current consumption 2.0 μA typ. ($V_{in}=1.5\text{V}$)
- High-precision detection voltage $\pm 2.0\%$
- Operating voltage range 0.7 V to 7.0 V
- Detection voltage 1.0V to 6.0 V (0.1 V step)
- Output form Nch open-drain output (Active Low) or CMOS output (Active Low)

Applications

- Battery checkers
- Power failure detectors
- Power monitor for portable equipments such as pagers, calculators, electronic notebooks and remote controllers.
- Constant voltage power monitor for cameras, video equipments and communication devices.
- Power monitor for microcomputers and reset for CPUs.

Package

- SOT23-3L

Typical Application Circuit

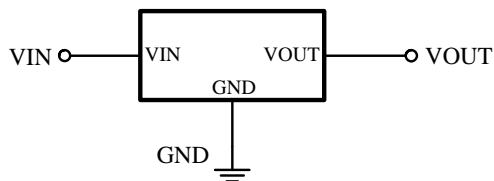

COMS Output

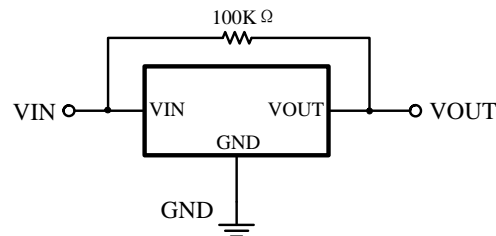

N-ch Open Drain Output

Ordering Information

SL61C ①②③④⑤⑥⑦-⑧

Item	Symbol	Description
①		Output Configuration:
	C	CMOS
	N	N-ch open drain
②③	10-60	Detect Voltage: Eg: 10=1.0V, 38=3.8V
④	0	Output Delay: 0=No delay
⑤	2	Detect Accuracy: $\pm 2\%$
⑥	M	Package Type: SOT23-3L
⑦		Device Orientation:
	R	Embossed Taped(Right)
	L	Embossed Taped(Left)
⑧	G	Green epoxy molding compound

■ Pin Configurations

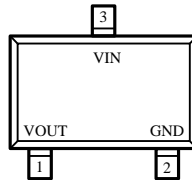

SOT-23-3L
(TOP VIEW)

■ Pin Assignment

Pin No.	Pin name	Pin description
SOT23-3L		
3	VIN	Voltage input pin
2	GND	GND pin
1	VOUT	output pin

■ Marking Rule

- SOT23-3L

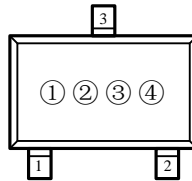

SOT-23-3L
(TOP VIEW)

- ① Represents the product name

Symbol	Product Description
C	SL61C ◆◆◆◆◆◆◆◆

- ② Represents the Output configuration and detect voltage range

Designator	Output Configuration	Voltage Range (V)
A	CMOS	0.1~3.0
B	CMOS	3.1~6.0
N	OPEN DRAIN	0.1~3.0
P	OPEN DRAIN	3.1~6.0

③ Represents the detect voltage

Designator	Detect Voltage (V)	
0	-	3.1
1	-	3.2
2	-	3.3
3	-	3.4
4	-	3.5
5	-	3.6
6	-	3.7
7	-	3.8
8	0.9	3.9
9	1.0	4
A	1.1	4.1
B	1.2	4.2
C	1.3	4.3
D	1.4	4.4
E	1.5	4.5

Designator	Detect Voltage (V)	
F	1.6	4.6
H	1.7	4.7
K	1.8	4.8
L	1.9	4.9
M	2	5
N	2.1	
P	2.2	
R	2.3	
S	2.4	
T	2.5	
U	2.6	
V	2.7	
X	2.8	
Y	2.9	
Z	3	

④ Based on internal standards

0~9, A~Z repeated (G, I, J, O, Q, W are excepted)

■ Function Block Diagram

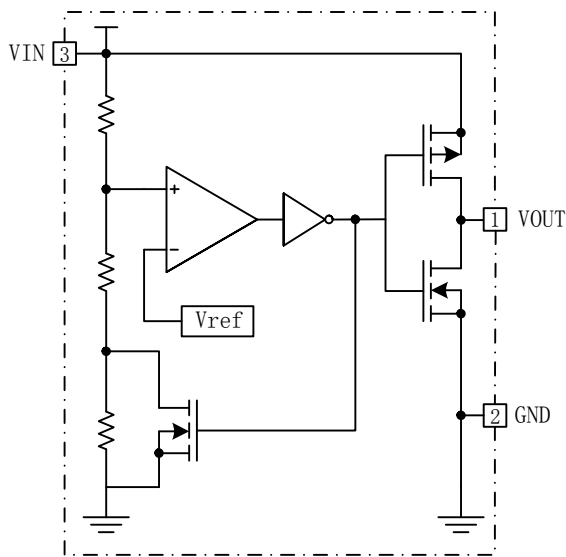

COMS Output

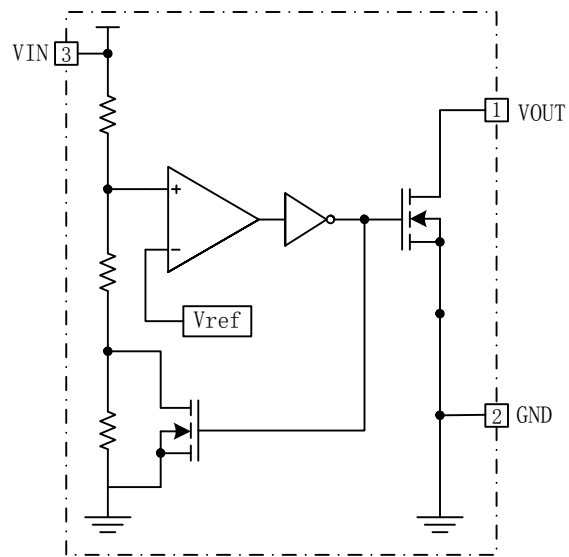

N-ch Open Drain Output

■ Absolute Maximum Ratings (Ta=25°C)

Item	Symbol	Absolute maximum ratings	unit	
Power supply voltage	Vin	8	V	
Output current	Iout	50	mA	
Output voltage	CMOS	GND-0.3~Vin+0.3	V	
	N-ch	GND-0.3~8		
Power dissipation	SOT23-3L	Pd	150	mW
Operating ambient temperature	Topr	-40~+85	°C	

■ Electrical Characteristics

(VDF (T) = 1.0 to 6.0V ± 2% Ta=25°C)

Item	Symbol	Condition	Min.	Typ.	Max.	Unit	Test Circuit	
Detection voltage	VDF	-	VDF x0.98	VDF	VDF x1.02	V	1	
Hysteresis Voltage	VHYS	-	VDF x0.02	VDF x0.05	VDF x0.08	V	1	
Current consumption	Iss	Vin=1.0V	-	2.0	2.2	μA	2	
		=1.5V	-	2.0	2.4			
		=2.0V	-	2.0	2.8			
		=3.0V	-	2.0	3.1			
		=4.0V	-	2.0	3.3			
		=5.0V	-	2.0	3.7			
Operating voltage	Vin	VDF=1.0~6.0V	0.7	-	7	V	1	
Output current	Iout	Nch-Vds=0.5V	Vin=1.0V	1.0	2.2	-	mA	3
			Vin=1.5V	2.0	5.7	-		
			Vin=2.0V	3.0	7.7	-		
			Vin=3.0V	5.0	10.1	-		
			Vin=4.0V	6.0	11.5	-		
			Vin=5.0V	7.0	13.0	-		
		Pch vds=2.1V, Vin=8.0V	-	-10	-2	4		
Temperature coefficient	-	-40~+85°C	-	±100	-	ppm/°C	1	

■ Test Circuit

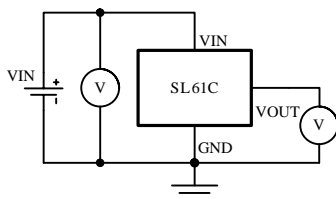

Circuit 1
(CMOS Output)

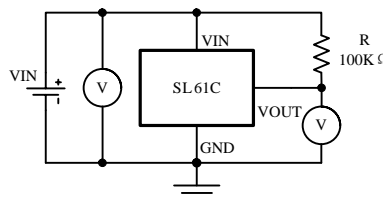

Circuit 1
(N-ch Open Drain Output)

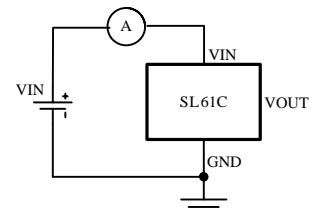

Circuit 2

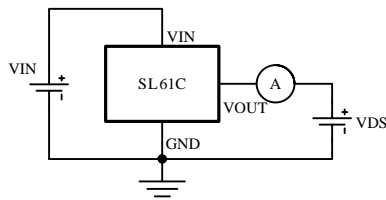

Circuit 3

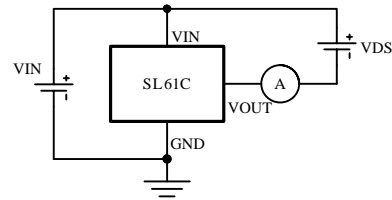

Circuit 4

■ Timing Chart

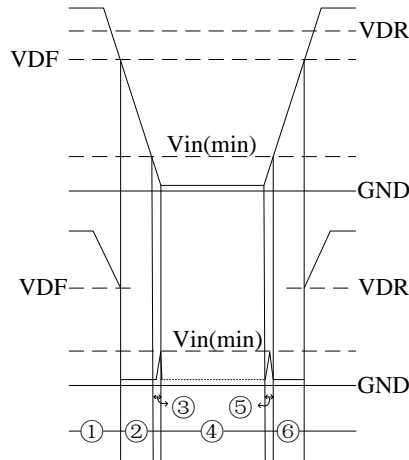

■ Operation

- ① When the power supply voltage (VDD) is higher than the release voltage (VDF), the Nch transistor is OFF and the Pch transistor is ON to provide VDD (high) at the output.
- ② When the power supply voltage (VDD) is lower than the release voltage (VDF), the Nch transistor is ON and the Pch transistor is OFF to provide GND (low) at the output.
- ③ When the VDD falls below the minimum operating voltage, the output becomes undefined, or goes to the VDD when the output is pulled up to the VDD.
- ④ The GND level appears when the VDD is GND level.
- ⑤ The GND level appears when the VDD rises above the minimum operating voltage. The GND level still appears even when the VDD surpasses $-VDF$, as long as it does not exceed the release voltage $+VDF$.
- ⑥ When the VDD rises above $+VDF$ the Nch transistor becomes OFF and the Pch transistor becomes ON to provide VDD level at the output.

■ Application Circuit Examples

● Microcomputer Reset Circuits

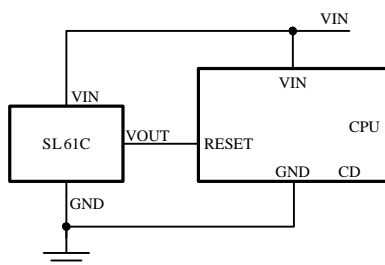

Input voltage equal to CPU input voltage
(CMOS Output)

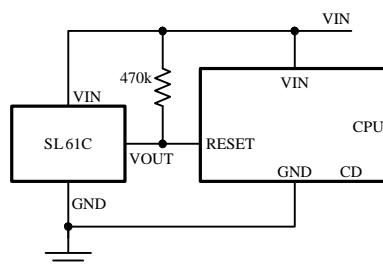

Input voltage equal to CPU input voltage
(N-ch open drain output)

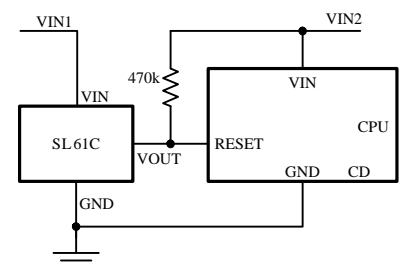

Input voltage is not equal to CPU input voltage
(N-ch open drain output)

- Power-on Reset Circuit

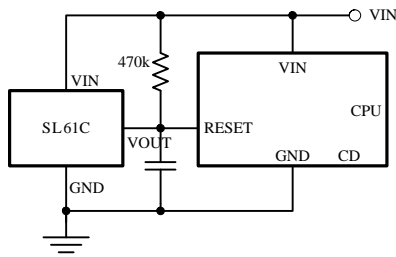

(COMS Output)

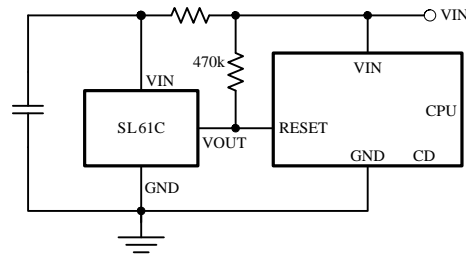

(N-ch Open Drain Output)

- Memory back-up circuit

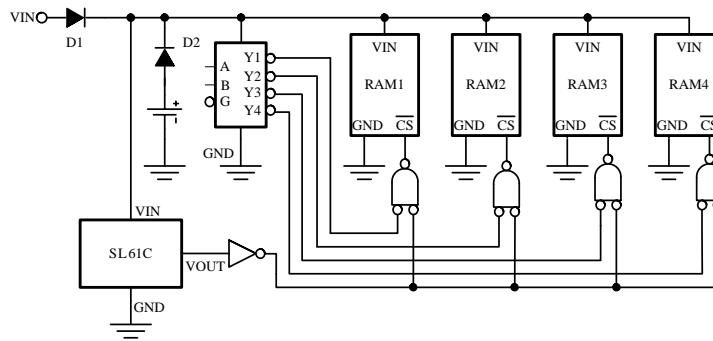

- Power failure detectors

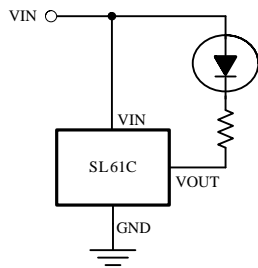

- Window Comparator Circuit

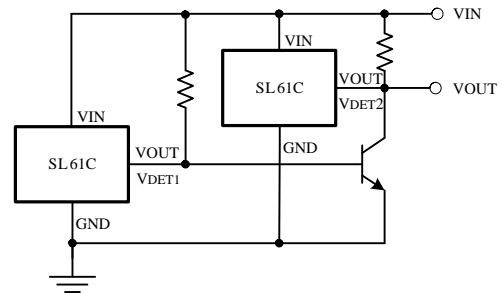

- Overcharge protect circuit

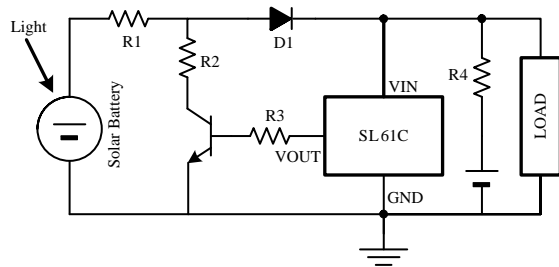

- Detector Adjustable Circuit

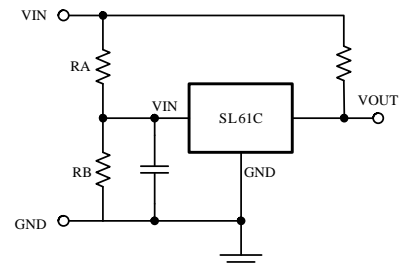

■ Typical Performance Characteristics

1. Supply Current VS Input Voltage

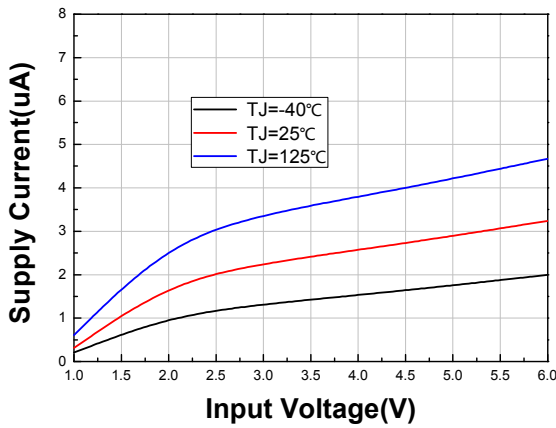

2. Output Current VS VDS

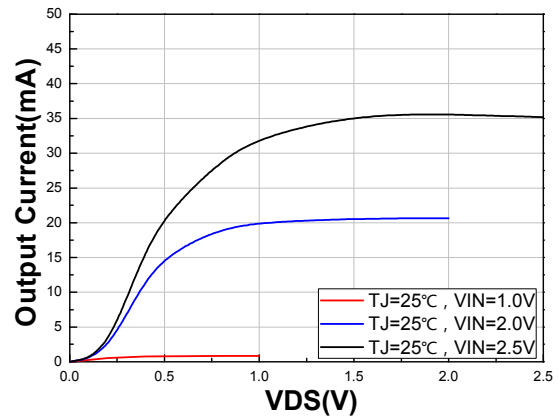

3. Output Current VS Input Voltage (LN61CN2702MR-G)

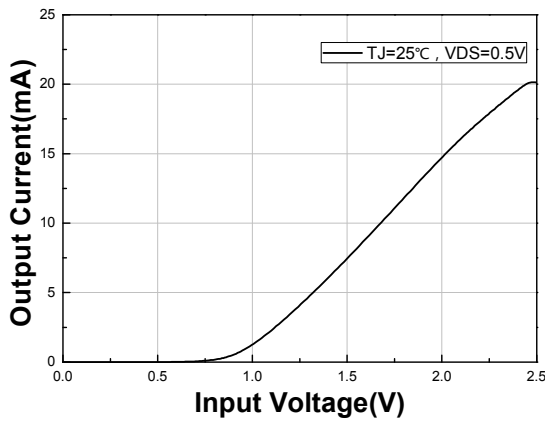

4. Output Voltage VS Input Voltage (LN61CN2702MR-G)

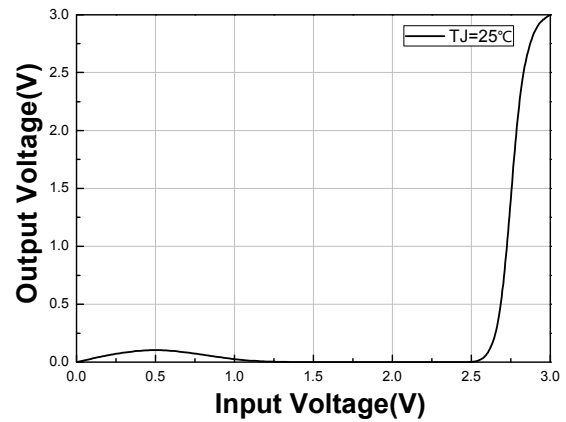

5. VDF VS Temperature

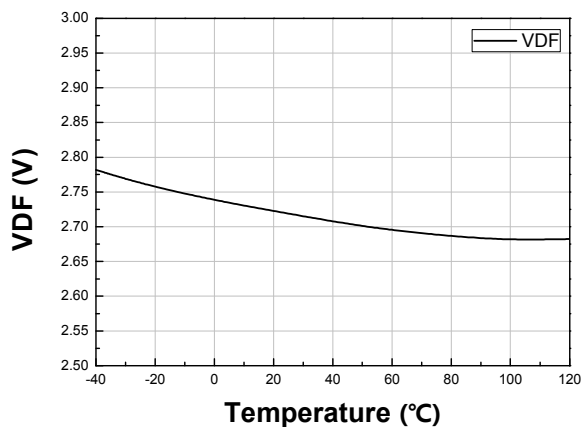

6. Release voltage VS Temperature

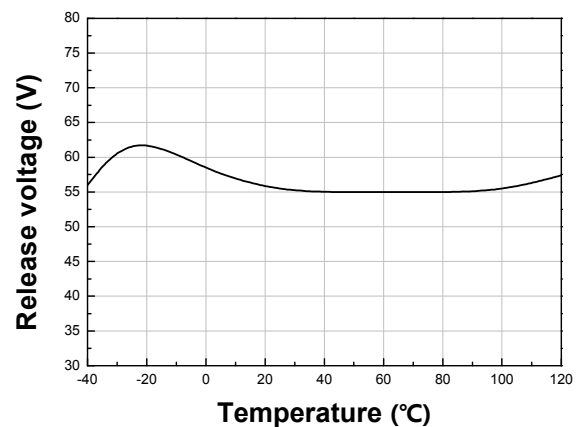

■ Package

- SOT23-3L

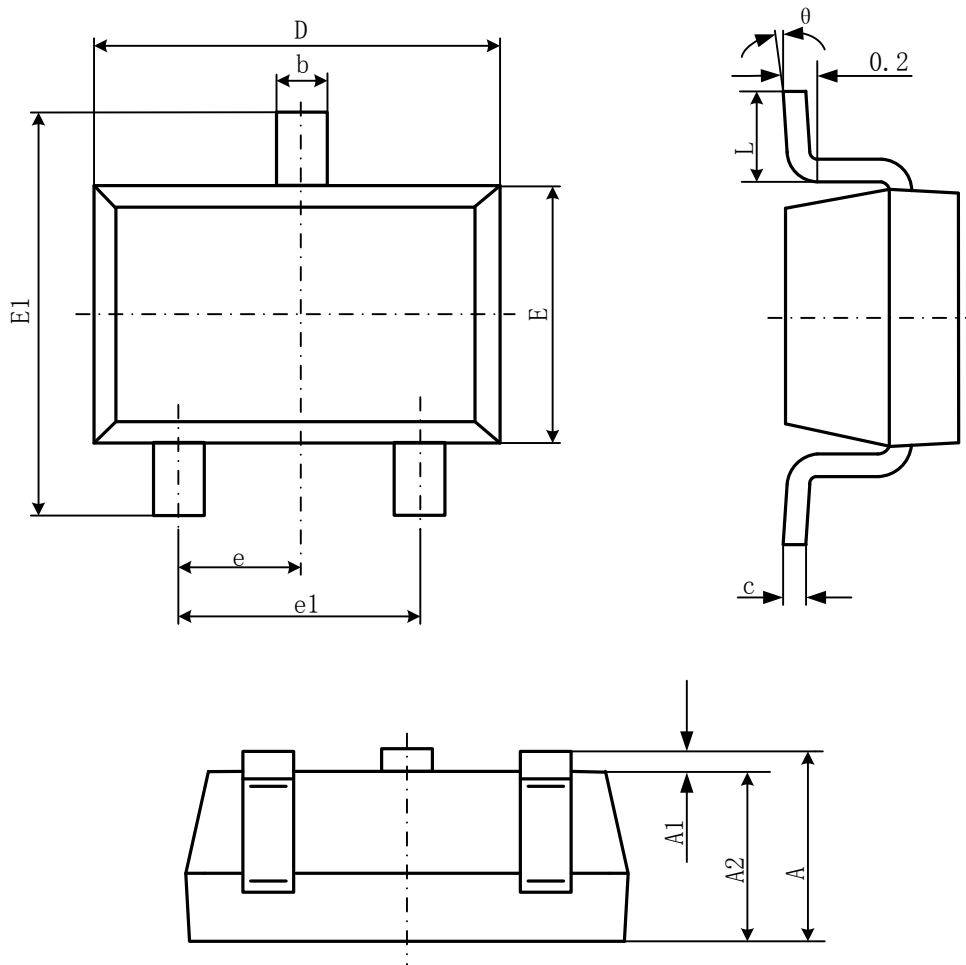

Symbol	Dimensions In Millimeters		Dimensions In Inches	
	Min	Max	Min	Max
A	1.050	1.250	0.041	0.049
A1	0.000	0.100	0.000	0.004
A2	1.050	1.150	0.041	0.045
b	0.300	0.500	0.012	0.020
c	0.100	0.200	0.004	0.008
D	2.820	3.020	0.111	0.119
E	1.500	1.700	0.059	0.067
E1	2.650	2.950	0.104	0.116
e	0.950(BSC)		0.037(BSC)	
e1	1.800	2.000	0.071	0.079
L	0.300	0.600	0.012	0.024
θ	0°	8°	0°	8°

X-ON Electronics

Largest Supplier of Electrical and Electronic Components

Click to view similar products for [Supervisory Circuits](#) category:

Click to view products by [SLKORMICRO](#) manufacturer:

Other Similar products are found below :

[NCP304LSQ40T1G](#) [CAT1161LI-25-G](#) [CAT853STBI-T3](#) [TC54VN2402EMB713](#) [MCP1316T-44NE/OT](#) [MCP1316MT-45GE/OT](#)
[MCP1316MT-23LI/OT](#) [DS1232L](#) [NCV302HSN45T1G](#) [MCP1316T-23LI/OT](#) [PT7M6130NLTA3EX](#) [S-1000N28-I4T1U](#) [CAT1161LI-28-G](#)
[MCP1321T-29AE/OT](#) [MCP1319MT-47QE/OT](#) [S-1000N23-I4T1U](#) [S-1000N19-I4T1U](#) [CAT824UTDI-GT3](#) [TC54VC2502ECB713](#)
[PT7M6133NLTA3EX](#) [PT7M6127NLTA3EX](#) [BD48E23G-TR](#) [BD48E49G-TR](#) [BD48E52G-TR](#) [MP6412GQGU-Z](#) [XC61GN2502HR-G](#)
[HG810RM3/TR](#) [ME2808A33XG](#) [ME2801A33M3G](#) [SGM809B-RXN3LG/TR](#) [HT7033S](#) [UM803RS](#) [UM805RE](#) [BL8506-40CRM](#) [SSP54123](#)
[SSP61CN1902MR](#) [Aip54123](#) [MAX809C263NR](#) [HE61CN2402MR](#) [SL61CC2702MR-G](#) [UM810MS](#) [MAX809C293NR](#) [MAX809C308NR](#)
[HE61CN2702MR](#) [UM811SE](#) [XC61CN1902MR](#) [BD48K34G-TL](#) [BL8506-20CRM](#) [CN825R](#) [XC61CC1502MR](#)