

300mA Low-Dropout Linear Regulator

Description

The SL6206 series products are high performance and low dropout linear regulators. The SL6206 series products support maximum 300 mA output current with low quiescent current and high PSRR. The SL6206 series products is stable with ceramic output capacitor from 2.2 μF to 10 μF .

The SL6206 series products have a high PSRR with 60 dB at 1 KHz. This feature makes SL6206 series products very suitable for power-sensitive applications with high noise from previous stage power supply. As low as 50 μA quiescent current and shutdown current makes the SL6206 series products ideal choices for portable devices with battery power supply.

Applications

- Handheld Devices with Battery Power Supply
- Video Surveillance
- Wireless and IoT modules

Features

- Input Voltage Range: 2.5 V to 5.5 V
- Output Voltage Options:
 - ◆ Fixed Voltage: 1.2 V, 1.8 V, 2.5 V, 2.8 V, 3 V, 3.3 V
 - ◆ Adjustable Voltage: 0.8 V to 5 V
- $\pm 2\%$ Output Accuracy Through Operating Conditions
- Maximum Output Current: 300 mA
- Low Dropout Voltage: 200 mV at 300 mA
- Low Quiescent Current and Shutdown Current
- Foldback Current Limit and Thermal Protection
- Stable with 2.2 μF Ceramic Capacitor
- Soft-start Limits Input Current Surge During Enable
- Thermal Shutdown Protection
- Junction Temperature Range: -40°C to $+125^{\circ}\text{C}$

Typical Application Schematic

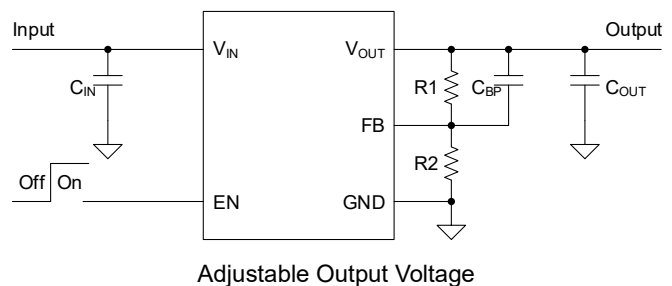
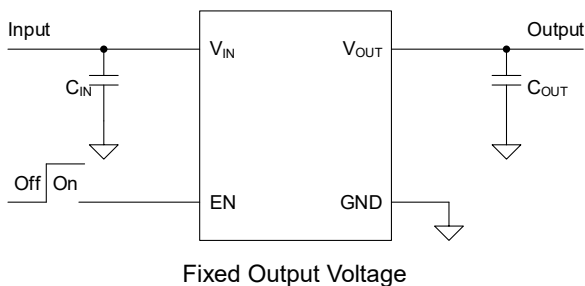

Product Family Table

Part Number	Output Voltage	Package	Transport Media, Quantity
SL6206-ADJMR	Adjustable (0.8 V ~ 5 V)	SOT23-5	Tape and Reel, 3,000
SL6206-12MR	Fixed 1.2 V	SOT23-5	Tape and Reel, 3,000
SL6206-18MR	Fixed 1.8 V	SOT23-5	Tape and Reel, 3,000
SL6206-25MR	Fixed 2.5 V	SOT23-5	Tape and Reel, 3,000
SL6206-28MR	Fixed 2.8 V	SOT23-5	Tape and Reel, 3,000
SL6206-30MR	Fixed 3.0 V	SOT23-5	Tape and Reel, 3,000
SL6206-33MR	Fixed 3.3 V	SOT23-5	Tape and Reel, 3,000

Pin Configuration and Functions

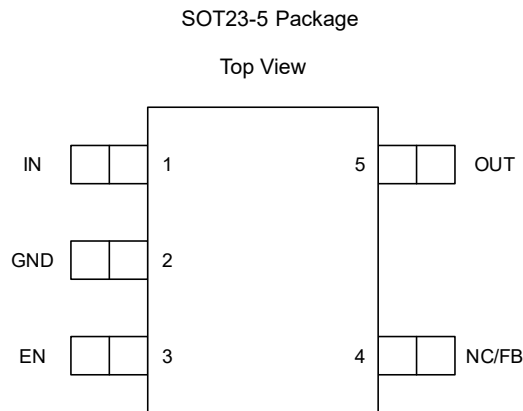

Pin Functions

Name	Pin Number	I/O	Description
IN	1	I	Input voltage pin. Bypass IN to GND with a 1 μ F or greater capacitor.
OUT	5	O	Regulated output voltage pin. Bypass OUT to GND with a 2.2 μ F or greater capacitor.
EN	3	I	Regulator enable pin. Drive EN high to turn on the regulator; drive EN low to turn off the regulator. For automatic startup, connect EN to IN directly.
GND	2	-	Ground reference pin. Connect GND pin to PCB ground plane directly.
NC	4	-	No connection.
FB	4	I	Output feedback pin (Adjustable version only). Connect to a resistor divider to adjust the output voltage.

Note: Thermal pad must be connected to PCB ground plane to maximum the thermal performance.

Specifications

Absolute Maximum Ratings

Parameters		Min	Max	Unit
V_{IN}, V_{EN}	Input Voltage	-0.3	6	V
V_{OUT}	Output Voltage	-0.3	6	V
V_{FB}	Feedback Voltage (Adjustable version only)	-0.3	6	V
T_J	Junction Temperature Range	-40	150	°C
T_{STG}	Storage Temperature Range	-65	150	°C
T_L	Lead Temperature (Soldering 10 sec)		260	°C

(1) Stresses beyond those listed under Absolute Maximum Ratings may cause permanent damage to the device. Exposure to any Absolute Maximum Rating condition for extended periods may affect device reliability and lifetime.

(2) All voltage values are with respect to GND.

ESD, Electrostatic Discharge Protection

Symbol	Parameter	Condition	Minimum Level	Unit
HBM	Human Body Model ESD	ANSI/ESDA/JEDEC JS-001	±8	kV
CDM	Charged Device Model ESD	ANSI/ESDA/JEDEC JS-002	±2	kV

Recommended Operating Conditions

Parameters		Min	Max	Unit
V_{IN}	Input Voltage	2.5	5.5	V
V_{EN}	Enable Voltage	0	V_{IN}	V
V_{OUT}	Output Voltage	0	5	V
V_{FB}	Feedback Voltage (Adjustable version only)	0	V_{OUT}	V
I_{OUT}	Output Current	0	300	mA
T_J	Junction Temperature Range	-40	125	°C

Electrical Characteristics

All test condition: $V_{IN} = V_{OUT(NOM)} + 0.5V$ or $2.5V$, whichever is greater; $C_{OUT} = 2.2 \mu F$, $T_A = +25^\circ C$, unless otherwise noted.

Symbol	Parameter	Conditions	Min	Typ	Max	Unit
Supply Input Voltage and Current						
V_{IN}	Input voltage range		2.5		5.5	V
I_{GND}	Ground pin current	$I_{OUT} = 0 \text{ mA}$		50		μA
I_{SHDN}	Shutdown current	EN = GND		1		μA
UVLO	V_{IN} under-voltage lock-out	V_{IN} rising		2		V
		Hysteresis		0.2		V
Enable Input Voltage and Current						
$V_{IH(EN)}$	EN logic-input high level (enable)		1.2		V_{IN}	V
$V_{IL(EN)}$	EN logic-input low level (disable)		0		0.4	V
I_{EN}	EN pin leakage current	EN = 5V		1		μA
Regulated Output Voltage and Current						
V_{OUT}	Output voltage accuracy		-2%		2%	
V_{FB}	Feedback pin voltage	ADJ version only		0.8		V
ΔV_{OUT}	Line regulation	$V_{IN} = V_{OUT(NOM)} + 0.5V$ or $2.5V$ to $5.5V$, $I_{OUT} = 1 \text{ mA}$		4	10	mV
	Load regulation	$I_{OUT} = 1 \text{ mA}$ to 300 mA		25		mV
$V_{DO}^{(1)}$	Dropout voltage	$V_{IN} = 0.98 \times V_{OUT(NOM)}$, $I_{OUT} = 100 \text{ mA}$		80		mV
		$V_{IN} = 0.98 \times V_{OUT(NOM)}$, $I_{OUT} = 300 \text{ mA}$		240	300	mV
I_{OUT}	Output current	V_{OUT} in regulation	0		300	mA
I_{CL}	Output current limit	$V_{OUT} = 0.9 \times V_{OUT(NOM)}$	350		1200	mA
PSRR	Power supply rejection ratio	$I_{OUT} = 100 \text{ mA}$, $f = 1 \text{ kHz}$		60		dB
		$I_{OUT} = 100 \text{ mA}$, $f = 1 \text{ MHz}$		40		dB
V_N	Output noise voltage	$I_{OUT} = 100 \text{ mA}$, BW = 100Hz to 80 kHz		150		μV_{RMS}
$t_{STR}^{(2)}$	Start-up time	$I_{OUT} = 500 \text{ mA}$, $C_{OUT} = 2.2 \mu F$		150		μs
		$I_{OUT} = 500 \text{ mA}$, $C_{OUT} = 2.2 \mu F$, $C_{BP} = 100 \text{ nF}$		15		ms
Temperature Range						
T_{SD}	Thermal shutdown temperature			170		$^\circ C$
	Thermal shutdown hysteresis			30		$^\circ C$

(1) Dropout voltage is the minimum input to output voltage differential needed to maintain regulation at a specified output current. In dropout, the output voltage will be equal to: $V_{IN} - V_{DROPOUT}$.

(2) Start-up time from EN assertion to $0.98 \times V_{OUT(NOM)}$.

Typical Performance Characteristics

All test condition: $V_{IN} = V_{OUT(NOM)} + 0.5V$ or $2.5V$, whichever is greater; $C_{OUT} = 2.2 \mu F$, $T_A = +25^\circ C$, unless otherwise noted.

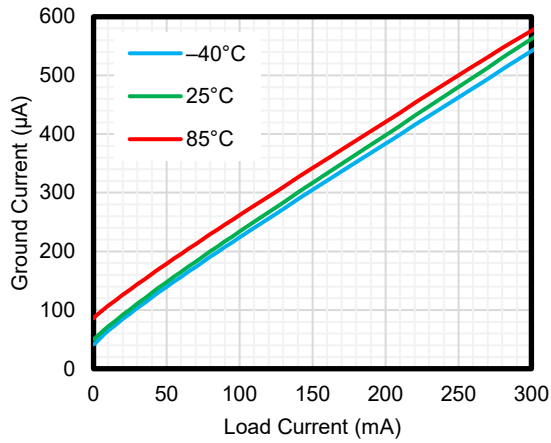

Figure 1 Quiescent Current vs Output Current

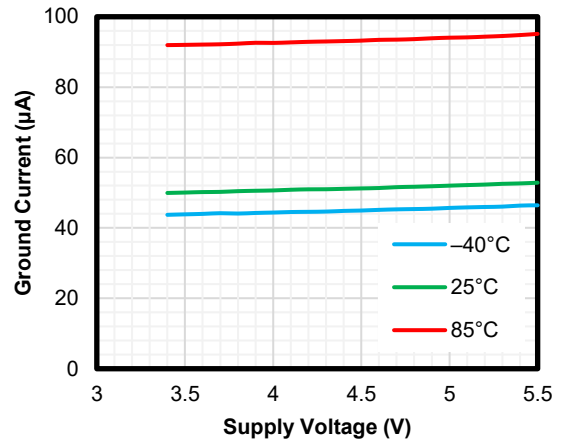

Figure 2 Quiescent Current vs Supply Voltage

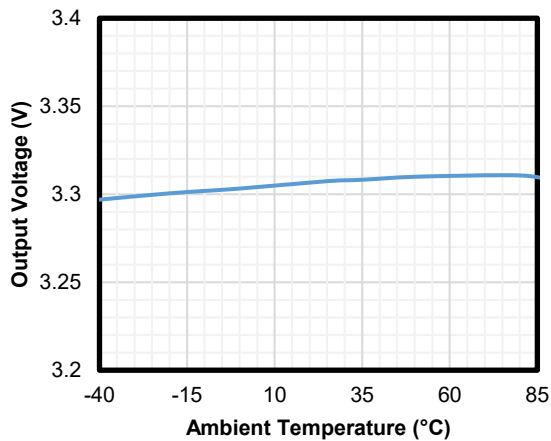

Figure 3 Output Accuracy vs Ambient Temperature

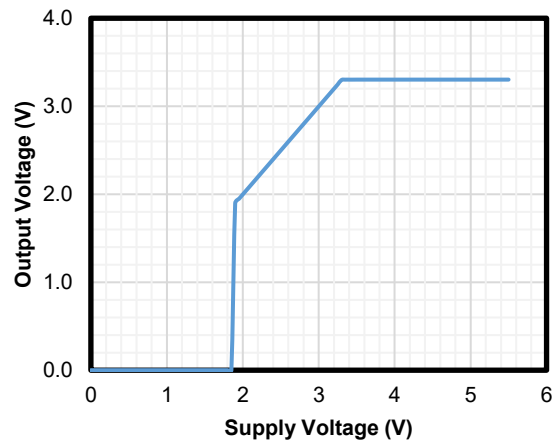

Figure 4 Output Voltage vs Supply Voltage

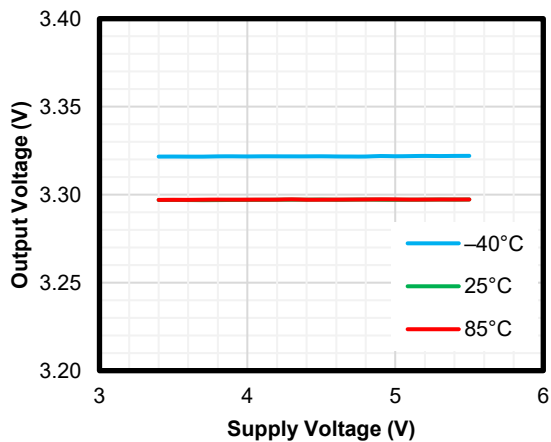

Figure 5. Line Regulation

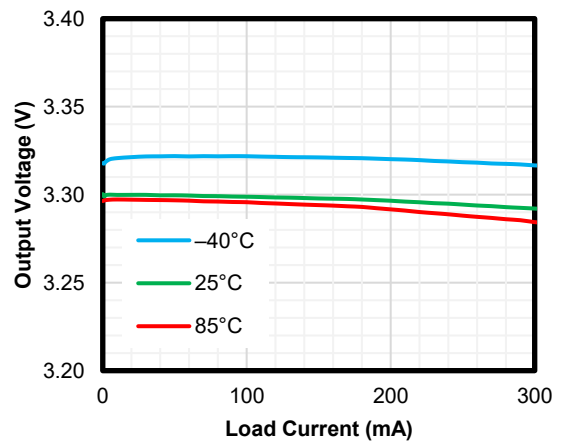
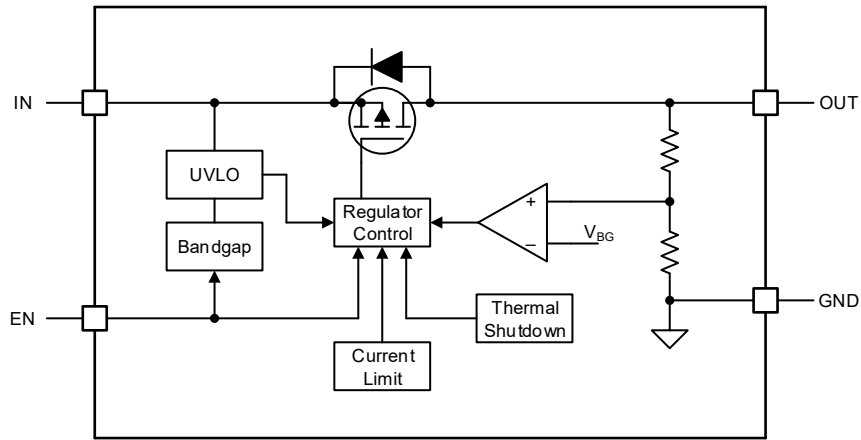
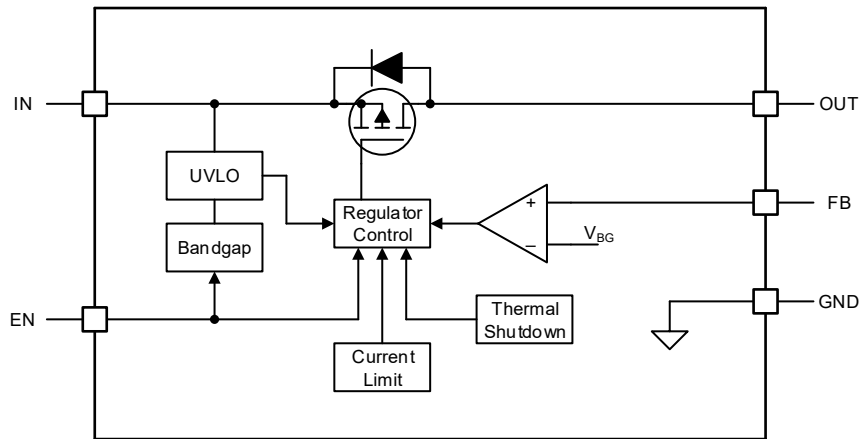

Figure 6. Load Regulation

Functional Block Diagram



SL6206 Series Fixed Output Version



SL6206 Series Adjustable Output Version

Package Outline Dimensions

SOT23-5

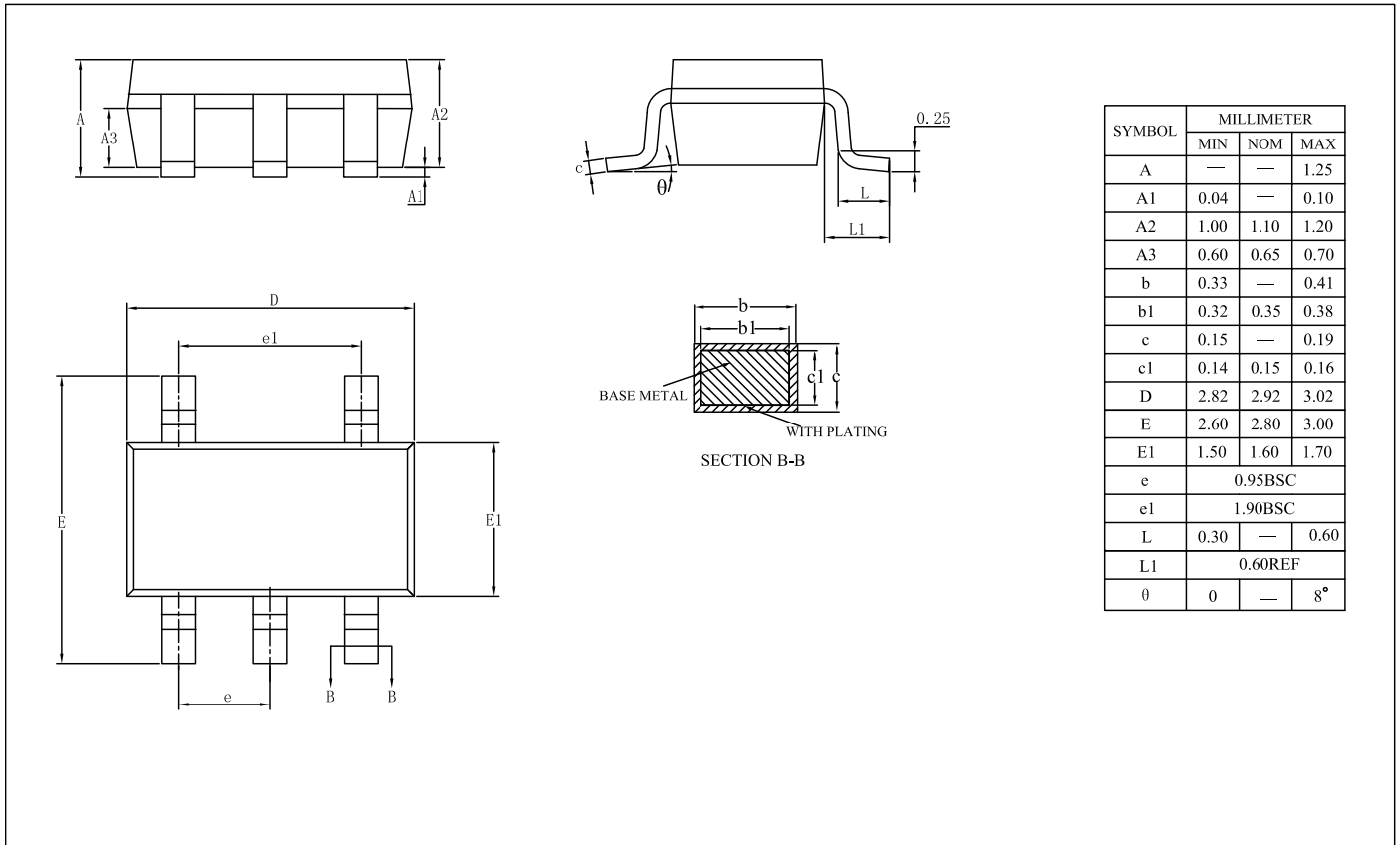

X-ON Electronics

Largest Supplier of Electrical and Electronic Components

Click to view similar products for [slkormicro](#) manufacturer:

Other Similar products are found below :

[SS54](#) [LZ1E331M-CRF10](#) [LZ1V101M-CRE77](#) [SL78L09](#) [SL17N06D](#) [LZ1V221M-CRF10](#) [SL80N10](#) [GBP410](#) [TIP122](#) [SL130N04Q](#)
[3B2A474JD5B0072095045ES0](#) [LM2575S-5.0](#) [SL100N08](#) [SL75N06Q](#) [SL60N06](#) [LM317](#) [SL48N08Q](#) [SL65N10Q](#) [SL60N10Q](#) [MB6F](#)
[3B2A103JD1B0072065025ES0](#) [SL40T65FL](#) [A09B1D471KQ0T0S0N0](#) [N06S1B560KN0B0S0N0](#) [BC807-25](#) [MMSZ5256B](#)
[W08E1D102MN0B0S0N0](#) [T10E1D222MN0B0S0N0](#) [ZMM24](#) [BTA26-800B](#) [SS26](#) [LZ0J471M-CRF10](#) [SL11N65CF](#) [SL494CNS](#) [BZT52C18](#)
[SL13N50FS](#) [SL21N65CF](#) [MMSZ5240B](#) [MMSZ5223B](#) [ZMM27](#) [ZMM4V3](#) [R08F1B472MQ0T0S0N0](#) [SL7824](#) [LZ0J102M-CRF10](#) [SS36C](#)
[2SC2078](#) [2SC3357](#) [RE](#) [3B2A102JD5B0072065025ES0](#) [C1815](#) [S07S1E330KQ0T0S0N0](#)