

N-Channel Power MOSFET

General Description

- Very low on-resistance $R_{DS(ON)}$
- Low Gate Charge
- Excellent Gate Charge x $R_{DS(ON)}$ Product

Applications

- High Frequency Switching and Synchronous Rectification

Product Summary

V_{DS}	100V
I_D	65A
$R_{DS(ON)}$ (at $V_{GS}=10V$)	< 14m Ω (Max)
$R_{DS(ON)}$ (at $V_{GS}=4.5V$)	< 17m Ω (Max)

100% DVDS Tested
 100% UIS Tested
 100% Rg Tested

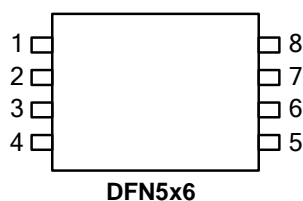

Part Number	Package Type	Form	Marking
SL65N10Q	DFN5x6	Tape & Reel	SL65N10Q

Absolute Maximum Ratings ($T_A = 25^\circ\text{C}$ unless otherwise noted)

Parameter	Symbol	Maximum	Units
Drain-Source Voltage	V_{DS}	100	V
Gate-Source Voltage	V_{GS}	± 20	V
Continuous Drain Current	I_D	Silicon Limited	65
		$T_C = 100^\circ\text{C}$ ^B	40
Pulsed Drain Current ^A	I_{DM}	130	A
Avalanche Current ^A	I_{AS}	60	A
Single Pulse Avalanche Energy	E_{AS}	180	mJ
Power Dissipation ^C	P_D	$T_C = 25^\circ\text{C}$	89
		$T_A = 25^\circ\text{C}$	2.5
Junction and Storage Temperature Range	T_J, T_{STG}	-55 to 150	$^\circ\text{C}$

Thermal Characteristics

Parameter	Symbol	Maximum	Units
Maximum Junction-to-Case	$R_{\theta JC}$	62	$^\circ\text{C}/\text{W}$
Maximum Junction-to-Ambient	$R_{\theta JA}$	1.4	

Electrical Characteristics @ $T_j=25^{\circ}\text{C}$ (unless otherwise specified)

Symbol	Parameter	Test Conditions	Min.	Typ.	Max.	Units
BV_{DSS}	Drain-Source Breakdown Voltage	$V_{GS}=0V, I_D=10mA$	100	-	-	V
$R_{DS(ON)}$	Static Drain-Source On-Resistance ²	$V_{GS}=10V, I_D=20A$	-	-	14	$m\Omega$
		$V_{GS}=4.5V, I_D=20A$	-	-	17	$m\Omega$
$V_{GS(th)}$	Gate Threshold Voltage	$V_{DS}=V_{GS}, I_D=250\mu A$	1.2	-	2.4	V
g_{fs}	Forward Transconductance	$V_{DS}=10V, I_D=20A$	-	30	-	S
I_{DSS}	Drain-Source Leakage Current	$V_{DS}=20V, V_{GS}=0V$	-	-	1	μA
I_{GSS}	Gate-Source Leakage	$V_{GS}=\pm 20V, V_{DS}=0V$	-	-	± 100	nA
Q_g	Total Gate Charge	$I_D=20A$	-	75	-	nC
Q_{gs}	Gate-Source Charge	$V_{DS}=15V$	-	15	-	nC
Q_{gd}	Gate-Drain ("Miller") Charge	$V_{GS}=4.5V$	-	20	-	nC
$t_{d(on)}$	Turn-on Delay Time	$V_{DS}=15V$	-	18	-	ns
t_r	Rise Time	$I_D=1A$	-	8	-	ns
$t_{d(off)}$	Turn-off Delay Time	$R_G=3.3\Omega$	-	58	-	ns
t_f	Fall Time	$V_{GS}=10V$	-	15	-	ns
C_{iss}	Input Capacitance	$V_{GS}=0V$	-	4708	-	pF
C_{oss}	Output Capacitance	$V_{DS}=15V$	-	326	-	pF
C_{rss}	Reverse Transfer Capacitance	$f=1.0MHz$	-	247	-	pF
R_g	Gate Resistance	$f=1.0MHz$	-	1.6	-	Ω

Source-Drain Diode

Symbol	Parameter	Test Conditions	Min.	Typ.	Max.	Units
V_{SD}	Forward On Voltage ²	$I_S=20A, V_{GS}=0V$	-	-	1.2	V
t_{rr}	Reverse Recovery Time	$I_S=20A, V_{GS}=0V,$	-	24	-	ns
Q_{rr}	Reverse Recovery Charge	$di/dt=100A/\mu s$	-	30	-	nC

Typical Characteristics

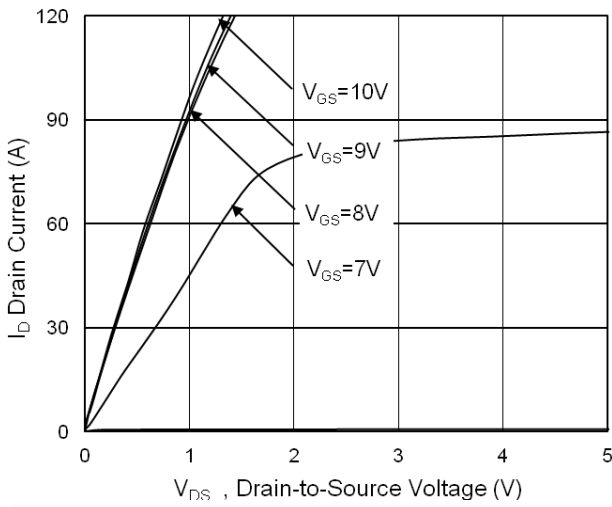

Fig.1 Typical Output Characteristics

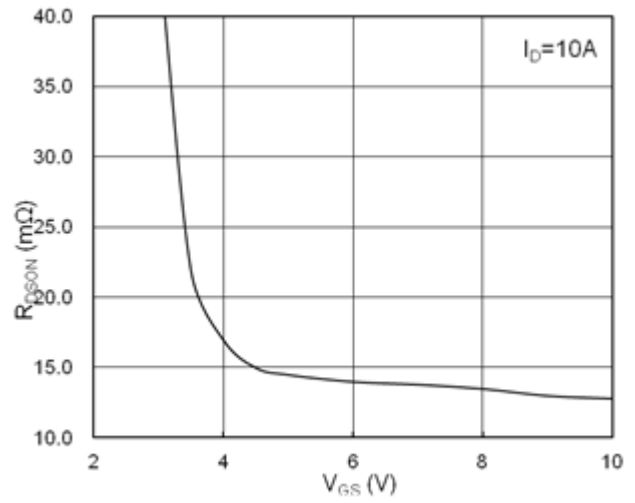

Fig.2 On-Resistance v.s Gate-Source

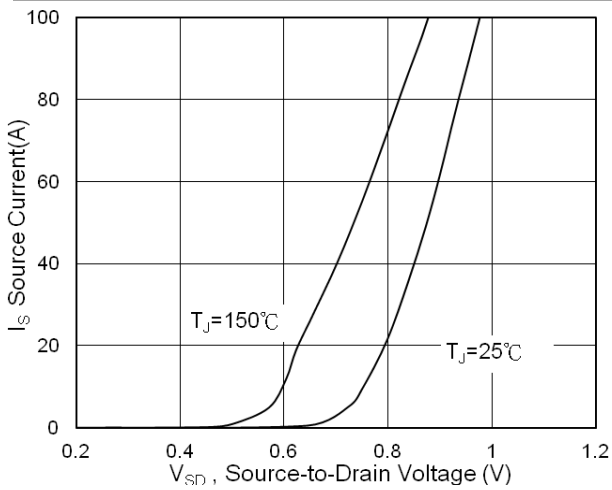

Fig.3 Forward Characteristics of Reverse

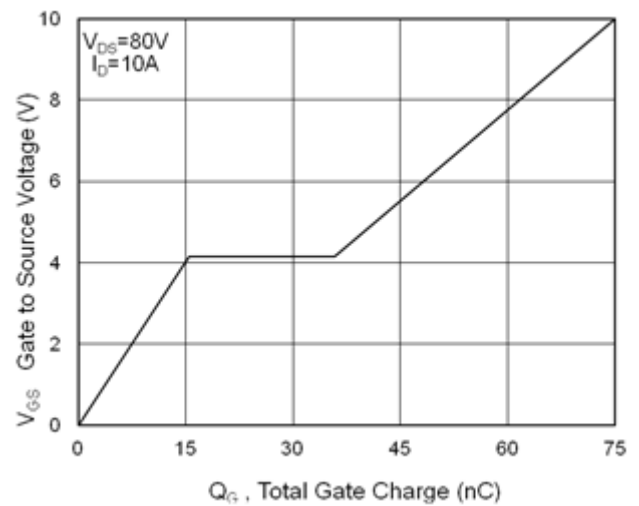

Fig.4 Gate-Charge Characteristics

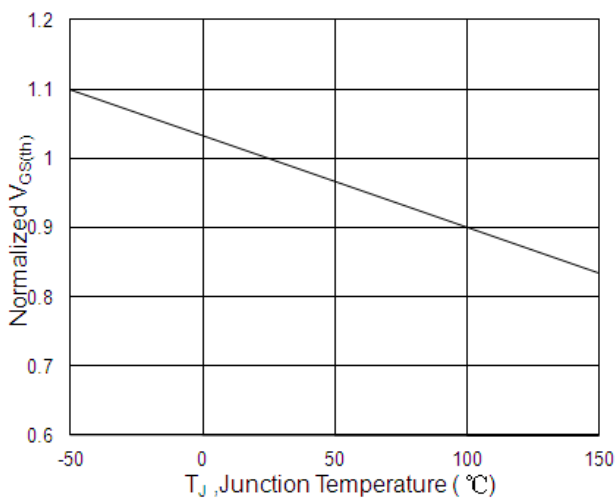

Fig.5 Normalized $V_{GS(th)}$ vs. T_J

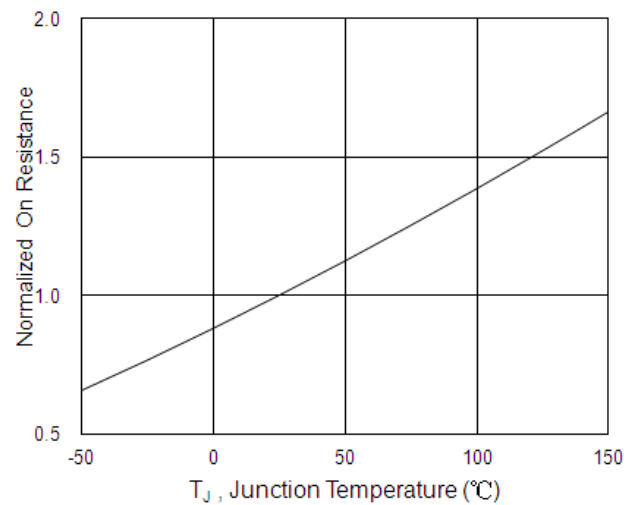

Fig.6 Normalized $R_{DS(on)}$ vs. T_J

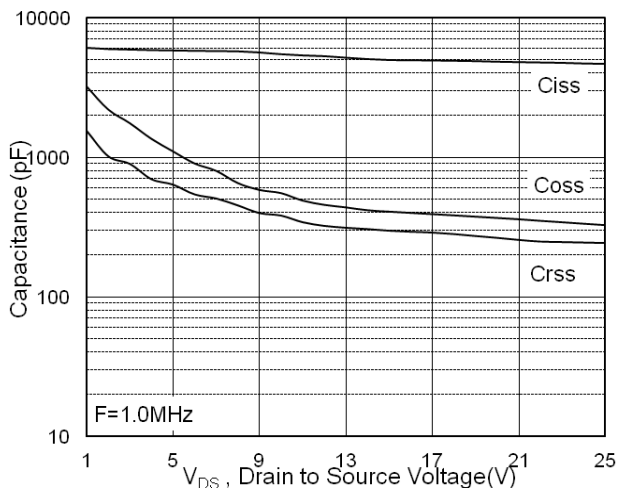

Fig.7 Capacitance

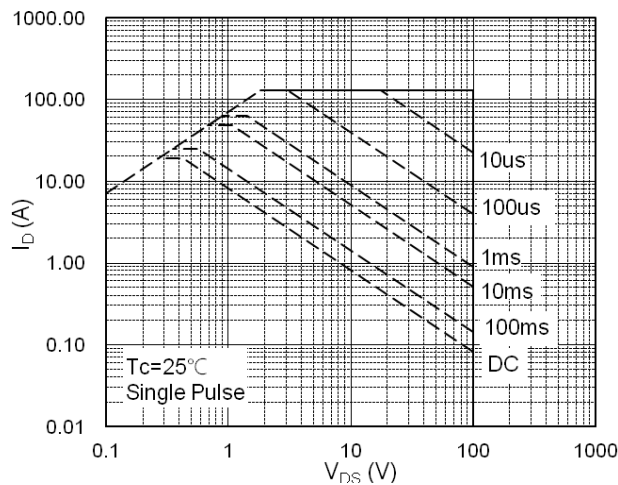

Fig.8 Safe Operating Area

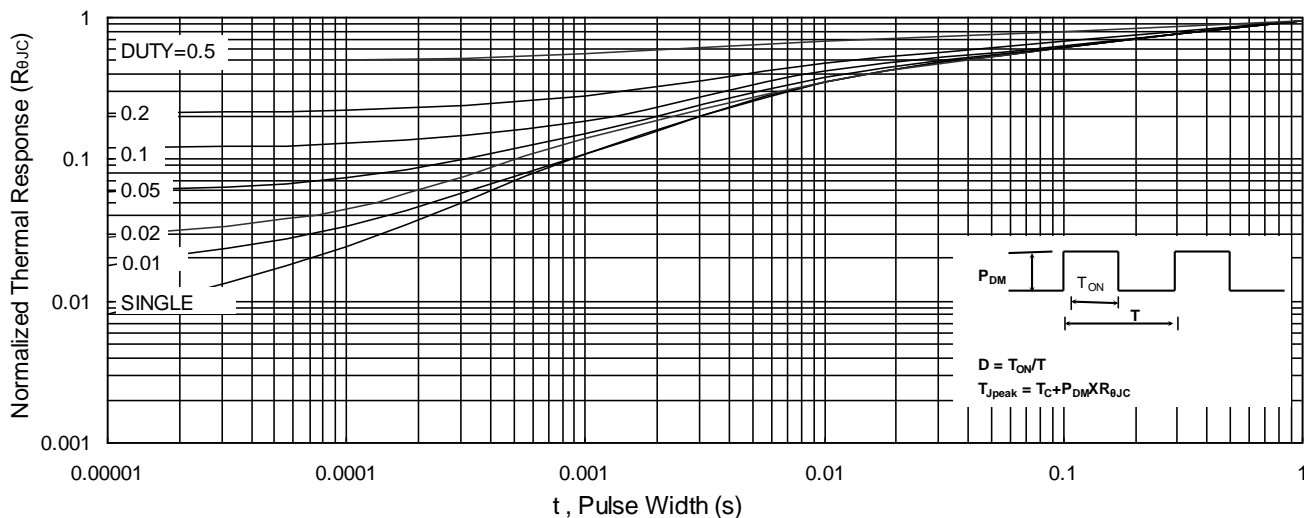

Fig.9 Normalized Maximum Transient Thermal Impedance

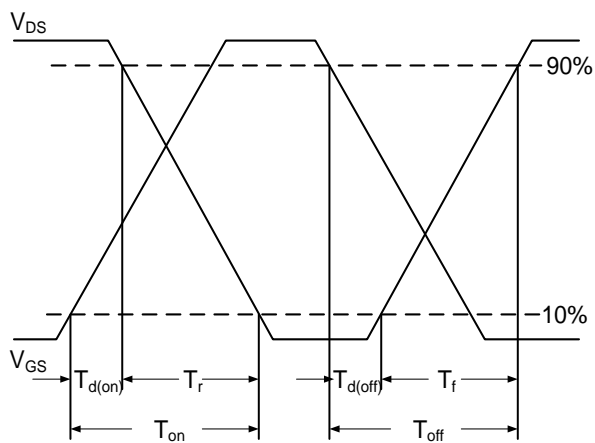

Fig.10 Switching Time Waveform

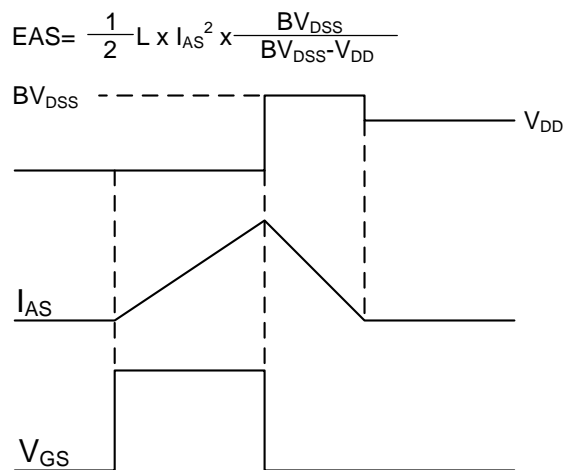
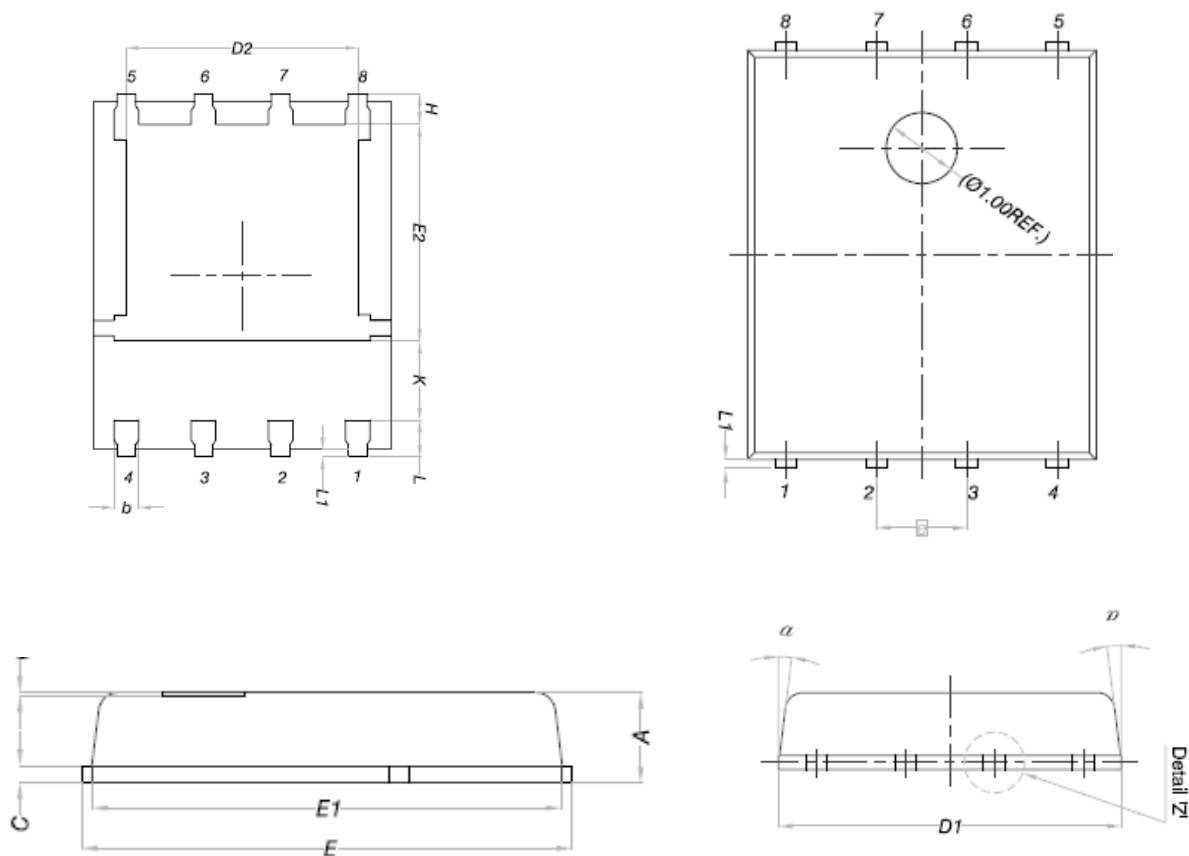

Fig.11 Unclamped Inductive Switching Waveform

DFN5x6

DIM.	MILLIMETERS			DIM.	MILLIMETERS		
	MIN.	NOM.	MAX.		MIN.	NOM.	MAX.
A	0.90	1.00	1.10	E	5.90	6.00	6.10
A1	0	-	0.05	E1	5.70	5.75	5.80
b	0.33	0.41	0.51	E2	3.38	3.58	3.78
C	0.20	0.25	0.30	e	1.27 BSC		
D1	4.80	4.90	5.00	H	0.41	0.51	0.61
D2	3.61	3.81	3.96	K	1.10	-	-
				L	0.51	0.61	0.71
				L1	0.06	0.13	0.20
				alpha	0°	-	12°

X-ON Electronics

Largest Supplier of Electrical and Electronic Components

Click to view similar products for [MOSFET](#) category:

Click to view products by [SLKORMICRO](#) manufacturer:

Other Similar products are found below :

[614233C](#) [648584F](#) [MCH3443-TL-E](#) [MCH6422-TL-E](#) [FDPF9N50NZ](#) [FW216A-TL-2W](#) [FW231A-TL-E](#) [APT5010JVR](#) [NTNS3A92PZT5G](#)
[IRF100S201](#) [JANTX2N5237](#) [2SK2464-TL-E](#) [2SK3818-DL-E](#) [FCA20N60_F109](#) [FDZ595PZ](#) [STD6600NT4G](#) [FSS804-TL-E](#) [2SJ277-DL-E](#)
[2SK1691-DL-E](#) [2SK2545\(Q,T\)](#) [D2294UK](#) [405094E](#) [423220D](#) [MCH6646-TL-E](#) [TPCC8103,L1Q\(CM](#) [367-8430-0972-503](#) [VN1206L](#)
[424134F](#) [026935X](#) [051075F](#) [SBVS138LT1G](#) [614234A](#) [715780A](#) [NTNS3166NZT5G](#) [751625C](#) [873612G](#) [IRF7380TRHR](#)
[IPS70R2K0CEAKMA1](#) [RJK60S3DPP-E0#T2](#) [RJK60S5DPK-M0#T0](#) [APT5010JVFR](#) [APT12031JFLL](#) [APT12040JVR](#) [DMN3404LQ-7](#)
[NTE6400](#) [JANTX2N6796U](#) [JANTX2N6784U](#) [JANTXV2N5416U4](#) [SQM110N05-06L-GE3](#) [SIHF35N60E-GE3](#)