

## Low Power Voltage Detector

### General Description

The SL70XXA series devices are a set of three terminal low power voltage detectors implemented in CMOS technology. Each voltage detector in the series detects a particular fixed voltage ranging from 2.2V to 7.0V. The voltage detectors consist of a high-precision and low power consumption standard voltage source as well as a comparator, hysteresis circuit, and an output driver. CMOS technology ensures low power consumption.

Although designed primarily as fixed voltage detectors, these devices can be used with external components to detect user specified threshold voltages.

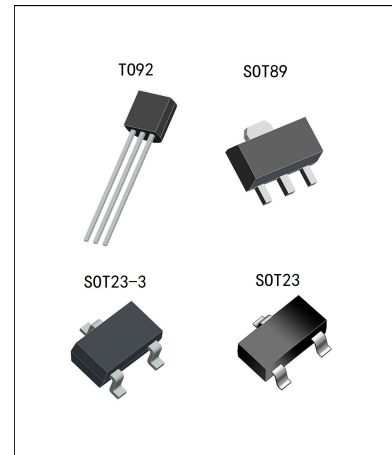

### Features

- Low power consumption
- Low temperature coefficient
- Built-in hysteresis characteristic
- High input voltage (up to 15V)
- Output voltage accuracy: tolerance  $\pm 1\%$  or  $\pm 2\%$
- TO92, SOT89, SOT23 and SOT23-3 package

### Applications

- Battery checkers
- Level selectors
- Power failure detectors
- Microcomputer reset
- Battery memory backup
- Non-volatile RAM signal storage protectors

## Order Information

Part No	Detectable Voltage	Hysteresis Width	Tolerance
SL7022A	2.2V	0.11V	±2%
SL7024A	2.4V	0.12V	±2%
SL7044A	4.4V	0.22V	±2%
SL7050A	5.0V	0.25V	±2%
SL7070A	7.0V	0.35V	±2%

Package	Manner of Packing	Devices per bag/reel
TO92	Bag	1000PCS/bag
SOT89	Reel	1000PCS/reel
SOT23-3	Reel	3000PCS/reel
SOT23	Reel	3000PCS/reel

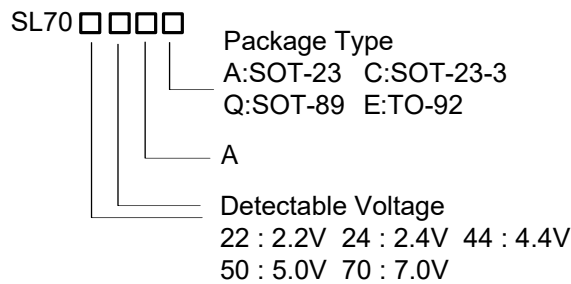

## Block Diagram and Pin Arrangement Diagram

(1) CMOS Output

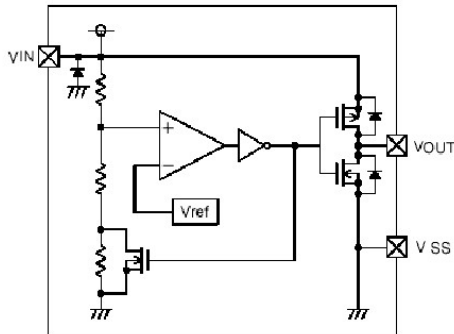

(2) N-ch Open Drain Output

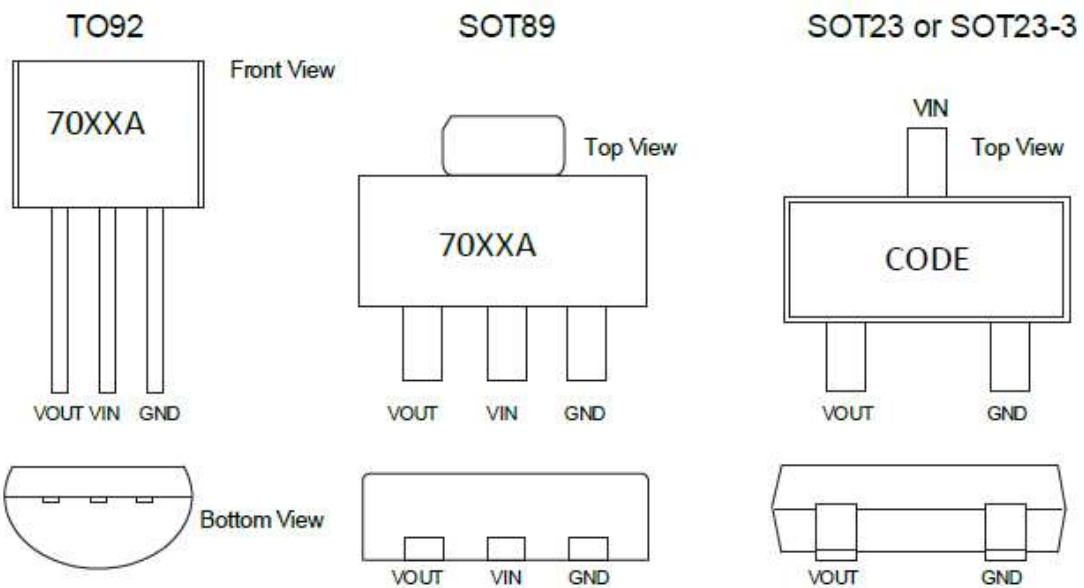
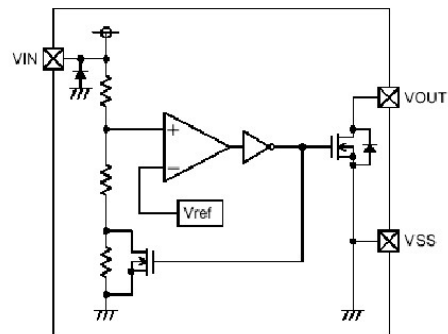

## Pin Assignment

Pin No.	Pin Name	Description
1	VOUT	Output.
2	VIN	Supply Voltage Input.
3	GND	Ground connection.

## Output Table & Curve

$V_{DD}$	$V_{DD} > V_{DET}(+)$	$V_{DD} \leq V_{DET}(-)$
$V_{OUT}$	Hi-Z	$V_{SS}$

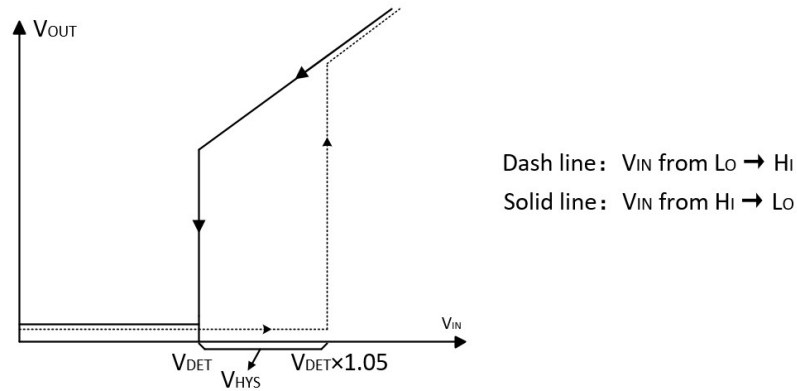

## Functional Description

The SL70XXA series devices are a set of three terminal low power voltage detectors implemented in CMOS technology. Each voltage detector in the series detects a particular fixed voltage ranging from 2.2V to 7.0V.

## Absolute Maximum Ratings

Parameter	Symbol	Value	Unit
Supply Voltage Input	$V_{IN}$	-0.3~16	V
Operating Temperature	$T_{amb}$	-40~85	$^{\circ}C$
Storage Temperature	$T_{stg}$	-50~125	$^{\circ}C$

Note: These are stress ratings only. Stresses exceeding the range specified under "Absolute Maximum Ratings" may cause substantial damage to the device. prolonged exposure to extreme conditions may affect device reliability.

## Thermal Information

Parameter	Symbol	Package	Max.	Unit
Thermal Resistance (Junction to Ambient) (Assume no ambient airflow, no heat sink)	$\theta_{JA}$	SOT23	500	$^{\circ}C/W$
		SOT89	200	$^{\circ}C/W$
		TO92	200	$^{\circ}C/W$
Power Dissipation	$P_D$	SOT23	0.20	W
		SOT89	0.50	W
		TO92	0.50	W

## Electrical Characteristics

SL7022A , Ta=25°C

Parameter	Symbol	Test Conditions		Min.	Typ.	Max.	Unit
		V <sub>DD</sub>	Conditions				
Detection Voltage	V <sub>DET</sub>	-	-	2.156	2.200	2.244	V
Hysteresis Width	V <sub>HYS</sub>	-	-	0.02* V <sub>DET</sub>	0.05* V <sub>DET</sub>	0.10* V <sub>DET</sub>	V
Operating Current	I <sub>DD</sub>	8V	No Load	-	2	3	μA
Operating Voltage	V <sub>DD</sub>	-	-	1.5	-	16	V
Output Sink Current	I <sub>OL</sub>	2V	V <sub>OUT</sub> =0.2V	0.5	1	-	mA
Temperature Coefficient	$\frac{\Delta V_{DET}}{\Delta T_a}$	-	0°C <Ta<70°C	-	±0.9	-	mV/ °C

SL7024A , Ta=25°C

Parameter	Symbol	Test Conditions		Min.	Typ.	Max.	Unit
		V <sub>DD</sub>	Conditions				
Detection Voltage	V <sub>DET</sub>	-	-	2.352	2.400	2.448	V
Hysteresis Width	V <sub>HYS</sub>	-	-	0.02* V <sub>DET</sub>	0.05* V <sub>DET</sub>	0.10* V <sub>DET</sub>	V
Operating Current	I <sub>DD</sub>	8V	No Load	-	2	3	μA
Operating Voltage	V <sub>DD</sub>	-	-	1.5	-	16	V
Output Sink Current	I <sub>OL</sub>	2V	V <sub>OUT</sub> =0.2V	0.5	1	-	mA
Temperature Coefficient	$\frac{\Delta V_{DET}}{\Delta T_a}$	-	0°C <Ta<70°C	-	±0.9	-	mV/ °C

**SL7044A , Ta=25°C**

Parameter	Symbol	Test Conditions		Min.	Typ.	Max.	Unit
		V <sub>DD</sub>	Conditions				
Detection Voltage	V <sub>DET</sub>	-	-	4.312	4.400	4.488	V
Hysteresis Width	V <sub>HYS</sub>	-	-	0.02* V <sub>DET</sub>	0.05* V <sub>DET</sub>	0.10* V <sub>DET</sub>	V
Operating Current	I <sub>DD</sub>	8V	No Load	-	2	3	μA
Operating Voltage	V <sub>DD</sub>	-	-	1.5	-	16	V
Output Sink Current	I <sub>OL</sub>	2V	V <sub>OUT</sub> =0.2V	3	6	-	mA
Temperature Coefficient	$\frac{\Delta V_{DET}}{\Delta T_a}$	-	0°C <T <sub>a</sub> <70°C	-	±0.9	-	mV/ °C

**SL7050A , Ta=25°C**

Parameter	Symbol	Test Conditions		Min.	Typ.	Max.	Unit
		V <sub>DD</sub>	Conditions				
Detection Voltage	V <sub>DET</sub>	-	-	4.900	5.000	5.100	V
Hysteresis Width	V <sub>HYS</sub>	-	-	0.02* V <sub>DET</sub>	0.05* V <sub>DET</sub>	0.10* V <sub>DET</sub>	V
Operating Current	I <sub>DD</sub>	8V	No Load	-	2	3	μA
Operating Voltage	V <sub>DD</sub>	-	-	1.5	-	16	V
Output Sink Current	I <sub>OL</sub>	2V	V <sub>OUT</sub> =0.2V	3	6	-	mA
Temperature Coefficient	$\frac{\Delta V_{DET}}{\Delta T_a}$	-	0°C <T <sub>a</sub> <70°C	-	±0.9	-	mV/ °C

**SL7070A, Ta=25°C**

Parameter	Symbol	Test Conditions		Min.	Typ.	Max.	Unit
		V <sub>DD</sub>	Conditions				
Detection Voltage	V <sub>DET</sub>	-	-	6.860	7.000	7.140	V
Hysteresis Width	V <sub>HYS</sub>	-	-	0.02* V <sub>DET</sub>	0.05* V <sub>DET</sub>	0.10* V <sub>DET</sub>	V
Operating Current	I <sub>DD</sub>	8V	No Load	-	2	3	μA
Operating Voltage	V <sub>DD</sub>	-	-	1.5	-	16	V
Output Sink Current	I <sub>OL</sub>	2V	V <sub>OUT</sub> =0.2V	3	6	-	mA
Temperature Coefficient	$\frac{\Delta V_{DET}}{\Delta T_a}$	-	0°C <Ta<70°C	-	±0.9	-	mV/ °C

## Application Circuits

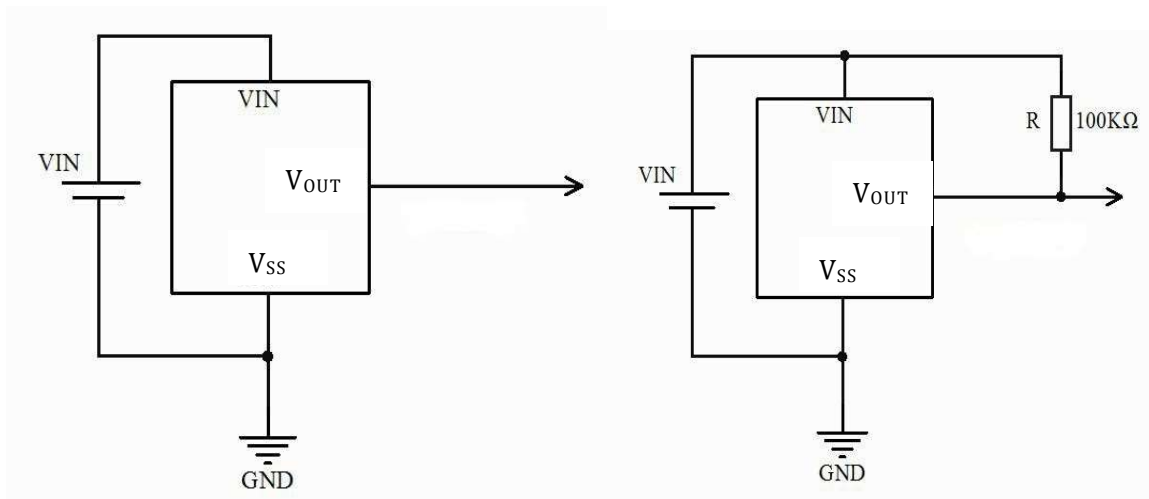

CMOS Output

N-ch Open Drain Output

## Microcomputer Reset Circuit

Normally a reset circuit is required to protect the microcomputer system from malfunctions due to power line interruptions. The following examples show how different output configurations perform a reset function in various systems.

NMOS open drain output application for separate power supply:

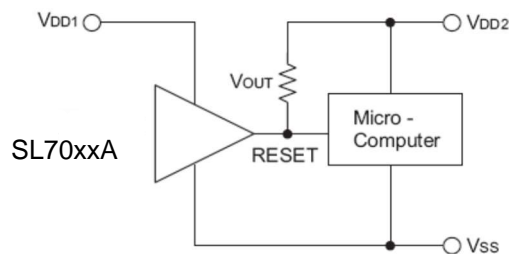

NMOS open drain output application with R-C delay:

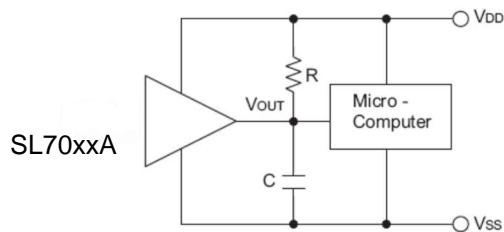



## Power-on Reset Circuit

With several external components, the NMOS open drain type of the SL70XXA series can be used to perform a power-on reset function as shown:

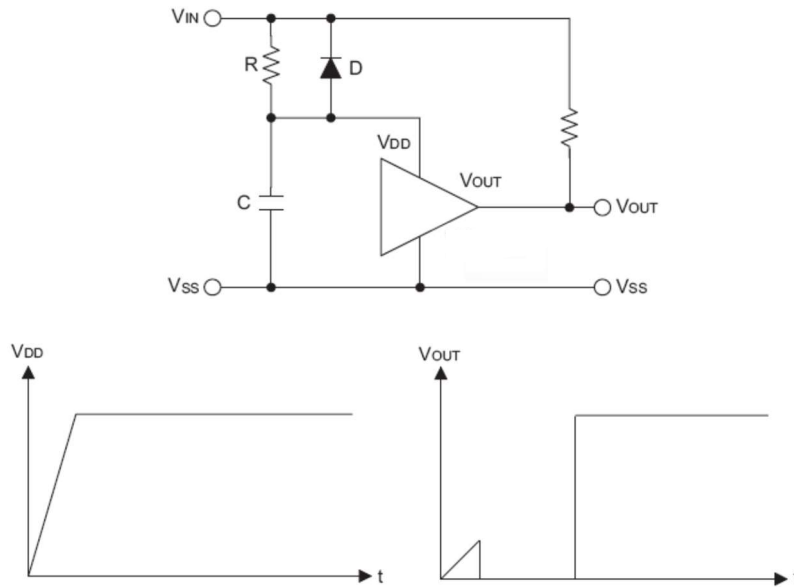

## 5V Power Line Monitoring Circuit

Generally, a minimum operating voltage of 4.5V is guaranteed in a 5V power line system.

5V power line monitor with power-on reset:

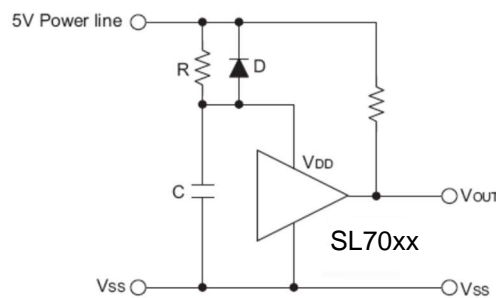

With 5V voltage regulator:

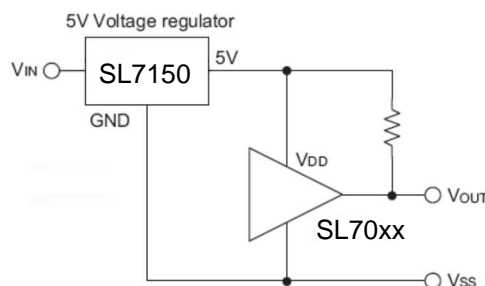

## Change of Detectable Voltage

If the required voltage is not found in the standard product selection table, it is possible to change it by using external resistance dividers or diodes.

Varying the detectable voltage with a resistance divider:

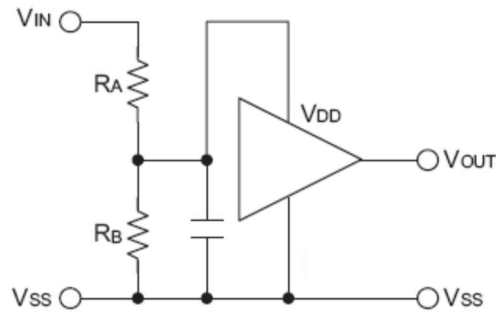

$$\text{Detectable voltage} = \frac{R_A + R_B}{R_B} \times V_{\text{DET}}$$

$$\text{Hysteresis width} = \frac{R_A + R_B}{R_B} \times V_{\text{HYS}}$$

Varying the detectable voltage with a diode:

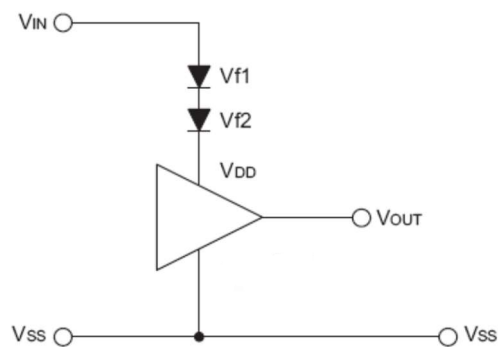

$$\text{Detectable Voltage} = V_{f1} + V_{f2} + V_{\text{DET}}$$

## Malfunction Analysis

The following circuit demonstrates the way a circuit analyzes malfunctions by monitoring the variation or spike noise of power supply voltage.

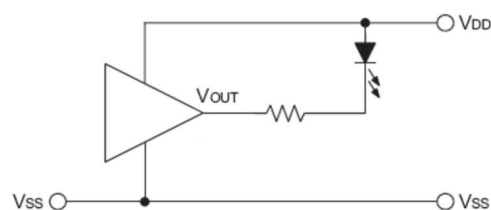

## Charge Monitoring Circuit

The following circuit shows a charged monitor for protection against battery deterioration by overcharging. When the voltage of the battery is higher than the set detectable voltage, the transistor turns onto bypass the charge current, protecting the battery from overcharging.

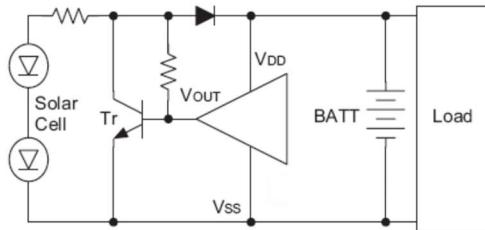

## Level Selector

The following diagram illustrates a logic level selector.

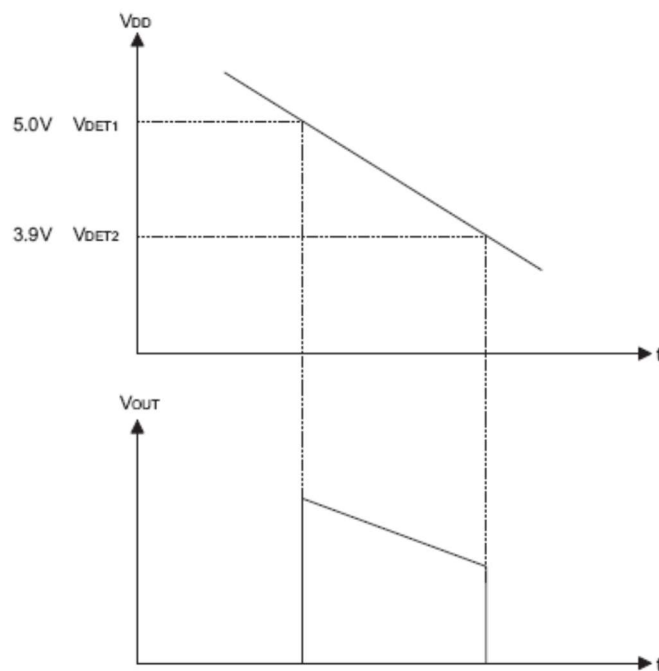
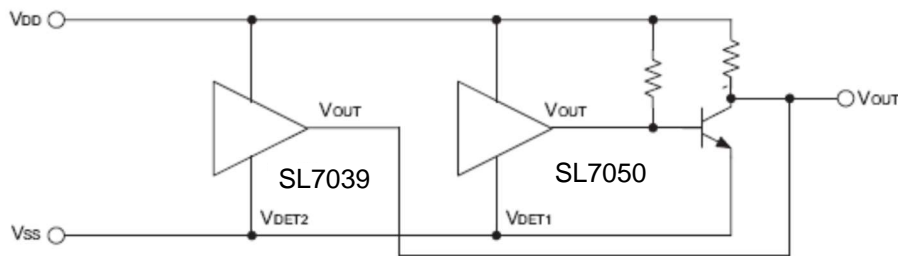

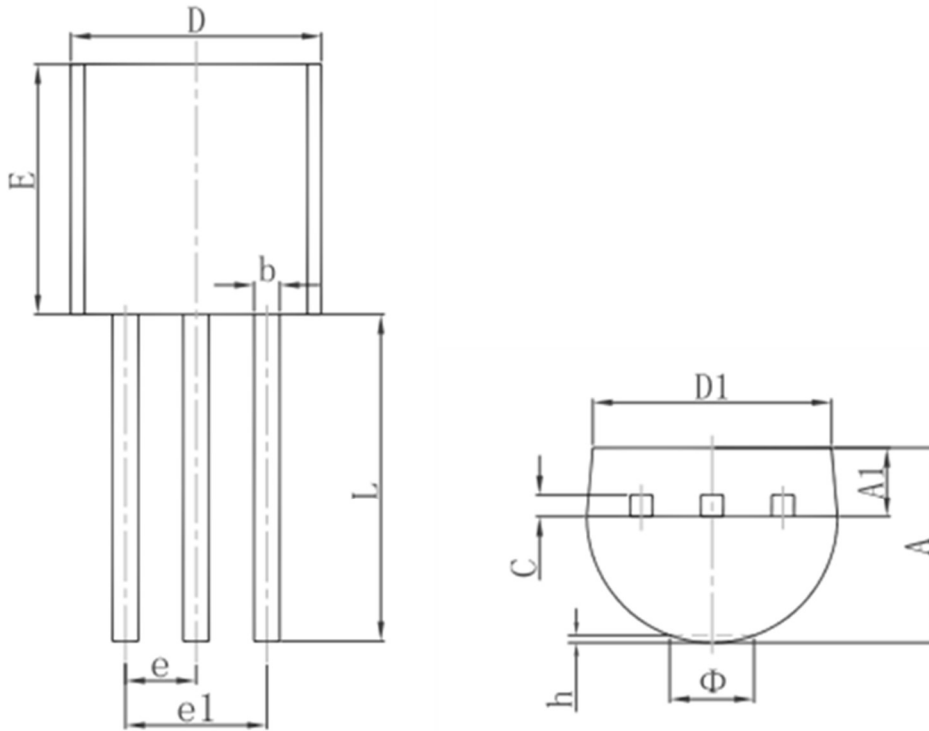
**Package Information (T092)**

Symbol	Dimensions In Millimeters		Dimensions In Inches	
	Min.	Max.	Min.	Max.
<b>A</b>	3.300	3.700	0.130	0.146
<b>A1</b>	1.100	1.400	0.043	0.055
<b>b</b>	0.380	0.550	0.015	0.022
<b>c</b>	0.360	0.510	0.014	0.020
<b>D</b>	4.300	4.700	0.169	0.185
<b>D1</b>	3.430		0.135	
<b>E</b>	4.300	4.700	0.169	0.185
<b>e</b>	1.270TYP.		0.050TYP.	
<b>e1</b>	2.440	2.640	0.096	0.104
<b>L</b>	14.100	14.500	0.555	0.571
<b>Φ</b>		1.600		0.063
<b>h</b>	0.000	0.380	0.000	0.015

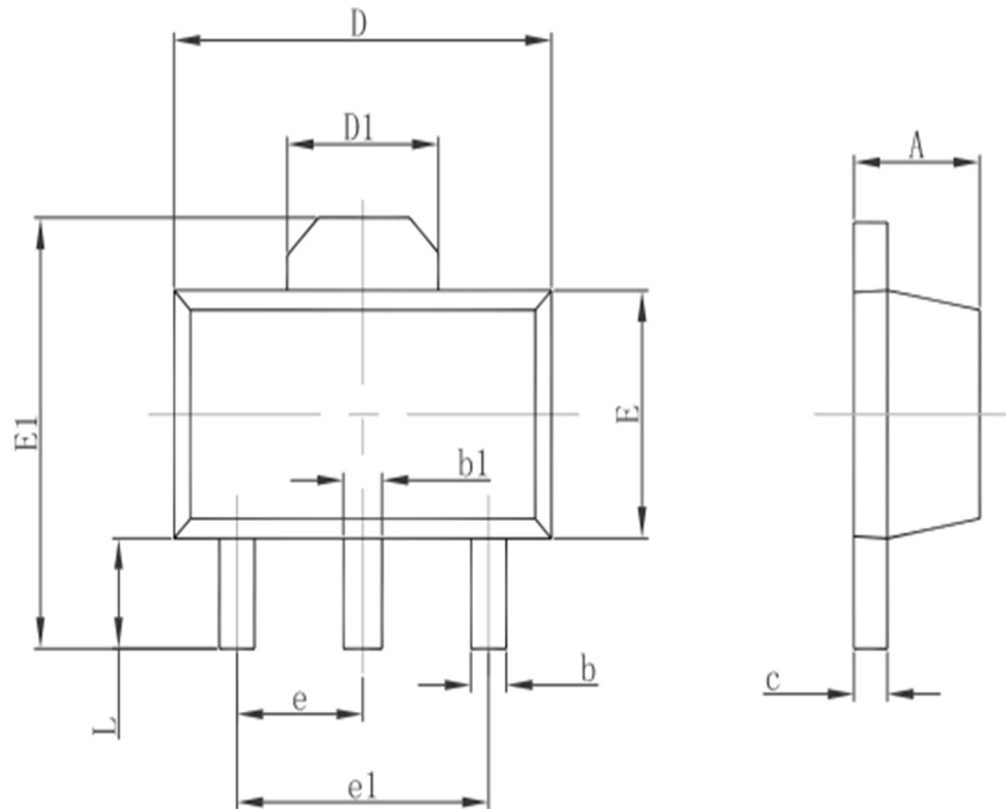
**Package Information (SOT89)**

Symbol	Dimensions In Millimeters		Dimensions In Inches	
	Min.	Max.	Min.	Max.
<b>A</b>	1.400	1.600	0.055	0.063
<b>b</b>	0.320	0.520	0.013	0.020
<b>b1</b>	0.400	0.580	0.016	0.023
<b>c</b>	0.350	0.440	0.014	0.017
<b>D</b>	4.400	4.600	0.173	0.181
<b>D1</b>	1.550REF.		0.061REF.	
<b>E</b>	2.300	2.600	0.091	0.102
<b>E1</b>	3.940	4.250	0.155	0.167
<b>e</b>	1.500TYP.		0.060TYP.	
<b>e1</b>	3.000TYP.		0.118TYP.	
<b>L</b>	0.900	1.200	0.035	0.047

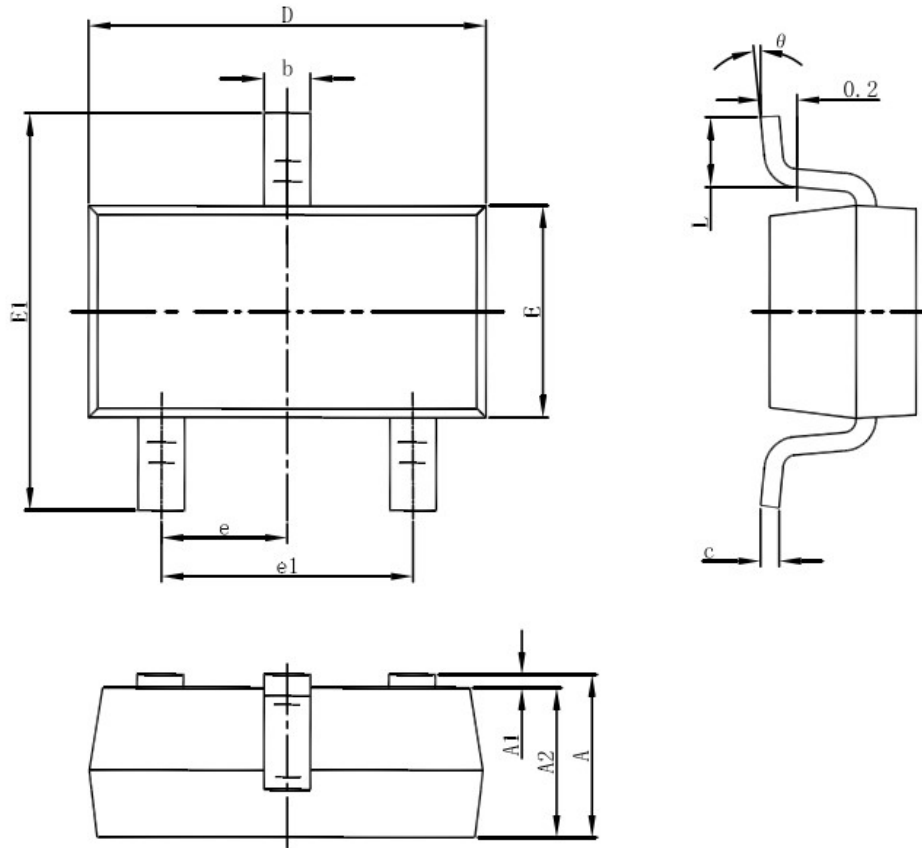
**Package Information (SOT23-3)**

Symbol	Dimensions In Millimeters		Dimensions In Inches	
	Min.	Max.	Min.	Max.
<b>A</b>	1.050	1.250	0.041	0.049
<b>A1</b>	0.000	0.100	0.000	0.004
<b>A2</b>	1.050	1.150	0.041	0.045
<b>b</b>	0.300	0.500	0.012	0.020
<b>c</b>	0.100	0.200	0.004	0.008
<b>D</b>	2.820	3.020	0.111	0.119
<b>E</b>	1.500	1.700	0.059	0.067
<b>E1</b>	2.650	2.950	0.104	0.116
<b>e</b>	0.950(BSC)		0.037(BSC)	
<b>e1</b>	1.800	2.000	0.071	0.079
<b>L</b>	0.300	0.600	0.012	0.024
<b><math>\theta</math></b>	0°	8°	0°	8°

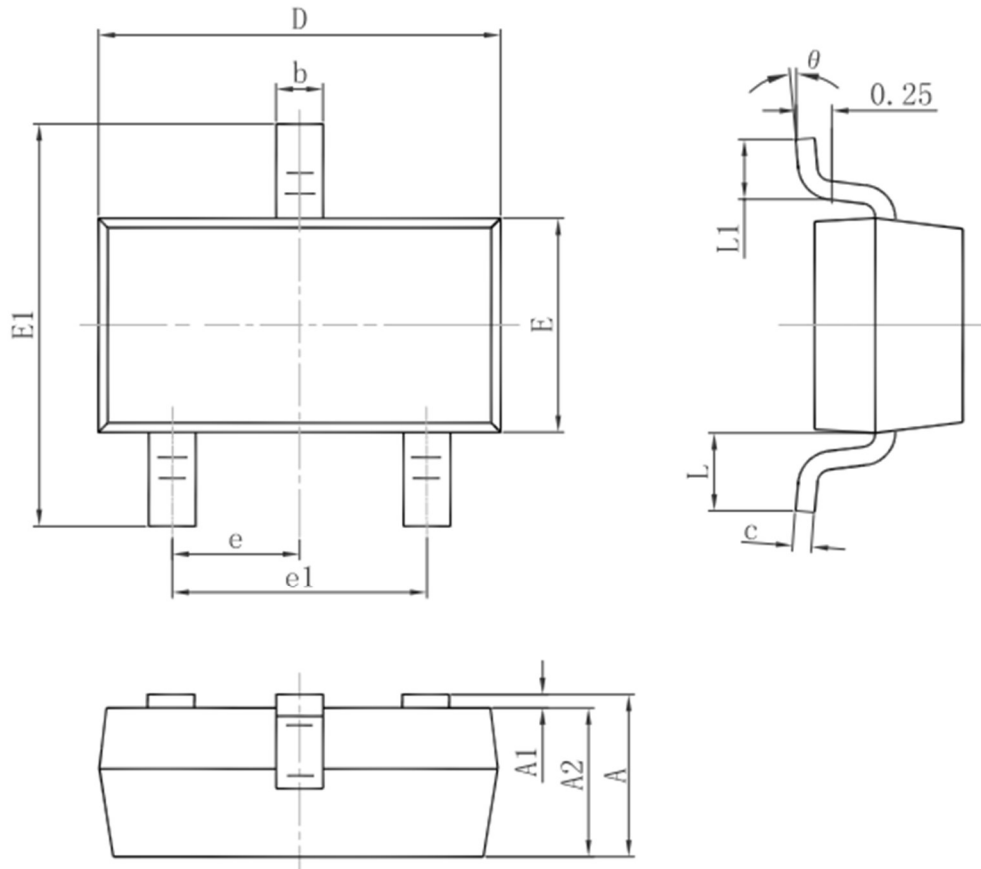
**Package Information (SOT23)**

Symbol	Dimensions In Millimeters		Dimensions In Inches	
	Min.	Max.	Min.	Max.
<b>A</b>	0.900	1.150	0.035	0.045
<b>A1</b>	0.000	0.100	0.000	0.004
<b>A2</b>	0.900	1.050	0.035	0.041
<b>b</b>	0.300	0.500	0.012	0.020
<b>c</b>	0.080	0.150	0.003	0.006
<b>D</b>	2.800	3.000	0.110	0.118
<b>E</b>	1.200	1.400	0.047	0.055
<b>E1</b>	2.250	2.550	0.089	0.100
<b>e</b>	0.950TYP.		0.037TYP.	
<b>e1</b>	1.800	2.000	0.071	0.079
<b>L</b>	0.550REF.		0.022REF.	
<b>L1</b>	0.300	0.500	0.012	0.020
<b>θ</b>	0°	8°	0°	8°

## X-ON Electronics

Largest Supplier of Electrical and Electronic Components

*Click to view similar products for [Supervisory Circuits](#) category:*

*Click to view products by [SLKORMICRO](#) manufacturer:*

Other Similar products are found below :

[CAT1161LI-25-G](#) [CAT853STBI-T3](#) [DS1232L](#) [NCV302HSN45T1G](#) [STM6710FWB7F](#) [S-1000N28-I4T1U](#) [S-1000N23-I4T1U](#) [S-1000N19-I4T1U](#) [PT7M6133NLTA3EX](#) [PT7M6127NLTA3EX](#) [ISL88011IH526Z-TK](#) [ISL88013IH529Z-TK](#) [ISL88705IP846Z](#) [ISL88706IP831Z](#) [ISL88708IB844Z](#) [ISL88708IP831Z](#) [TCM811MERCCTR](#) [X40420S14-A](#) [X40421S14-C](#) [X40430S14-A](#) [X40430S14I-A](#) [X40430S14I-B](#) [X40431S14-A](#) [X40431S14-B](#) [X40431S14-C](#) [X40431S14I-A](#) [X40431S14I-B](#) [X40431S14I-C](#) [X4043P-2.7](#) [X4043PI-2.7](#) [X4043S8-2.7T1](#) [X4043S8IZ-2.7](#) [X4043S8IZT1](#) [X4043S8T1](#) [X4045P](#) [X4045PI](#) [X4045PI-2.7](#) [X4045S8-2.7T1](#) [X4045S8IZ](#) [X4045S8T1](#) [X4163P](#) [X4163P-2.7](#) [X4163PI](#) [X4163PI-2.7](#) [X4163S8](#) [X4165P](#) [X4165P-2.7](#) [X4165PI](#) [X4165PI-2.7](#) [X4165S8I-2.7](#)