

Low Dropout Regulators

Description

The SL9400 is a high accuracy, low noise, high speed CMOS Linear regulator with low power consumption and low dropout voltage, which provide large output currents even when the difference of the input-output voltage is small. The devices offer a new level of cost effective performance in cellular phones, laptop and notebook computers, and other portable devices.

The current limiter's fold-back circuit also operates as a short circuit protection and an output current limiter at the output pin.

Standard products are Pb-free and Halogen-free.

Features

- Low Quiescent Current: 0.5 μ A(Typ.)
- Wide Input Voltage Range: 1.5V~8V
- Output Voltage Range: 1.2V~5V(customized by every 0.1V step)
- Maximum Output Current: 400mA @ $V_{OUT}=3.3V$
- Low Dropout : 180mV @ $I_{OUT}=100mA$
- Low Output Voltage Accuracy: $\pm 2\%$
- Shut-down Current: <1 μ A
- Short Circuit Protection
- Current Limiting Protection
- Available Packages: SOT-89, SOT-23-3, SOT-23-5 and DFN1x1-4L Packages

Applications

- Radio Control Systems
- Cellphones, Radiophone, Digital Cameras
- Bluetooth, Wireless Handsets

Typical Application Circuit

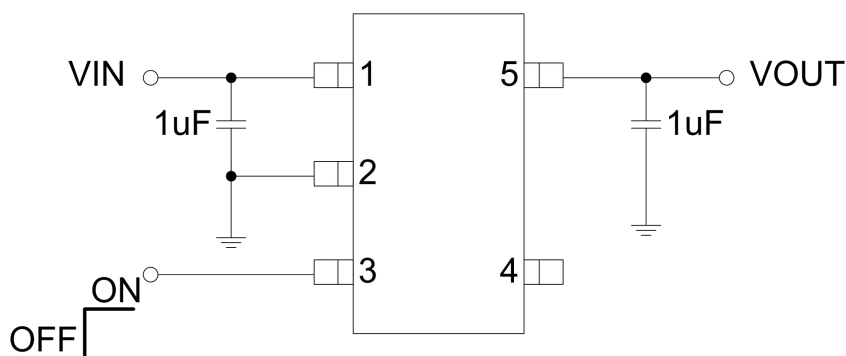

Pin Distribution

SOT-89

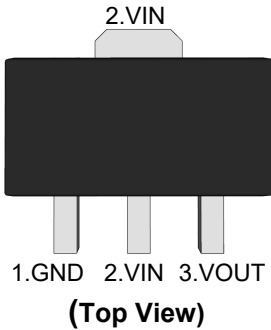

SOT-23-3

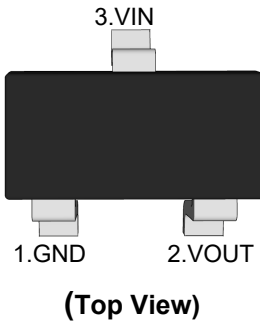

SOT-23-5

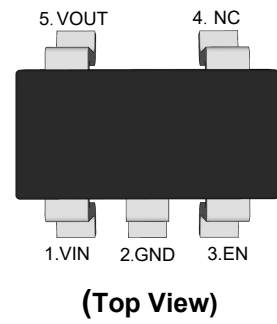

DFN1x1-4L

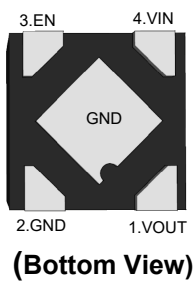

Functional Pin Description

Pin Name	Pin Function
VIN	Power Input Voltage
GND	Ground
EN	Chip Enable (Active High). Note that this pin is high impedance
NC	NO Connected
VOUT	Output Voltage

Ordering Information

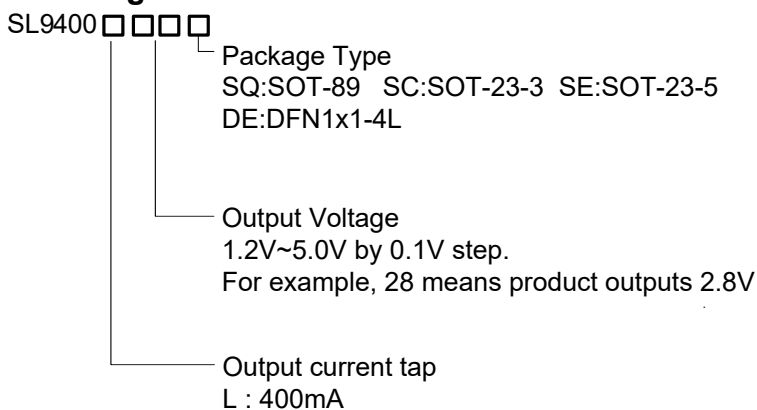

Ordering Information Continue

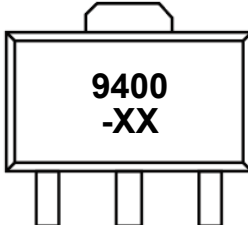
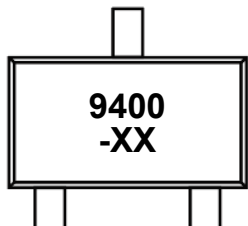
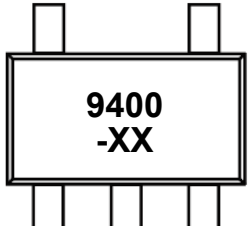
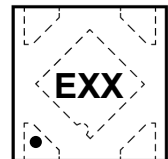
Orderable Device	Package	Reel (inch)	Package Qty (PCS)	Eco Plan ^{Note1}	MSL Level	Marking Code
SL9400LXXSQ ^{Note2}	SOT-89	7/13	1000/3000	RoHS & Green	MSL1	 <p>9400 -XX</p> <p>XX:Output Voltage e.g. 3.0:3.0V</p>
SL9400LXXSC ^{Note2}	SOT-23-3	7	3000	RoHS & Green	MSL3	 <p>9400 -XX</p> <p>XX:Output Voltage e.g. 3.0:3.0V</p>
SL9400LXXSE ^{Note2}	SOT-23-5	7	3000	RoHS & Green	MSL3	 <p>9400 -XX</p> <p>XX:Output Voltage e.g. 3.0:3.0V</p>
SL9400LXXDE ^{Note2}	DFN1x1-4L	7	1000	RoHS & Green	MSL1	 <p>EXX</p> <p>E:Product Code e.g. E: SL9400 Series XX:Output Voltage e.g. 30:30V</p>

Note:

1. RoHS: SL defines "RoHS" to mean semiconductor products that are compliant with the current EU RoHS requirements for all 10 RoHS substances, including the requirement that RoHS substance do not exceed 0.1% by weight in homogeneous materials.
Green: SL defines "Green" to mean Halogen-Free and Antimony-Free.
2. XX indicates 1.2V~5.0V by 0.1V step. For example, 28 means product outputs 2.8V

Function Block Diagram

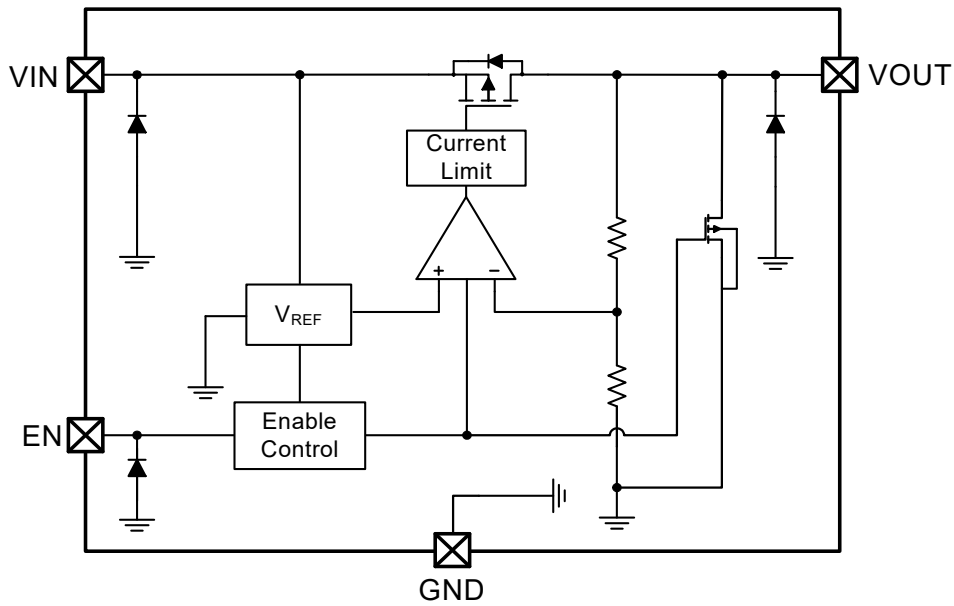

Absolute Maximum Ratings ^{Note3}

Ratings at 25°C ambient temperature unless otherwise specified.

Parameter		Value	Unit
Input Voltage	V_{IN}	-0.3 ~ +9	V
Maximum Load Current		450	mA
Power Dissipation	SOT-89	600	mW
	SOT-23-3	400	mW
	SOT-23-5	400	mW
	DFN1x1-4L	400	mW
Thermal Resistance, Junction-to-Ambient	SOT-89	250	°C/W
	SOT-23-3	400	°C/W
	SOT-23-5	400	°C/W
	DFN1x1-4L	400	°C/W
Operating Ambient Temperature		-40 ~ +85	°C
Junction Temperature		-40 ~ +125	°C
Storage temperature range		-55 ~ +150	°C
Lead Temperature		260°C, 10S	--

Note3: Exceed these limits to damage to the device. Exposure to absolute maximum rating conditions may affect.

Electrical Characteristics

($V_{OUT}=3.3V$, $C_{IN}=1\mu F$, $C_{OUT}=1\mu F$, $T_A=25^\circ C$, unless otherwise noted.)

Parameter		Symbol	Test Conditions	Min.	Typ.	Max.	Unit
Input Voltage		V_{IN}		1.5	--	8	V
Output Voltage Accuracy		ΔV_{OUT}	$I_{OUT}=1mA$	-2	--	+2	%
Quiescent Current		I_Q	$V_{OUT}=3.3V, I_{OUT}=0$	--	0.5	--	μA
Shut-down Current		I_{SHDN}	$V_{EN}=0V$	--	--	1	μA
Dropout Voltage		V_{DROP}	$V_{OUT}=3.3V, I_{OUT}=100mA$	--	180	--	mV
			$V_{OUT}=3.3V, I_{OUT}=200mA$	--	400	--	
Line Regulation		ΔV_{LINE}	$V_{IN}=2.7V\sim 5.5V, I_{OUT}=1mA$	--	0.01	0.15	%
Load Regulation		ΔV_{LOAD}	$1mA < I_{OUT} < 300mA, V_{OUT}=3.3V$	--	200	--	mV
Current Limit		I_{LIM}	$V_{IN}=V_{EN}=4.5V$	--	400	--	mA
Short Current		I_{SHORT}	$V_{EN}=V_{IN}$, V_{OUT} Short to GND with 1Ω	--	35	--	mA
EN Input Current		I_{EN}	$V_{EN}=0\sim 5.5V$	--	--	1	μA
EN Input Threshold	Logic Low	V_{IL}	$V_{IN}=5.5V, V_{OUT}=0V$	--	--	0.4	V
	Logic High	V_{IH}	$V_{IN}=5.5V, I_{OUT}=1mA$	1.2	--	V_{IN}	
Power Supply Rejection Rate		PSRR	$V_{IN}=5V_{DC}+0.5V_{P-P}$ $f=1KHz, I_{OUT}=10mA$	--	60	--	dB

Typical Electrical Curves

($V_{IN}=4.5V, V_{OUT}=3.3V, C_{IN}=1\mu F, C_{OUT}=1\mu F, T_A=25^\circ C$, unless otherwise noted, Package:SOT-23-5)

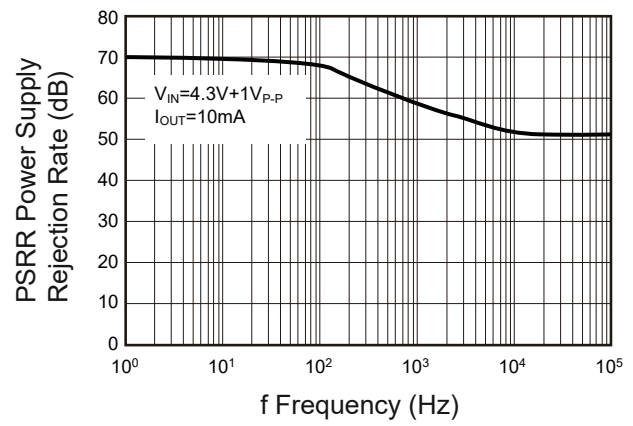
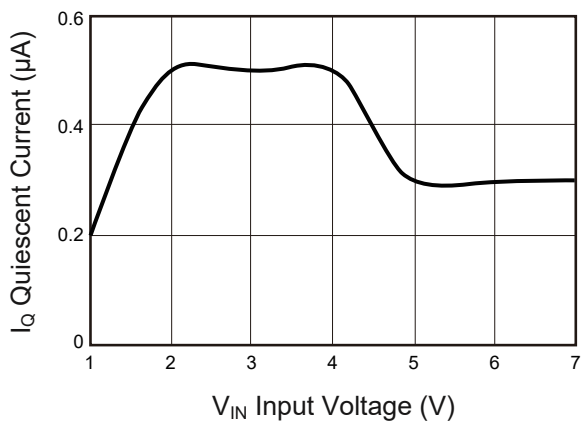
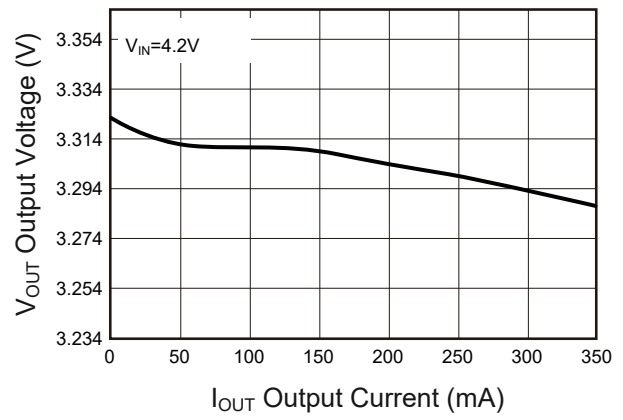
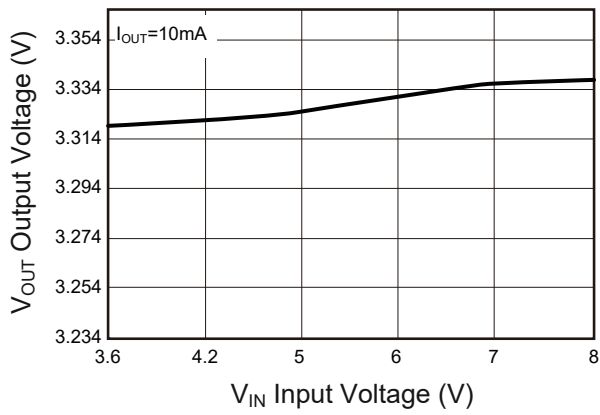

Power ON / OFF

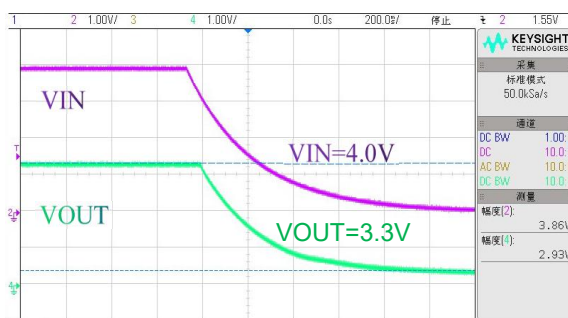
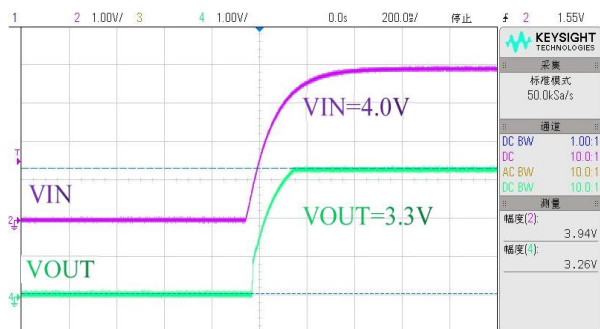

EN ON/OFF

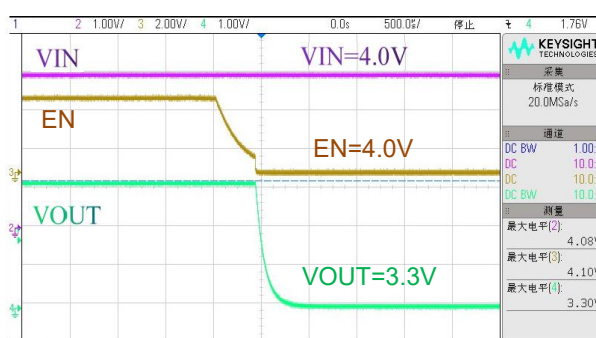
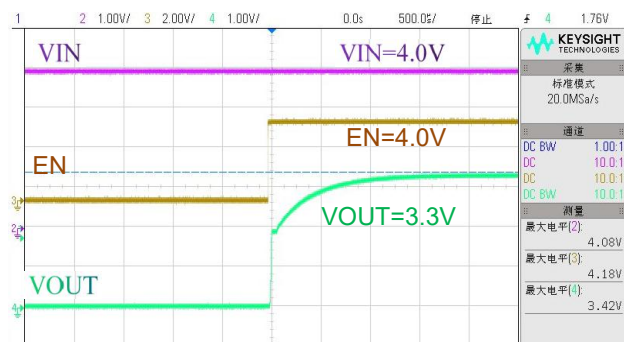

Line Transient

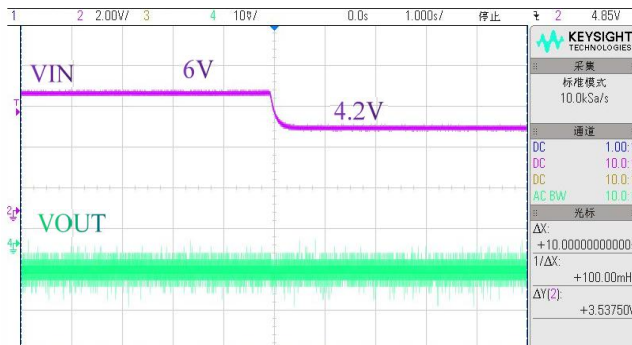
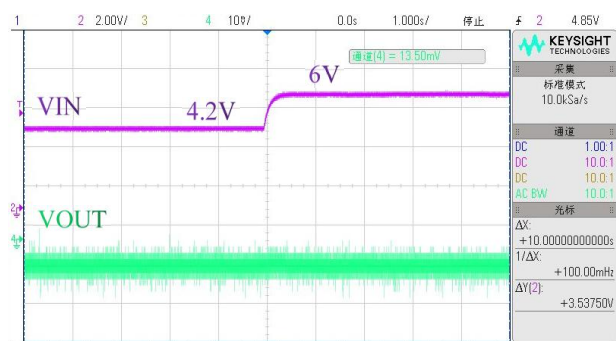

Load Transient

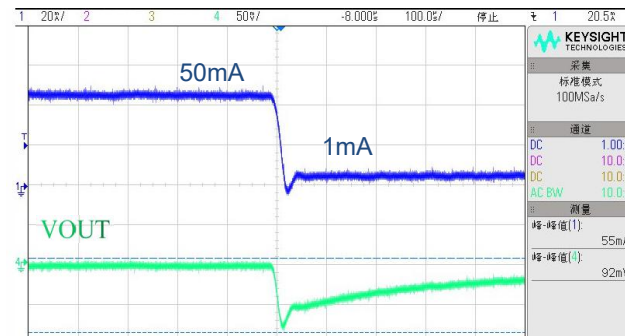
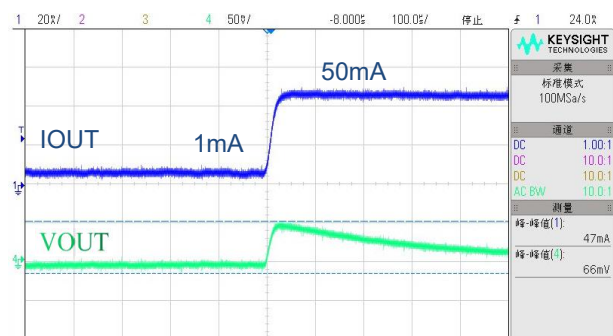

Package Outline

SOT-89

Dimensions in mm

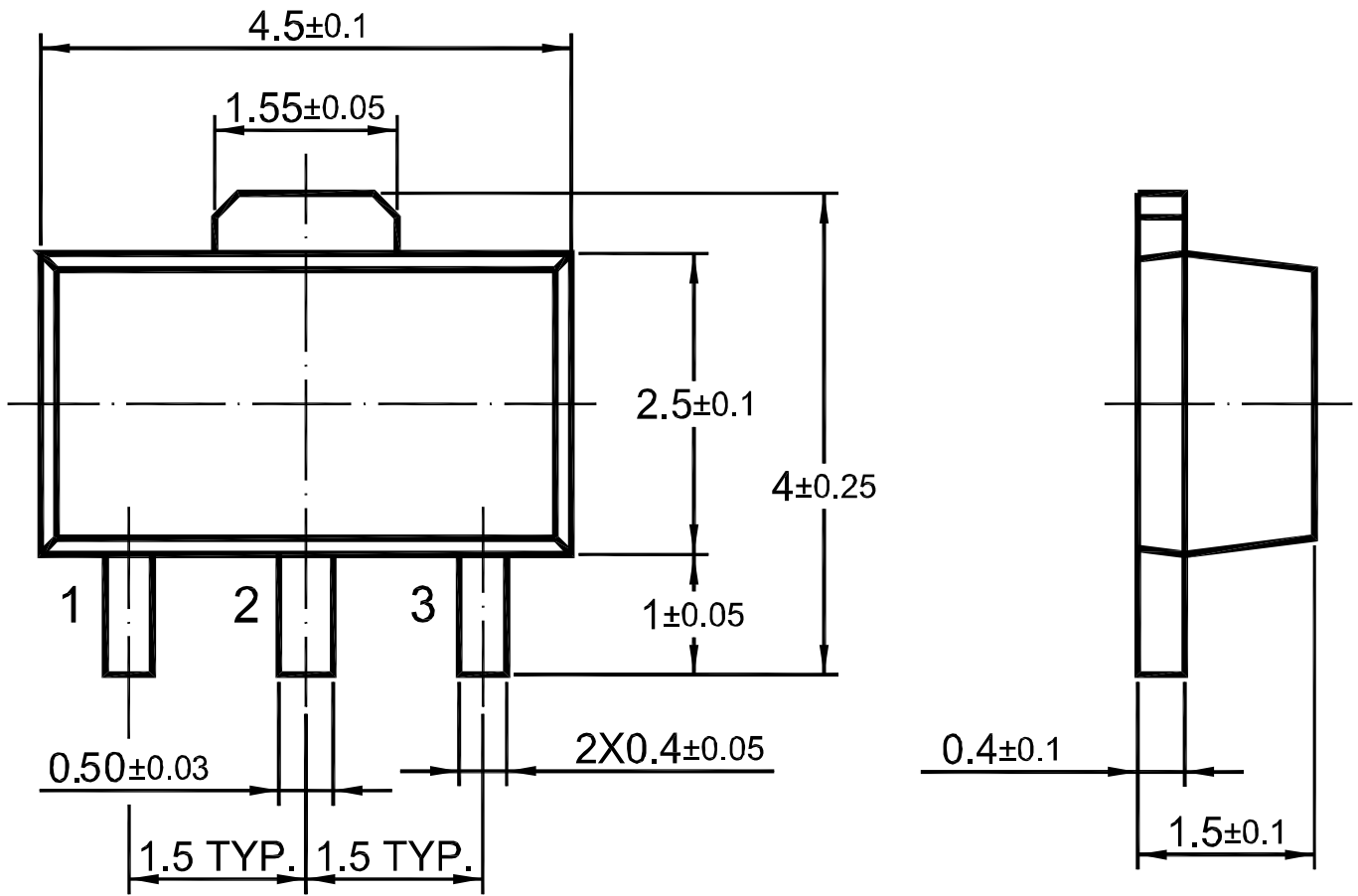

Package Outline

SOT-23-3

Dimensions in mm

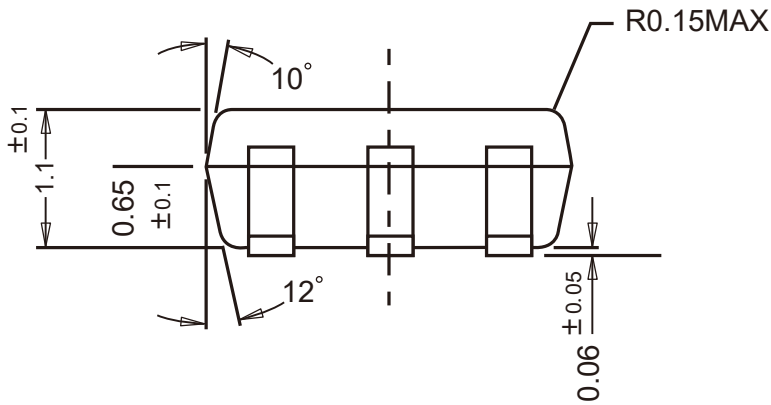
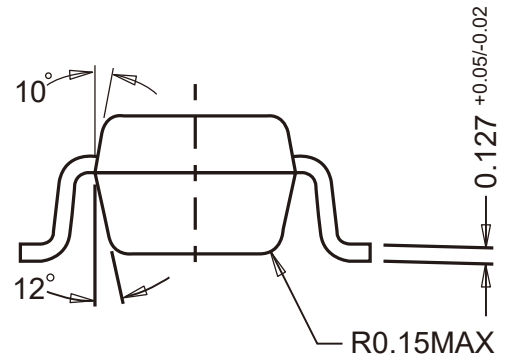
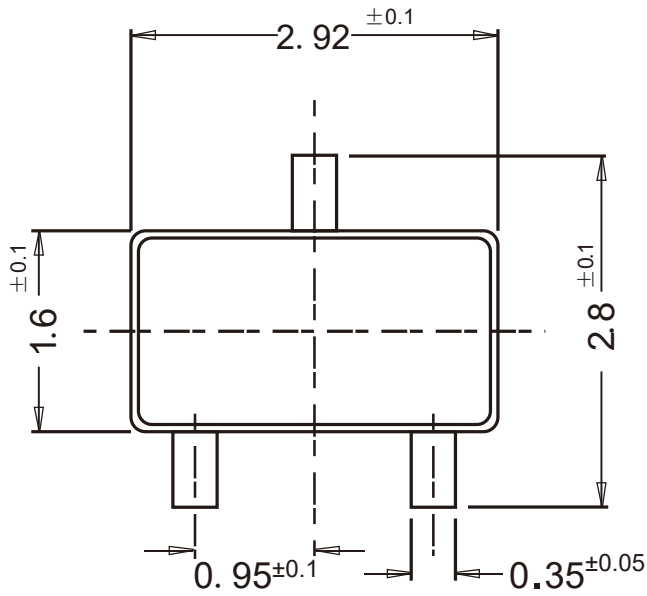

Package Outline

SOT-23-5

Dimensions in mm

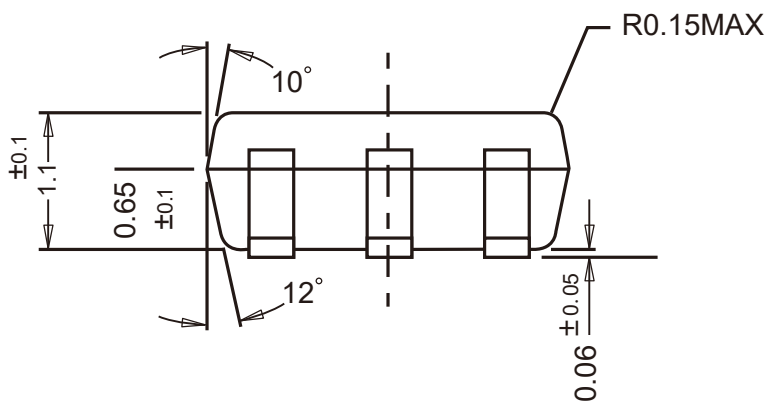
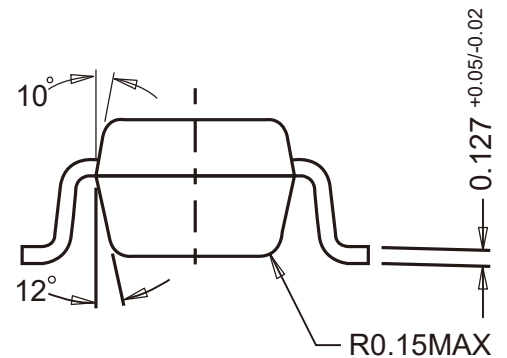
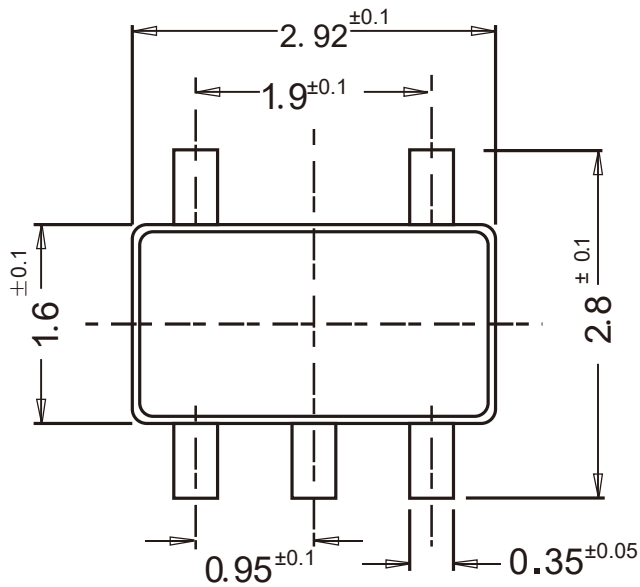

Package Outline

DFN1x1-4L

Dimensions in mm

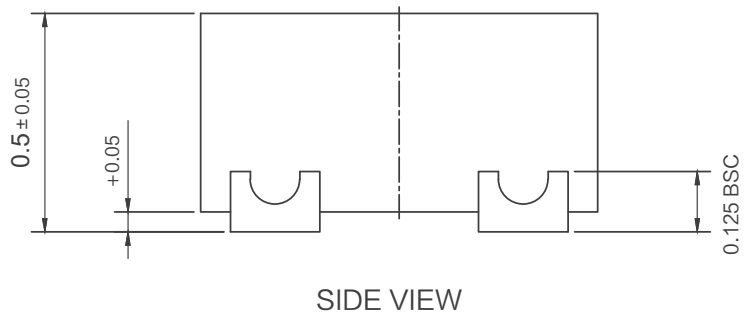
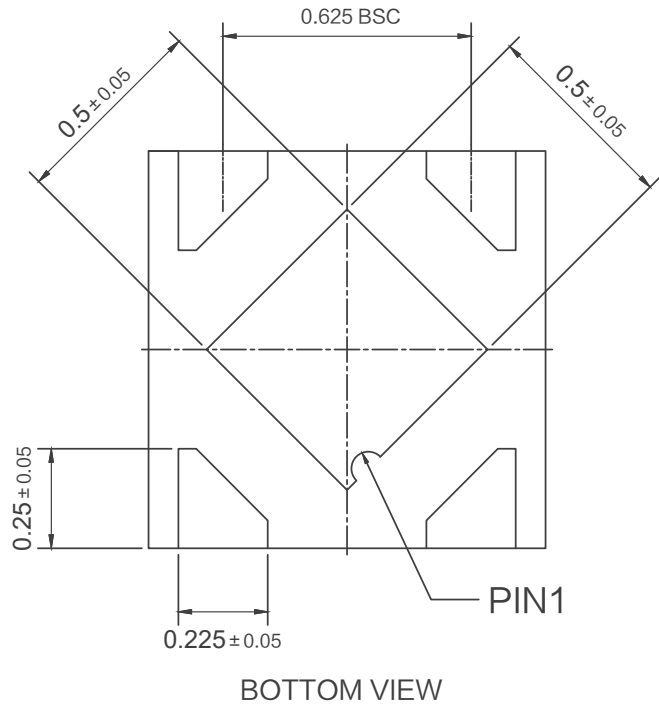
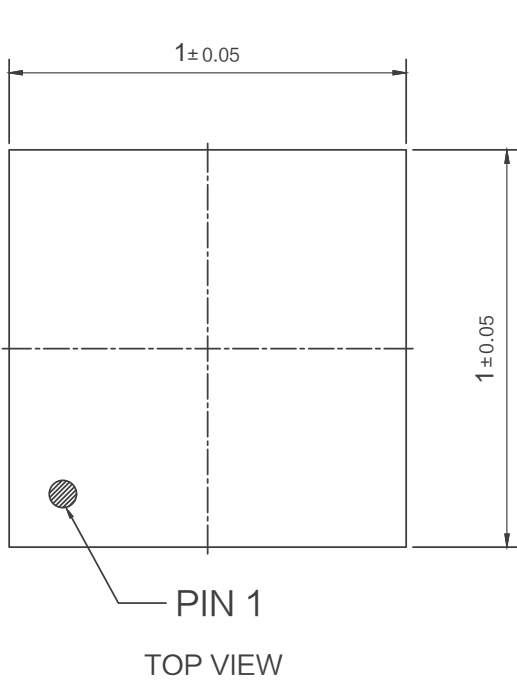

X-ON Electronics

Largest Supplier of Electrical and Electronic Components

Click to view similar products for [Linear Voltage Regulators](#) category:

Click to view products by [SLKORMICRO](#) manufacturer:

Other Similar products are found below :

[LV5684PVD-XH](#) [MCDTSA6-2R](#) [L7815ACV-DG](#) [LV56801P-E](#) [UA7805CKC](#) [714954EB](#) [ZMR500QFTA](#) [BA033LBSG2-TR](#)
[NCV78M05ABDTRKG](#) [LV5680P-E](#) [L79M05T-E](#) [L78LR05D-MA-E](#) [NCV317MBTG](#) [NTE7227](#) [MP2018GZD-33-P](#) [MP2018GZD-5-P](#)
[LV5680NPVC-XH](#) [ZTS6538SE](#) [UA78L09CLP](#) [UA78L09CLPR](#) [CAT6221-PPTD-GT3](#) [MC78M09CDTRK](#) [NCV51190MNTAG](#)
[BL1118CS8TR1833](#) [BL8077CKETR33](#) [BL9153-33CC3TR](#) [BL9161G-28BADRN](#) [BRCO7530MMC](#) [CJ7815B-TFN-ARG](#) [LM317C](#)
[GM7333K](#) [GM7350K](#) [XC6206P332MR](#) [HT7533](#) [LM7912S/TR](#) [LT1764S/TR](#) [LM7805T](#) [LM338T](#) [LM1117IMP-3.3/TR](#) [HT1117AM-3.3](#)
[HT7550S](#) [AMS1117-3.3](#) [HT7150S](#) [78L12](#) [HT7550](#) [HT7533-1](#) [HXY6206I-2.5](#) [HT7133](#) [HT7533S](#) [662K](#)