

## Low Dropout Regulators

### Description

SL9500 Series is high accuracy, very low quiescent current, low-dropout linear regulator able to provide 500mA load current.

SL9500 Series features very fast response against line voltage transient and load current transient, and ensures no overshoot voltage during the LDO start up and short circuit recovery.

SL9500 Series integrated short circuit protection, current limiting protection and thermal protection function. By putting the EN pin down to turn on shutdown mode.

### Features

- Wide Input Voltage Range: 1.8V~6V
- Maximum Output Current: 500mA
- Standard Fixed Output Voltage Options: 1.2V, 1.8V, 2.5V, 2.8V, 3V, 3.3V, 3.6V, etc
- Low Quiescent Current: 800nA
- PSRR=60dB@1KHz
- Low Dropout: 130mV @ 100mA
- Low Output Voltage Accuracy:  $\pm 2\%$
- Short Circuit Protection
- Current Limiting Protection
- Thermal Shutdown Protection
- Available Packages: SOT-23, SOT-23-3, SOT-89, SOT-23-5, DFN1x1-4L and SOT-89-5

### Applications

- Battery-Powered Equipment
- Smoke Detector and Sensor
- Micro Controller Applications

### Typical Application Circuit

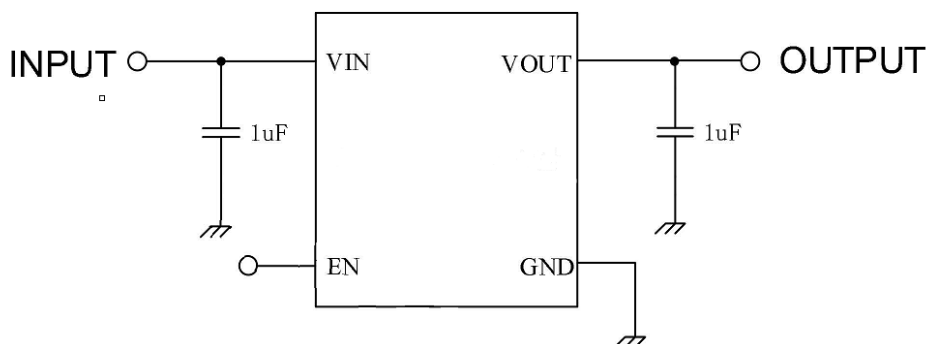

## Pin Distribution

**SOT-23**

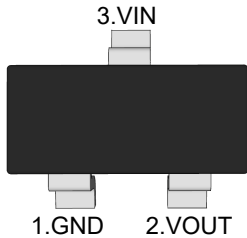

**SOT-89**

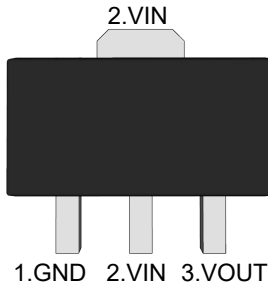

**SOT-23-3**

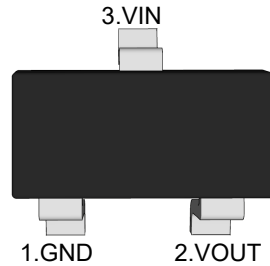

**SOT-23-5**

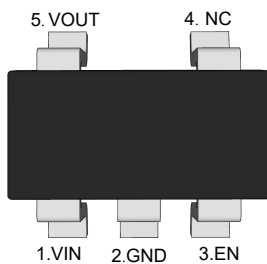

**DFN1x1-4L**

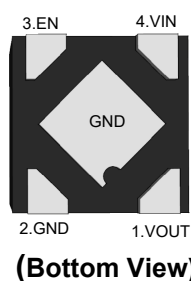

**SOT-89-5**

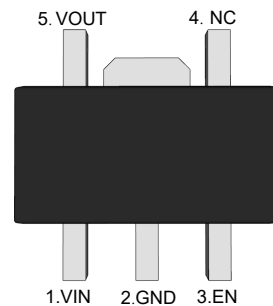

## Functional Pin Description

Pin Name	Pin Function
VIN	Power Input Voltage
GND	Ground
EN	Chip Enable (Active High). Note that this pin is high impedance
NC	NO Connected
VOUT	Output Voltage

## Ordering Information

SL9500 □ □ □ □

Package Type

SA:SOT-23 SQ:SOT-89

SC:SOT-23-3 SE:SOT-23-5

DE:DFN1x1-4L SR: SOT-89-5

Output Voltage

12 : 1.2V 18 : 1.8V 25 : 2.5V

28 : 2.8V 30 : 3.0V 33 : 3.3V



36 : 3.6V

Output current tap

M : 500mA

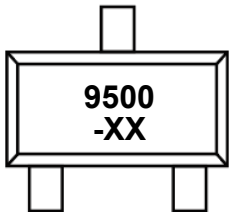
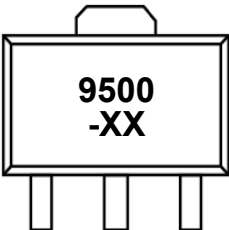
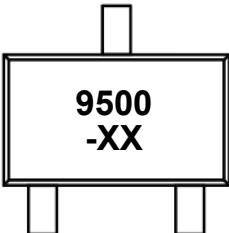
## Ordering Information Continue

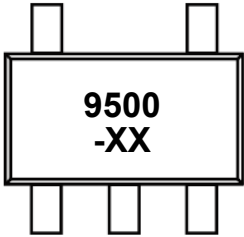
Orderable Device	Package	Reel (inch)	Package Qty (PCS)	Eco Plan <sup>Note</sup>	MSL Level	Marking Code
SL9500M12SA	SOT-23	7	3000	RoHS & Green	MSL1	 <p>XX:Output Voltage e.g. 3.0:3.0V</p>
SL9500M18SA						
SL9500M25SA						
SL9500M28SA						
SL9500M30SA						
SL9500M33SA						
SL9500M36SA						
SL9500M12SQ	SOT-89	7/13	1000/3000	RoHS & Green	MSL1	 <p>XX:Output Voltage e.g. 3.0:3.0V</p>
SL9500M18SQ						
SL9500M25SQ						
SL9500M28SQ						
SL9500M30SQ						
SL9500M33SQ						
SL9500M36SQ						
SL9500M12SC	SOT-23-3	7	3000	RoHS & Green	MSL3	 <p>XX:Output Voltage e.g. 3.0:3.0V</p>
SL9500M18SC						
SL9500M25SC						
SL9500M28SC						
SL9500M30SC						
SL9500M33SC						
SL9500M36SC						

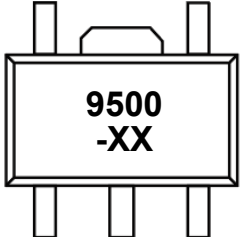
SL9500M12SE	SOT-23-5	7	3000	RoHS & Green	MSL3	 <p>XX:Output Voltage e.g. 3.0:3.0V</p>
SL9500M18SE						
SL9500M25SE						
SL9500M28SE						
SL9500M30SE						
SL9500M33SE						
SL9500M36SE						
SL9500M12DE	DFN1x1-4L	7	1000	RoHS & Green	MSL1	 <p>D:Product Code e.g. D: PJ9500 Series XX:Output Voltage e.g. 30:30V</p>
SL9500M18DE						
SL9500M25DE						
SL9500M28DE						
SL9500M30DE						
SL9500M33DE						
SL9500M36DE						
SL9500M12SR	SOT-89-5	7/13	1000/3000	RoHS & Green	MSL1	 <p>XX:Output Voltage e.g. 3.0:3.0V</p>
SL9500M18SR						
SL9500M25SR						
SL9500M28SR						
SL9500M30SR						
SL9500M33SR						
SL9500M36SR						

**Function Block Diagram**

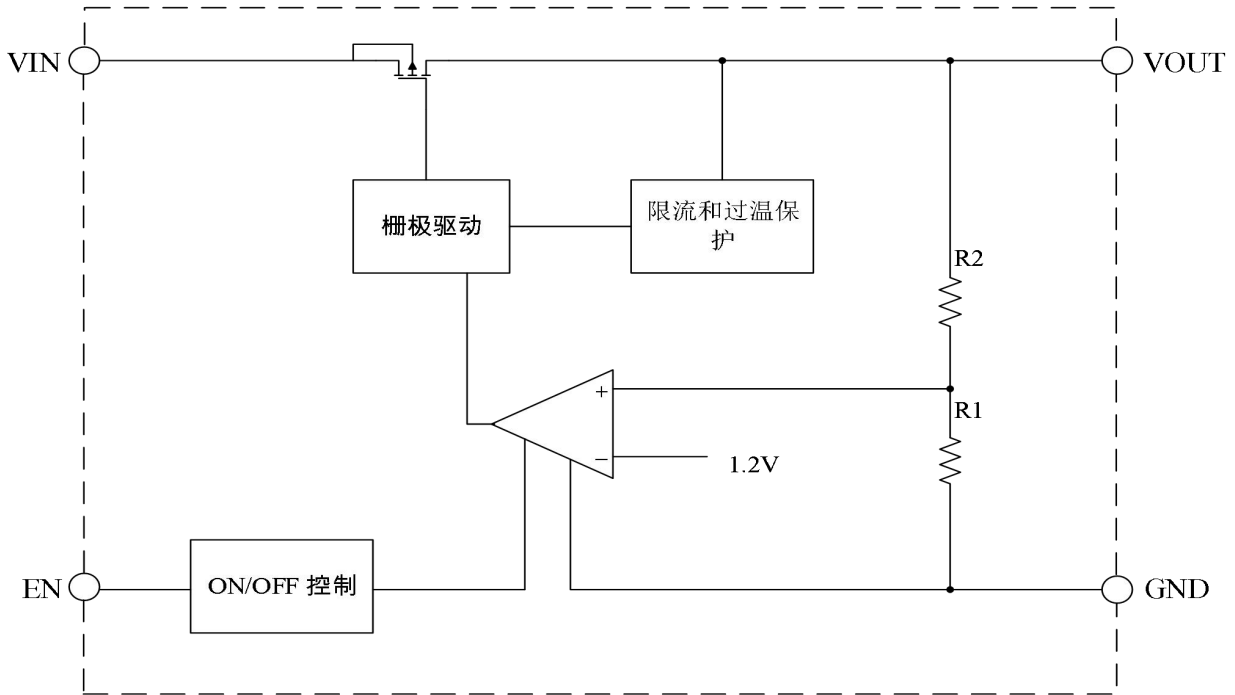

## Absolute Maximum Ratings <sup>Note1</sup>

Ratings at 25°C ambient temperature unless otherwise specified.

Parameter		Value	Unit
VIN, VEN to GND Voltage	V <sub>IN</sub>	-0.3 ~ 6	V
	V <sub>EN</sub>	-0.3 ~ 6	V
VO <sub>UT</sub> to V <sub>IN</sub> Voltage		-0.3 ~ 5	V
Maximum Load Current		500	mA
Power Dissipation	SOT-23	300	mW
	SOT-89	400	mW
	SOT-23-3	250	mW
	SOT-23-5	250	mW
	DFN1x1-4L	250	mW
	SOT-89-5	400	mW
Thermal Resistance, Junction-to-Ambient	SOT-23	330	°C/W
	SOT-89	250	°C/W
	SOT-23-3	400	°C/W
	SOT-23-5	400	°C/W
	DFN1x1-4L	400	°C/W
	SOT-89-5	250	°C/W
Operating Ambient Temperature		-40 ~ +125	°C
Storage temperature range		-40 ~ +150	°C
Lead Temperature		300°C, 10S	--
ESD Voltage	HBM	4	KV
	CDM	200	V

Note1: Exceed these limits to damage to the device. Exposure to absolute maximum rating conditions may affect.

## Recommended Operating Conditions

Parameter	Value	Unit
Supply Voltage	1.8~6	V
Maximum Output Current	500	mA
Operating Ambient Temperature	-40 ~ +125	°C

## Electrical Characteristics

$V_{IN}=V_{OUT}+1V$ ,  $C_{IN}=1\mu F$ ,  $C_{OUT}=1\mu F$ ,  $T_A=25^\circ C$ , unless otherwise noted.)

Parameter		Symbol	Test Conditions	Min.	Typ.	Max.	Unit
Input Voltage		$V_{IN}$		1.8	--	6	V
Output Voltage Accuracy		$\Delta V_{OUT}$	$V_{IN}=5V$ , $I_{OUT}=10mA$	-2	--	+2	%
Quiescent Current		$I_Q$	$V_{IN}=5.0V$ , $I_{OUT}=0A$	--	800	--	nA
Maximum Output Current		$I_{OUT\_Max}$		--	500	--	mA
Dropout Voltage <sup>Note</sup>		$V_{DROP}$	$V_{IN}=0.98*V_{OUT}$ , $I_{OUT}=100mA$ $V_{OUT}\geq 2.8V$	--	120	--	mV
			$V_{IN}=0.98*V_{OUT}$ , $I_{OUT}=100mA$ $1.8\leq V_{OUT}< 2.8V$	--	160	--	mV
			$V_{IN}=0.98*V_{OUT}$ , $I_{OUT}=100mA$ $V_{OUT}=1.5V$	--	190	--	mV
			$V_{IN}=0.98*V_{OUT}$ , $I_{OUT}=100mA$ $V_{OUT}=1.2V$	--	280	--	mV
Line Regulation		$\Delta V_{LINE}$	$V_{IN}=(V_{OUT}+2V)\sim 7V$ , $I_{OUT}=1mA$	--	1	3	mV
Load Regulation		$\Delta V_{LOAD}$	$V_{OUT}=4V$ , $I_{OUT}=1\sim 200mA$	--	0.1	0.2	mV/mA
Short Circuit Current		$I_{SHORT}$	$V_{EN}=V_{IN}$ $V_{OUT}$ Short to GND	--	120	150	mA
Current Limit		$I_{LIMIT}$	$V_{IN}=V_{OUT}+1V$	--	700	--	mA
EN Input Threshold	Logic Low	$V_{IL}$		--	--	0.9	V
	Logic High	$V_{IH}$		1.1	--	--	V
Power Supply Rejection Rate		PSRR	$V_{IN}=5V$ , $I_{OUT}=10mA$ , $f=1\text{ KHz}$	--	60	--	dB
Output Noise Voltage		eN	$V_{IN}=5V$ , $I_{OUT}=300mA$ , $f=10Hz$ to $100KHz$ , ( $V_{OUT}=3.3V$ ), $C_{OUT}=1\mu F$	--	66	--	$\mu V_{RMS}$
Thermal Shutdown Temperature		$T_{SHDN}$	Shutdown, Temp increasing	--	129	--	$^\circ C$
Thermal Reset Temperature			Reset, Temp decreasing	--	105	--	$^\circ C$

Note: The dropout voltage difference is the voltage difference between the input and output, where the output voltage is 2% lower than its nominal value.

## Typical Electrical Curves

$T_A=25^\circ\text{C}$ , (unless otherwise noted)

Line transient

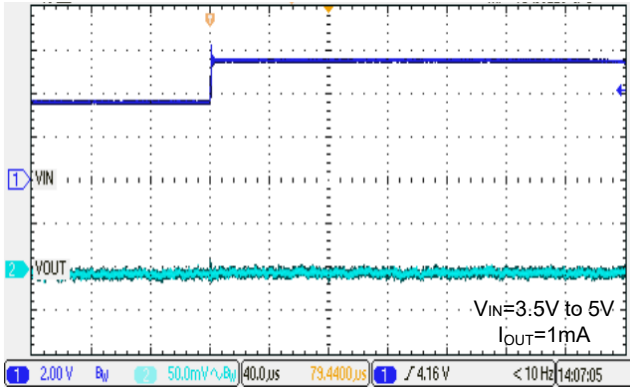

Line transient

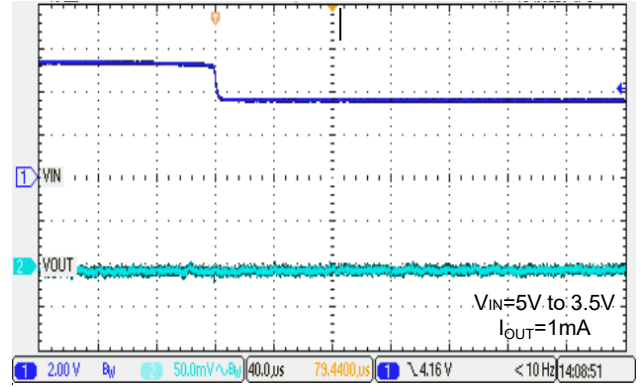

Load transient

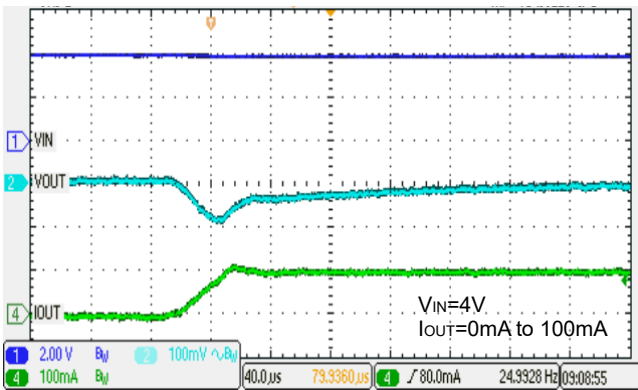

Load transient

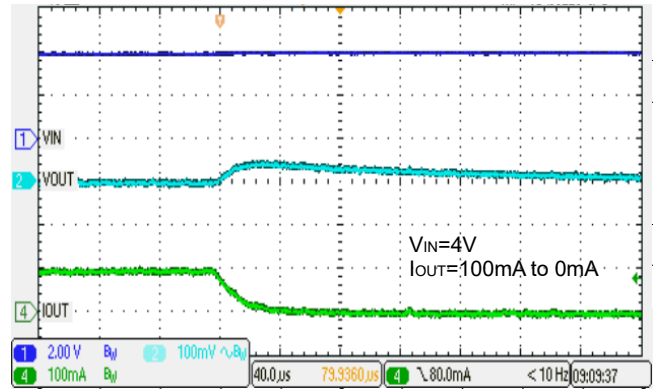

Power-on waveform

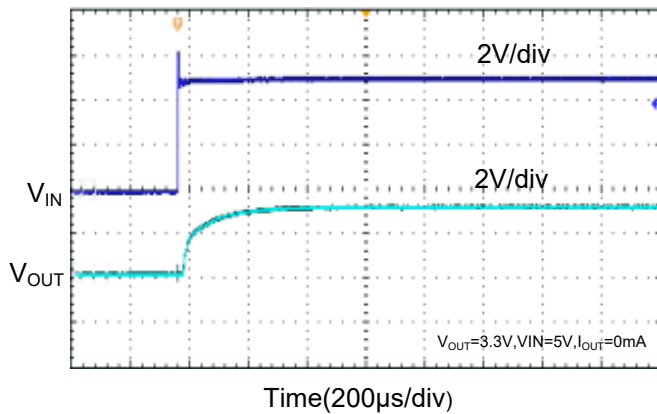

Power-off waveform

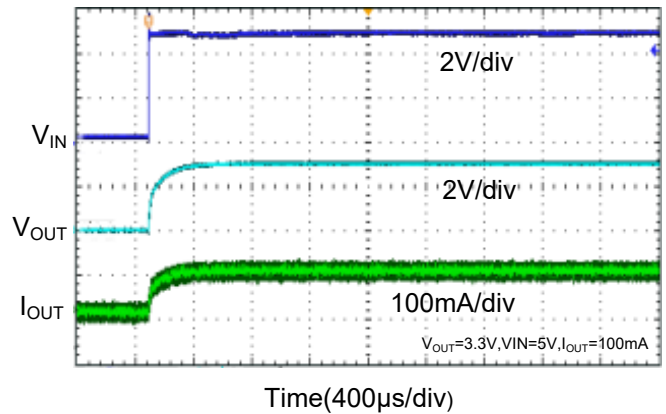



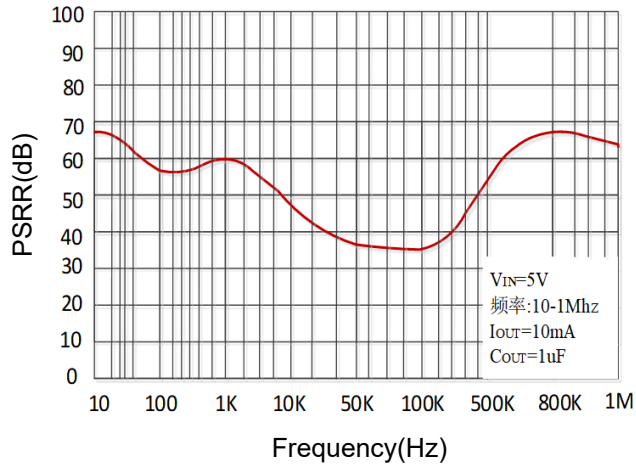

## Functional Description

### Input Capacitor

A 1 $\mu$ F ceramic capacitor is recommended to connect between VIN and GND pins to decouple input power supply glitch and noise. The amount of the capacitance may be increased without limit. This input capacitor must be located as close as possible to the device to assure input stability and less noise. For PCB layout, a wide copper trace is required for both VIN and GND. The input capacitor should be at least equal to, or greater than, the output capacitor for good load transient performance.

### Output Capacitor

An output capacitor is required for the stability of the LDO. The recommended output capacitance is from 1 $\mu$ F to 10 $\mu$ F, Equivalent Series Resistance (ESR) is from 5m $\Omega$  to 500m $\Omega$ , and temperature characteristics are X7R or X5R. Higher capacitance values help to improve load/line transient response. The output capacitance may be increased to keep low undershoot/overshoot. Place output capacitor as close as possible to OUT and GND pins.

### ON/OFF Input Operation

The SL9500 EN pin is internally held low by a 1-M $\Omega$  resistor to GND. The PJ9500 is turned on by setting the EN pin higher than VIH threshold, and is turned off by pulling it lower than VIL threshold. If this feature is not used, the EN pin should be tied to IN pin to keep the regulator output on at all time.

### Low Quiescent Current

Cellular phone baseband internal digital circuits typically operate all the time. That requires LDO stays on at all times. However, in the standby mode, the microprocessor consumes only around 100~300 $\mu$ A. Since the phone stays in standby for the longest percentage of time, using a 0.8 $\mu$ A quiescent current LDO, instead of 100 $\mu$ A, saves 99.2 $\mu$ A and can substantially extend the battery standby time.

The SL9500, consuming only 0.8 $\mu$ A quiescent current, provides great power saving in portable and low power applications.

### Current Limit Protection

When output current at the OUT pin is higher than current limit threshold or the OUT pin is short-circuiting to GND, the current limit protection will be triggered and clamp the output current to a pre-set level to prevent over-current and to protect the regulator from damage due to overheating.

### Thermal Overload Protection

The 9500 has internal thermal protection. When the temperature is too high, such as a short circuit in the output pins or a device with a very large load current and a large voltage drop, the internal thermal protection circuit will be triggered, which will shut down the power supply MOSFET and prevent LDO damage. Once the excessive thermal conditions are eliminated and the temperature of the device drops, the thermal protection circuit will restore control of the power MOSFET and allow the LDO device to enter normal operation

## Package Outline

SOT-23

Dimensions in mm

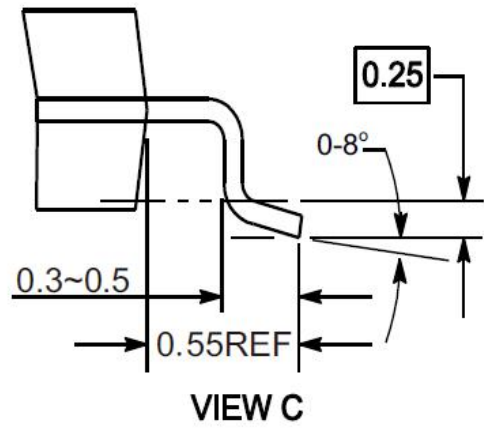
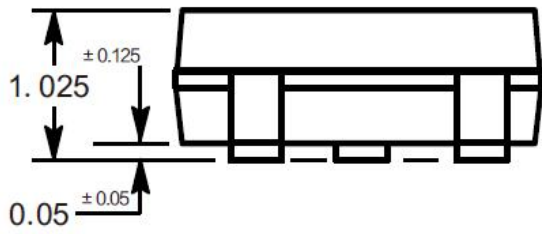
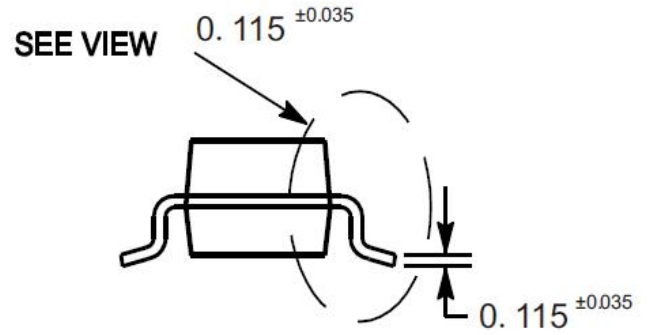
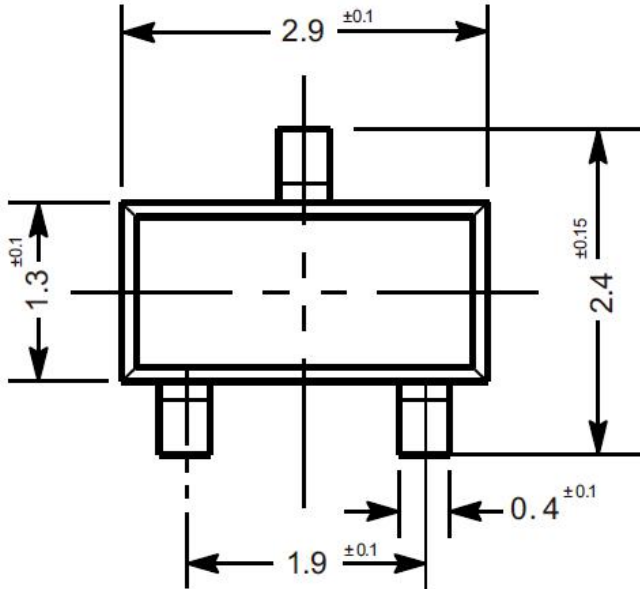

## Package Outline

SOT-89

Dimensions in mm

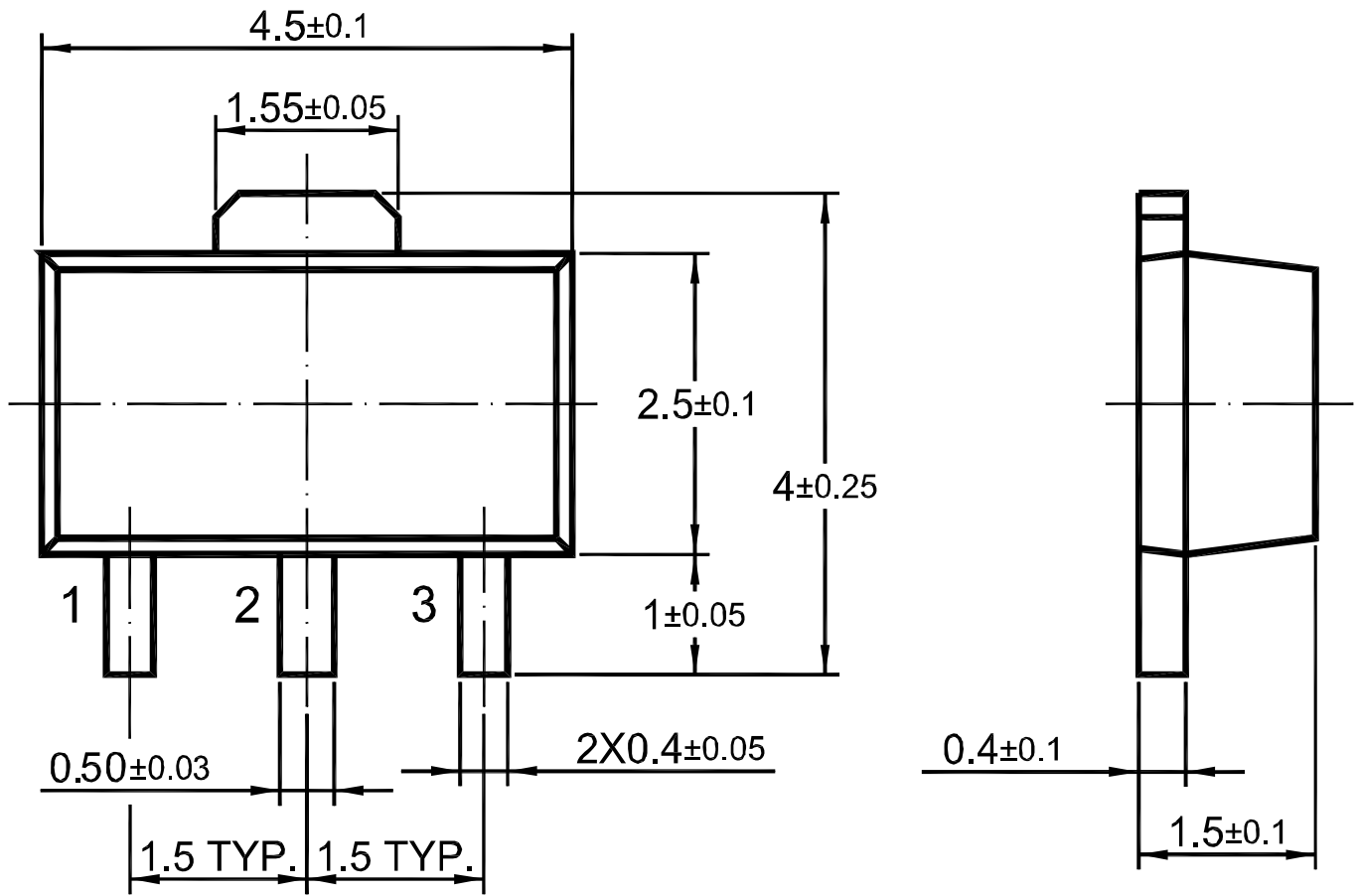

## Package Outline

SOT-23-3

Dimensions in mm

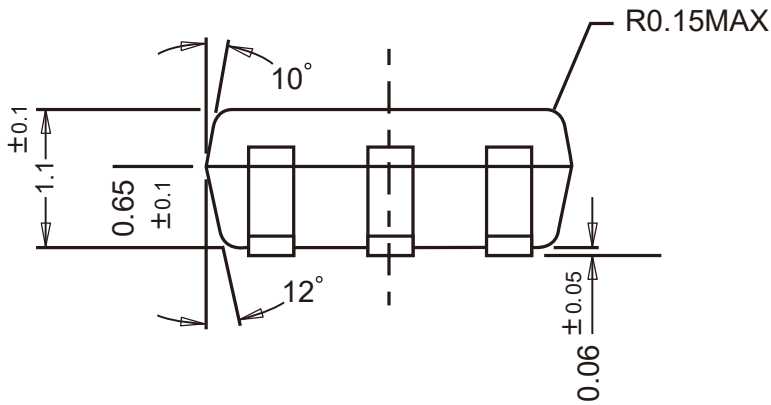
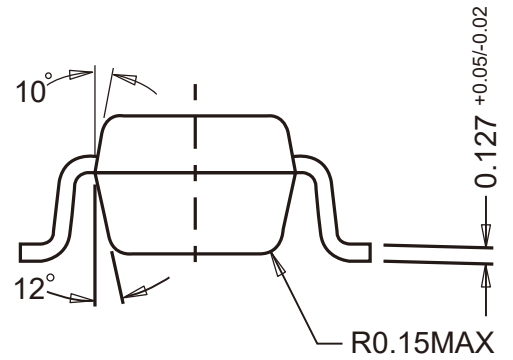
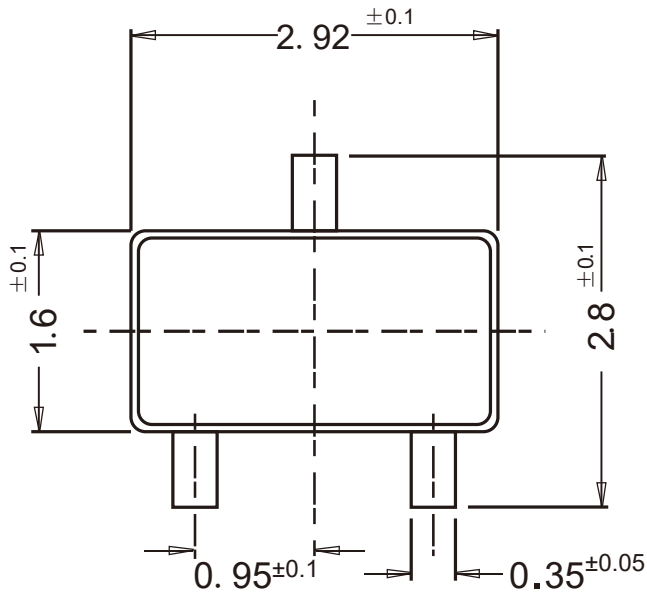

## Package Outline

SOT-23-5

Dimensions in mm

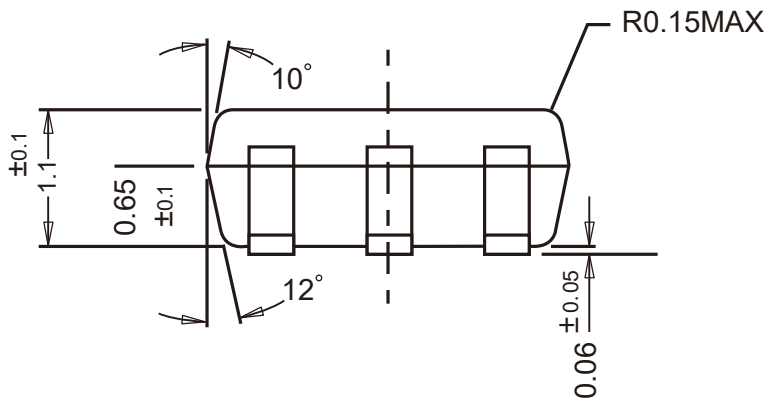
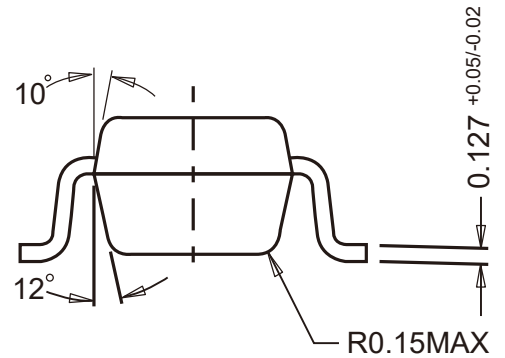
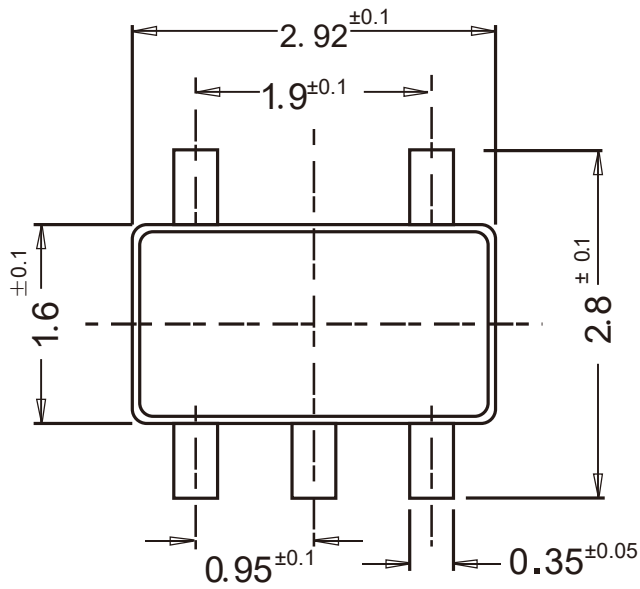

## Package Outline

DFN1x1-4L

Dimensions in mm

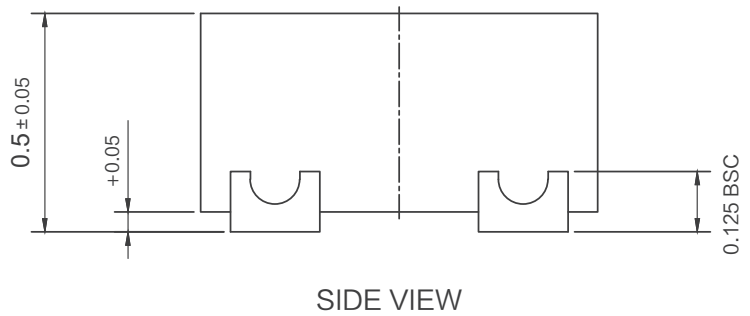
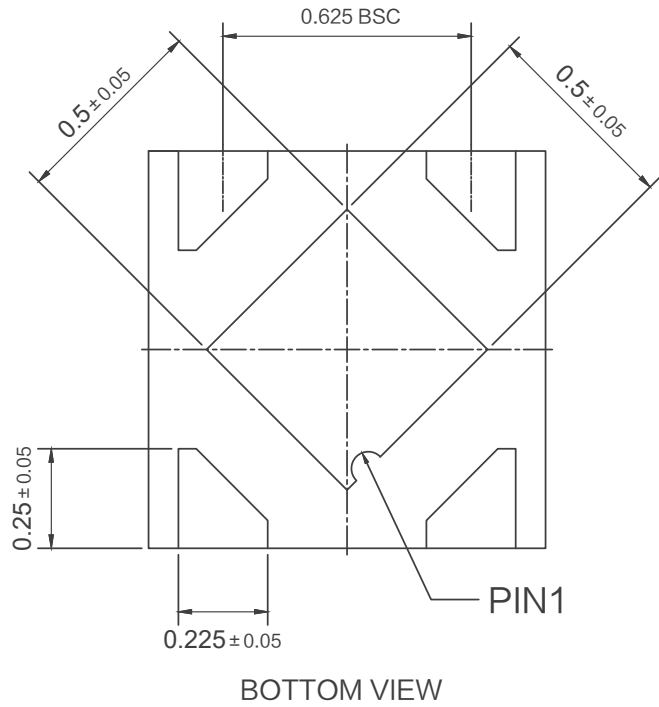
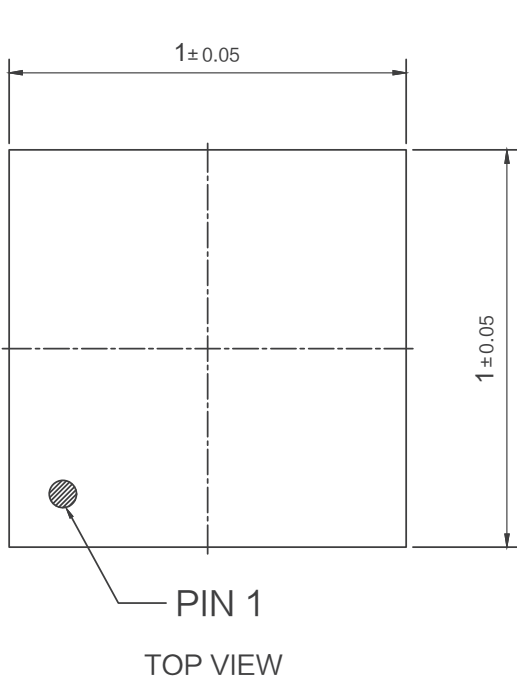

## Package Outline

SOT-89-5

Dimensions in mm

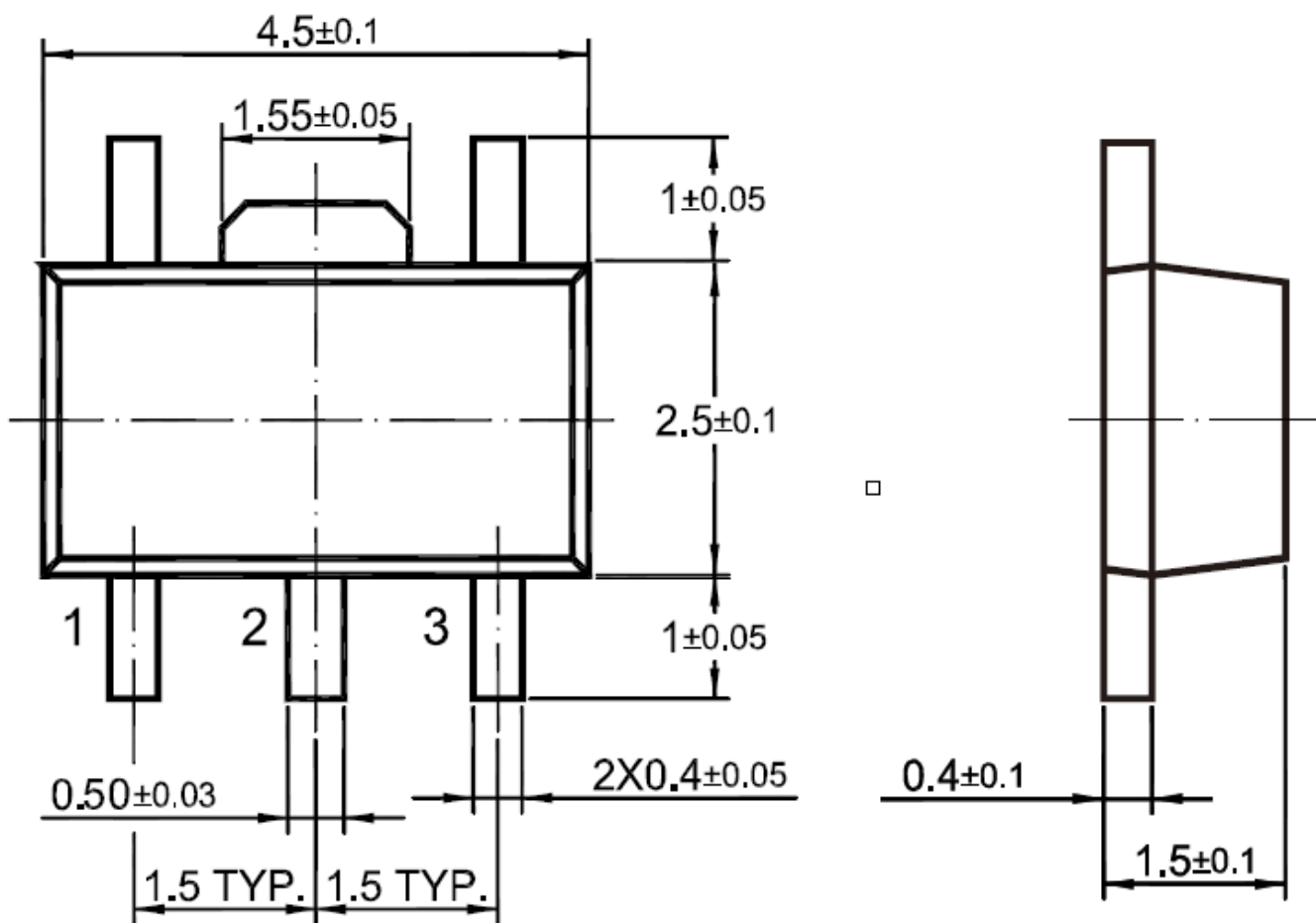



## X-ON Electronics

Largest Supplier of Electrical and Electronic Components

*Click to view similar products for [Linear Voltage Regulators](#) category:*

*Click to view products by [SLKORMICRO](#) manufacturer:*

Other Similar products are found below :

[LV5684PVD-XH](#) [MCDTSA6-2R](#) [L7815ACV-DG](#) [714954EB](#) [ZMR500QFTA](#) [BA033LBSG2-TR](#) [LV5680P-E](#) [L79M05T-E](#) [L78LR05D-MA-E](#) [NCV317MBTG](#) [NTE7227](#) [MP2018GZD-33-P](#) [MP2018GZD-5-P](#) [LV5680NPVC-XH](#) [LT1054CN8](#) [ZTS6538SE](#) [UA78L09CLP](#) [UA78L09CLPR](#) [CAT6221-PPTD-GT3](#) [MC78M09CDTRK](#) [NCV51190MNTAG](#) [78M05](#) [HT7150-1](#) [UM1540DB-18](#) [XC6234H281VR-G](#) [WL2834CA-6/TR](#) [TPL730F33-5TR](#) [TLS850F1TA](#) [V50](#) [TPS549B22RVFR](#) [UM1540DB-33](#) [WL9200P3-50B](#) [WL9100P3-33B](#) [WL9005D4-33](#) [XC6219B152MR](#) [WL2855K33-3/TR](#) [PJ54BM33SE](#) [PJ9500M25SA](#) [MD7218E33PC1](#) [H7533-2PR](#) [SK7812AU](#) [SD1A30](#) [78L33](#) [TP78L33T3](#) [L78L33ACUTR](#) [SK6513ST3A-50](#) [SK6054D4-09](#) [SK6054D4-18](#) [SK6054D4-11](#) [SK6054D4-10](#) [LM79L12F](#)