

Low Dropout Regulators

Description

The SL9650 Series is a low dropout, positive linear regulator with very low quiescent current. It can supply 600mA output current with an input range from 1.7V to 7V, which makes it suitable for all kinds of applications.

SL9650 Series use advanced CMOS technology to achieve very low dropout voltage (300mV @600mA). Fast structural design achieves 75dB PSRR at 1kHz while still maintaining a small 50uA quiescent current.

Trimming technique is used to guarantee output voltage accuracy within $\pm 2\%$ (Fixed Output); $\pm 1\%$ (Adjustable Output). SL9650 Series provides full fault protection including current limit, short circuit protection and thermal shutdown protection.

Features

- Fixed Output Voltages:
0.7V, 1.0V, 1.2V, 1.5V, 1.8V, 2.5V, 2.8V, 3.0V, 3.3V, 3.6V, Other output can be customized
- Adjustable Output from 0.6V to (VIN-VDROP)
- Maximum Output Current: 600mA
- Input Voltage Range: 1.7V~7V
- Low Quiescent Current: 50uA (Typ.)
- Very low dropout voltage:
300mV @ 600mA (Vout=3.3V)
- Highly Accurate: $\pm 2\%$ (Fixed Output)
 $\pm 1\%$ (Adjustable Output)
- 0.02%/V Line Regulation
- Auto discharge function
- 75dB PSRR @ 1KHz
- -40°C~125°C Wide Operating Temperature
- 2000V HBM ESD
- 150 °C Thermal Protection

Applications

- Battery powered portable devices
- Smart phone, tablet
- Hi resolution camera sensor power
- Wireless modules
- RF, PLL, VCO clock power

SOT-23

3.VIN

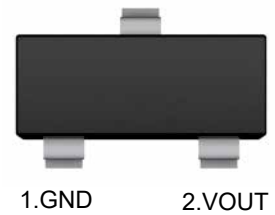

SOT-23-3

3.VIN

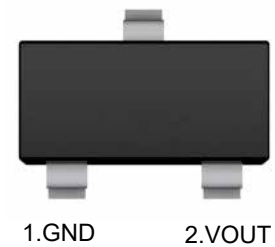

SOT-89

2.VIN

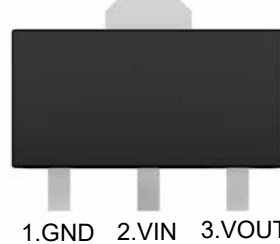

SOT-89-5

5.VOUT 4.VIN

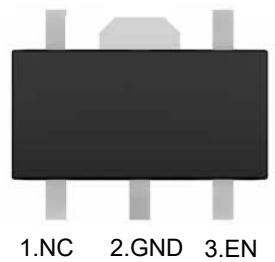

SOT-23-5 Fixed

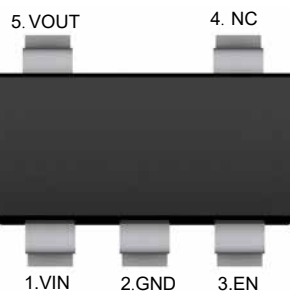

SOT-23-5 ADJ

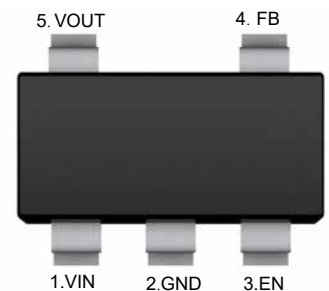

DFN1x1-4L

Bottom View

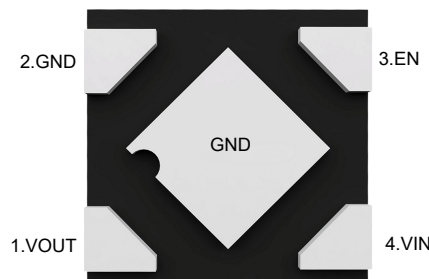

DFN2x2C-6L

Bottom View

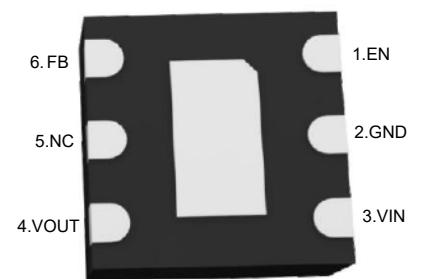

Functional Pin Description

Pin Name	Pin Function
VIN	Power Input Voltage
GND	Ground
EN	Chip Enable (Active High). Note that this pin is high impedance
NC	NO Connected
FB	Feedback Pin (adjustable voltage version only). Connect this pin to the midpoint of an external resistor divider to adjust the output voltage
VOUT	Output Voltage

Marking Code

1.SOT

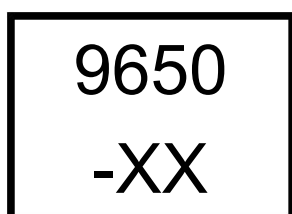

XX:Output Voltage
e.g. 3.0:3.0V
AJ:ADJ

2.DFN

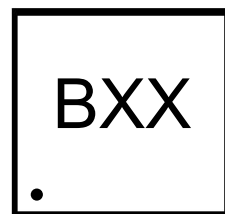

B:Product Code
XX:Output Voltage
e.g. 30:3.0V

Ordering Information

SL9650 □□□□

- Package Type
 - SA:SOT-23 SC:SOT-23-3
 - SQ:SOT-89 SR:SOT-89-5
 - SE:SOT-23-5 DE:DFN1x1-4L
 - DFC:DFN2x2C-6L
- Fixed Output Voltage Version
 - 10 : 1.0V 12 : 1.2V 15 : 1.5V
 - 18 : 1.8V 25 : 2.5V 28 : 2.8V
 - 30 : 3.0V 33 : 3.3V 36 : 3.6V
 - ADJ: Adjustable Output Voltage Version
- Output current tap
 - M : 600mA

Function Block Diagram(Package in SOT-23-5)

Fixed Output Voltage

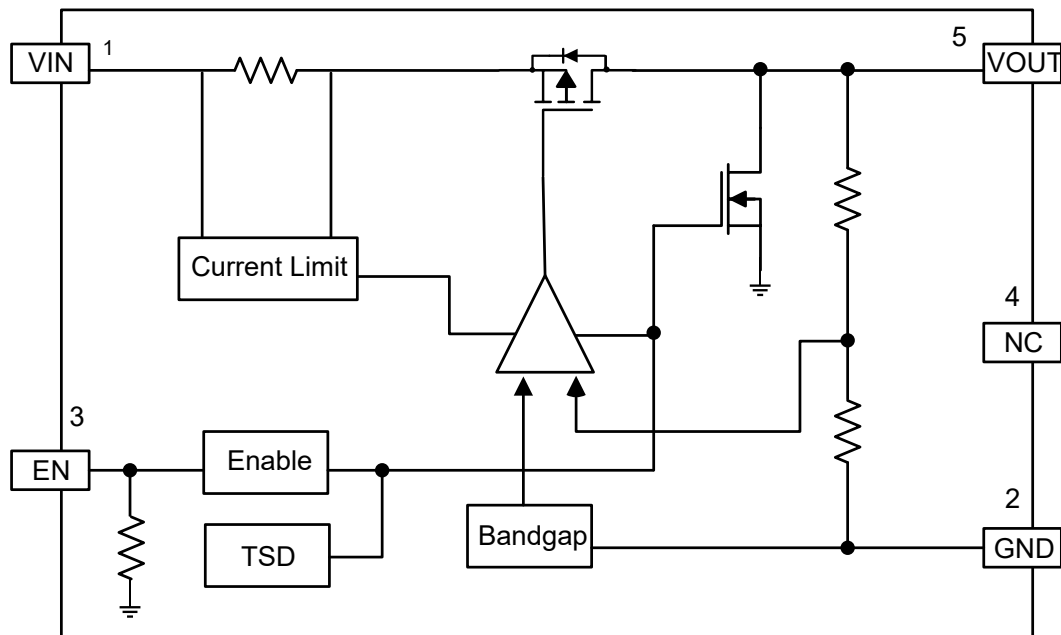

Adjustable Output Voltage

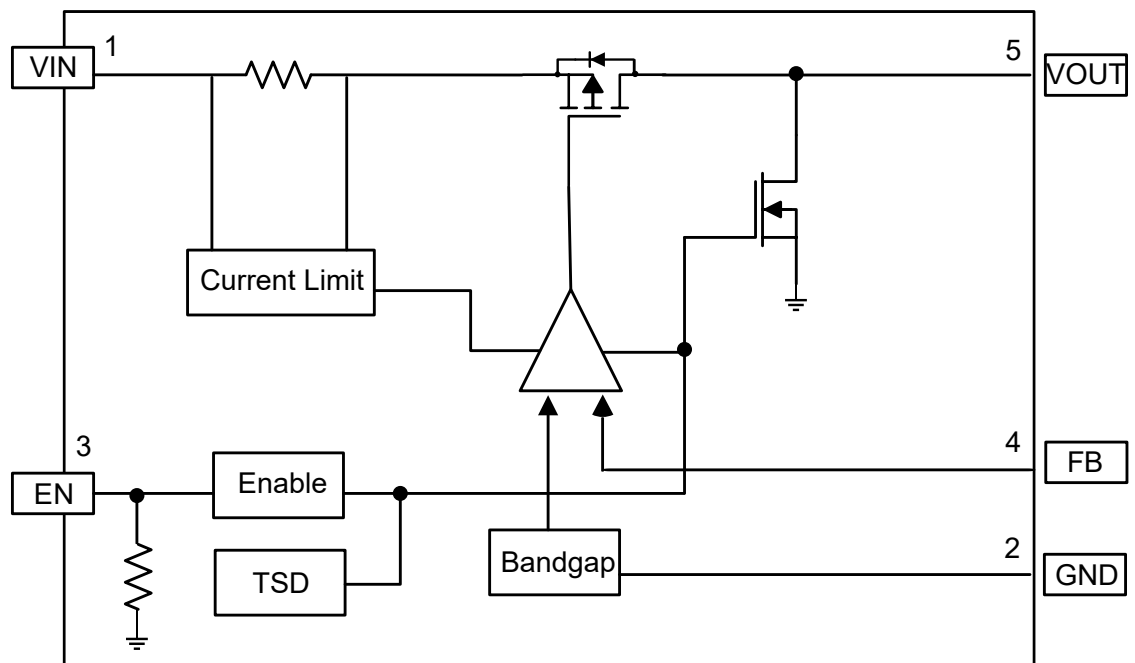

Typical Application Circuit

Fixed Output Voltage

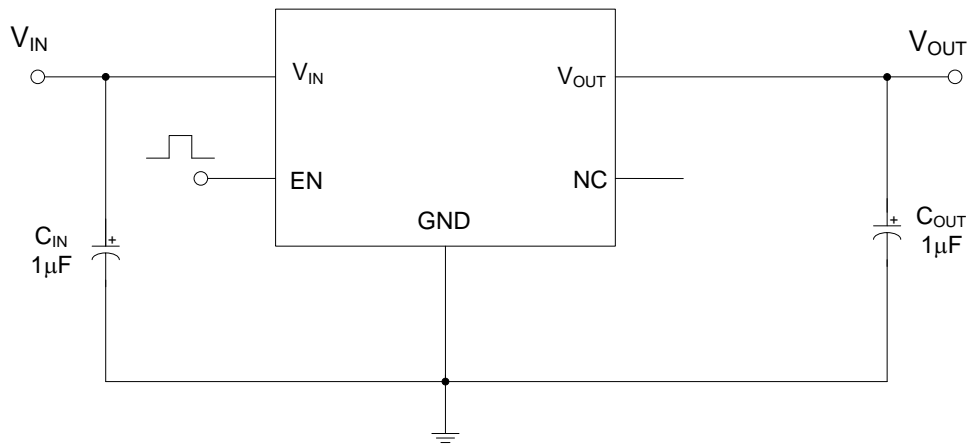

Adjustable Output Voltage

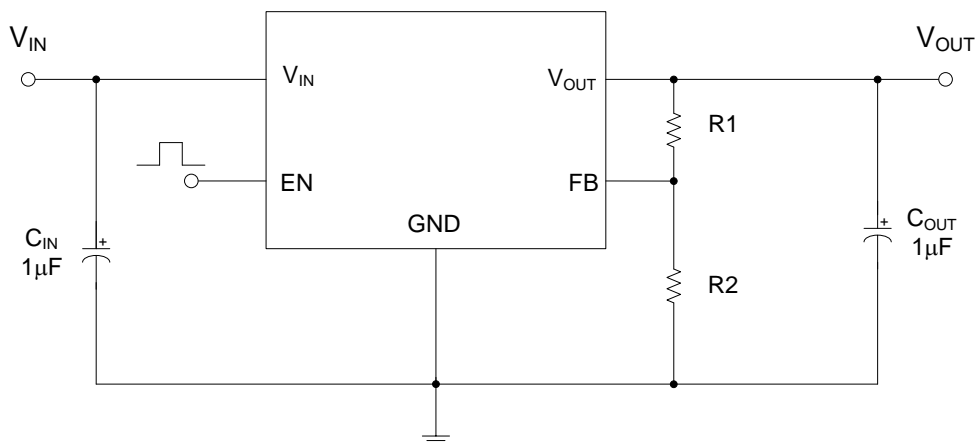

Note:

1. Input capacitor ($C_{IN}=1\mu F$) and Output capacitor ($C_{OUT}=1\mu F$) are recommended in all application circuit.
2. $V_{OUT}=V_{FB} \times (1+R1/R2)$, $V_{FB}=0.6V$.

Absolute Maximum Ratings

Ratings at 25°C ambient temperature unless otherwise specified.

Parameter		Value	Unit
Maximum Input Voltage		8.5	V
Output Current		600	mA
Power Dissipation	SOT-23	350	mW
	SOT-89	590	mW
	SOT-23-3	450	mW
	SOT-23-5	450	mW
	DFN1x1-4L	550	mW
Thermal Resistance, Junction-to-Ambient	SOT-23	280	°C/W
	SOT-89	170	°C/W
	SOT-23-3	220	°C/W
	SOT-23-5	220	°C/W
	DFN1x1-4L	180	°C/W
Maximum Junction Temperature		150	°C
Operating Ambient Temperature		-40 ~ +125	°C
Storage Temperature Range		-55~ +150	°C
Lead Temperature&Time		260°C, 10S	--

Note1: Exceed these limits to damage to the device. Exposure to absolute maximum rating conditions may affect.

Recommended Operating Conditions

Parameter	Value	Unit
Supply Voltage	1.7~7	V
Maximum Output Current	600	mA
Operating Ambient Temperature	-40 ~ +125	°C

Electrical Characteristics

$C_{IN}=1\mu F$, $C_{OUT}=1\mu F$, $T_A=25^\circ C$, unless otherwise noted.)

Parameter	Symbol	Test Conditions	Min.	Typ.	Max.	Unit	
Input Voltage	V_{IN}		1.7	--	7	V	
Output Voltage Range	V_{OUT}	$V_{IN}=V_{OUT}+1V$ $1mA < I_{OUT} < 30mA$	V_{OUT} $\times 0.98$	--	V_{OUT} $\times 1.02$	V	
Feedback Voltage	V_{FB}	Adjustable Output Version	--	0.6	--	V	
Output Voltage Accuracy	ΔV_{OUT}	Fixed Output Version	-2	--	+2	%	
		Adjustable Output Version	-1	--	+1	%	
Quiescent Current	I_Q	$I_{OUT}=0mA$	--	50	75	μA	
Max. Output Current	$I_{OUT} (Max.)$	$V_{IN}-V_{OUT}=1V$	600	--	--	mA	
Dropout Voltage	V_{DROP}	$V_{OUT}=3.3V$, $I_{OUT}=600mA$	--	300	500	mV	
Line Regulation	ΔV_{LINE}	$I_{OUT}=1mA$	--	0.02	0.1	%/V	
Load Regulation	ΔV_{LOAD}	$0mA \leq I_{OUT} \leq 600mA$	--	15	30	mV	
Short Circuit Current	I_{SHORT}		--	250	--	mA	
Current Limit	I_{LIM}	$V_{IN}-V_{OUT}=1V$	0.7	0.75	--	A	
Standby Current		EN=0	--	--	1	μA	
EN Input Threshold	Logic Low	V_{CEL}	EN Low Voltage	--	--	0.4	V
	Logic High	V_{CEH}	EN High Voltage	1	--	--	V
Power Supply Rejection Rate	PSRR	$V_{IN}=V_{OUT}+0.5V$, $f=1KHz$, $I_{OUT}=10mA$	--	75	--	dB	
Startup Time	t_{start}		--	80	--	μS	
Output Voltage Temperature Coefficient	TC_{VOUT}		-100	--	100	ppm/ $^\circ C$	
OTP			130	150	170	$^\circ C$	
OTP Hysteresis			--	40	--	$^\circ C$	

Note: All test are conducted under ambient temperature $25^\circ C$ and within a short period of time 20ms.

Typical Electrical Curves

Test conditions: $V_{EN}=V_{IN}$, $C_{IN}=C_{OUT}=1\mu F$, all typical values are at $T_A=25^\circ C$ (unless otherwise noted)

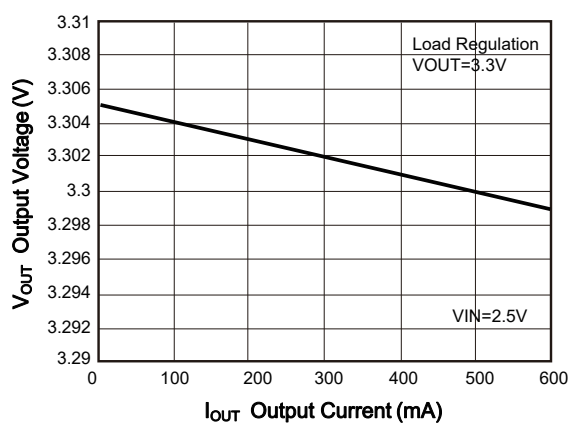
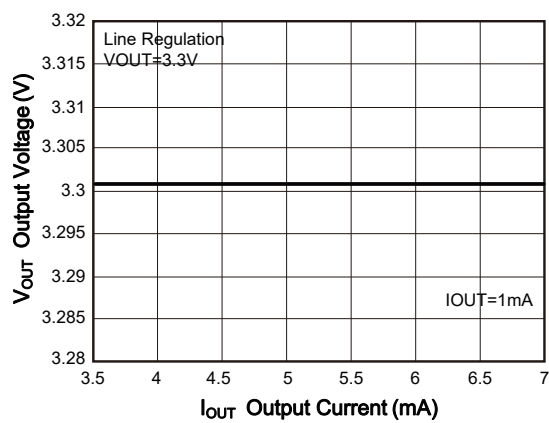
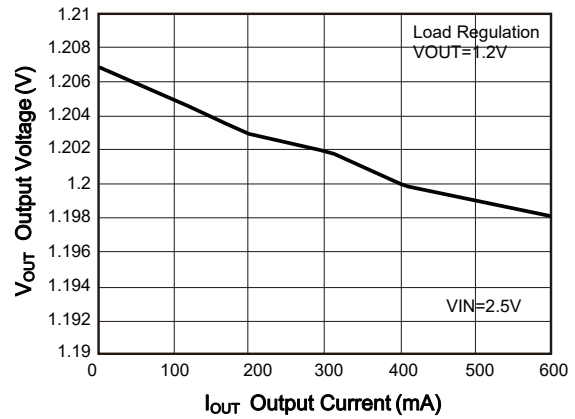
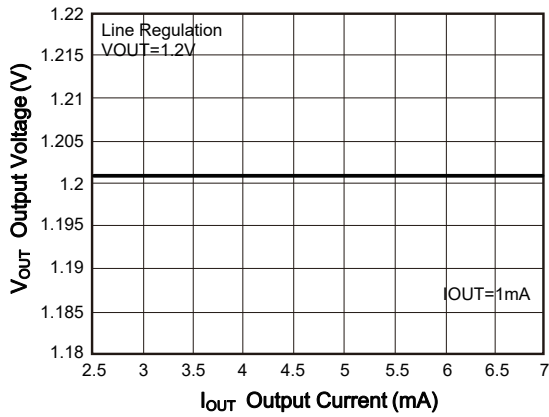
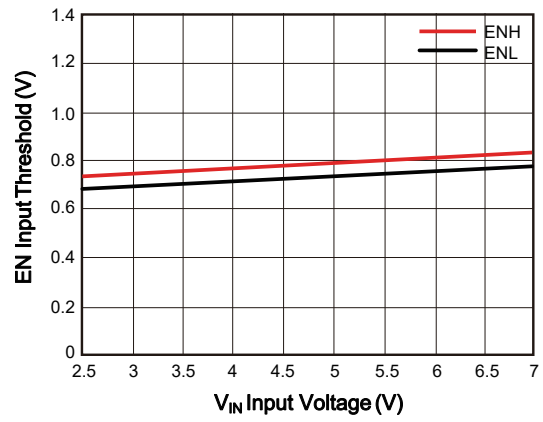
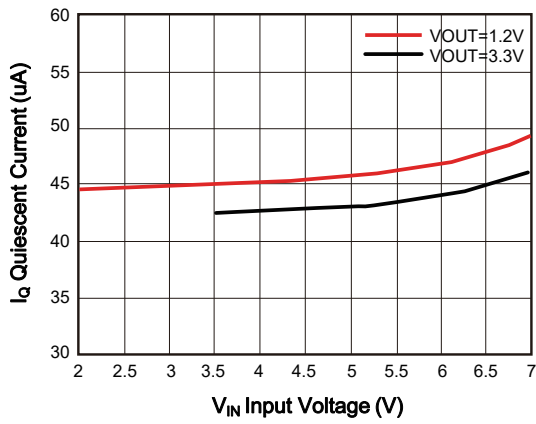

Typical Electrical Curves

Test conditions: $V_{EN}=V_{IN}$, $C_{IN}=C_{OUT}=1\mu F$, all typical values are at $T_A=25^\circ C$ (unless otherwise noted)

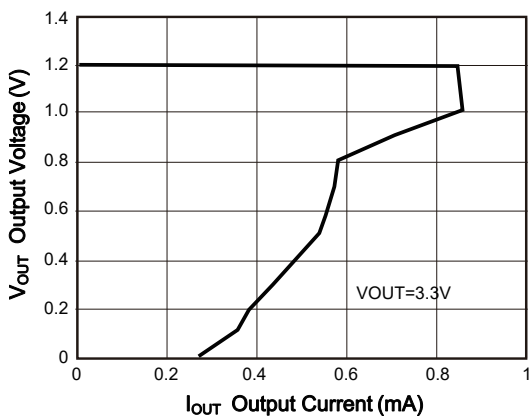
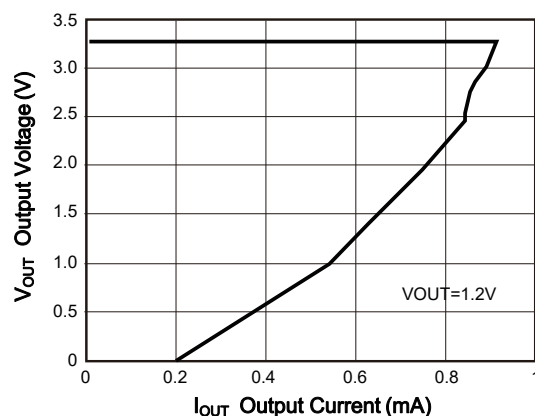
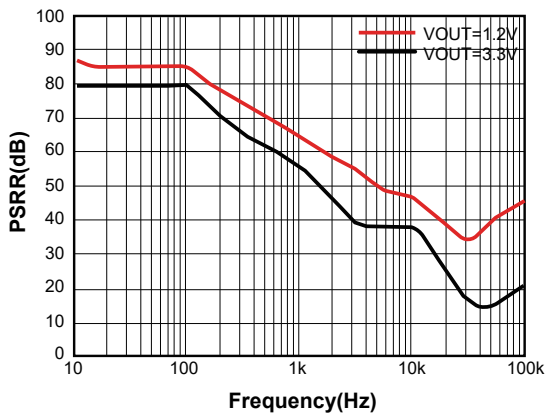
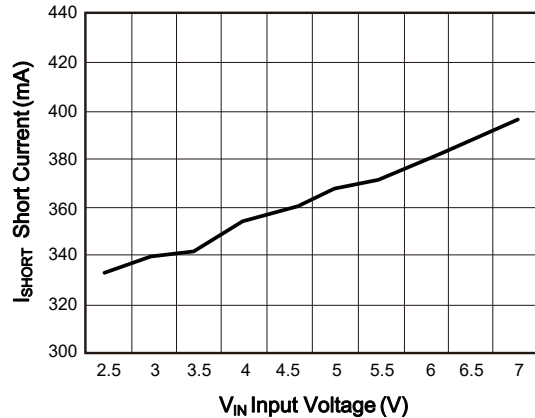
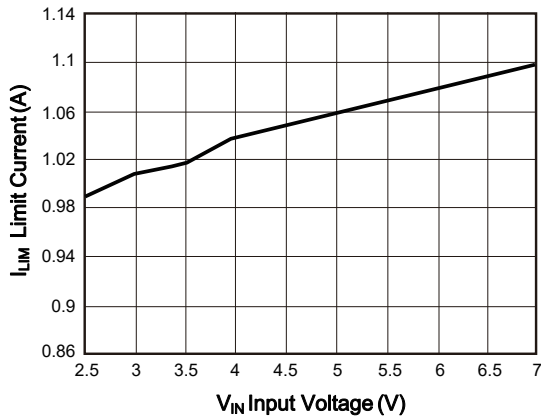
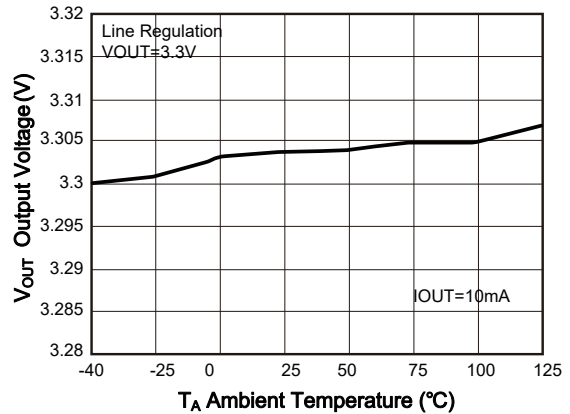
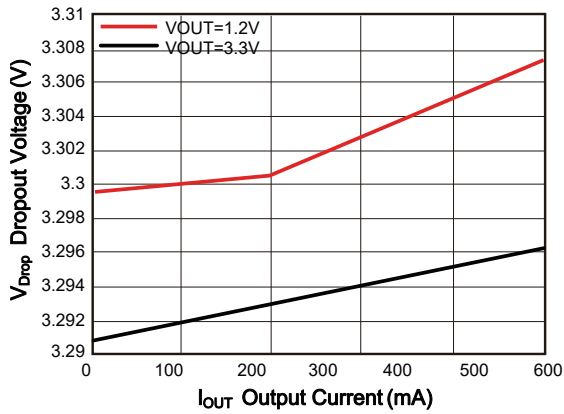

Typical Electrical Curves

Test conditions: $V_{EN}=V_{IN}$, $C_{IN}=C_{OUT}=1\mu F$, all typical values are at $T_A=25^\circ C$ (unless otherwise noted)

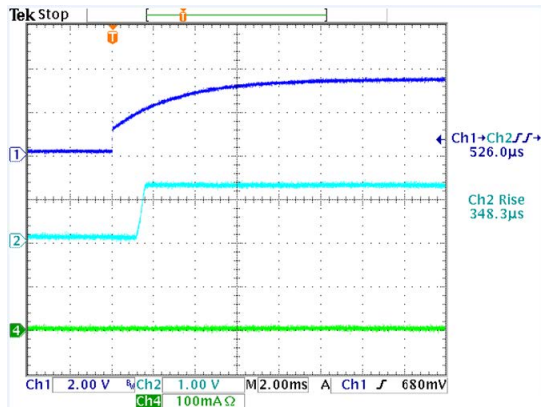

Power ON(VOUT=1.2V)

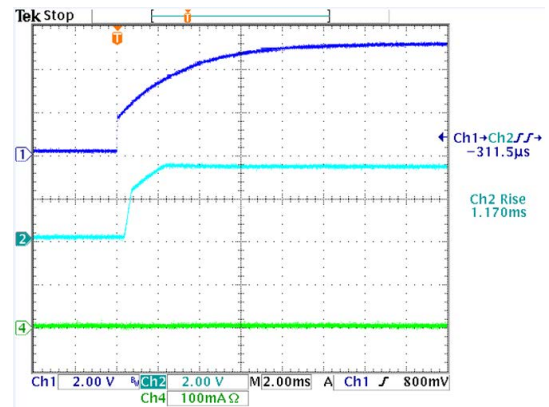

Power ON(VOUT=3.3V)

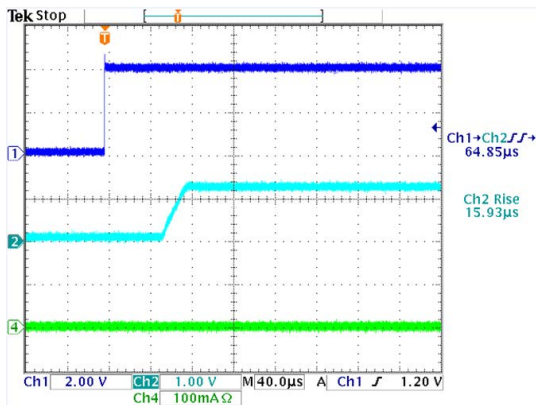

EN ON(VOUT=1.2V)

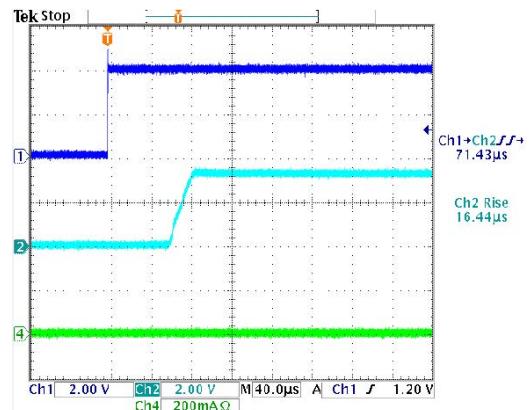

EN ON(VOUT=3.3V)

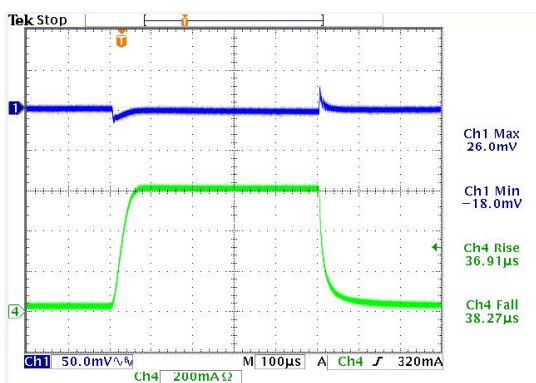

Load Transient VOUT=1.2V, VIN=3.3V

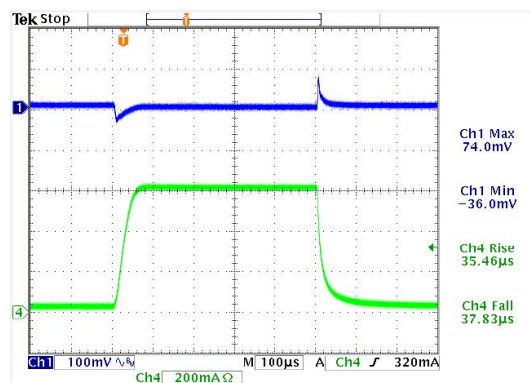

Load Transient VOUT=3.3V, VIN=5V

Function Descriptions

A minimum of 1 μ F capacitor must be connected from Vout to ground to insure stability. Input capacitor of 1 μ F is recommended to ensure the input voltage does not sag below the minimum dropout voltage during load transient event. Vin pin must always be dropout voltage higher than Vout in order for the device to regulate properly.

Application Information

SL9650 Series requires input and output decoupling capacitors. The device is specifically designed for portable applications requiring minimum board space and smallest components. These capacitors must be correctly selected for good performance. Please note that linear regulators with a low dropout voltage have high internal loop gains, which require care in guarding against oscillation caused by insufficient decoupling capacitors.

Capacitor Selection

Normally, use a 1 μ F capacitor on the input and a 1 μ F capacitor on the output of the SL9650 Series. Larger input capacitor values and lower ESR (X5R, X7R) provide better supply noise rejection and transient response. A higher value output capacitor (2.2 μ F) may be necessary if large, fast transients are anticipated and the device is located several inches from the power source.

Input-Output (Dropout) Voltage

A regulator's minimum input-to-output voltage differential (dropout voltage) determines the lowest usable supply voltage. In battery-powered systems, this determines the useful end-of-life battery voltage. Because the device uses a PMOS, its dropout voltage is a function of drain to source on resistance, RDS (on), multiplied by the load current:

$$VDROP = VIN - VOUT = RDS (on) \times IOUT$$

Current Limit and Thermal Shutdown Protection

In order to prevent overloading or thermal condition from damaging the device, SL9650 Series has internal thermal and current limiting functions designed to protect the device. It will rapidly shut off PMOS pass element during overloading or over temperature condition.

Thermal Considerations

The SL9650 Series can deliver a current of up to 300mA over the full operating junction temperature range. However, the maximum output current must be controlled at higher ambient temperature to ensure the junction temperature does not exceed 150°C. With all possible conditions, the junction temperature must be within the range specified under operating conditions. Power dissipation can be calculated based on the output current and the voltage drop across regulator.

$$PD = (VIN - VOUT) \times IOUT$$

The final operating junction temperature for any set of conditions can be estimated by the following thermal equation:

$$PD (max) = (Tj (max) - Ta) / R\theta JA$$

Where Tj (max) is the maximum junction temperature of the die (150°C) and Ta is the maximum ambient temperature.

PCB Layout

An input capacitance of $\approx 1 \mu$ F is required between the SL9650 Series input pin and ground (the amount of the capacitance may be increased without limit), this capacitor must be located a distance of not more than 1cm from the input and return to a clean analog ground. Input capacitor can filter out the input voltage spikes caused by the surge current due to the inductive effect of the package pin and the printed circuit board's routing wire. Otherwise, the actual voltage at the Vin pin may exceed the absolute maximum rating. The output capacitor also must be located a distance of not more than 1cm from output to a clean analog ground. Because it can filter out the output spike caused by the surge current due to the inductive effect of the package pin and the printed circuit board's routing wire.

Package Outline

SOT-23

Dimensions in mm

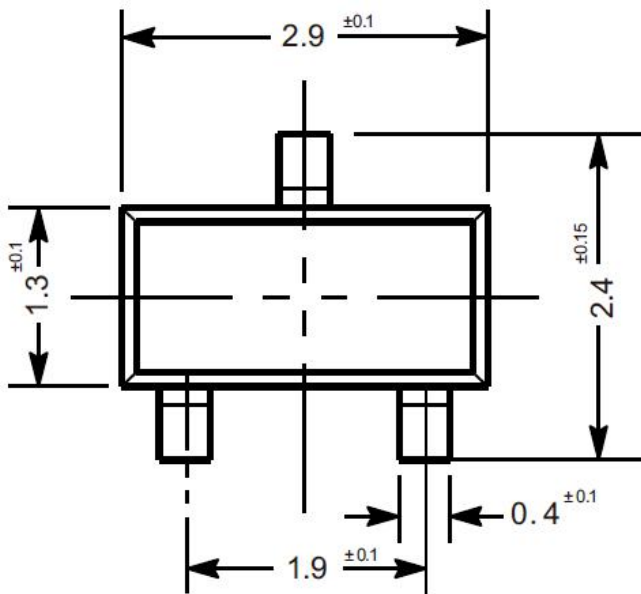

SEE VIEW

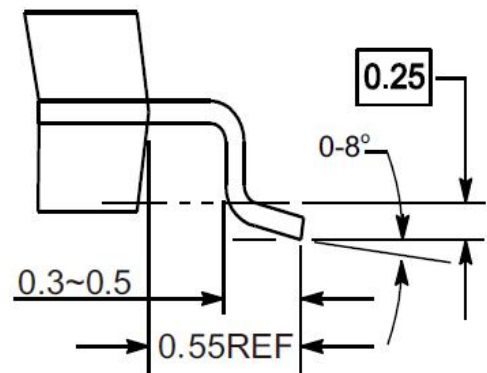
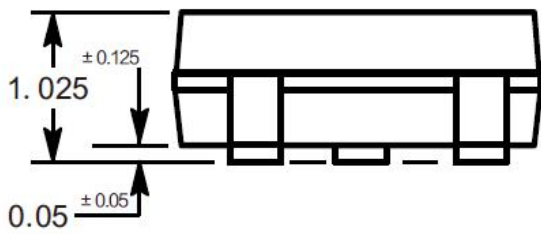
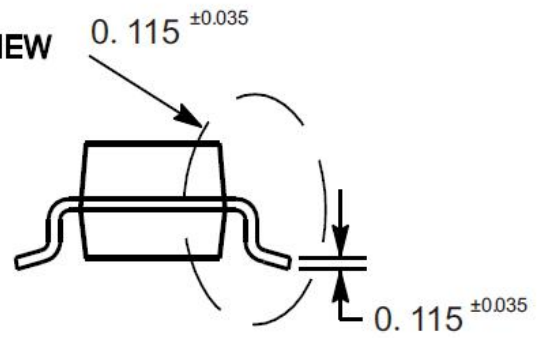

VIEW C

Package Outline

SOT-89

Dimensions in mm

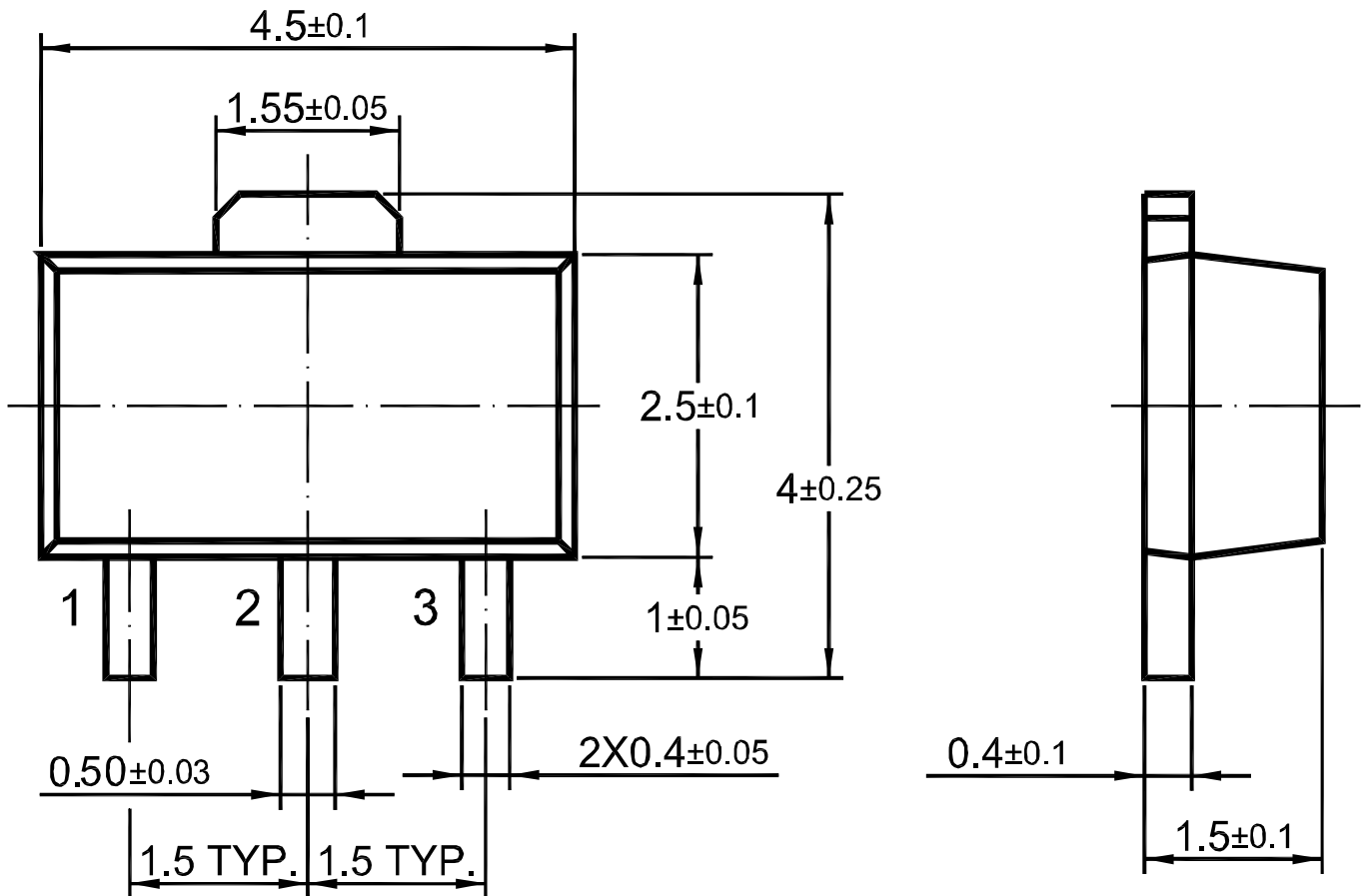

Package Outline

SOT-89-5

Dimensions in mm

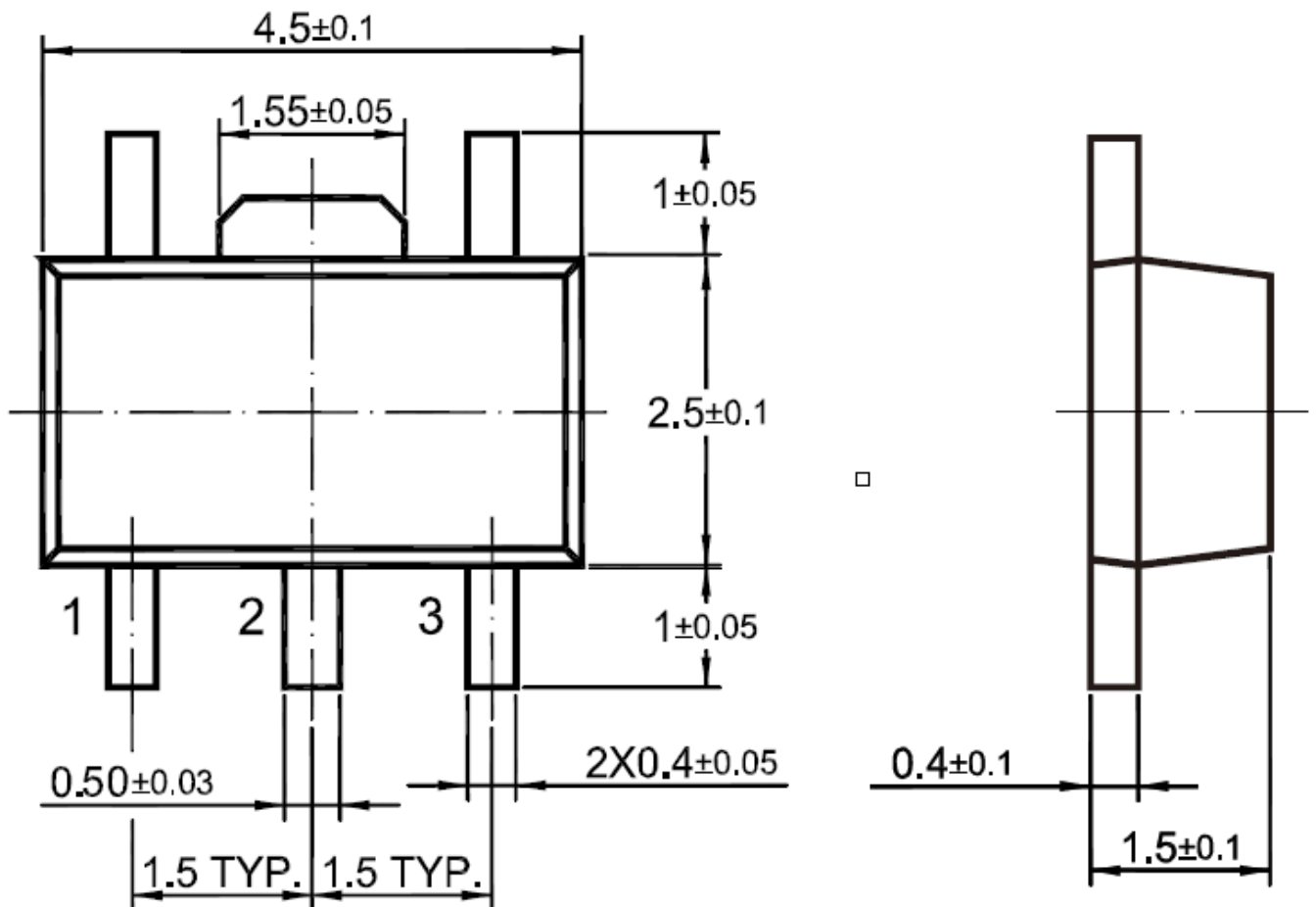

Package Outline

SOT-23-3

Dimensions in mm

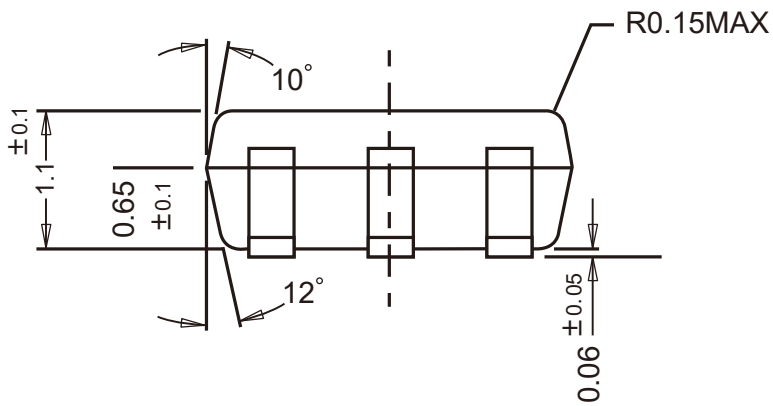
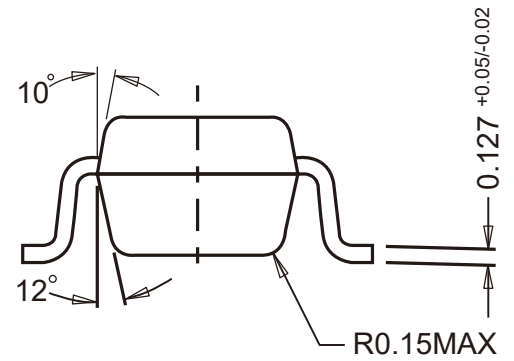
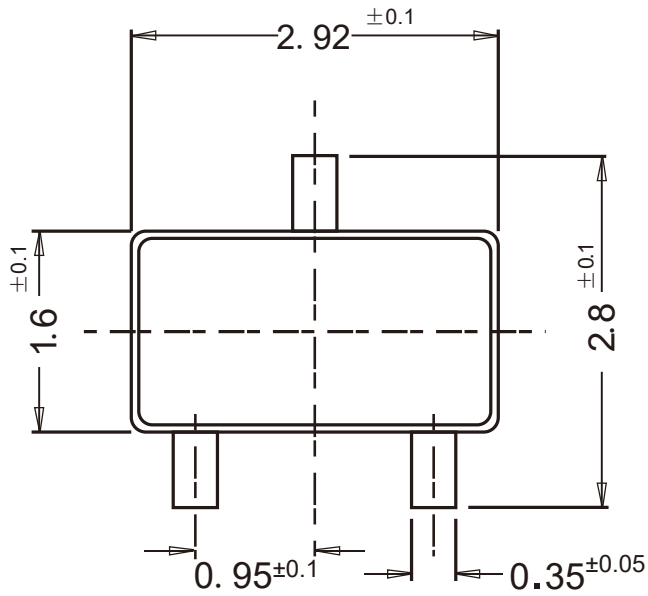

Package Outline

SOT-23-5

Dimensions in mm

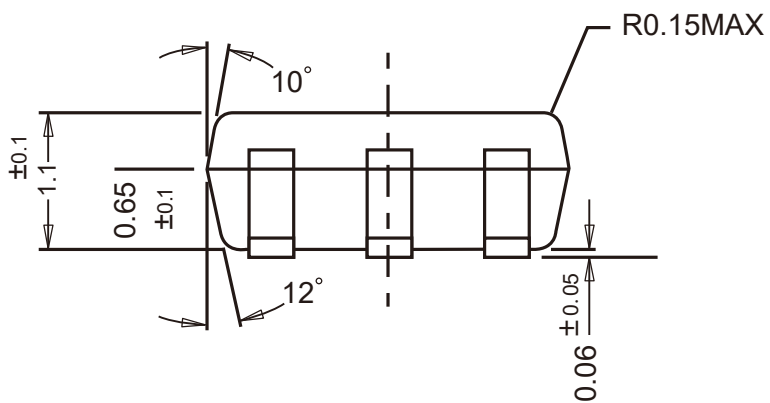
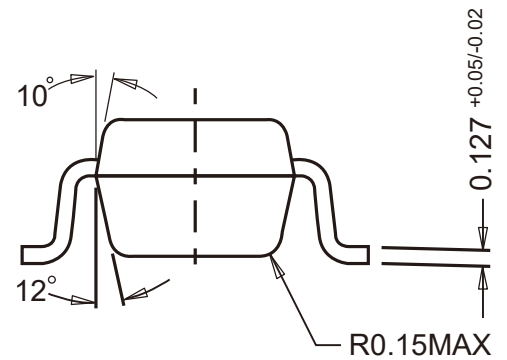
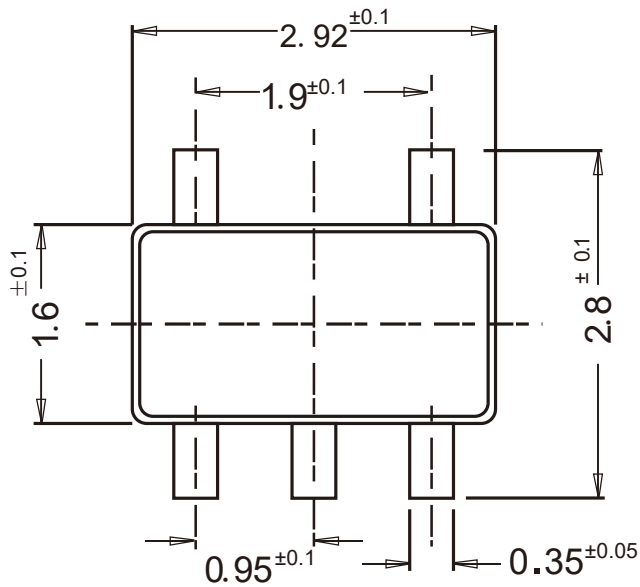

Package Outline

DFN1x1-4L

Dimensions in mm

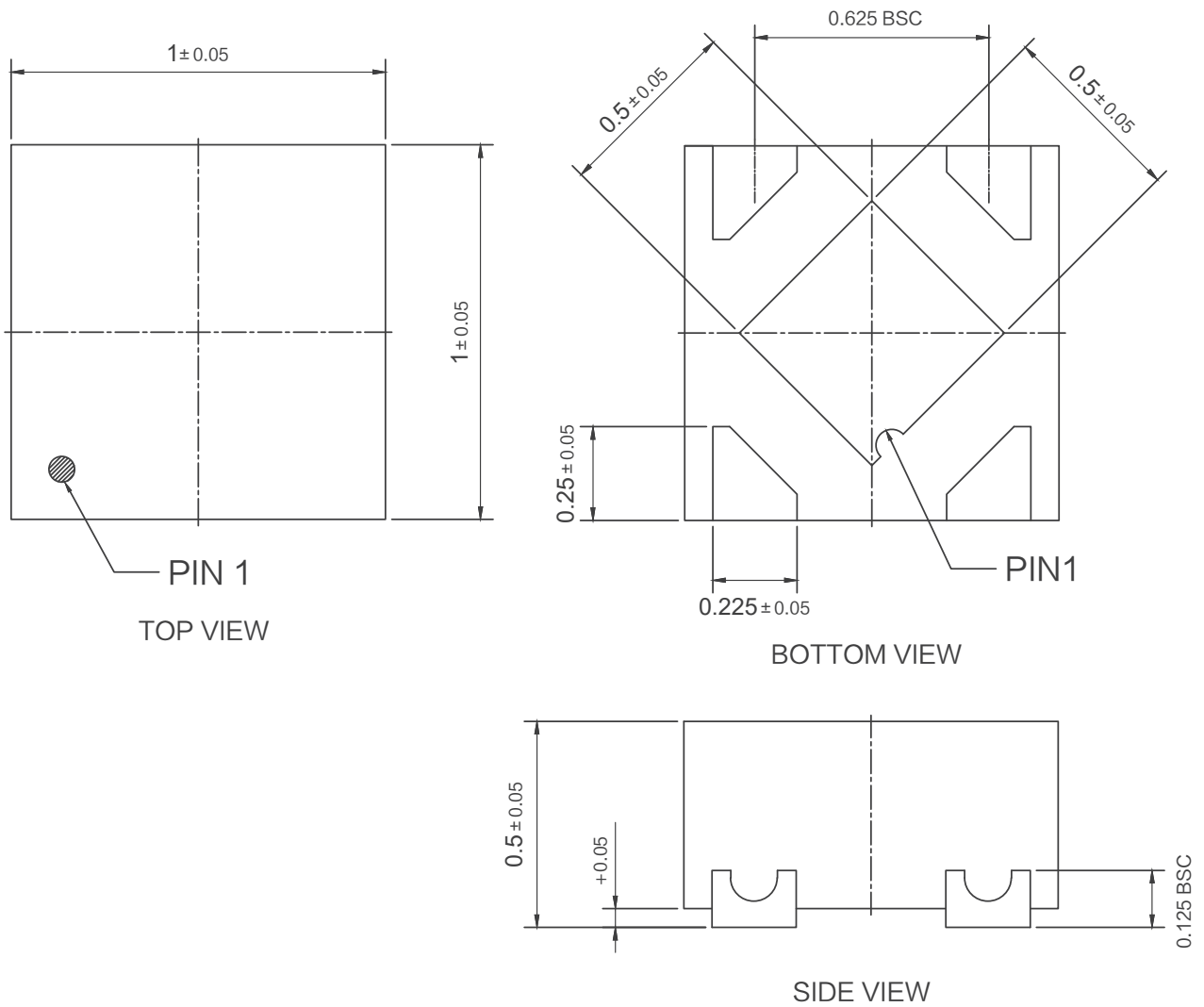

Package Outline

DFN2x2-6L-0006

Dimensions in mm

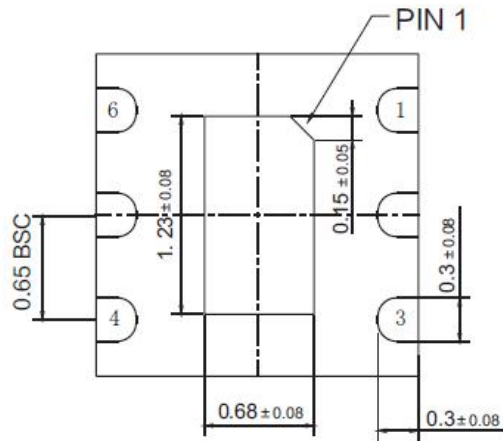

BOTTOM VIEW

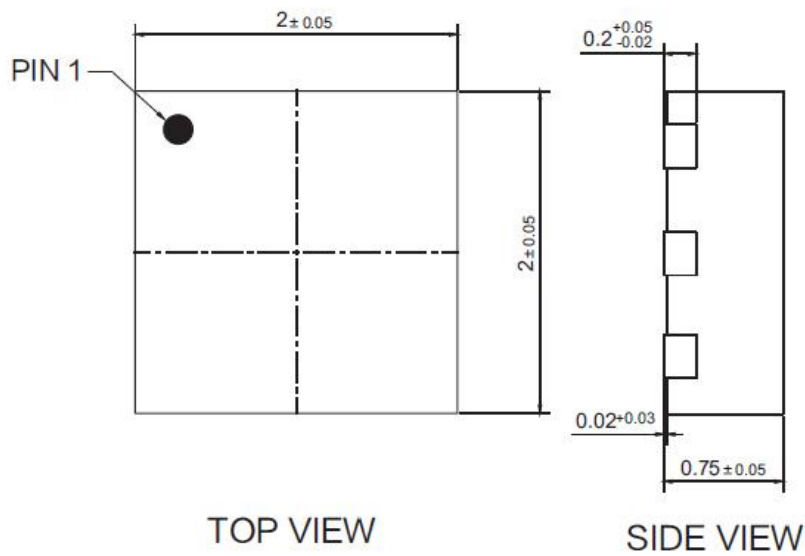

TOP VIEW

SIDE VIEW

X-ON Electronics

Largest Supplier of Electrical and Electronic Components

Click to view similar products for [Linear Voltage Regulators](#) category:

Click to view products by [SLKORMICRO](#) manufacturer:

Other Similar products are found below :

[LV5684PVD-XH](#) [MCDTSA6-2R](#) [L7815ACV-DG](#) [714954EB](#) [ZMR500QFTA](#) [BA033LBSG2-TR](#) [LV5680P-E](#) [L79M05T-E](#) [L78LR05D-MA-E](#) [NCV317MBTG](#) [NTE7227](#) [MP2018GZD-33-P](#) [MP2018GZD-5-P](#) [LV5680NPVC-XH](#) [LT1054CN8](#) [ZTS6538SE](#) [UA78L09CLP](#) [UA78L09CLPR](#) [CAT6221-PPTD-GT3](#) [MC78M09CDTRK](#) [NCV51190MNTAG](#) [78M05](#) [HT7150-1](#) [UM1540DB-18](#) [XC6234H281VR-G](#) [WL2834CA-6/TR](#) [TPL730F33-5TR](#) [TLS850F1TA](#) [V50](#) [TPS549B22RVFR](#) [UM1540DB-33](#) [WL9200P3-50B](#) [WL9100P3-33B](#) [WL9005D4-33](#) [XC6219B152MR](#) [WL2855K33-3/TR](#) [PJ54BM33SE](#) [PJ9500M25SA](#) [MD7218E33PC1](#) [H7533-2PR](#) [SK7812AU](#) [SD1A30](#) [78L33](#) [TP78L33T3](#) [L78L33ACUTR](#) [SK6513ST3A-50](#) [SK6054D4-09](#) [SK6054D4-18](#) [SK6054D4-11](#) [SK6054D4-10](#) [LM79L12F](#)